

SERVICE MANUAL

AKAI TAPE RECORDER

MODEL

1700

AND

1710

TABLE OF CONTENTS

I	SPECIFICATIONS	1
II	HOW TO MEASURE DESIGNATED VALUES OF SPECIFICATIONS	2
III	LOCATION OF CONTROLS	3
IV	DISASSEMBLY OF TAPE TRANSPORT UNITS AND AMPLIFIERS.....	4
V	TRANSPORT MECHANISM	6
VI	ADJUSTMENT OF TAPE TRANSPORT UNIT	9
VII	ADJUSTMENT OF AMPLIFIER	10
VIII	MAINTENANCE PROCEDURES	11
IX	LIST OF REPLACEMENT PARTS	12
X	EXPLODED VIEW OF COMPONENT PARTS	14
XI	TROUBLE SHOOTING CHART	21
XII	SCHEMATIC DIAGRAM	25
XIII	CONNECTING DIAGRAM	26

I SPECIFICATIONS

MODEL

NUMBER: Akai Model 1700, portable 4-track stereo tape recorder.

WEIGHT (NET

IN CARTON): 33 lbs (15 kg) without accessories.

DIMENSIONS : 13-1/2" (H) x 13-1/2" (W) x 9" (D) case closed.

POWER RE-

QUIREMENTS: A. C. 100, 110, 120, 200, 220 or 240 volts interchangeable. 50-60 cycles.

POWER CON-

SUMPTION: 80 VA.

RECORDING

SYSTEM: Inline 4 track stereo and 4-track monaural recording.

PLAYBACK

SYSTEM: Inline 4-track stereo, monaural playback.

TAPE SPEED : Three speeds; 7-1/2" (19 cm), 3-3/4" (9.5 cm) and 1-7/8" (4.75 cm) per second. (15" per second with an optional accessory capstan and pinch wheel.)

TAPE SPEED

DEVIATION: Less than ± 3 per cent at all tape speeds.

WOW AND

FLUTTER: Less than 0.2% at 7-1/2 ips. R.M.S.
Less than 0.3% at 3-3/4 ips. R.M.S.
Less than 0.45% at 1-7/8 ips. R.M.S.

FAST FORWARD AND REWIND

TIME: 150 seconds for 1,200 ft. tape at 50 cycles and 120 seconds at 60 cycles.

FREQUENCY

RESPONSE: 40 to 18,000 cps. at 7-1/2 ips;
 ± 3 db. 80 to 12,000 cps. at 7-1/2 ips;
 ± 3 db. 80 to 10,000 cps. at 3-3/4 ips;
 ± 4 db. 80 to 4,000 cps. at 1-7/8 ips.

DISTORTION : Within 4% at 1,000 cps, 0 VU (total harmonic)

SIGNAL-TO-

NOISE RATIO: 40 db below recorded level signal at all speeds.

CROSS TALK : Within 55 db between each track.

CHANNEL

SEPARATION: Better than 80 db at 1,000 cps +3 VU.

POWER INPUT

LEVELS: Microphone input level
-55 db (VR. max.) at 1,000 cps.
Phono and radio input level
-40 db (VR. max.) at 1,000 cps.

POWER

OUTPUT: Pre-Amplifier output, 0.7 V at 1,000 cps, impedance more than 100 K ohms.
Main output, 34 dbm. up (in 600 ohms).

INSULATION

RESISTANCE: More than 50 MEG ohms.

INSULATION

YIELD

STRENGTH: More than one minute at A.C. 1,000 V.

MONITORING

SYSTEM: With headphone during recording.

MOTOR

: Condenser starting induction two-speed motor.
1/100 HP. Power factor, 70 per cent.
2,900 to 1,450 r.p.m. at 50 cps,
3,480 to 1,740 r.p.m. at 60 cps.

HEADS

: Inline 4-track stereo/monaural record-play head;
Impedance... 3,500 ohms $\pm 10\%$ at 1,000 cps.
4-track erase head;
Impedance... 4,000 ohms $\pm 15\%$ at 90 kc.

MICROPHONE

USED: Round dynamic microphone
Impedance... 50,000 ohms
Sensitivity... -55 db.
Frequency Response... 70 to 15,000 cps ± 10 db.

SPEAKER

INCLUDED: Two 5" x 7" dynamic speakers.
Impedance... 8 ohms
Allowable Input... 6 watts
Frequency Response... 80 to 12,000 cps, ± 10 db.

TUBES USED : 12AT7 x 2, 6BM8 x 2.

SILICON

DIODE USED: 150D x 2

REELS USED : Up to 7" reel

RECORDING

LEVEL

INDICATOR: Horizontal, A-model VU meter.

II HOW TO MEASURE DESIGNATED VALUES OF SPECIFICATIONS

TAPE SPEED

DEVIATION: Record the 1,000 cps. sine curve of the tape speed at rating speeds with a standard sound recorder (AMPEX 351A, for instance) which is little affected by the tape speed deviation throughout the whole length of the tape. Put this standard tape on the tape recorder under test for playing back, and measure its output by a counter, then convert the value into rating power frequency to evaluate the tape speed deviation.

For a rough measurement, the tape speed deviation can also be measured with a testing tape for speed by a stop watch.

WOW AND

FLUTTER: Playback the 3,000 cps. standard tape that guarantees wow and flutter within 0.07 per cent, and read the effective value on wow meter.

Since the sensibility of wow and flutter frequency below 2 cps. and above 5 cps. drops, the frequency over 5 cps. is put to 3 db/OCT circuit, and the frequency below 2 cps. is put to 6 db/OCT circuit for adjustment. This adjusted value is called auditory compensated value.

FREQUENCY

RESPONSE: Connect to the input terminal of the recorder, record a sine curve sweep (OVERALL FREQUENCY RESPONSE) frequency at 100 cps -10 db, from Audio Frequency Oscillator.

Adjust tone volume to flat, playback the tape by connecting VTVM to speaker out put then read the frequency response to adjust a maximum deviation of 6 db.

TOTAL HARMONIC DISTORTION

FACTOR: Provide the input terminal of the recorder with 1,000 cps. sine curve signals and record these signals on a recording tape at the zero level on the recorder's VU meter.

Then playback the signals under the normal recording condition to measure the distortion factor by an oscillator. Remove the recording tape from the recorder, then read the noise level on the oscillator to get the required distortion factor by the following formula:

$$d0 = d - d1 - d2$$

d0...required

d...overall distortion factor

d1...noise level

d2...distortion factor of the oscillator used

SIGNAL TO

NOISE: Playback the sine curve, 250 cps. tape recorded on a standard recorder on the recorder to measure the voltage. Remove the tape, then measure the noise level under the same condition. Calculate the ratio between the two in decibel.

OUTPUT:

Playback on the recorder the 1,000 cps. sine curve tape which was recorded at the zero VU level on a standard recorder. Terminate the test recorder with eight ohms.

Square the voltage reading, then divide the figure by eight ohms to get the r.m.s. power output.

CROSS TALK:

Record 1,000 cps. signal at +3 VU on the third track, then playback this signal through a 1,000 cps. Band Pass Filter.

Compare the output of tracks 1 and 3 in decibels.

III LOCATION OF CONTROLS

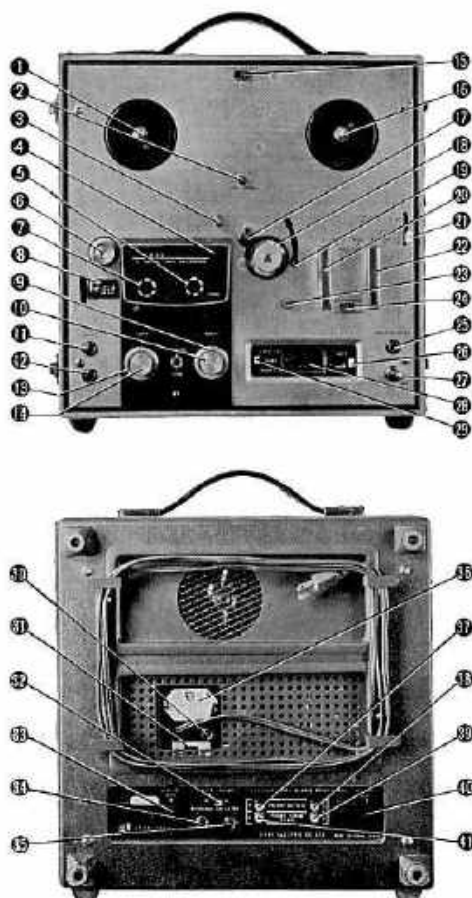

- | | |
|---------------------------------------|-----------------------------------|
| ① Supply reel shaft | ②② Rewind/Fast-forward switch |
| ② Cycle conversion switch | ②③ Record safety button |
| ③ Capstan storage post | ②④ Automatic stop switch |
| ④ Head cover | ②⑤ Stereo headphone jack |
| ⑤ Record/Play head | ②⑥ VU meter conversion switch |
| ⑥ Tape guide | ②⑦ Power switch |
| ⑦ Erase head | ②⑧ VU meter |
| ⑧ Index counter | ②⑨ Track selector switch |
| ⑨ Right channel volume control | ③⑩ Fuse post |
| ⑩ Right channel tone control | ③① Cycle conversion switch |
| ⑪ Left channel microphone input jack | ③② Speaker switch |
| ⑫ Right channel microphone input jack | ③③ Hum adjust (right) |
| ⑬ Left channel volume control | ③④ Speaker output jack (right) |
| ⑭ Left channel tone control | ③⑤ Speaker output jack (left) |
| ⑮ Speed change switch | ③⑥ Voltage selector switch |
| ⑯ Take-up reel shaft | ③⑦ Preamp output jack (right) |
| ⑰ Capstan shaft | ③⑧ Preamp output jack (left) |
| ⑱ Pinch wheel | ③⑨ Phono/Radio input jack (left) |
| ⑲ Automatic stop lever | ④⑩ Hum adjust (left) |
| ⑳ Record/Play switch | ④⑪ Phono/Radio input jack (right) |
| ㉑ Instant stop lever | |

IV DISASSEMBLY OF TAPE TRANSPORT UNITS & AMPLIFIERS

- (1) Loosen the RETAINING SCREW (a) of PINCH ROLLER (b) using a phillips-headed screw driver to remove the PINCH ROLLER (b).

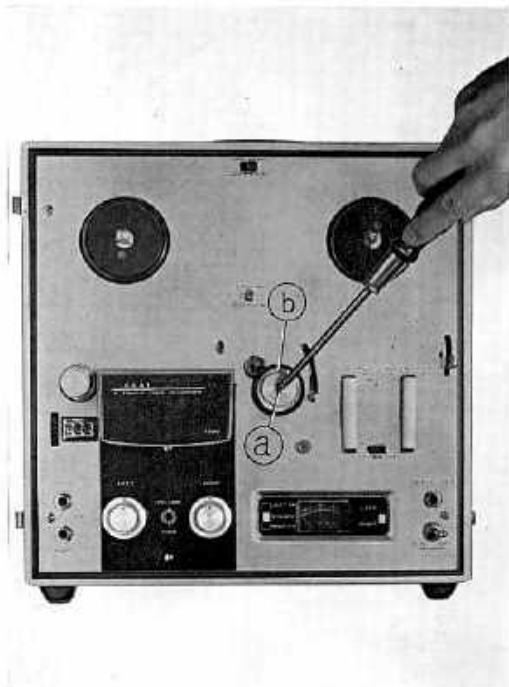

- (3) Loosen the SCREWS marked from (a) to (d) in order to remove DECK PANEL (P).

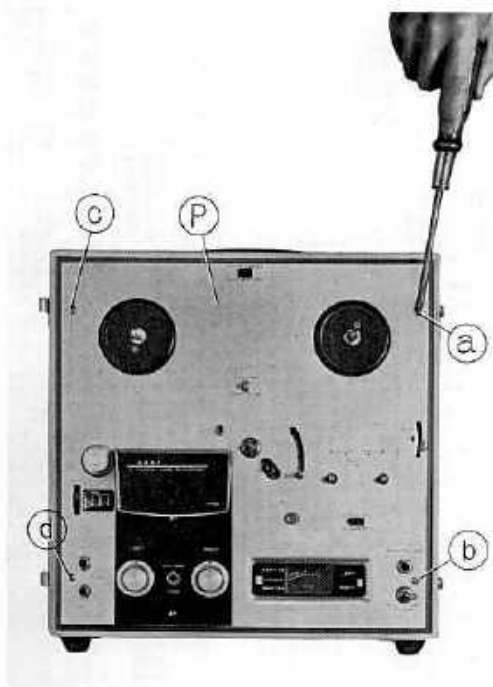

- (2) Remove the DECK CONTROL KNOBS (a) and (b) by loosening their retaining screws using a phillips-headed screw driver.



- (4) Loosen the SCREWS marked from (a) to (d).

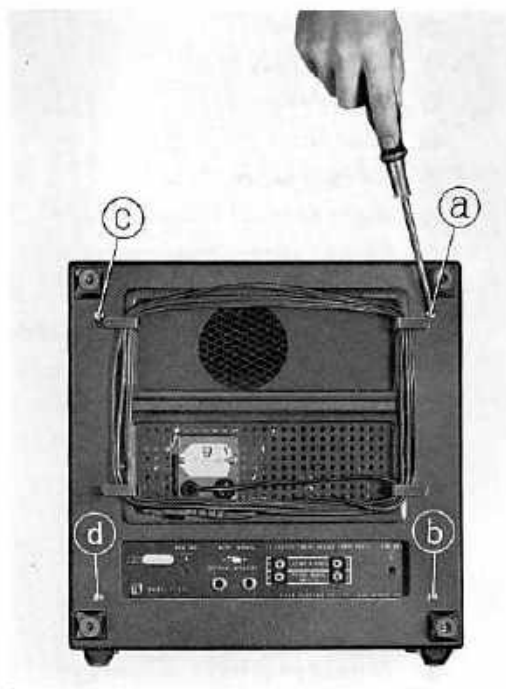

(5) Loosen the SCREWS marked from (a) to (d).

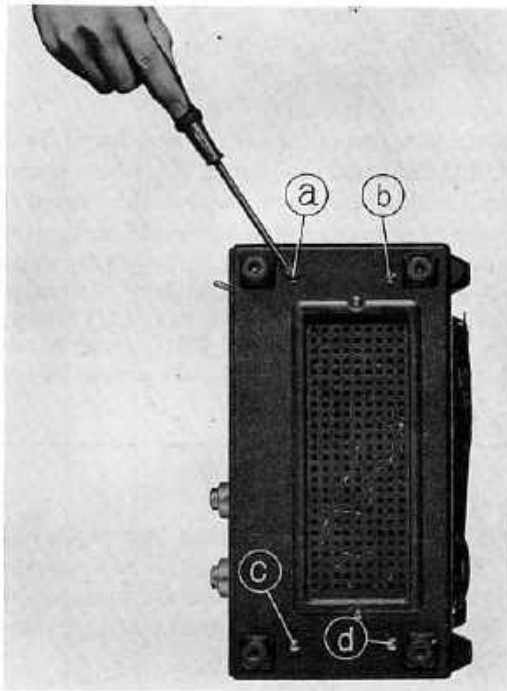

(6) Lift TAPE DECK and AMPLIFIER (D) from the cabinet (B).

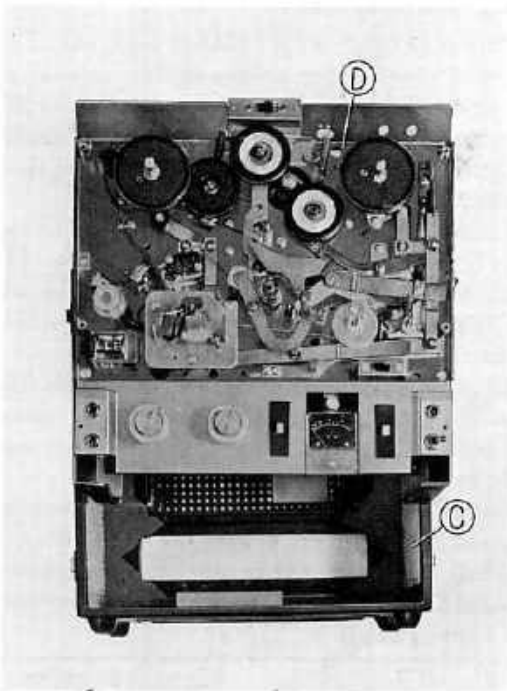

(7) Disconnect the PINS of speaker marked (a) and (d), the PLUGS of motor marked (e) and (f) and the PINS of head marked (g) and (j).

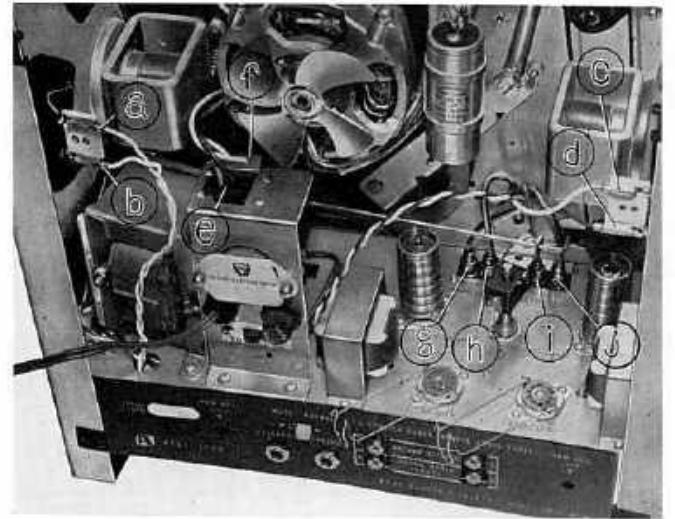

(8) Loosen the RETAINING SCREWS of deck frame marked from (a) to (d)

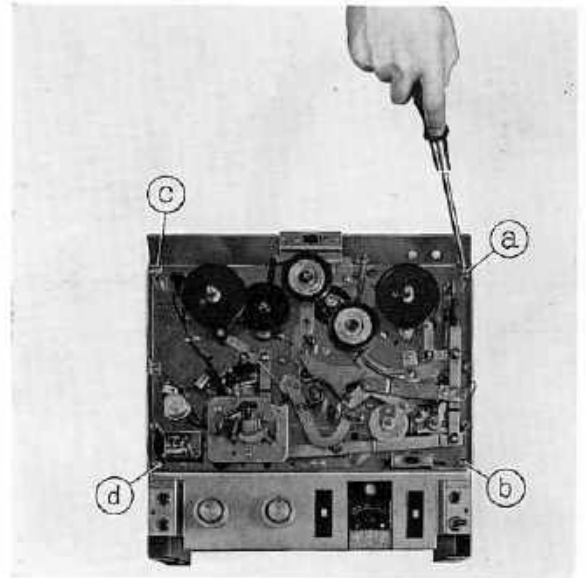

(9) Separate TAPE DECK (M) from AMPLIFIER (A).

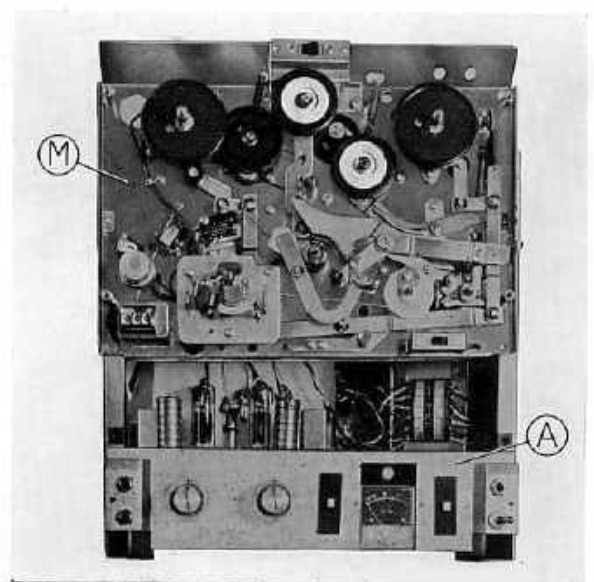

V TRANSPORT MECHANISM

Driving of Capstan

Figure 1.

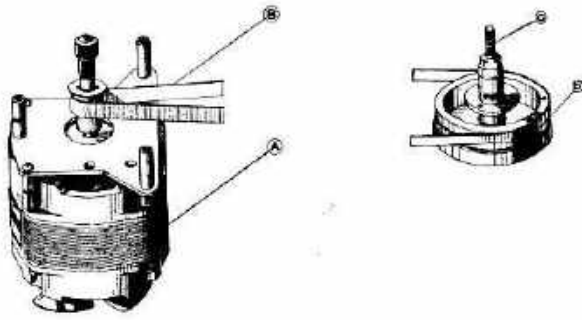

Fig. 1

- (A) Motor
- (B) Driving Belt (flat belt)
- (C) Capstan
- (D) Flywheel

High-speed rotation of *Motor* (A) is reduced by *Driving Belt* (B) and transmitted to *Capstan* (C), which is connected to *Flywheel* with ample inertia and enables rated rotation by absorbing minor rotation distortion of motor itself.

Capstan Rotation	606 r.p.m. at 7- $\frac{1}{2}$ " (19 cm) per sec.
	303 r.p.m. at 3- $\frac{3}{4}$ " (9.5 cm) per sec.
	151.5 r.p.m. at 1- $\frac{7}{8}$ " (4.75 cm) per sec.
Motor Rotation	2,900 to 1,450 r.p.m. at 50 cps.
	3,480 to 1,740 r.p.m. at 60 cps.

Driving of Pinch Roller

Put tape between rotating capstan and pinch roller and push pinch roller against capstan, this will transport the tape at rated speed. The appropriate pressure of pinch roller is between 1,000 to 1,150 grams at the tape speed of 7- $\frac{1}{2}$ " (19 cm) per second.

Recording and Play Back

Turn the *RECORD, PLAYBACK* knob (A) to "PLAY" position, and pinch roller presses against capstan to move tape at the rated speed. At the same time, *Idler* (B) moves between *Motor Bushing* (C) and the *Take-Up Reel Spindle* (D) to transmit the motor rotation to (D) so that the tape is moved and wound on the take-up reel.

The *Take-Up Reel Spindle Base* is made up of two plastic rollers (1 and 2) with a clutch felt in between. The *Idler* is rotating the plastic roller (2) under. Therefore, the tape-winding friction is adjusted by the slipping of the felt to enable rated winding of the tape.

On the other hand, the *Supply Reel Spindle* (H) has a *Brake roller* (E) hung on the Plastic Roller (4) under which provides appropriate back tension by the clutch felt slipping to the rotation of the *Pulley* (3) above.

To prevent accidental erasure, the *Record Interlock Button* (F) must be depressed before the *RECORD, PLAYBACK* knob can be moved to the "REC" position. The *Safety device* (G) is depressed to enter the record mode.

(See Figures 2 and 3)

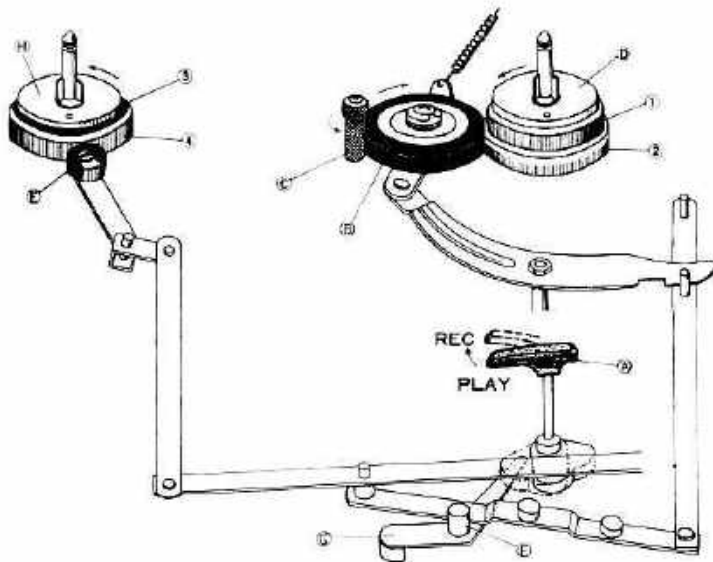

Fig. 2

Braked Rotation Slipping Rotation

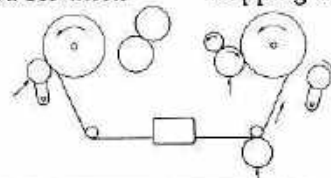

Fig. 3

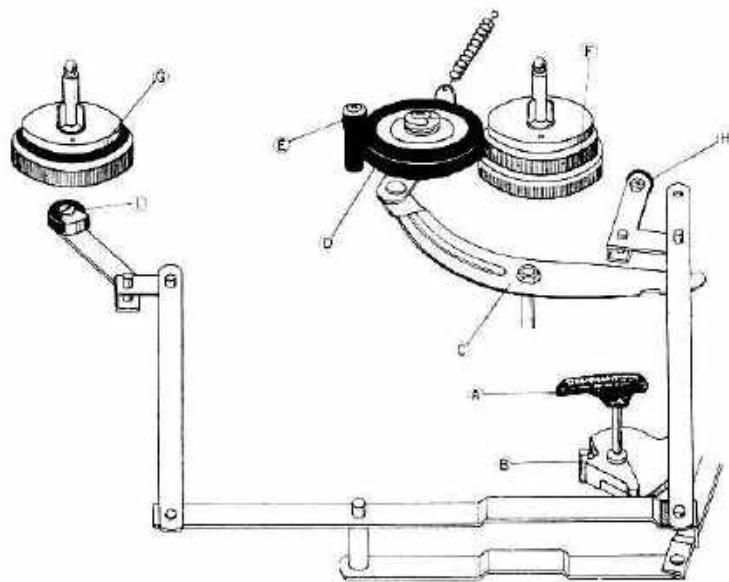

Fig. 4

FAST-FORWARD MECHANISM

Turn the *FAST FWD-REWIND knob (A)* to "FAST FWD" position, and the *cam (B)* under the knob pushes up the *Lever (C)*. The *Idler (D)* moves into the space between the *Plastic Roller (F)* above the *Take-Up Reel Spindle* and the upper part of the rotating motor drive bushing to transmit the motor rotation to the take-up reel spindle. At the same time, *Brake Rollers (H)* and *(I)* come off the reel spindle to free the *Supply Reel Spindle (G)*, thereby allowing fast winding of the tape onto the take-up reel.

(See Figures 4 and 5)

Free Rotation High-Speed Rotation

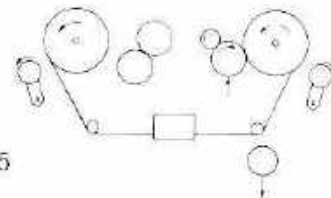

Fig. 5

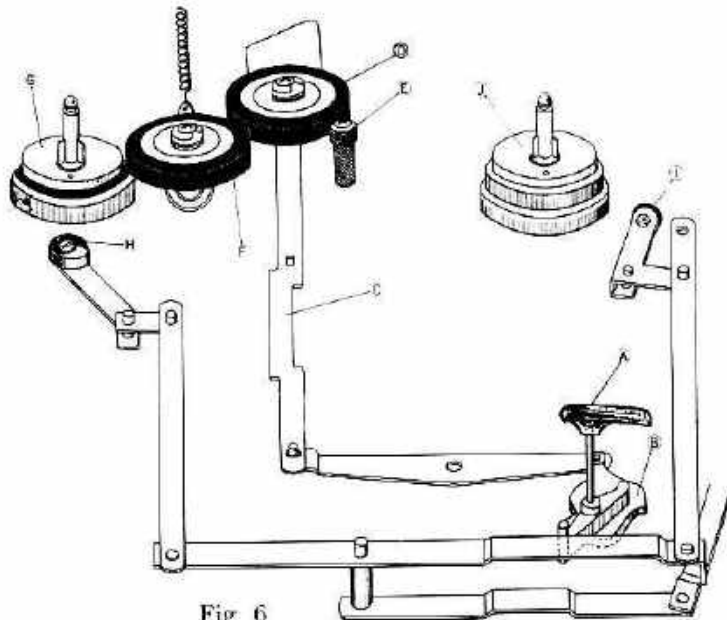

Fig. 6

REWIND MECHANISM

Turn the *FAST FWD-REWIND knob (A)* to "REWIND" position, and the *cam (B)* under the knob pushes the *Lever (C)* up. The *Idler (D)* moves into the space between the upper part of the rotating *Motor drive bushing (E)* and the *Intermediate Pulley (F)* to transmit the high-speed rotation of the motor through the intermediate pulley to the *Supply Reel Spindle (G)*. At the same time, *Brake Rollers (H)* and *(I)* come off the reel spindle to free the *take-up reel spindle (J)*, thereby rewinding the tape into the supply reel at a fast speed.

(See Figures 6 and 7)

High-Speed Rotation Free Rotation

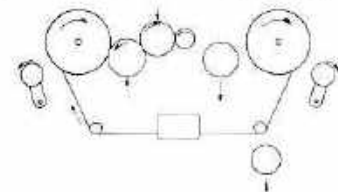

Fig. 7

STOP CONTROL

Push the stop lever to "STOP" position, *Brake Rollers (A)* and *(B)* depress reel spindles to stop rotation of the reel spindles.

As the brake rubber depresses the plastic rollers under the reel spindles, no friction works on the tape itself.

Modes of Operation	Pinch Roller	Take-up Idler Wheel	Rewind Idler Wheel	Take-up-side Brake	Supply-side Brake
(a) STOP	×	×	×	○	○
(b) FAST-FORWARD	×	○	×	×	×
(c) REWIND	×	×	○	×	○
(d) RECORDING PLAYBACK	○	○	×	×	×

NOTES: ×-marks indicates "open" and ○-marks "engaged"

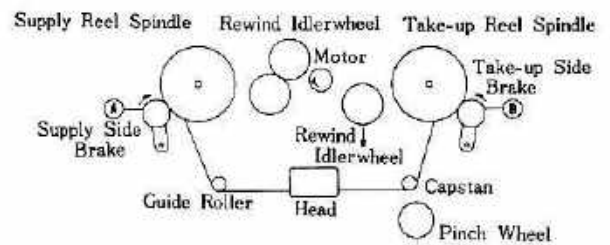

Fig. 8

RECORD/PLAYBACK CHANGING MECHANISM

By turning the RECORD/PLAYBACK KNOB (N) to the recording position, the LEVER (a) pulls the RECORDING LEVER (b) and (c), as illustrated in dotted line, then the RECORD/PLAYBACK CHANGE SWITCH (SW1) turns to recording position.

If the LEVER (c) does not turn properly, SW1 does not operate properly so may occur the abnormal oscillation and also can't record.

Then must adjust the LEVER (c) to proper position by loosening the SCREW (d).

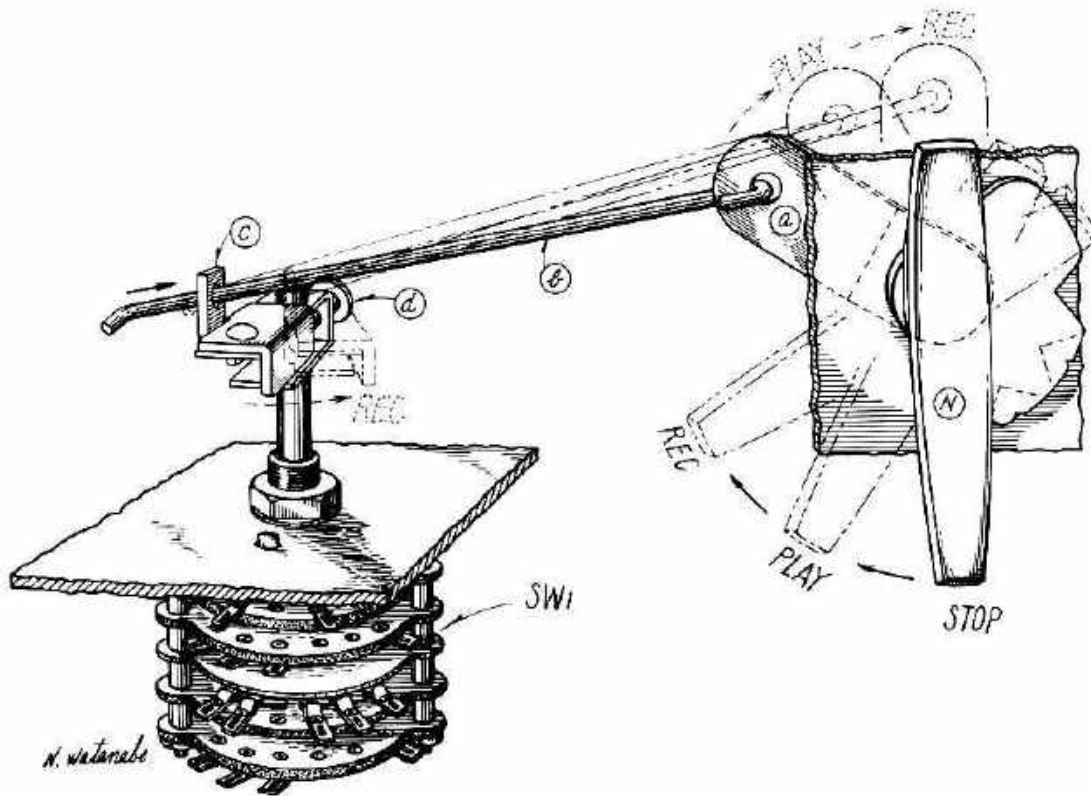

V ADJUSTMENT OF TAPE TRANSPORT UNIT

1. ADJUSTMENT OF PINCH WHEEL

It is important that the pinch wheel shaft is kept in complete alignment with the capstan shaft. A proper pinch wheel pressure is between 1,000 and 1,150 grams when the unit is operated at the tape speed of 7-½ ips. Any deviation from this specification will result in wow and flutter. Check pinch wheel pressure by a spring scale and, if necessary, adjust the pinch wheel load spring.

2. ADJUSTMENT OF TAKE-UP IDLER WHEEL

The take-up idler wheel must be kept in complete alignment with the take-up reel shaft. When the unit is set in fast forward condition, the idler wheel will contact to the upper knurled wheel of the take-up reel shaft assembly, and it will contact to the lower knurled wheel during record or play mode. Adjust idler wheel load spring so that the idler wheel pressure is kept between 50 and 80 grams. The idler wheel rapidly wears if the pressure is excessive. The slippage occurs if the pressure is smaller than the specification.

3. ADJUSTMENT OF REWIND IDLER WHEEL

The rewind idler wheel must be kept in complete alignment with the rewind reel shaft. The amount of pressure to the knurled motor bushing should be maintained about 50 grams during rewind operation. Adjust both the idler load spring and rewind roller.

4. ADJUSTMENT OF INTERMEDIATE WHEEL

The intermediate wheel is located between the rewind idler wheel and the rubber ring which is used on the upper part of the supply reel shaft assembly. When the unit is set in rewind mode, it will contact to these parts simultaneously delivering torque of motor. An adequate pressure is 50 grams. Adjust the load spring of the intermediate wheel if the pressure is not sufficient.

5. ADJUSTMENT OF TAKE-UP REEL SHAFT ASSEMBLY

A felt clutch material is attached to the bottom side of the reel table base plate so that recording tape will not be stretched during fast forwarding operation due to excessive tension. To check the amount of friction of this part, place a 5-inch reel with recording tape wound by 60 m/m in diameter, and gently pull the end of tape upward using a spring scale. Adjust the conical spring so that the amount of tension at this part will be kept between 400 to 500 grams. Another felt clutch material is attached to the take-up drive wheel. It is to provide proper slipping operation during record or play mode. The procedure for checking friction of this part is same as the foregoing, and between 120 and 200 grams of friction will provide the best result. Adjust the star-shaped spring just under the take-up drive wheel. When the unit is set in rewind mode, the amount of friction of this part will greatly be reduced and will become 10 to 20 grams. Check to see whether this is satisfactory if not, readjust the star-shaped spring for Brake, and spring retainer washed accordingly. (See figure 11 (a) at left)

6. ADJUSTMENT OF SUPPLY REEL SHAFT ASSEMBLY

A felt clutch material is used between the lower side of the reel table base plate and the rewind rubber ring to protect recording tape from an excessive tension while re-winding operation. To check the amount of friction of this part, place onto the supply reel table a 5-inch reel with recording tape wound by 60m/m in diameter and gently pull the end of tape upward by a spring scale. Adjust the conical spring so that the amount of tension is kept between 400 and 500grams. Another felt clutch is attached to the rewind drive wheel to provide proper slipping operation during record or play mode. The procedure for checking friction of this part is same as the foregoing, and between 80 and 120 grams of friction will give the best result. When the unit is set in fast forward mode, the amount of friction will greatly be reduced and will become 10 to 20 grams.

Check to see whether this is proper, if not, readjust coil spring and spring retainer washer. (See figure 11 (b) at left)

7. ADJUSTMENT OF TAPE HEAD

A vertical azimuth alignment of tape head is the only adjustment that can be made at the field of service. To align tape head, play 8,000 cycles recorded on an Ampex standard alignment tape. Rotate the azimuth alignment screw until a maximum playback level through the small hole which is positioned on the shield cover of the tape head assembly.

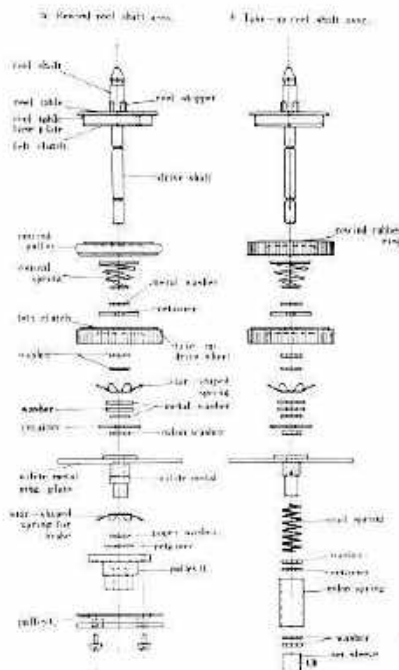

Fig. 11

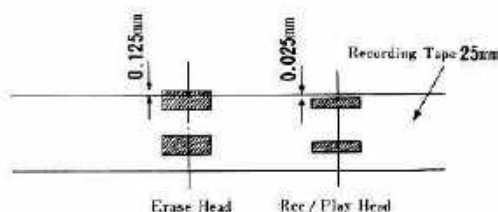

Fig. 12

VII ADJUSTMENT OF AMPLIFIER

1. ADJUSTMENT OF RECORDING BIAS FREQUENCY

Recording/erasing bias frequency was set at 90 KC plus or minus 5 KC before shipment. It is decided by inductance of the oscillator coil (part # 17-L₁) and its resonant capacitor (part # C-17). To measure recording bias frequency, insert a 10 or 100 ohm resistor in series to the record/play head and connect vertical input terminals of an oscilloscope as shown in the Fig. 13. Another testing instrument to be prepared is an audio frequency oscillator and its output should be connected to horizontal input terminals of the oscilloscope. Vary frequency generated by the audio frequency oscillator around 90 KC, and set the oscillator at the point where a desirous figure appears on the oscilloscope. The recording bias frequency now corresponds to the reading of the oscillator. Check oscillator coil, C-17 and bias head if the recording bias frequency measured is not within 90 KC \pm 5 KC.

2. ADJUSTMENT OF RECORDING BIAS VOLTAGE

A proper recording bias voltage is 45 volts \pm 3 volts A.C. and is adjusted by C16. To measure recording bias voltage, connect a V.T.V.M. (Vacuum Tube Volt Meter) to the record/play head as shown in the Fig. 14.

Check C16 (included AK 13) and record/play head if the recording bias voltage measured does not meet to the above-mentioned specification.

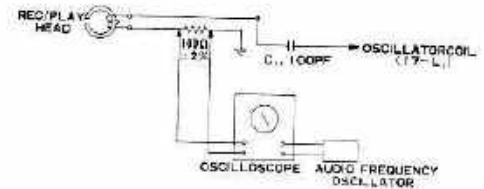

Fig. 13

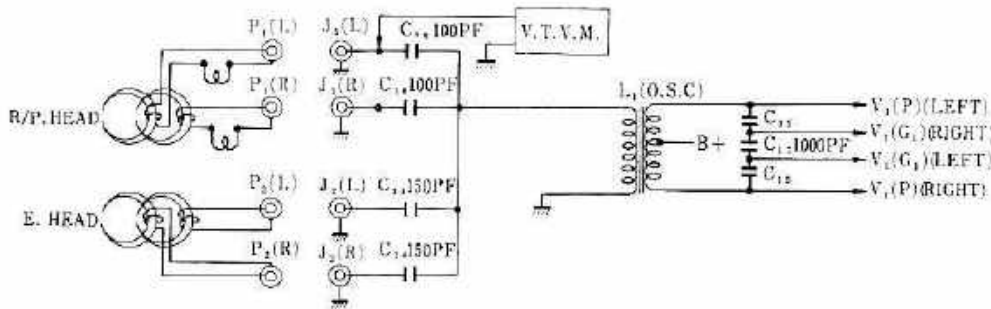

Fig. 14

3. ADJUSTMENT OF ERASING BIAS VOLTAGE

A proper erasing bias voltage is 65 volts \pm 5 volts A.C. and is adjusted by C14. To measure erasing bias voltage, connect a V.T.V.M. to the erase head as shown in the Fig. 15.

Check C14 and erase head if the erasing bias voltage measured does not meet to the above-mentioned specification.

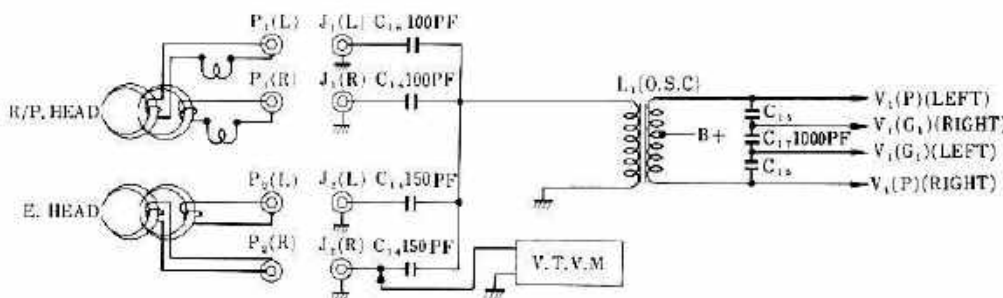

Fig. 15

4. ADJUSTMENT OF RECORDING LEVEL

A basic recording level, referred to as "0 VU", set at the point where current of 30 μ A \pm 10 % flows to the recording head at 1,000 cycles. The VU meter indicates 0 VU \pm 2 VU when a signal of -55 db \pm 5 db at the microphone jack or -40 db \pm 5 db at the line input jack when the volume control set at its maximum.

Adjustment of recording level can be accomplished by varying sensitivity of VU meter, however, it is not necessary to make in a field of service as all VU meters have correctly been calibrated at factory before shipment. (See Fig. 16 for details.)

NOTE: Make sure to stop oscillation by disconnecting the oscillator coil # 17-L₁ at the points marked "P" and "G" prior to measurement of recording level.

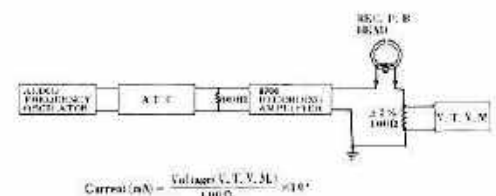

Fig. 16

VIII MAINTENANCE PROCEDURES

I. LUBRICATION INSTRUCTION

For maximum service life and optimum performance, lubricate the parts identified below after each 500 hours of operation. Use only light machine oil of good quality

Motor	3 drops
Drive Capstan Shaft	2 drops
Rewind Idler Wheel Bearing and Wind take-up Idler Bearing.	1 drop
Intermediate Idler Bearing	1 drop
Pinch Wheel Bearing	2 drops
Take-up and Supply Reel Shaft Bearing &	2 drops

Also apply a liberal film of light machine grease to each roller surface of all levers and cams.

CAUTION: DO NOT OVER-LUBRICATE. WIPE OFF EXCESS OIL BY A COTTON SWAB SOAKED IN ALCOHOL. OTHERWISE, THE OVER-FLOWED LUBRICANT MAY BE SCATTERED DURING OPERATION. THE RUBBER COMPONENT PARTS WILL BE DETERIORATED.

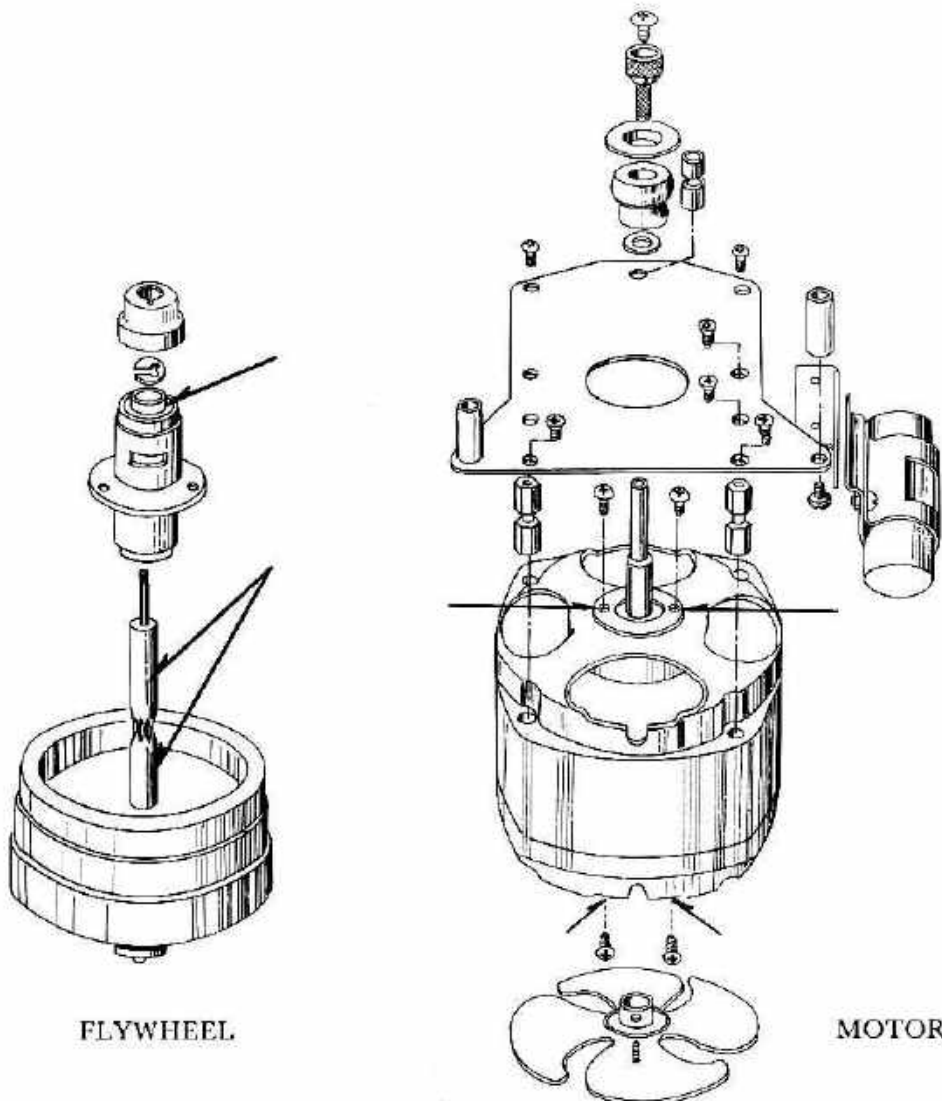

Fig. 17

2. CLEANING TAPE HEADS AND OTHER PARTS

Wipe surface of tape heads, guide roller bearing, capstan bushing and pinch wheel periodically with a soft cloth soaked in alcohol or carbon-tet.

IX LIST OF REPLACEMENT PARTS

Parts No.	Nomenclature
TOP PANEL	
171-001	Deck Panel
002	Head Cover
003	Frame, Head Cover
004	Capstan Rest
004a	Capstan Holder
005a	Table A, Tape Guide
005b	Washer
005c	Table, Washer
005d	Washer
005e	Bearing (635JZZ)
005f	Washer
005g	Table, Washer
005h	Washer
005i	Table B, Tape Guide
005j	Prop, Tape Guide
006	Plate
DECK FRAME	
172-001	Deck Frame
002	Head Assembly, Complete
002a	Erase Head
002b	Record/Playback Head
002c	Screw Flat Mould 4x8
002d	Prop A, Head
002e	Prop C, Head
002f	Screw Flat Mould 4x8
002g	Screw Flat 4x8
003	Index Counter, Complete
003a	Pulley, Counter
003b	Belt, Counter
003c	Screw, Without Head 4x7.5
004	Supply Reel Assembly
004a	Screw Flat 3x6
004b	Plate, Reel Table
004c	Reel Shaft A, Supply Reel
004d	Rubber Ring
004e	Rewind Pulley
004f	Spring G, Left
004g	Washer
004h	Washer Pin, Large
004i	Felt Washer
004j	Take-up Roller, C
004k	Holder, Reel Shaft (Star Type Spring)
004l	Washer
004m	Washer
004n	Washer
004o	Washer Pin, large
004p	Washer
004q	Metal Fitting A, Reel Table
004r	Holder, Reel Shaft (Star Type Spring)
004s	Washer

Parts No.	Nomenclature
172-001r	Washer Pin
004u	Pulley, Reel Shaft
004v	Screw, without Head
005	Take-up Reel Assembly
005a	Reel Shaft A, Take-up Reel
005b	Felt Washer
005c	Take-up Roller, A
005d	Spring G, Right
005e	Decor Skin
005f	Take-up Roller, B
005g	Holder, Reel Shaft (Star Type Spring)
005h	Metal Fitting B, Reel Table
005i	Spring, F3
005j	Washer
005k	Washer
005l	Washer Pin
005m	Nylon Spring
006a	AS Lever, Complete
006b	Plate, AS Lever, with AS Lever Prop
006c	Screw Bind 3x5
006d	Washer Pin
006e	3 mm Ground Lug
007a	Instant Stop Lever, A
007b	Spring, Instant Stop Lever
007c	Stopper, Instant Stop Lever
007d	Screw Bind 3x5
007e	Holder B, Instant Stop Lever
007f	Screw Flat Mould 4x8
008a	Recording Safety Button
008b	Cam Stopper
008c	Fiber, Cam Stopper
008d	Insulator Plate, Cam Stopper
008e	Screw Flat Mould 4x8
009a	Pinch Wheel
009b	Metal Cap, Pinch Wheel
009c	Screw
009d	Lever, Pinch Wheel
009e	Shaft C, Pinch Wheel
009f	4 mm Nut
009g	Shaft A, Cam Roller
009h	Cam Roller B
009i	Shaft, Pinch Wheel Lever
010a	Lever, Take-up Brake
010b	Take-up Brake Roller
010c	Screw, Brake Roller
010d	3 mm Nut
010e	Shaft, Take-up Brake Lever
010f	Washer Pin
011a	Lever, Supply Brake
011b	Supply Brake Roller
011c	Screw, Brake Roller
011d	3 mm Nut
011e	Shaft, Supply Brake Lever
011f	Washer Pin
012a	Switch, Automatic Shut-off (6P Slide Switch)

Parts No.	Nomenclature
172-012b	Plate, Automatic Shut-off Switch
012c	Screw Semi-Cubic 3x5
013a	Micro Switch M-B-3
013b	Holder, Switch
013c	Screw Semi-Cubic 3x5
013d	Screw Flat Mould 3x15
013e	Washer
014a	Switch, Speed Change (6P Slide Switch NC)
014b	Plate, Speed Change Switch
014c	Screw Flat Mould 4x10
014d	Cord Support
015a	Idler Wheel
015b	Washer
015c	Washer Pin
016a	Internal Wheel
016b	Washer
016c	Washer Pin
017a	Lever, A
017b	Shaft, Lever A
018a	Lever, B
018b	Cam Roller, A
018c	Cam Roller, B
018d	Washer Pin
019a	Lever, C3
019b	Washer Pin
019c	Washer
020	Lever, D
021	Lever, E-2
022a	Lever, FA
022b	Cam Roller, A
022c	Washer Pin
023a	Lever, G
023b	Holder, Lever G Metal
023c	Stopper, Lever G
023d	Lever G Metal
024a	Lever, H-C
024b	Idler Shaft, B
025a	Lever K
025b	Screw A
026a	Lever F, for Motor
026b	Fiber Washer
026c	Washer Pin
027	Prop, Panel
028	Spring Pin, B
029	Spring Holder
030a	Hum Bucking Coil, for Left Channel

Parts No.	Nomenclature
172.030b	Hum Bucking Coil, for Right Channel
030c	Holder, Hum Bucking Coil
030d	Screw Semi.Cubic 3×22
032a	Lever, Belt Change
032b	Metal Fitting, Belt Change Lever
032c	Spring, Belt Change Lever
033a	Table, Lifter Pin
033b	Lifter Pin
033c	Spork, for Lifter
033d	Cam A, Head Lifter
033e	Cam B, Head Lifter
034a	Spring A
034b	Spring, UN-D
034c	Spring, D
034d	Spring, E
034e	Spring, Idler
034f	New Spring D
034g	Torsion Spring
034h	Spring, B
034i	Spring, Belt Change
034j	Spring B, Belt Change
173.001	Motor, Complete
001a	Screw Flat Mould 3×15
001b	Stepped Pulley
001c	Belt Holder
001d	Motor Pulley
001e	Oil Retainer
001f	Motor Holder
001g	Motor
001h	Motor Fan, D
001i	MP Condenser 2uf (260VAC)
001j	Holder, Motor Condenser
001k	Prop, Motor 8×22.5
001l	Prop, Motor 8×21.5
001m	Screw
001n	Screw
001o	Screw Flat Mould 4×50
001p	Screw, without Head 4×5
001q	Screw Bind 3×5
001r	Hexagonal Nut
174.001	Flywheel, Complete
001a	Capstan
001b	Main Metal Case
001c	Flywheel
001d	4 mm Ball Bearing
001e	Plate C, Flywheel
001f	Washer
001g	Washer
001h	Wing Nut
001i	Screw, Flywheel adjust
001j	Prop B, Flywheel
001k	Prop C, Flywheel
001l	Drive Belt
175.001	Switch Block
001a	Knob, Record/Playback & Rewind Fast Forward
001b	Screw

Parts No.	Nomenclature
175.001e	Cam A
001d	Cam B
001e	8 mm Ball Bearing
001f	Switch Table, A
001g	Lever, I
001h	Fast/Forward Rewind Shaft
001i	RC/Playback Rewind Shaft
001j	Pin
001k	Plate, Cam
001l	Spring, K
001m	Cam, C
001n	Switch Table, B
001o	Record/Playback Conversion Pin
001p	Spork Cam
001q	Washer
001r	Prop
001s	Screw Bind 3×5
001t	Screw
001u	Screw
001v	Screw
001w	Nut
CASE	
176.001	Cabinet, Complete
002a	Table, Rubber Foot
002b	Rubber Foot
002c	Screw Semi-Cubic 3×18
003a	Ventilator (Panel Escutcheon)
003b	Screw Truss 6×12
004a	Ventilator, A
004b	Screw Truss 6×12
005a	Ventilator, B
005b	Screw Truss 6×12
006	Prop C, Reel
007	Russ. Plate, Speaker
008a	Chassis A, Speaker
008b	Chassis B, Speaker
009a	Speaker 5×7"
009b	Screw Flat Mould 4×12
010	Speed Nut
AMPLIFIER	
17-A1	Amp. Chassis
A2	1700 Name Plate
A3	Amplifier Knob, A (Tone)
A4	Amplifier Knob, B (Volume)
A5	Angle, changing Voltage
A6a	Screw, without Head 4×6.5
A6b	Screw, without Head 4×11.5
A6c	Screw, Semi.Cubic 4×8
17-AK13	C.R. Compound Body
AK14	C.R. Compound Body

Parts No.	Nomenclature
17.C2	Mica Condenser 101J 500 WV
C3	Ceramic Condenser 0.02 P 500 WV
C4	Ceramic Condenser 0.02 P 500 WV
C5	Oil Paper Condenser 0.05 M 400 WV
C6	Ceramic Condenser 0.02 P 500 WV
C7	Ceramic Condenser 0.01 P 500 WV
C8	Ceramic Condenser 0.02 P 500 WV
C9	Ceramic Condenser 0.02 P 500 WV
C10	Ceramic Condenser 0.002 P 1 KWV
C11	Ceramic Condenser 0.02 P 500 WV
C12	Tubular Type Electrolytic Condenser 50 µf 25 WV
C14	Mica Condenser 101J 500 WV
C16	Mica Condenser 151J 500 WV
C18	Mica Condenser 500J 500 WV
C20a-b	Lug Terminal Type Electrolytic Condenser 40+40 µf 350 WV
C21	Tubular Type Electrolytic Condenser 40 µf 350 WV
C22	Tubular Type Electrolytic Condenser 20 µf 300 WV
C23	Tubular Type Electrolytic Condenser 10 µf 15 WV
C24	Tubular Type Electrolytic Condenser 10 µf 10 WV
17-R1	Fixed Resistor 1/4 P 500 KΩ
R2	Fixed Resistor 1/4 P 3 KΩ
R3	Fixed Resistor 1/4 P 2.2 MΩ
R4	Fixed Resistor 1/2 P 250 KΩ
R5	Fixed Resistor 1/2 P 100 KΩ
R6	Fixed Resistor 1/4 P 2 KΩ
R7	Fixed Resistor 1/2 P 250 KΩ
R8	Fixed Resistor 1/4 P 500 KΩ
R9	Fixed Resistor 1/4 P 20 KΩ
R10	Fixed Resistor 1/4 P 1 MΩ
R11	Flexible Resistor 1 W 8 Ω
R12	Fixed Resistor 1/4 P 200 Ω
R13	Fixed Resistor 1/4 P 10 KΩ
R14	Fixed Resistor 1/4 P 500 KΩ
R15	Fixed Resistor 1/4 P 500 KΩ
R16	Fixed Resistor 1/4 P 1 KΩ
R18	Wired Resistor 10WL 470 Ω
R19	Wired Resistor 10WL 470 Ω
R20	Fixed Resistor 1L 10 KΩ
R21	Wired Resistor 3WL 180 Ω
R22	Flexible Wired Resistor 3W 8 Ω
R23	Fixed Resistor 1/4 P 10 KΩ
R24	Fixed Resistor 1/4 P 500 Ω
17.VR1.2	Variable Resistor 1 M(A) 50K(A) Double VR
VR3	Wired Variable Resistor 1/2 W 100 Ω
VR4	Wired Variable Resistor 1/2 W 100 Ω

Parts No.	Nomenclature
17.SD1	Silicone Diode SM-150D
SD2	Silicone Diode SM-150D
17.F1	Fuse Post
F2	Fuse, 2A
17.J1	2 Connective Pin Jack
J2	2 Connective Pin Jack
J3-5	2 Connective Pin Jack
J4	2 Pole E Jack
J6	2 Pole E Jack
J7	3 Pole E Jack
17.T1	Power Transformer
T2	Out-put Transformer
17.L1	Oscillator Coil
L2	Choke Transformer
17.M1	VU Meter
17.PL1	Pilot Lamp
PL2	Lamp Socket, Swan Type
17.SW1	Rotary Switch (Record/ Playback Conversion)

Parts No.	Nomenclature
17.SW2	6P Slide Switch, with White Knob (Meter Conversion)
SW3	6P Slide Switch, with White Knob (Speaker ON/OFF)
SW4	8P Slide Switch (Track Selector)
SW5	Toggle Switch (Power ON/OFF)
SW6	6P Slide Switch, with Black Knob (50/60 cycle change)
17.TB1	52L2 Lug Plate
TB2	42L1 Lug Plate
TB3	41L2 Lug Plate
TB4	31L1 Lug Plate
TB5	2L1 Lug Plate
17.V1a	Vacuum Tube 12AT7
V1b	Vacuum Tube 12AT7
V2a	Vacuum Tube 6BM8
V2b	Vacuum Tube 6BM8
17.VS1	Vacuum Tube Socket, 9P mould type
VS2	Vacuum Tube Socket, 9P mould type

Parts No.	Nomenclature
17.VS3	Vacuum Tube Socket, 9P mould type
VS4	Vacuum Tube Socket, 9P mould type
17.Z1	Transformer Angle, Left
Z2	Transformer Angle, Right
Z3	Name Plate, Cycle Change
Z4	Socket, change Voltage
Z5	Hexagonal Prop, Selector
Z6	Name Plate, change AC
Z7	3 mm Nut, special
Z8	Cord Support
Z9	Rubber Bush, AC Cord
Z10	AC Cord
Z11	Plate A, Jack
Z12	Plate B, Jack
Z13a	Clamp Pin, for 6BQ5
Z13b	Clamp Pin, for 12AT7
Z14a	Screw Semi-Cubic 4x8
Z14b	Screw Semi-Cubic 3x6
Z14c	Screw Flat Mould 4x16
Z14d	Screw Semi-Cubic 3x6

X EXPLODED VIEW OF COMPONENT PARTS

Front Panel

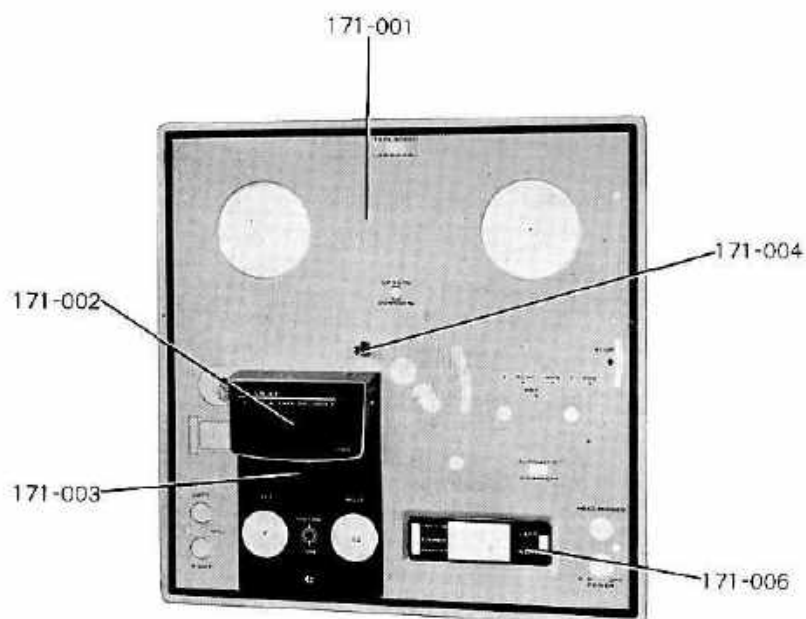

Amplifier I

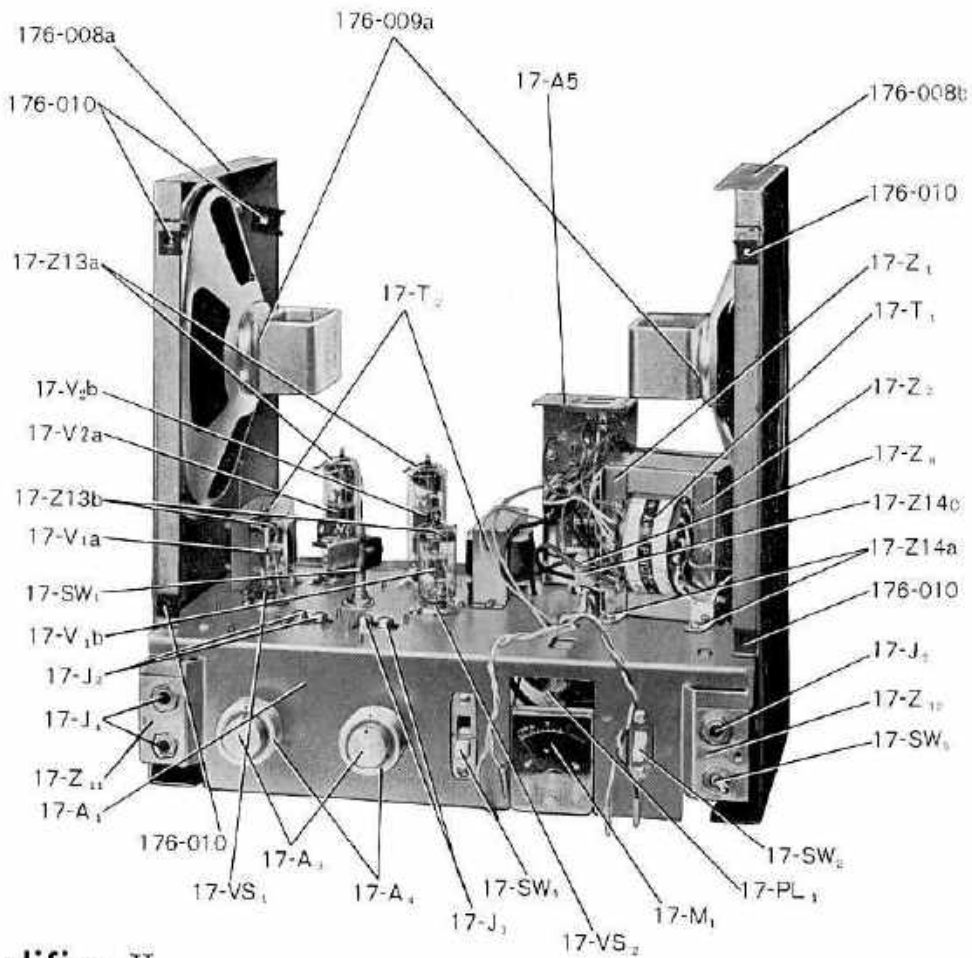

Amplifier II

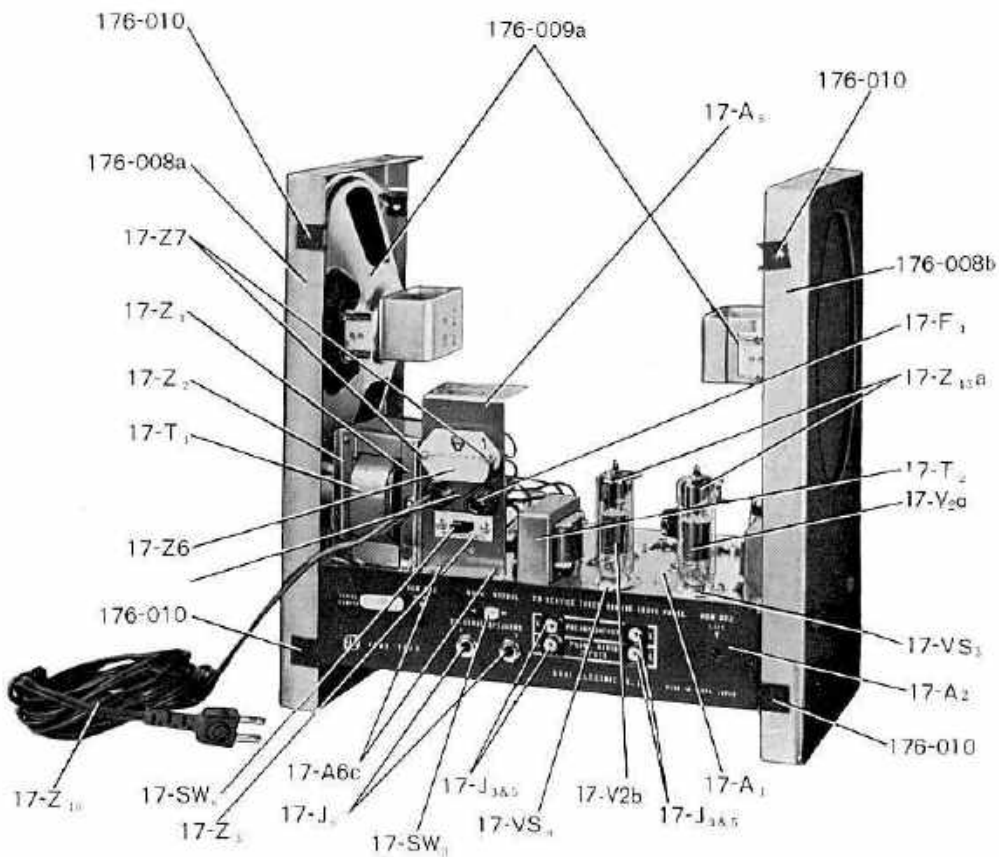

Amplifier III

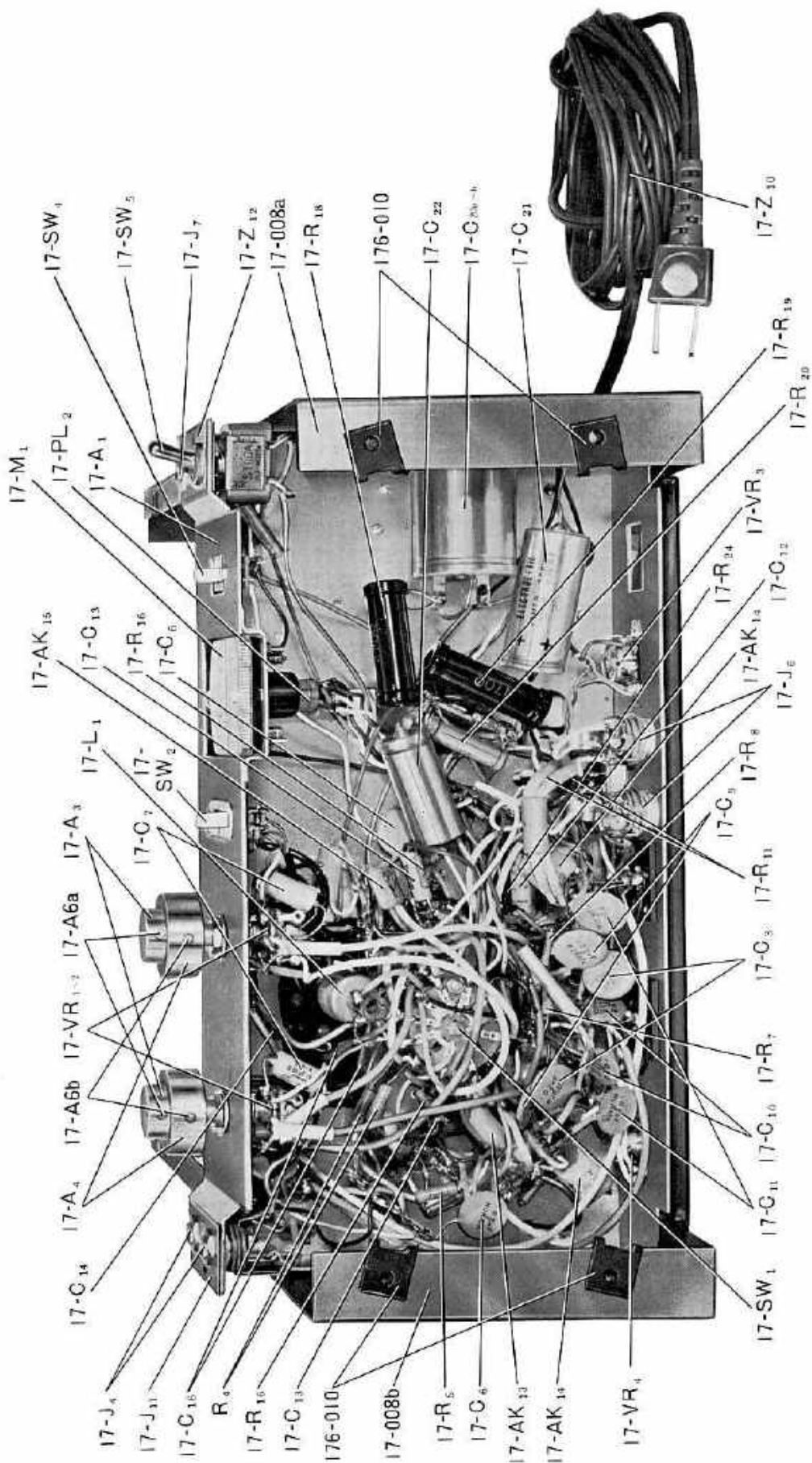

176-001

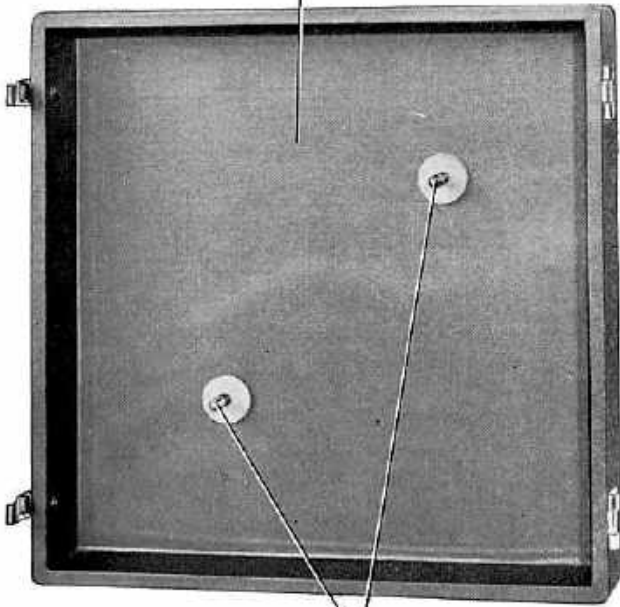

Case I

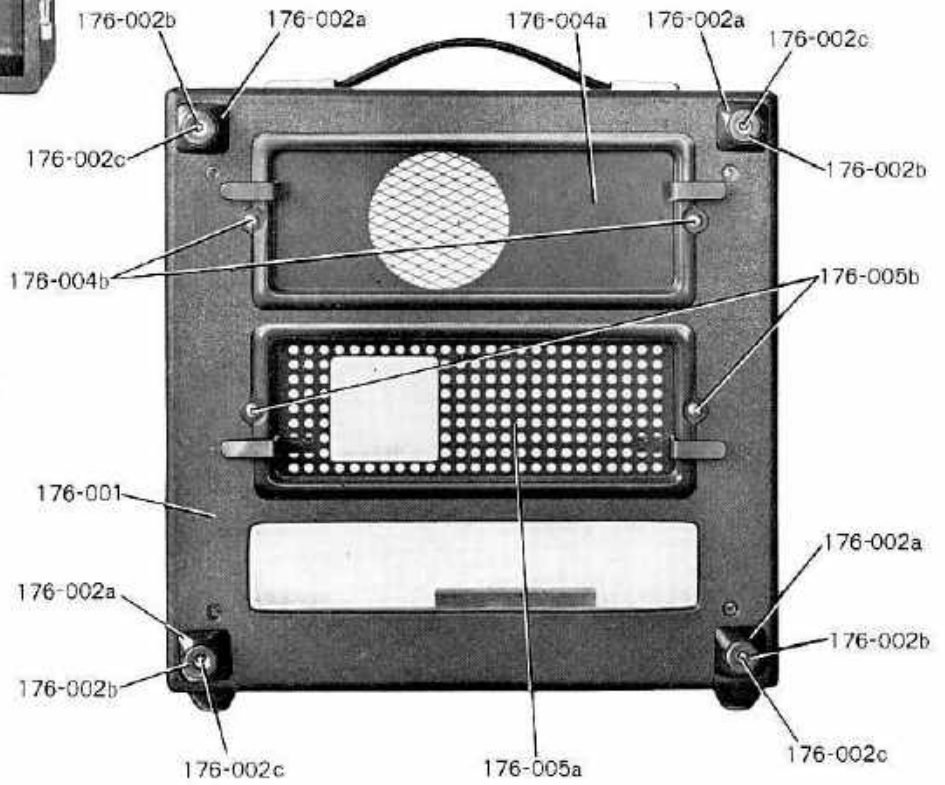

Case II

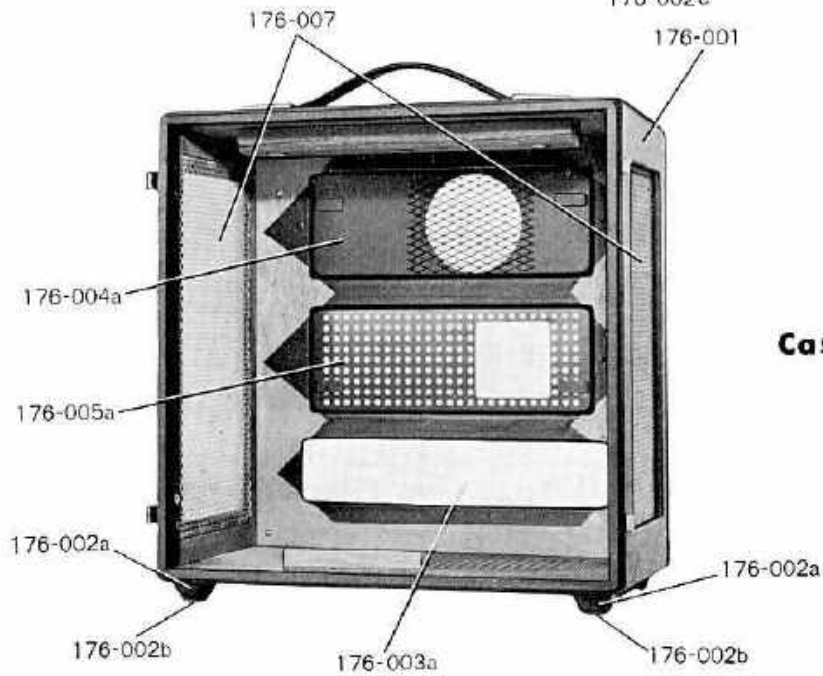

Case III

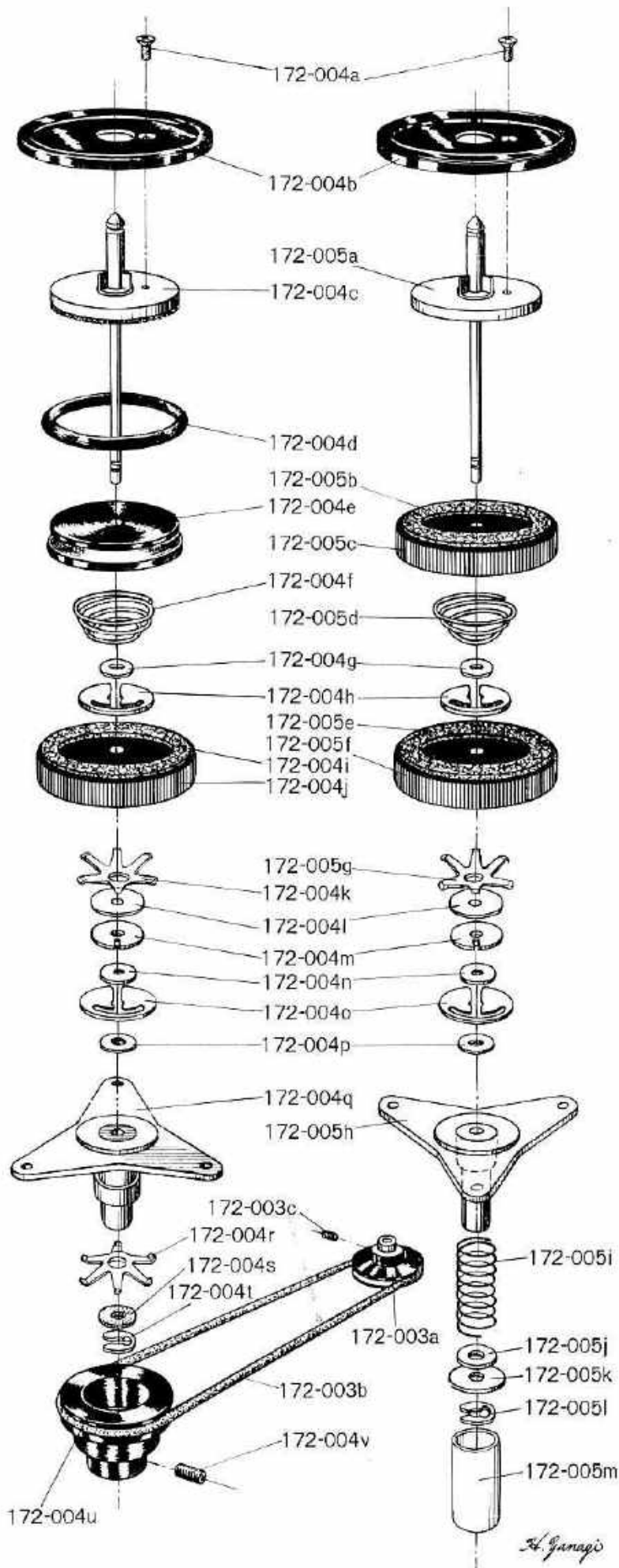

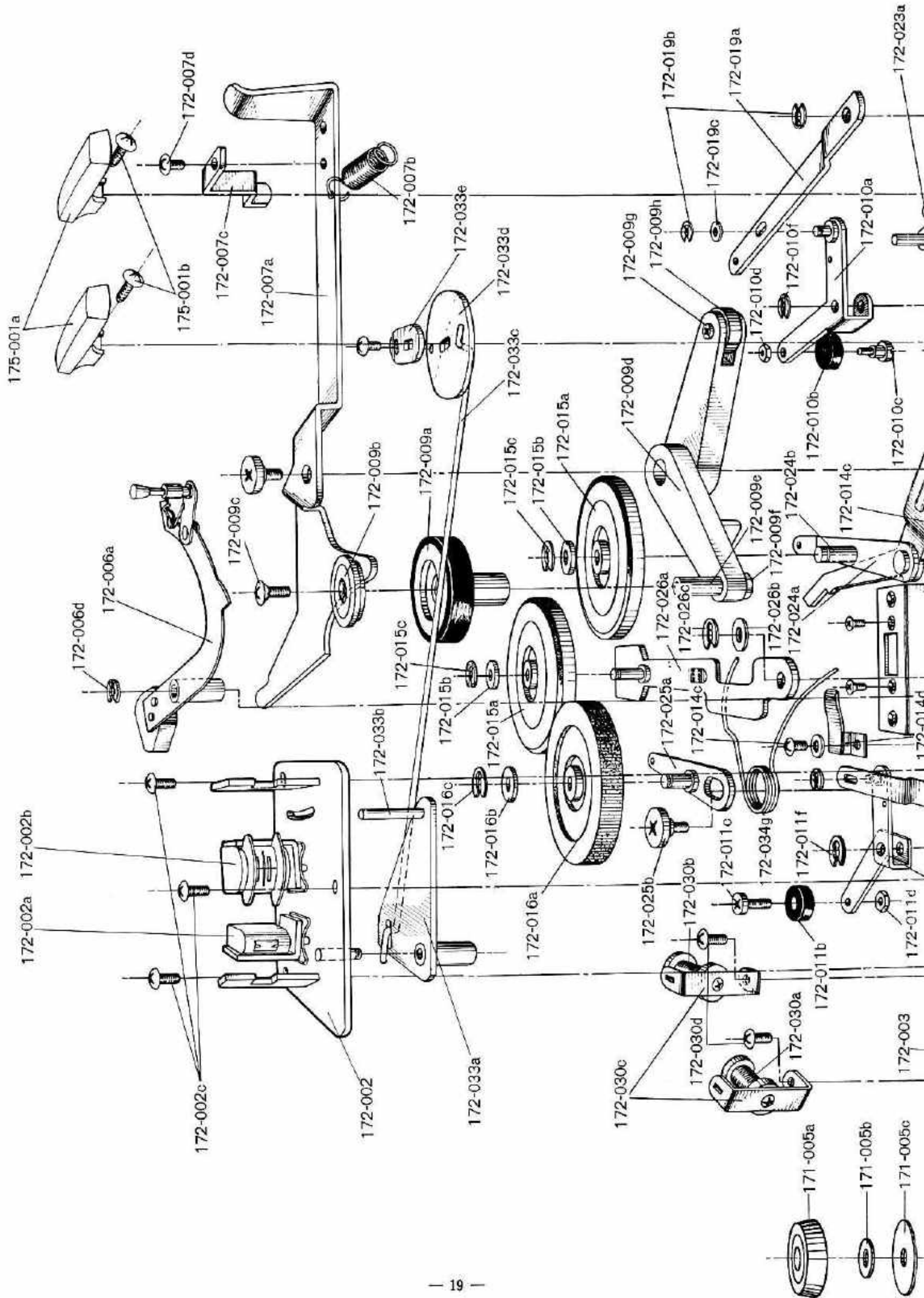

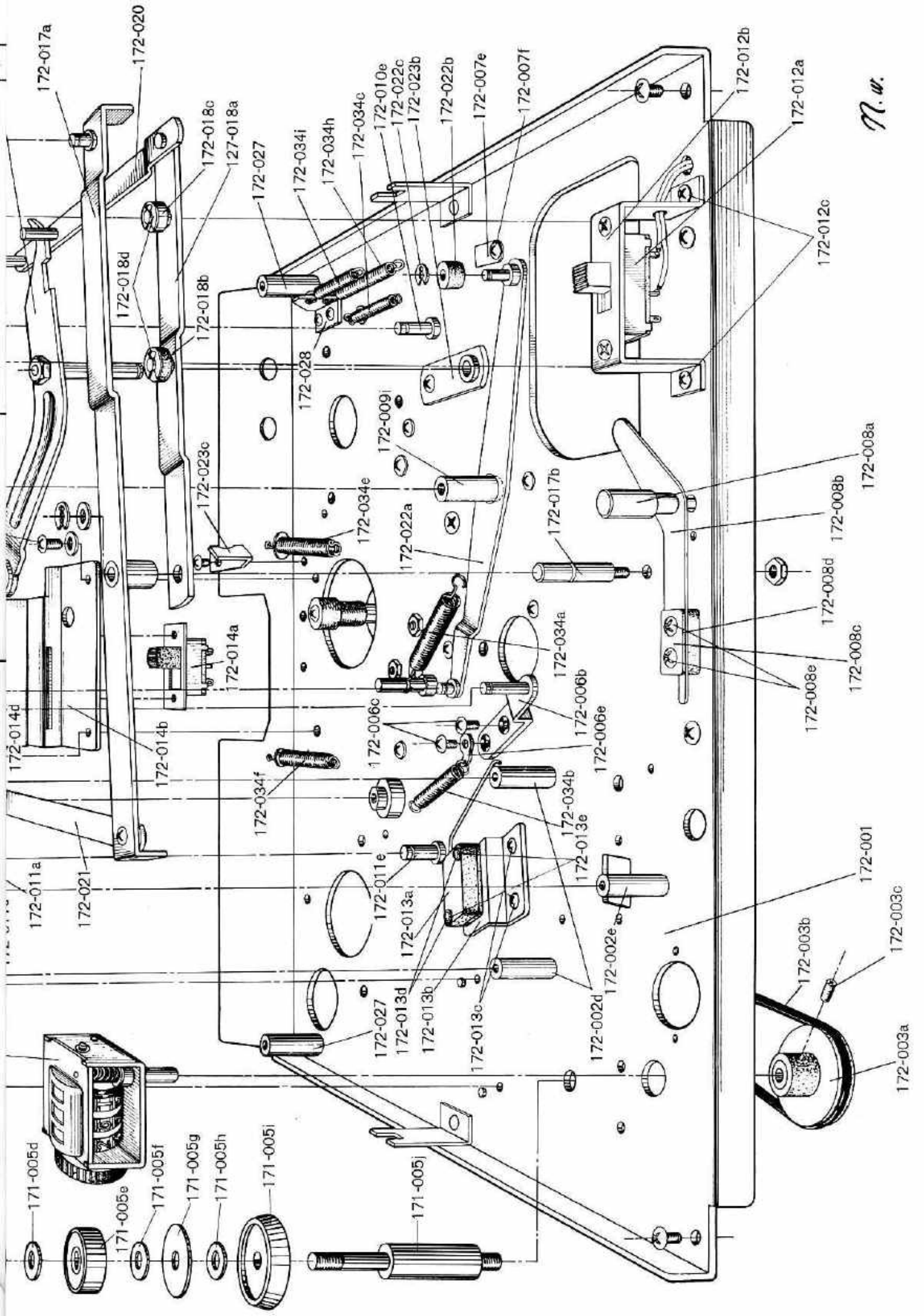

N. W.

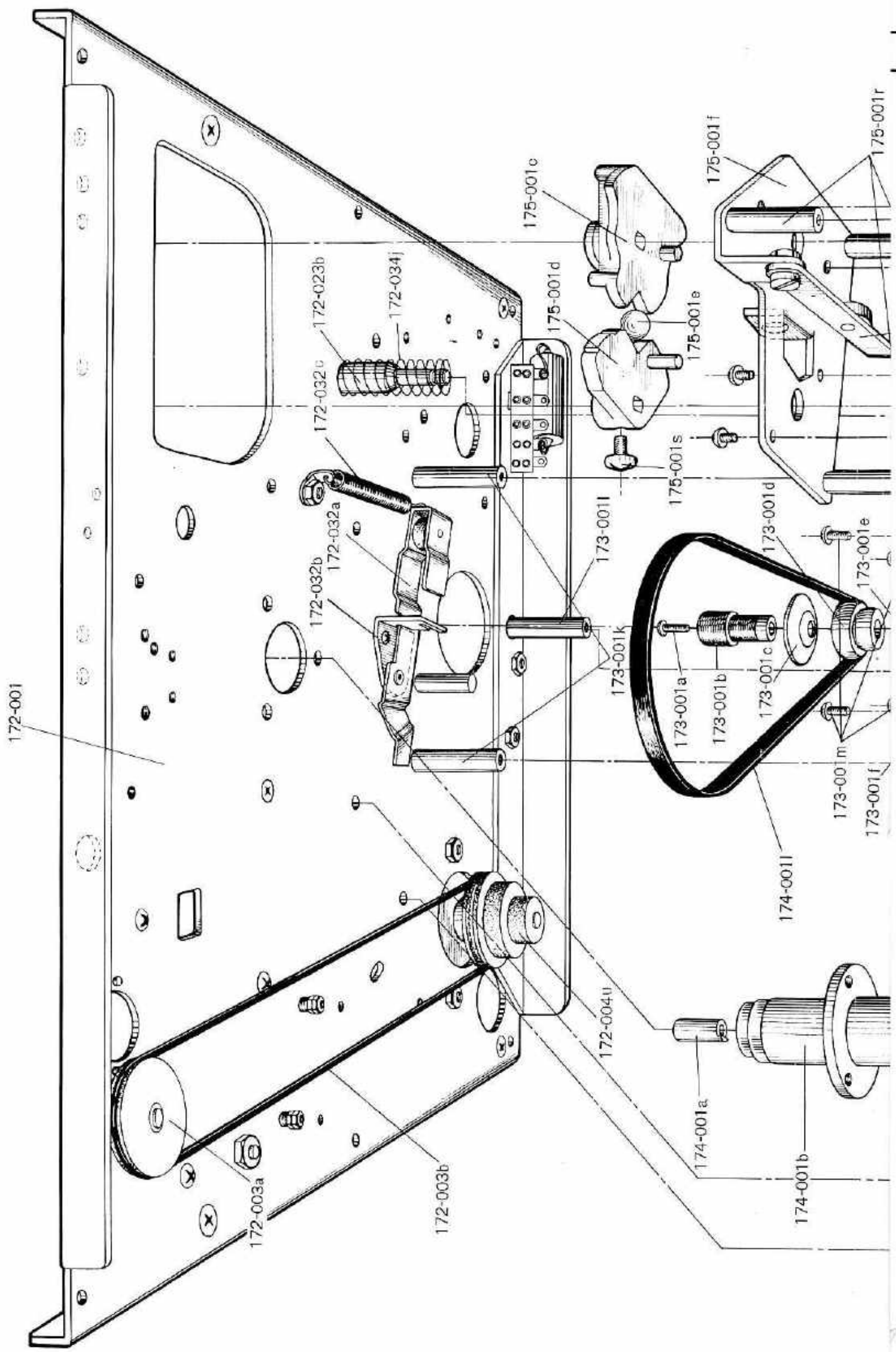

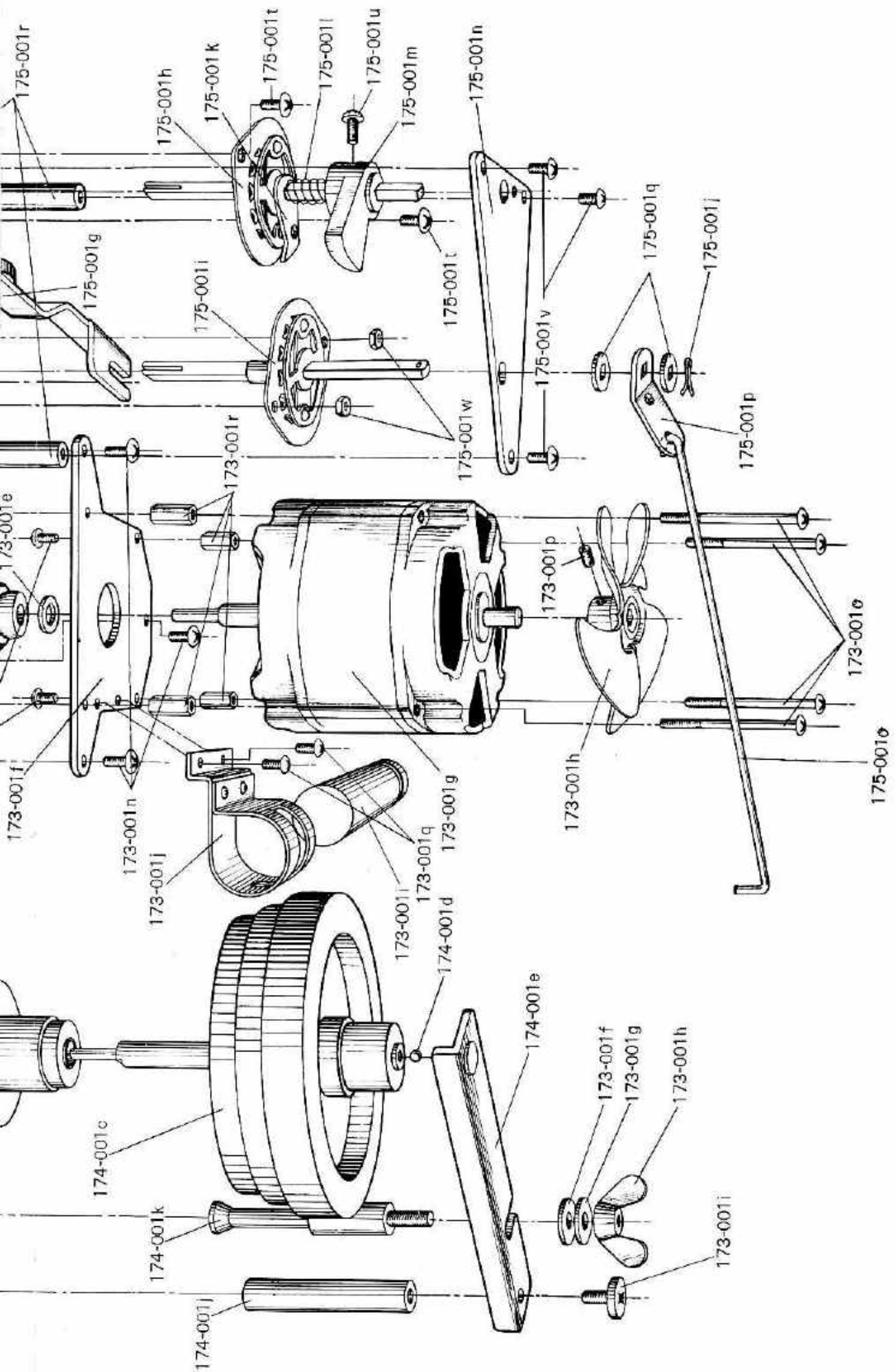

XI TROUBLE SHOOTING CHART FOR MODEL 1700

SECTION "A" TROUBLES WITH AMPLIFIER

1. Playback problems. (Unit set in play position.)

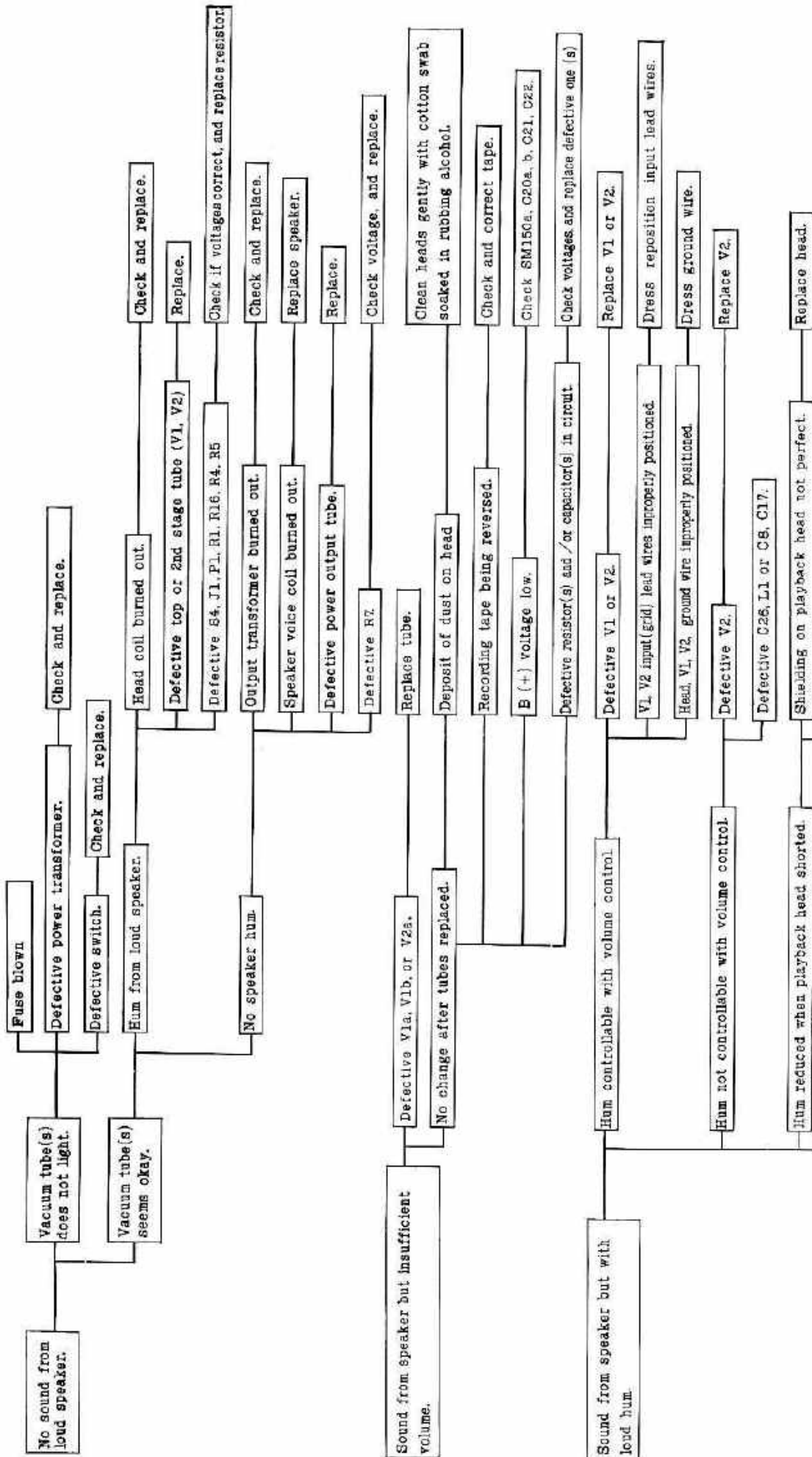

Defective C26, L1 or C8, C17.

Replace head.

Shielding on playback head not perfect.

Hum reduced when playback head shorted.

Check motor and power transformer, replace if necessary.

Leakage flux from motor or from power transformer.

Read just hum bucking coil.

Hum bucking coil out of adjustment.

Ground recorder at capstan storage post.

Unit picks up external magnetic flux.

Reposition recorder.

Hum recorded on tape.

Shield recorder.

Defective V1, C5, IM, MF Circuit.

Renew recording.

Hum recorded on tape.

Replace V1.

Defective V1, C5, IM, MF Circuit.

Check R1, R6, R8 or R11 and replace.

Defective R4, R5.

Replace V2.

Defective V2.

Check R7.

Defective R7.

Check and replace output transformer.

Output transformer being burned out.

Replace recording tape with new one.

Uneven coating on recording tape.

Demagnetize heads using head demagnetizer.

Tape heads being magnetized.

Replace V1, V2.

Defective V1, V2.

Check R1, R3 or R6.

Defective R1, R3 or R6.

Check C5, C7, C10, R2, VRI.

Defective C5, C7, C10, R2, VRI.

Lack of bass.

Replace recording tape.

Defective recording tape.

Clean tape heads.

Recording tape in close contact with tape heads.

Check supply reel shaft assembly and readjust spring tension.

Dust on tape heads.

Record/play head mis-aligned. (Azimuth alignment of gap in recording head)

Weak back tension.

Record/play head mis-aligned. (Azimuth alignment of gap in recording head)

Replace head assembly.

Worn-out tape heads.

Replace V1 or V2.

Defective V1 or V2.

Sound distorted.

Defective V1 or V2.

Check component parts in circuit by measuring voltage. See wiring diagram for regular voltage.

Incorrect circuit rating.

Replace loud speaker.

Defective loud speaker.

2. Recording Problems.

(Unit plays back pre-recorded tapes okay, but recording not satisfactory.)

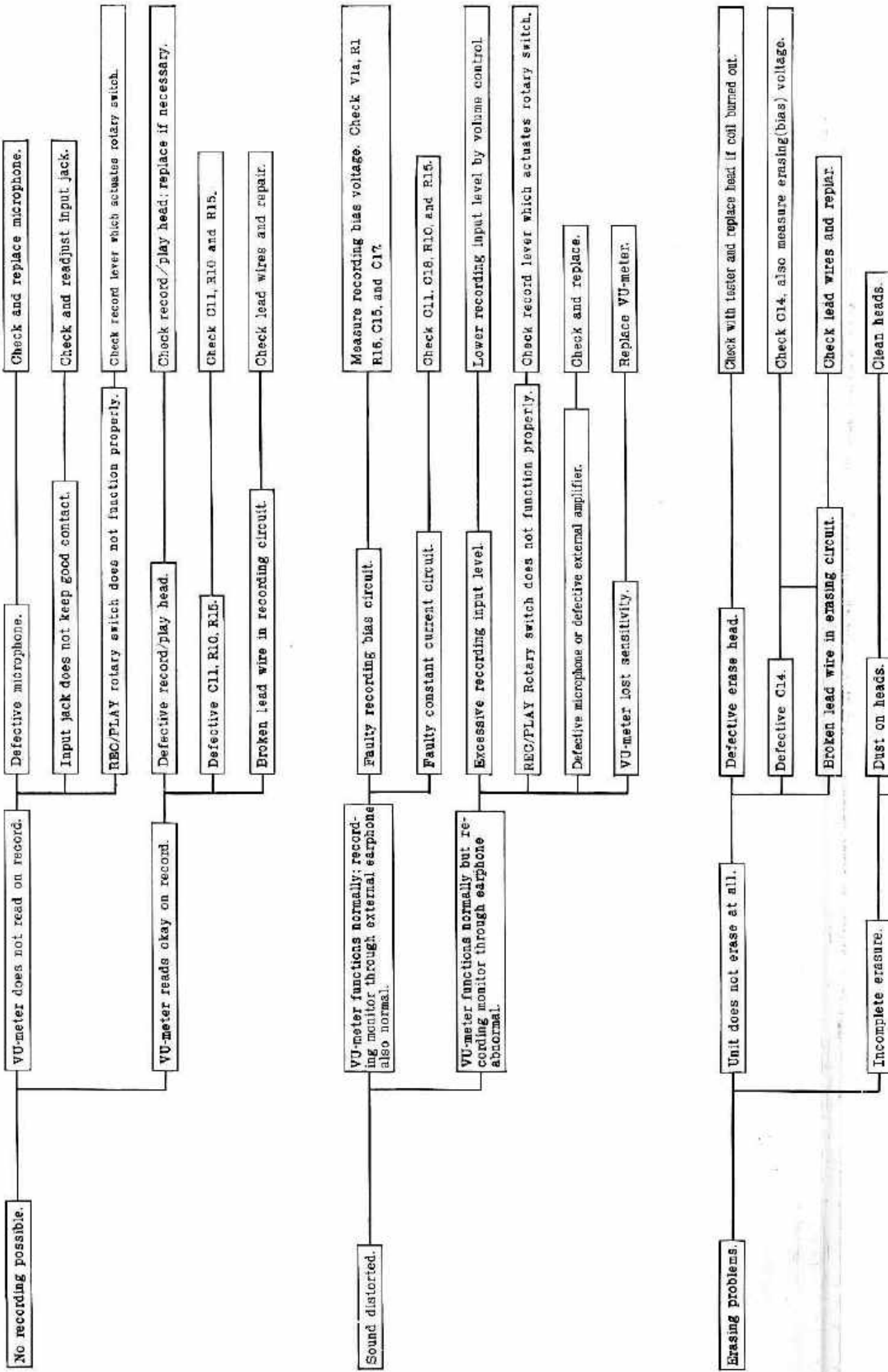

Incomplete erasure.
Dust on heads.
Clean heads.
Erasing bias voltage not high enough.
Check V1a, R1, R16, C17, C14.
Head coil being shorted.
Check and replace.

Insufficient treble on recording.
Dust on heads.
Clean heads.
Recording bias voltage out of adjustment.
Check bias voltage with VTVM (Vacuum Tube Volt Meter) and re-adjust to regular voltage.
Worn-out tape heads.
Replace head assembly.

Noisy recording. (Constant and loud background noise recorded on tape.)
Defective recording tape.
Replace recording tape.
Recording bias wave-form distorted.
Check V1a, L1, C17, C16, C14.

Low recording sensitivity.
VU-meter functions normally.
Recording tape lost sensitivity.
Check and replace tape.
Dust on heads.
Clean heads.
Defective head.
Check and replace head.
Defective R10 or R15.
Replace R10 or R15.

SECTION "B" TROUBLES WITH TAPE TRANSPORT MECHANISM.

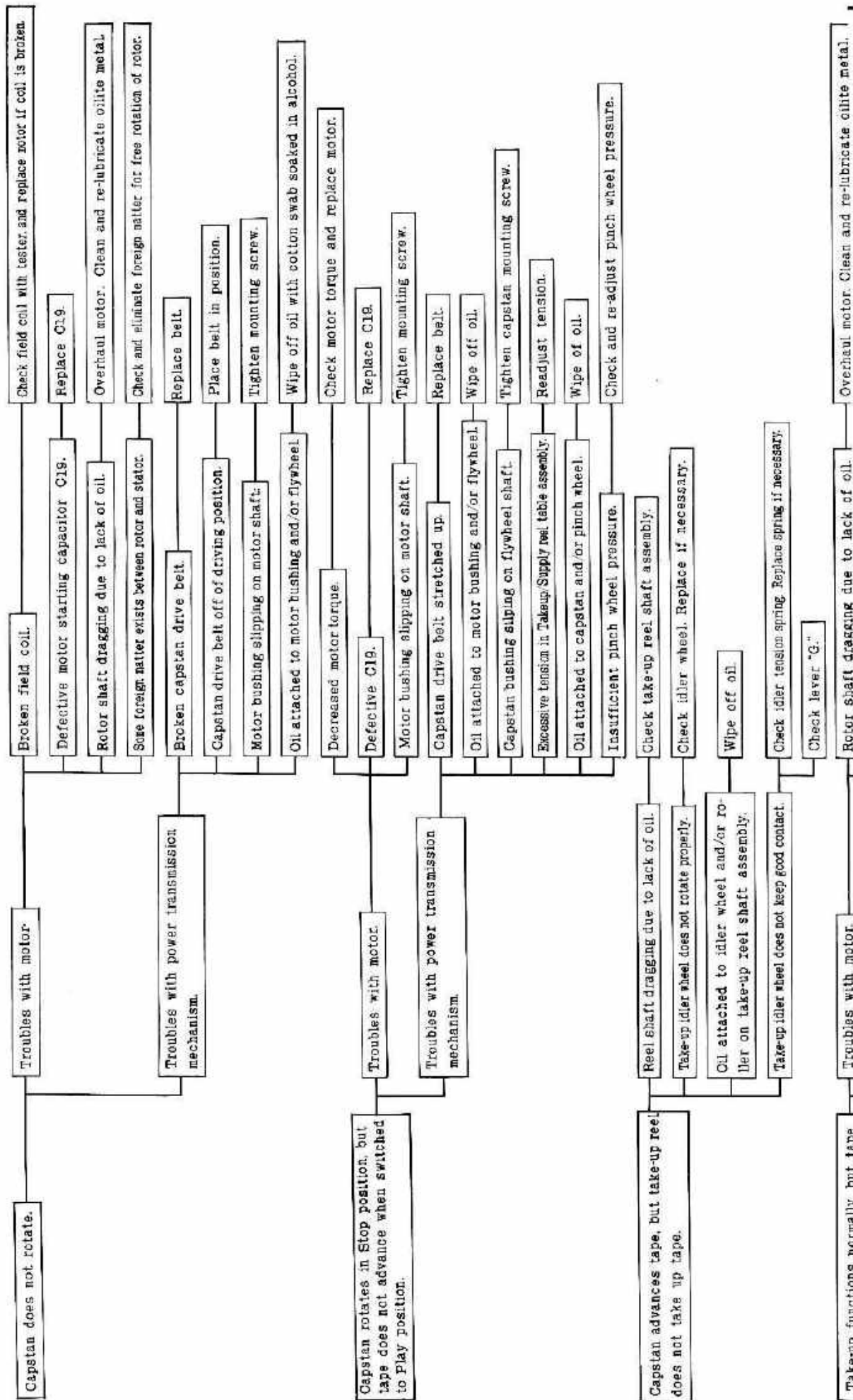

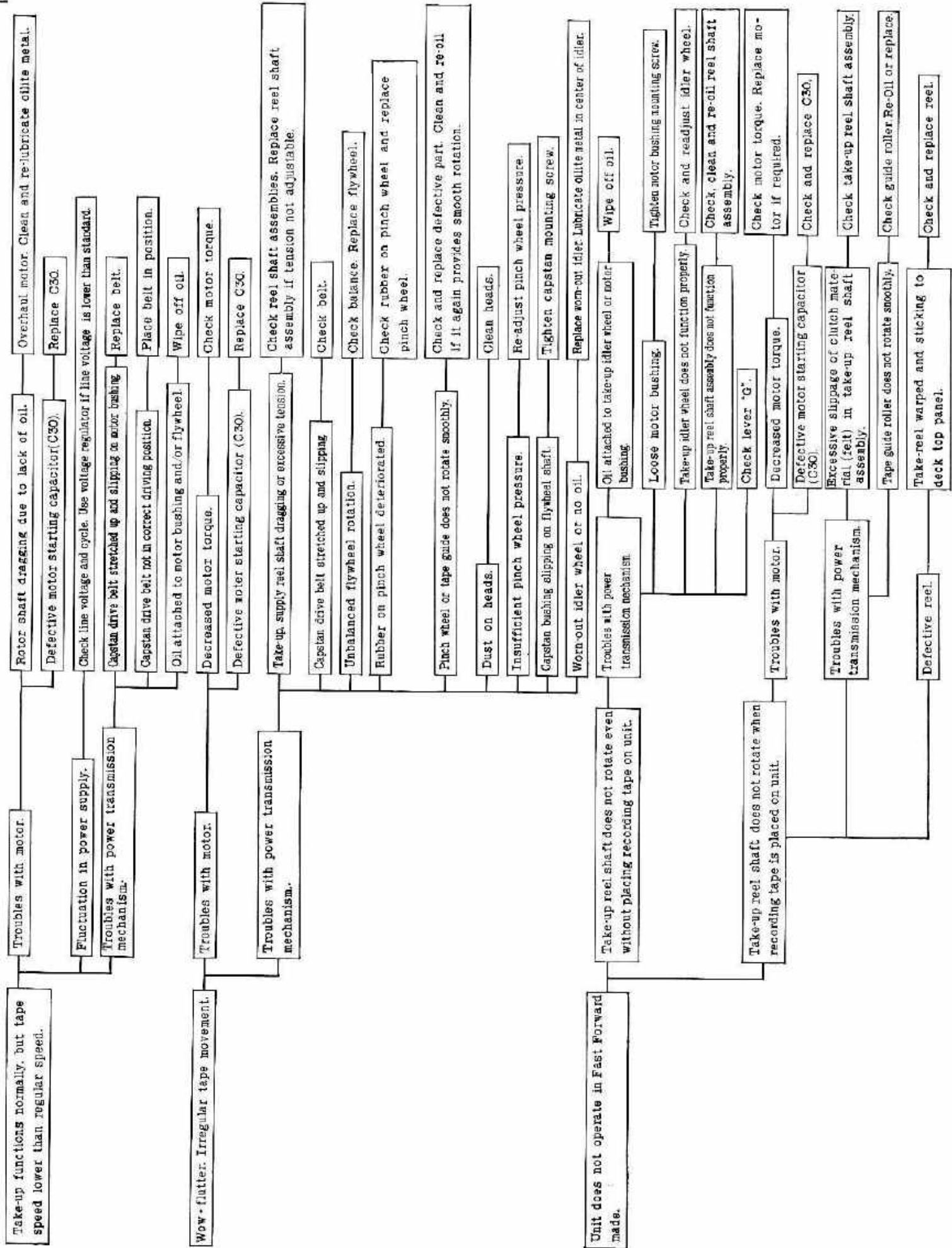

SECTION "B" TROUBLES WITH TAPE TRANSPORT MECHANISM.

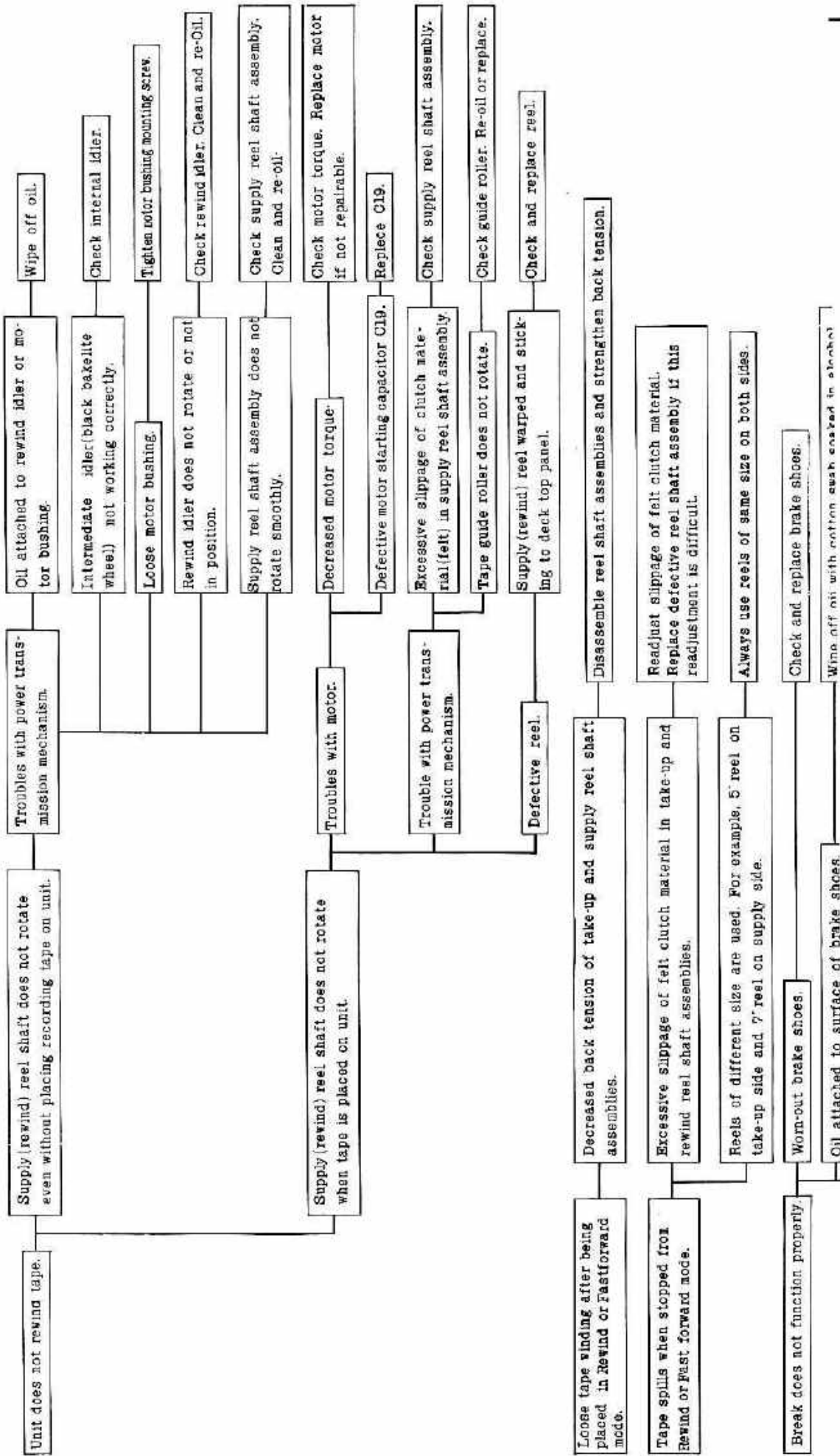

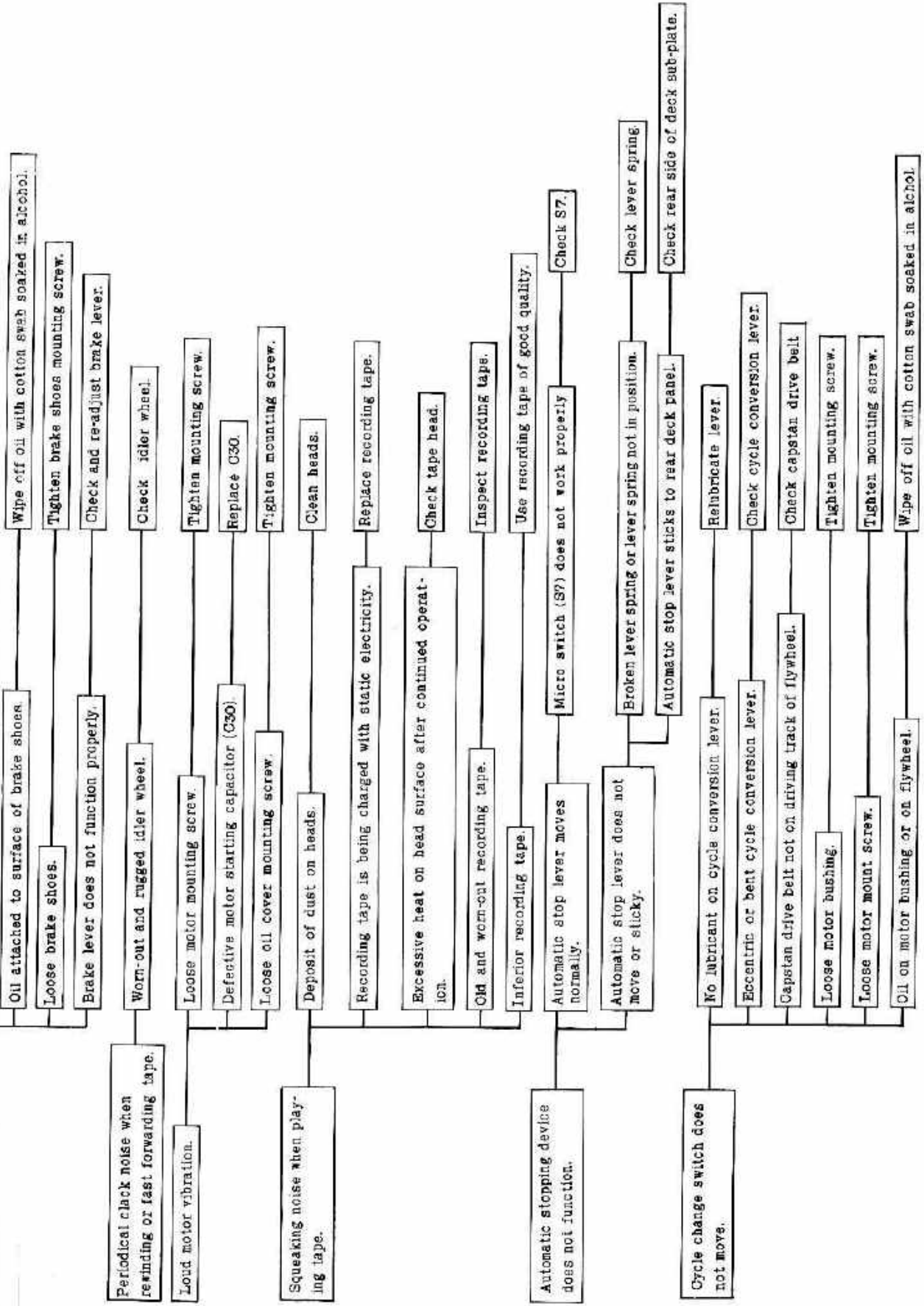

SCHEMATIC DIAGRAM

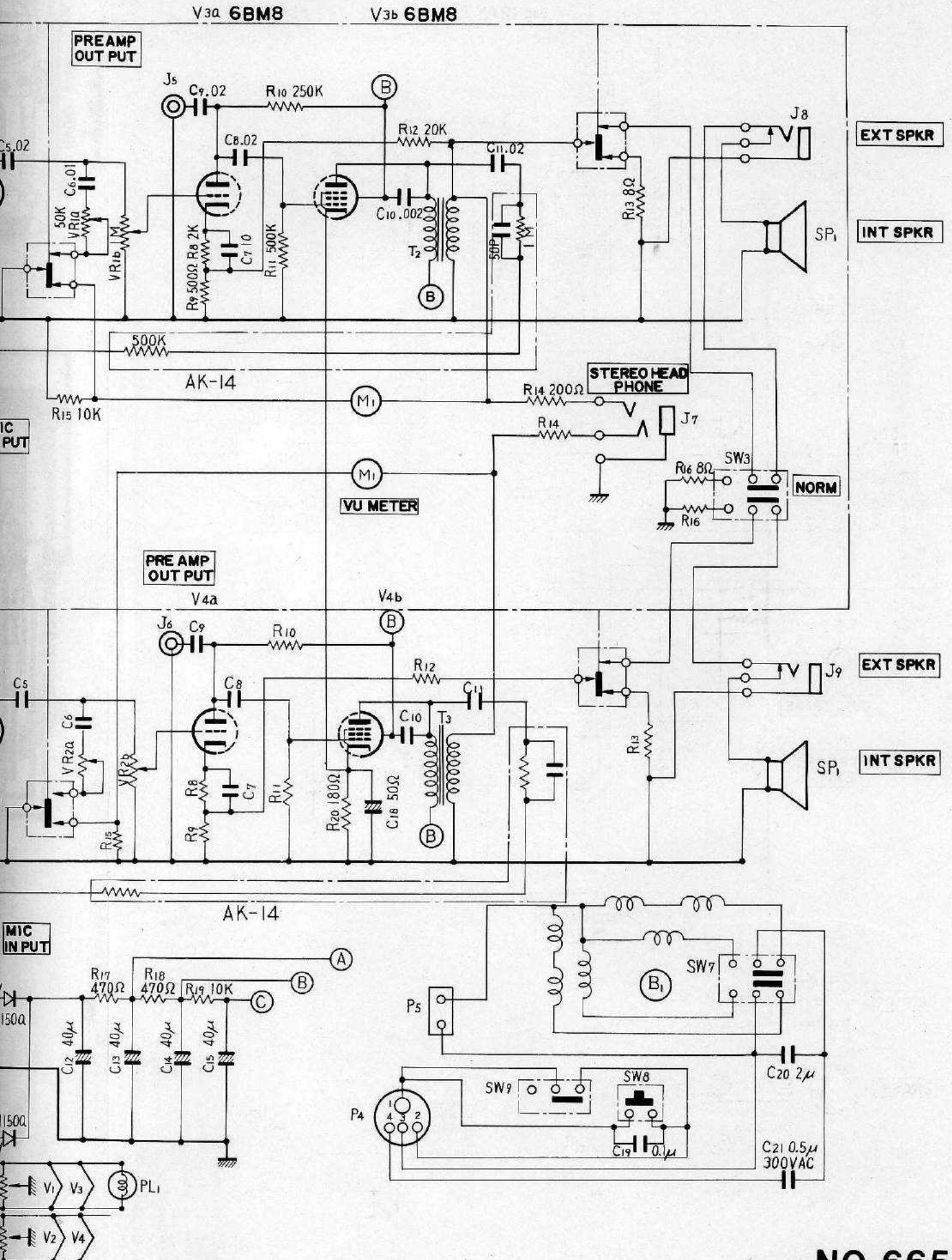

NO. 66505

XII SCHEMATIC

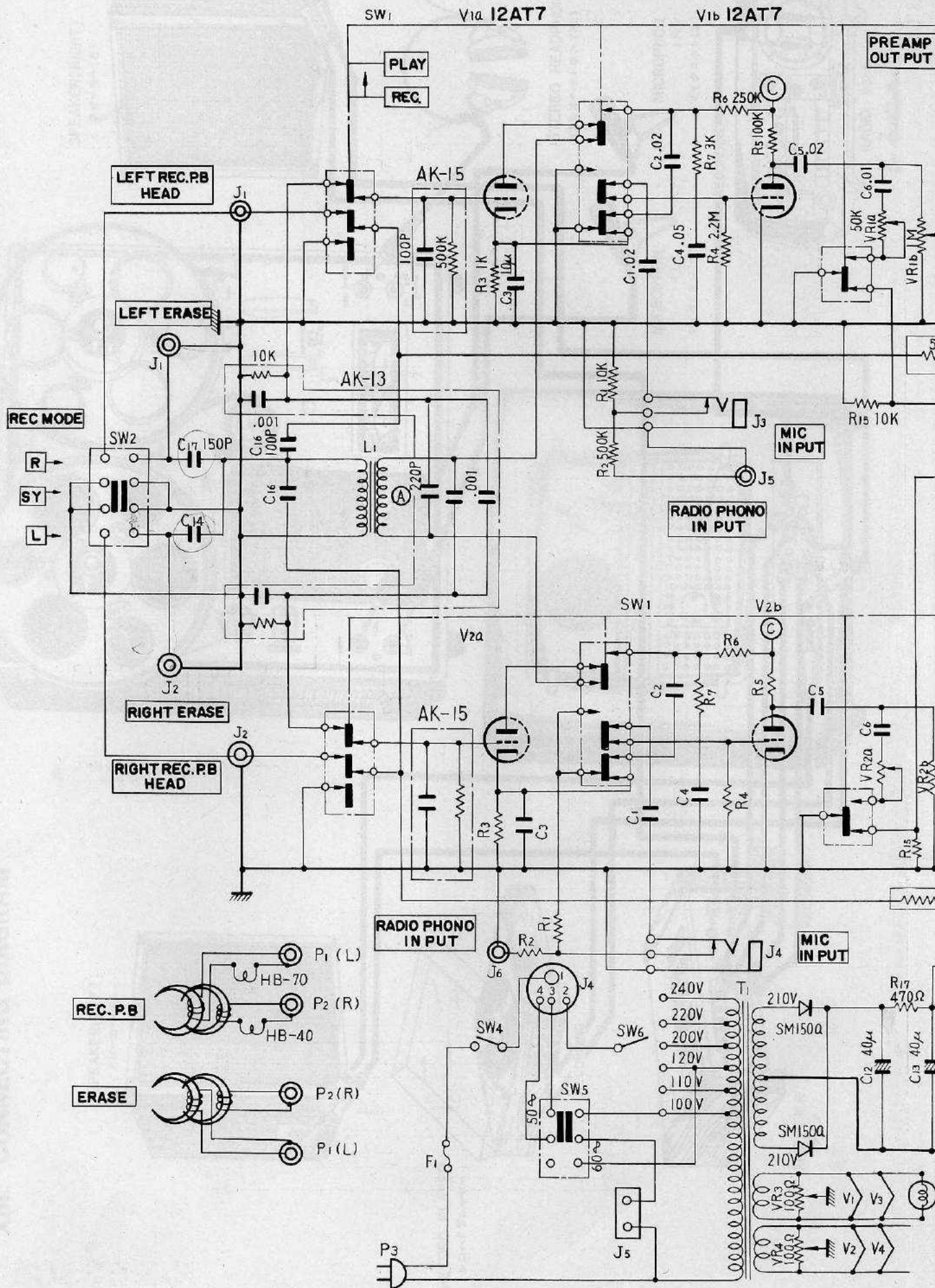

XIII. CONNECTING DIAGRAM

SPEAKER (LEFT)
スピーカー(左)

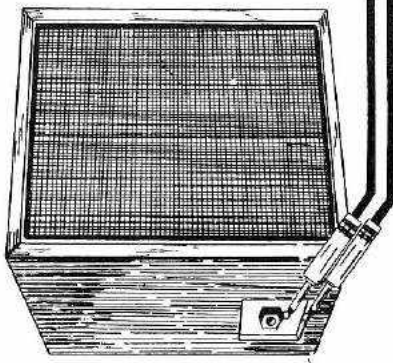

SPEAKER (RIGHT)
スピーカー(右)

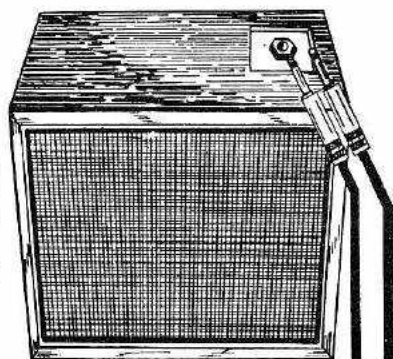

RECORD PLAYER
レコードプレーヤー

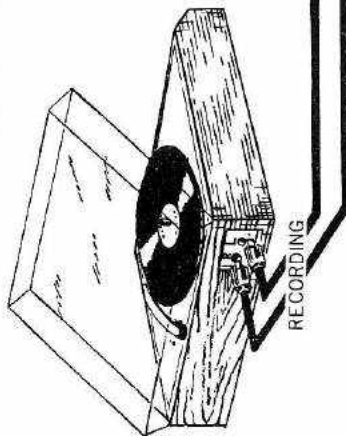

STEREO HEADPHONE
ステレオヘッドホン (8Ω)

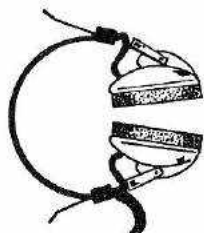

MICROPHON (R)
マイクホン(右)



MICROPHON (L)
マイクホン(左)



AMPLIFIER
アンプ

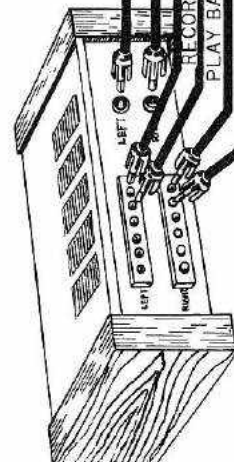

RECORDING

RECORDING

PLAY BACK

RECORDING

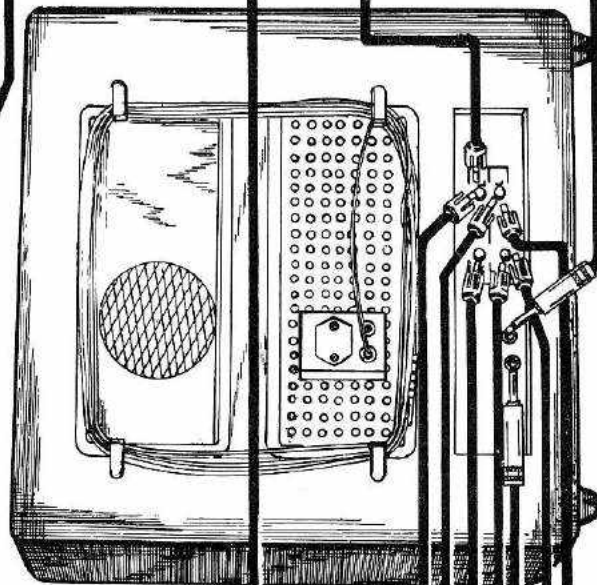
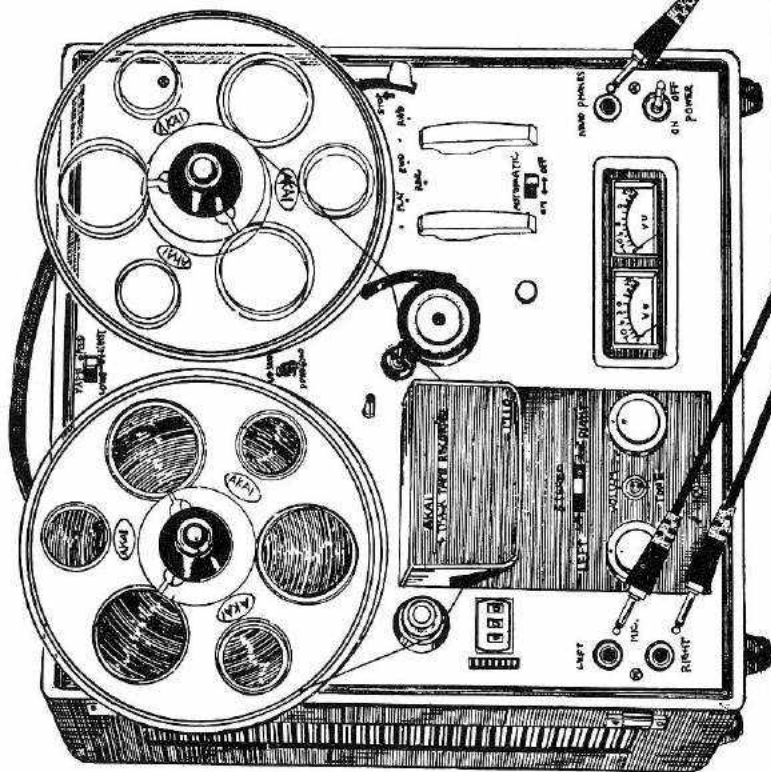

RADIO ラジオ

To Matsubara

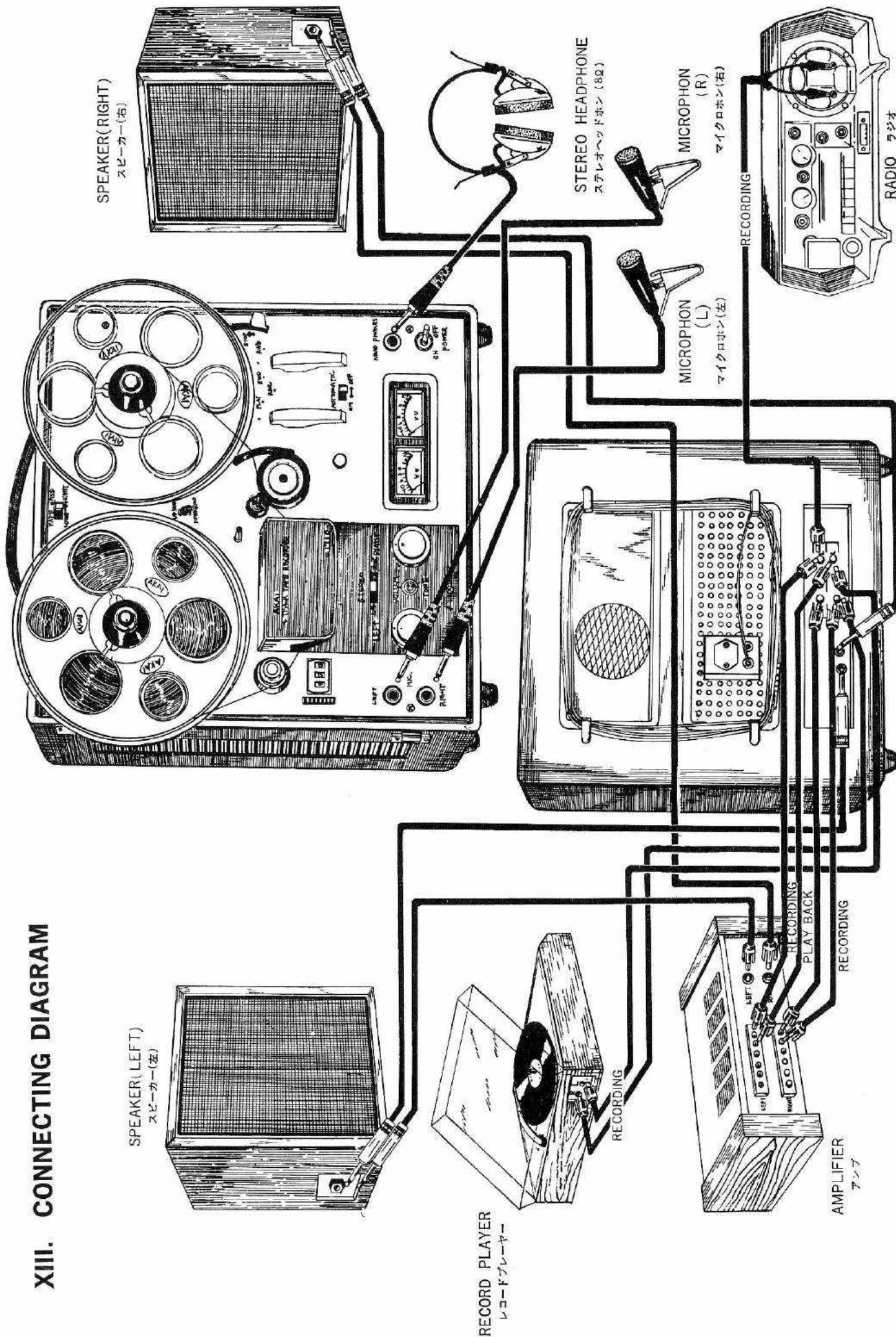
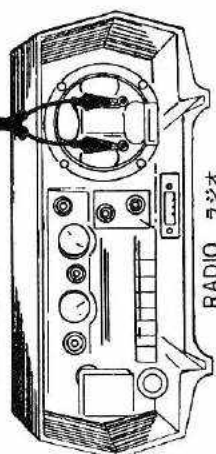



AKAI ELECTRIC CO., LTD.
AKAI TRADING CO., LTD.

**12, 2-chome, Higashi-Kojiya,
Ohta-ku, Tokyo, Japan.**