

SERVICE MANUAL

**AKAI SURROUND STEREO
TAPE RECORDER**

MODEL 1730-SS

ALSO APPLICABLE TO MODEL 1730D-SS



TABLE OF CONTENTS

I	SPECIFICATIONS	2
II	MEASURING METHODS	3
III	CONTROL LOCATIONS	5
IV	DISMANTLING OF TAPE TRANSPORT UNIT & AMPLIFIERS	6
V	TRANSPORT MECHANISM	8
VI	MECHANISM ADJUSTMENT	12
VII	AMPLIFIER ADJUSTMENT	14
VIII	MAINTENANCE PROCEDURES	16
IX	TROUBLE SHOOTING CHART	17
X	COMPOSITE VIEWS OF COMPONENTS	22
XI	SCHEMATIC DIAGRAM	

When placing order for parts, please use Separate
PARTS LIST or PRICE LIST FOR PARTS.

I. SPECIFICATIONS

WEIGHT	: 37.5 lbs. (17.0 kg)	FAST FORWARD & REWIND TIME	: 90 seconds 1,200 ft. tape at 50 Hz 70 seconds 1,200 ft. tape at 60 Hz
DIMENSIONS	: 18"(H) x 16.5"(W) x 9.5"(D) (H450 x W420 x D240 mm)	MONITOR SYSTEM (recording)	: <u>With Record/Playback Switch at "REC"</u> The program being recorded can be monitored by using: built-in speakers stereo headphones external speakers crystal receiver
POWER SUPPLY	: 100 to 240 V AC, 50/60 Hz	MOTOR	: Hysteresis synchronous 2 speed motor Horse Power : 1/100 HP Power Ratio : 85% Revolutions : 3,000 to 1,500 R.P.M. at 50 Hz 3,600 to 1,800 R.P.M. at 60 Hz Condenser capacity : 3 μ F at 50 Hz 2 μ F at 60 Hz
RECORDING SYSTEM	: In-line 4-track 4-channel stereo and 4-track 2-channel stereo recording	HEADS	
PLAYBACK SYSTEM	: In-line 4-track 4-channel stereo and 4-track 2-channel stereo playback	RECORDING HEAD	: In-line 4-track 4-channel stereo (4-track 2-channel stereo) Impedance : 125 Ω \pm 20% at 1,000 Hz Gap : 4/1,000 mm
POWER CONSUMPTION	: 80 W (Deck 55 W)	PLAYBACK HEAD	: In-line 4-track 4-channel stereo (4-track 2-channel stereo) Impedance : 1,200 Ω \pm 15% at 1,000 Hz Gap : 2/1,000 mm
TAPE SPEED	: 3-3/4, 7-1/2 ips.	ERASE HEAD	: In-line 4-track 2-channel stereo Impedance : 195 Ω \pm 10% at 100 KHz
TAPE SPEED DEVIATION	: Within \pm 1.5% at all speeds.	ERASE HEAD	: In-line Full track Impedance : 350 Ω \pm 10% at 100 KHz
WOW AND FLUTTER	: Less than 0.15% R.M.S. at 7-1/2" Less than 0.2% R.M.S. at 3-3/4"	TRANSISTORS & IC USED	: 2SC458LG (C) x 4 } RECORDING AMPLIFIER 2SC871 (E, F) x 4 } LD-3141 x 4 } 2SC458LG (C) x 8 } PLAYBACK AMPLIFIER LD-3141 x 4 } STK-011 (A) x 2 MAIN AMPLIFIER 2SC971 (2,3) (RED) x 2 BIAS OSC. 2SD223 (Y) x 1 POWER AMP.
FREQUENCY RESPONSE	: 30 to 22,000 Hz \pm 3 dB at 7-1/2" 40 to 13,000 Hz \pm 3 dB at 3-3/4"	DIODES	: IN34A x 4 VO6B x 4 10DC-1 (BLACK) x 1 RD-24A (M) x 1
SIGNAL TO NOISE RATIO	: More than 48 dB	REELS	: 7", 5" reels can be used.
DISTORTION (Total Harmonics)	: Within 2% at 1,000 Hz OVU recording (LINE OUTPUT) Within 3% at 1,000 Hz 5 W (when terminated with 8 Ω) (MAIN OUTPUT)		
CROSS-TALK	: Less than -50 dB (track) Less than -40 dB (channel)		
ERASE RATIO	: Less than 70 dB		
INSULATION RESISTANCE	: More than 50 M Ω		
INSULATION DURABILITY	: 1,000 V AC for more than one minute duration		
LINE OUTPUT	: +4 dB \pm 1.5 dB (1.228 V), at OVU indication, 250 Hz OVU recorded tape Required load impedance more than 25 K Ω		
POWER OUTPUT	: More than 5 W Impedance ; 8 Ω		
DIN OUTPUT	: -6 dB \pm 1.5 dB when using a 250 Hz recorded tape Required load impedance more than 50 K Ω		
LINE INPUT	: Above 40 mV Impedance ; 330 K Ω		
MIC. INPUT	: Above 0.4 mV Impedance ; 30 K Ω		
DIN INPUT	: Above 20 mV Impedance ; 100 K Ω		

II. MEASURING METHOD

TAPE SPEED DEVIATION

1. Method involving use of pre-recorded tape
Playback a tape pre-recorded at 1000 Hz ($\pm 0.1\%$) on recorder to be tested. Connect the appropriate output to a frequency counter meter in order to measure the tape speed deviation.
2. Method involving use of timing tape. (designed for tape speed measurement)
This method utilizes a timing tape marked at intervals of 7-1/2". The running time of over 60 marked sections of tape is measured in order to calculate the deviation of the tape speed. In applying this method, however, it should be kept in mind that timing tape stretch or contract measurement error is inevitable, so that it is necessary to measure the total length of the tape in advance.

WOW AND FLUTTER

Playback a 3,000 Hz pre-recorded tape, of which the wow and flutter level is guaranteed to be smaller than 0.07%, and measure with a wow meter. It is also possible for a 3,000 Hz sine wave to be recorded and played back for measurement with a wow meter. In this case, however, the wow meter will indicate a value as much as twice that given in the specifications.

SIGNAL TO NOISE RATIO

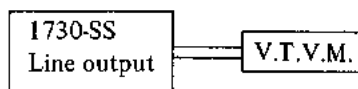

Set the Equalizer Switch to the "7-1/2 ips" position and playback a tape containing a 250 Hz sine wave recorded at "0" VU level on a standard recorder. Connect a V.T.V.M. to the line output jack of the recorder and measure its output. Next, remove the tape and measure the noise level under the same conditions. Convert each of the measured values into decibels.

TOTAL HARMONIC DISTORTION FACTOR

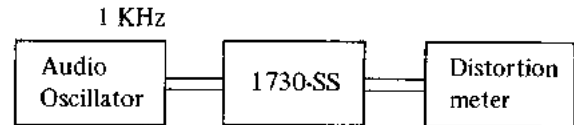

Connect the measuring instruments as shown above, and record a 1,000 Hz sine wave at "0" VU. Playback the resultant signal and measure the overall distortion factor. Measure the noise level of the tape recorder with the tape removed; connect the audio oscillator directly to the distortion meter for measurement of the distortion factor of the oscillator.

The resultant distortion factor can be obtained from the results of the above measurement by using the following formula :

$$d_0 = d - d_1 - d_2$$

where, d_0 = Required
 d = Overall distortion factor
 d_1 = Noise level
 d_2 = Distortion factor of the oscillator

(Note : New tape of particularly good quality should be used for measurement of the distortion factor. Fuji L is recommended).

POWER OUTPUT

Playback a tape containing a sine wave of 250 Hz recorded at "0" VU on a standard recorder.

Measure the Voltage at the output of the recorder to be tested when terminated with 8Ω .

Then use the following formula :

$$P = \frac{E^2}{R}$$

P = Desired output (W)
 E = Measured Voltage (R.M.S.)
 $R = 8 \Omega$

CROSS TALK

1. Between the tracks (2 Channel)

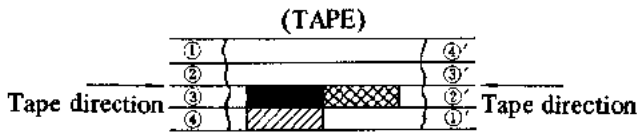

As shown in the figure, first record a 1,000 Hz sine wave on track No. 3 at +3 VU level. Next, remove the 1,000 Hz input signal and record under a non-input condition. Then, playback the tape on tracks 3 and 1 (reversed condition of tape) through the 1,000 Hz B.P.F. (Band Pass Filter, Sensitivity . . . 1 : 1) and obtain the ratio between the two by using the following formula.

$$C = 20 \log \frac{E_0}{E_2 - E_1} \text{ (dB)}$$

C = Desired cross talk ratio (dB)

E_0 = 1,000 Hz signal output level

E_2 = 1,000 Hz cross talk output level

E_1 = Non-input signal record level



2. Between the channels (4 Channel)

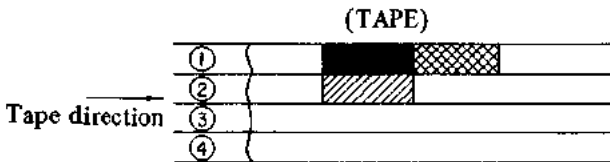

As shown in the figure, first record a 1,000 Hz sine wave on track No. 1 at +3 VU level. Next, remove the 1,000 Hz input signal and record under a non-input condition.

Then, playback the tape on track No. 1 and No. 2 through the 1,000 Hz B.P.F. (Band Pass Filter, Sensitivity . . . 1 : 1) and obtain a ratio between the two from the following formula.

$$C = 20 \log \frac{E_0}{E_2 - E_1} \text{ (dB)}$$

C = Desired cross-talk ratio (dB)

E_0 = 1,000 Hz signal output level

E_2 = 1,000 Hz cross-talk output level

E_1 = No-input signal record level



FREQUENCY RESPONSE

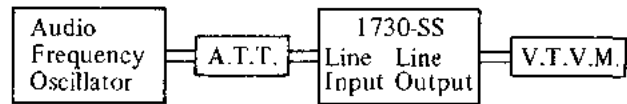

Connect the measuring instruments as shown in the above diagram, and measure the frequency response in the following sequence :

RECORD :

- 1) Introduce a sine wave of 1,000 Hz to the Line Input of the recorder being tested through an attenuator from an audio frequency generator.
- 2) Set the Record/Playback Lever to "Rec" position and adjust the line input volume so that the VU meter needle indicates "0" VU.
- 3) Under the conditions described in (2), lower the input level 20 dB with the attenuator.
- 4) Record the spot frequency from the audio frequency generator in the range of 30 to 23,000 Hz.

PLAYBACK :

- 5) Set the Record/Playback Lever to "Play" position.
- 6) Connect a V.T.V.M. to the Line Output.
- 7) Playback the previously recorded tape.
- 8) Adjust the output level to "0" dBm at 1,000 Hz (indicated on range selector of V.T.V.M.).
- 9) Playback the recorded spot frequencies under the conditions in (8) ; make a memo of Output Level and plot the value on a graph.

(Note : New tape of particularly good quality should be used for measurement of the frequency response. Fuji F tape is recommended).

In case of trouble, etc. necessitating disassembly, please disassemble in the order shown in photographs. Reassembly in reverse order.

III. CONTROL LOCATIONS

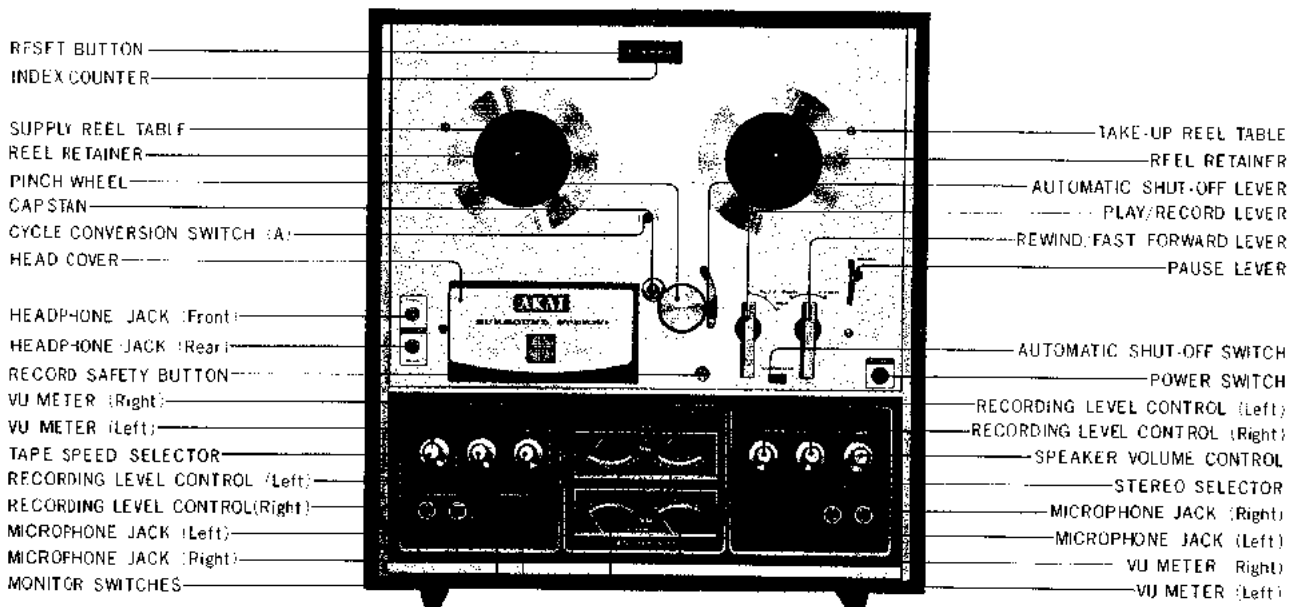

IV. DISMANTLING OF TAPE TRANSPORT UNIT & AMPLIFIERS

In case of trouble, etc, necessitating disassembly, please disassemble in the order shown in photographs. Reassemble in reverse order.

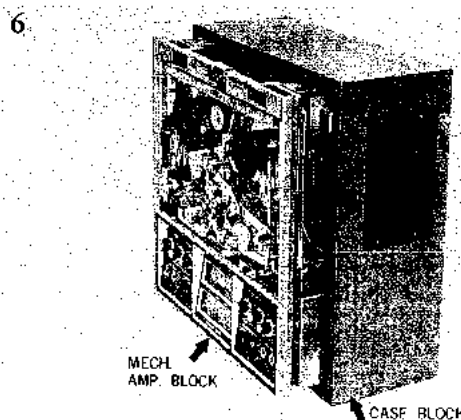
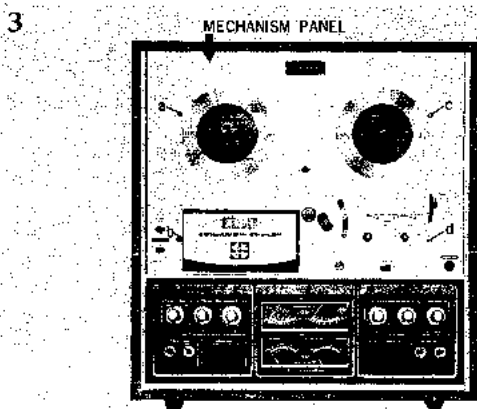
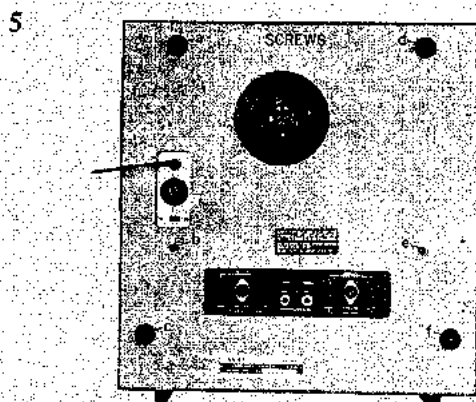
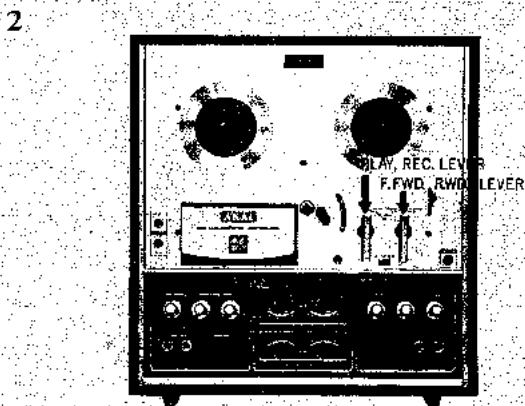
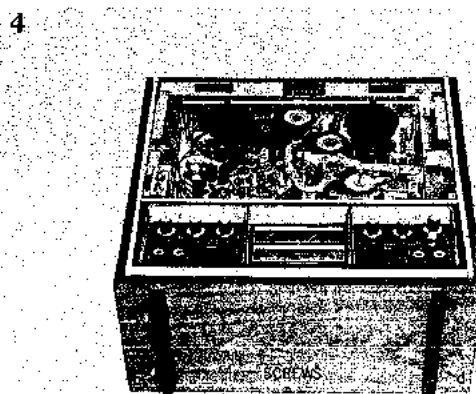
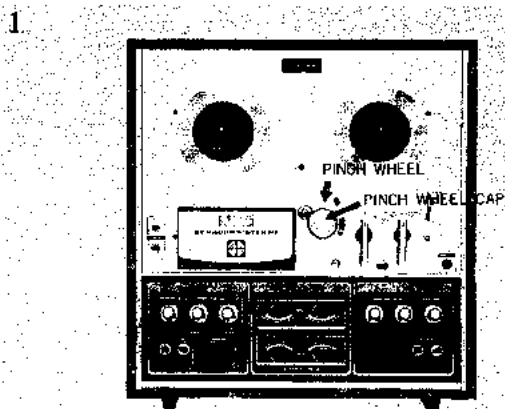

7

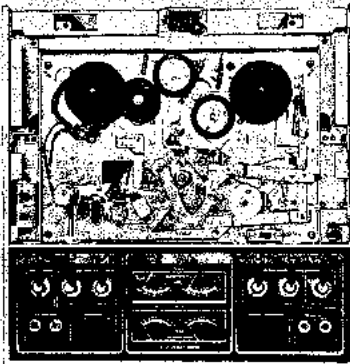

CONTROL KNOBS

10

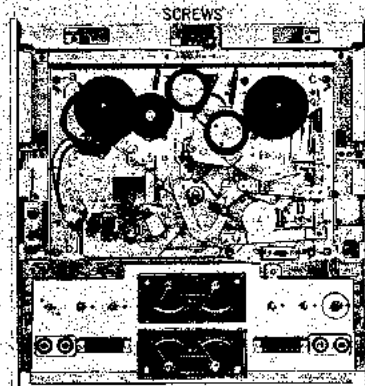

SCREWS

8

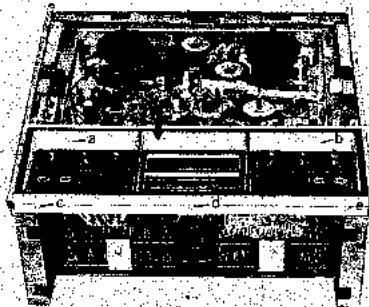

11

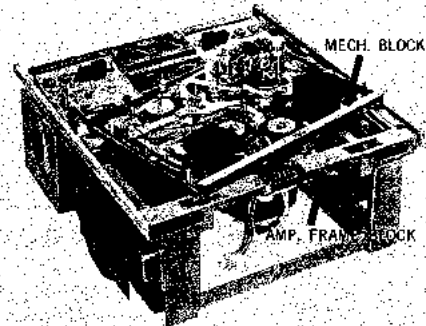

MECH. BLOCK

AMP. FRAME BLOCK

9

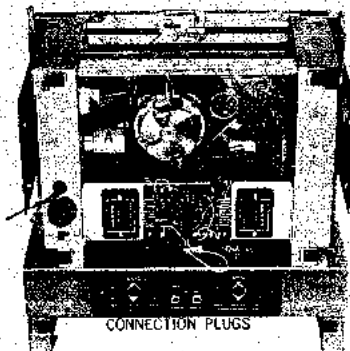

CONNECTION PLUGS

12



RETAINING PLATE

V. TRANSPORT MECHANISM

1. CAPSTAN DRIVE

Figure 1.

- (A) Motor
- (B) Drive Belt (flat belt)
- (C) Capstan
- (D) Flywheel

High-speed rotation of Motor (A) is transmitted by Drive Belt (B) to Capstan (C); which is connected to a flywheel that provides necessary inertia. This flywheel maintains the rated rotation and absorbs minor rotation variations of the motor.

Capstan Rotation :

606 R.P.M. at 7-1/2" (19 cm) per sec.

303 R.P.M. at 3-3/4" (9.5 cm) per sec.

151.5 R.P.M. at 1-7/8" (4.75 cm) per sec.

Motor Rotation :

3,000 to 1,500 R.P.M. at 50 Hz

3,600 to 1,800 R.P.M. at 60 Hz

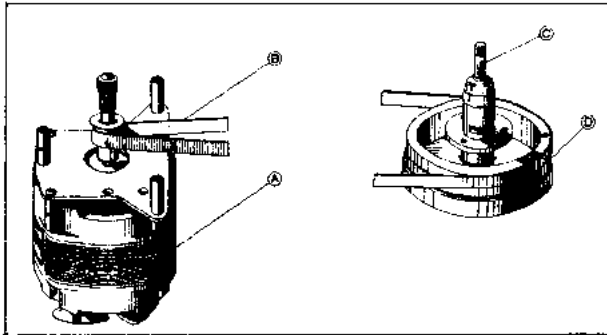

Fig. 1

2. PINCH WHEEL DRIVE

The pressure of the pinch wheel as it pushes against capstan, transports tape between rotating capstan and pinch wheel at the rated speed. The proper pinch wheel pressure is between 1,000 to 1,150 grams at the tape speed of 7-1/2" (19 cm) per second.

3. RECORD AND PLAYBACK MECHANISM

Turning the RECORD/PLAYBACK LEVER (A) to "PLAY" position causes the pinch wheel to press against the capstan and move the tape at the rated speed. At the same time, Idler (B) moves between Motor Bushing (C) and the Take-Up Reel Spindle (D) to transmit the motor rotation to (D) so that the tape is moved and wound on the take-up reel. The Take-up Reel Spindle Base, composed of two plastic wheels (discs) (1 and 2) with a felt clutch between, is rotated from below by the idler. Tape-winding friction is adjusted by the slipping of the felt and maintains rated winding of the tape. The Supply Reel Spindle (H) has a Brake Roller (E) contacting plastic wheel (disc) (4) from below which provides appropriate back tension by the slipping of the felt clutch to the rotation of the Pulley (3) above. To prevent accidental erasure, the Record Safety Button (F) must be depressed before the RECORD/PLAYBACK LEVER can be moved to the "REC" position. Safety device (G) is depressed to operate the recording mechanism.

(See figure 2)

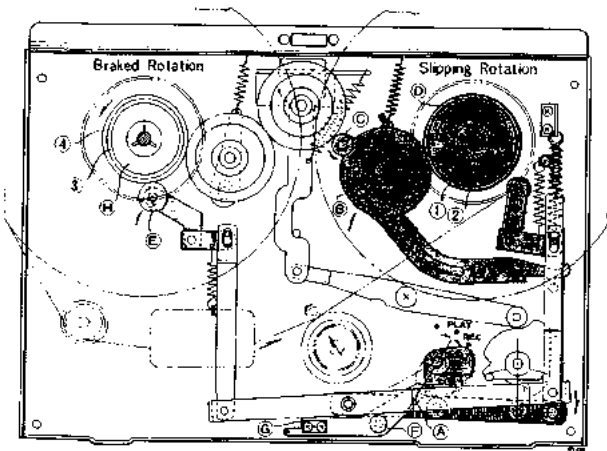

Fig. 2

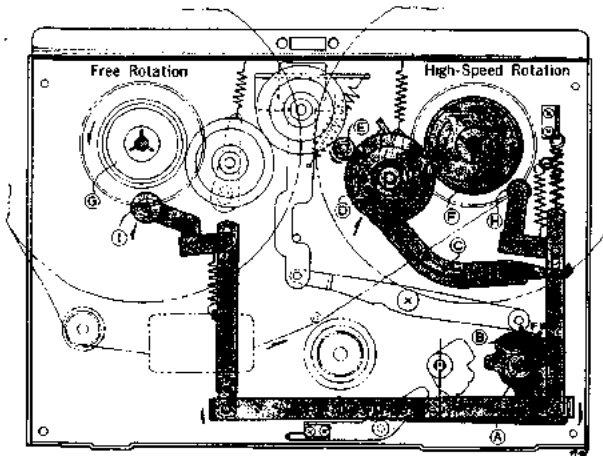

Fig. 3

4. FAST-FORWARD MECHANISM

Turning the *FAST FWD-REWIND LEVER* (A) to "FAST FWD" position, causes *cam* (B) under the knob to push up *Lever* (C). *Idler* (D) moves into the space between *Plastic Roller* (F) above the *Take-Up Reel Spindle* and the upper part of the rotating motor drive bushing to transmit the motor rotation to the take-up reel spindle. At the same time, *Brake Rollers* (H) and (I) come off the reel spindle to free *Supply Reel Spindles* (G) and (F), thereby allowing fast winding of the tape onto the take-up reel.

(See figure 3)

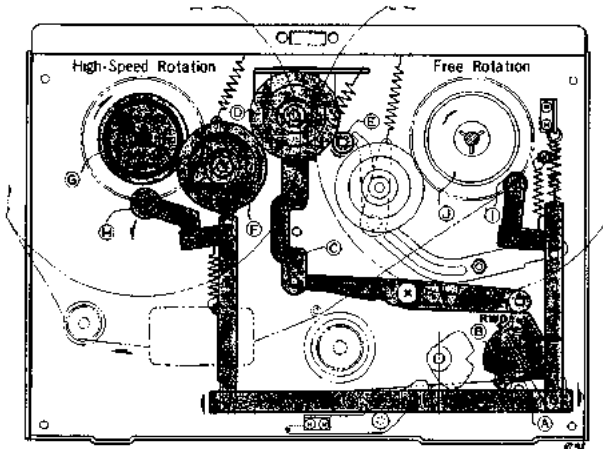

Fig. 4

5. REWIND MECHANISM

Turning the *FAST FWD-REWIND knob* (A) to "REWIND" position, causes *cam* (B) under the knob to push up *Lever* (C). *Idler* (D) moves into the space between the upper part of the rotating *Motor drive bushing* (E) and the *Intermediate Pulley* (F) to transmit the high-speed rotation of the motor through the intermediate pulley to *Supply Reel Spindle* (G). At the same time, *Brake Rollers* (H) and (I) come off the reel spindle to free *take-up reel spindles* (J) and (K), thereby rewinding the tape onto the supply reel at a fast speed.

(See figure 4)

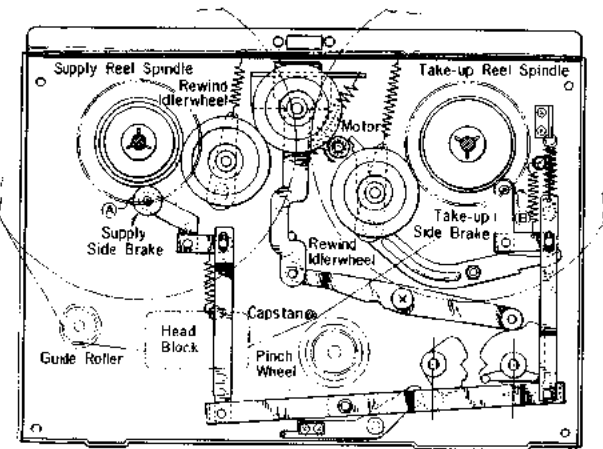

Fig. 5

6. STOP CONTROL

Turning the stop lever to "STOP" position, causes *Brake Rollers* (A) and (B) to depress the reel spindles and stop rotation.

As the brake rubbers depress the plastic rollers below the reel spindles, no friction is applied to the tape.

(See figure 5)

Modes of Operation	Pinch Wheel	Take-up Idler Wheel	Rewind Idler Wheel	Take-up side Brake	Supply Idler Brake
(a) STOP	X	X	X	○	○
(b) FAST-FORWARD	X	○	X	X	X
(c) REWIND	X	X	○	X	X
(d) RECORDING PLAYBACK	○	○	X	X	○

NOTES : X-marks indicates "open" and
○-marks "engaged"

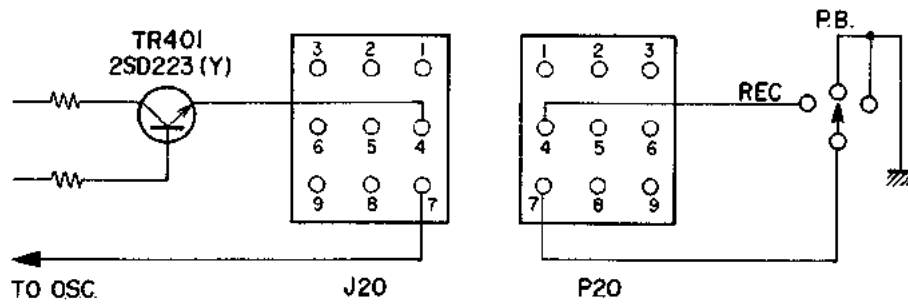

7. RECORD/PLAYBACK CHANGING MECHANISM

When the Rec/Playback Lever is switched from playback to recording position, the driving rotary switch is set to recording mode and voltage is applied to the recording amp as well as to the transmitting circuit.

8. 4-CHANNEL SURROUND STEREO SYSTEM

(1) Head Construction

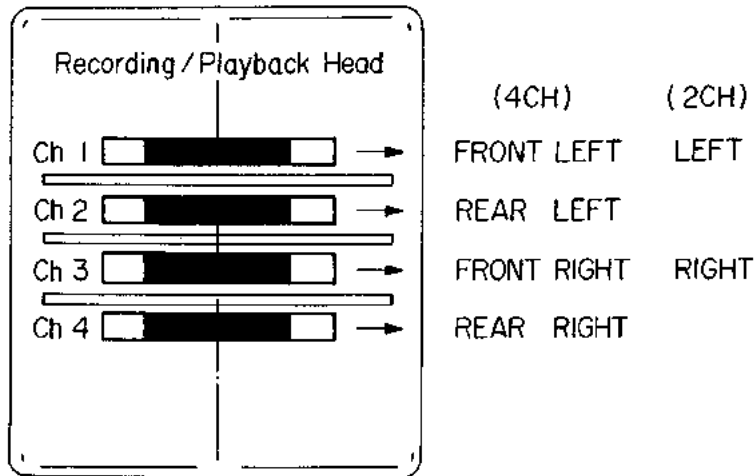

(2) ORDER OF HEADS

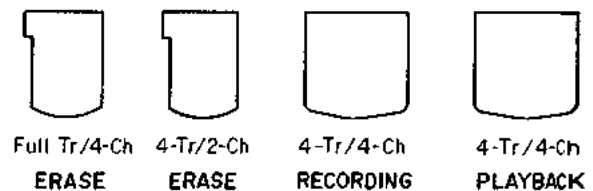

(3) BLOCK DIAGRAM WHEN SWITCHED FROM 2-CH TO 4-CH

1. During 2-Ch operation, the internal main amp serves tracks 1 and 3.
2. When switched to 4-Ch operation, the internal main amp is connected to serve channels 2 and 4 (Left Rear and Right Rear).
3. During 4-Ch operation, it is necessary for the external main amp to be connected for Front Channel operation (tracks 1 and 3).

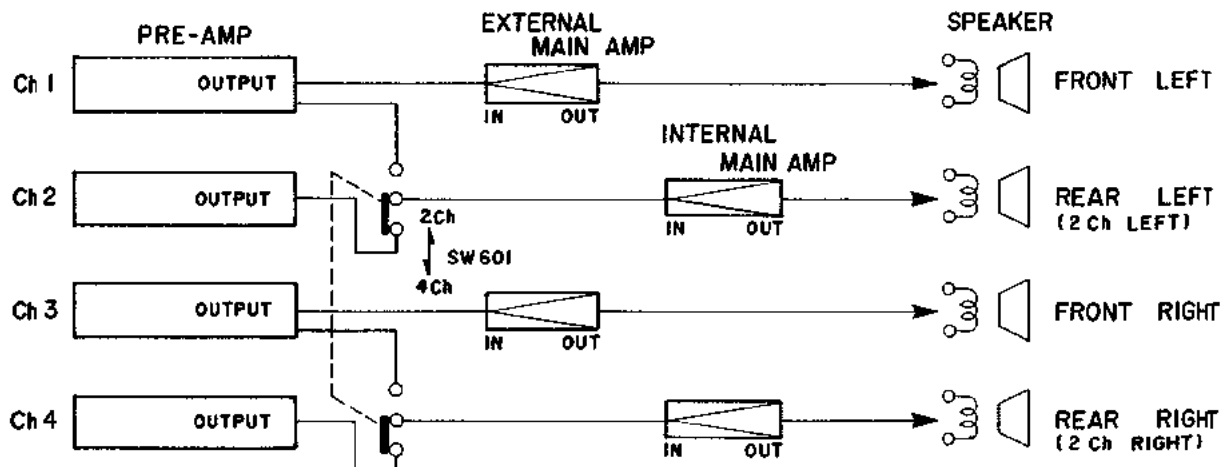

VI. MECHANISM ADJUSTMENT

1. PINCH WHEEL ADJUSTMENT

It is important that the pinch wheel shaft be kept in perfect alignment with the capstan shaft. Proper pinch wheel pressure is between 1,000 and 1,150 grams when the unit is operated at the tape speed of 7-1/2 ips. Any deviation will result in wow and flutter. Check pinch wheel pressure with a spring scale, and if necessary, adjust the pinch wheel load spring.

2. TAKE-UP IDLER WHEEL ADJUSTMENT

The take-up idler wheel must be kept in perfect alignment with the take-up reel shaft. In fast forward operation, the idler wheel contacts the upper knurled wheel of the take-up reel shaft assembly, and conversely contacts the lower knurled wheel during record or play operation. Adjust idler wheel load spring so that the idler wheel pressure is kept between 50 and 80 grams. The idler wheel wears rapidly if the pressure is excessive. Slippage occurs if the pressure is less than specified.

4. INTERMEDIATE WHEEL ADJUSTMENT

The intermediate wheel is located between the rewind idler wheel and the rubber ring which is used on the upper part of the supply reel shaft assembly. In rewind mode, it contacts these parts while simultaneously transmitting motor torque. An adequate pressure is 50 grams. Adjust the load spring of the intermediate wheel if the pressure is not sufficient.

5. TAKE-UP REEL SHAFT ASSEMBLY ADJUSTMENT

A felt clutch is attached to the bottom side of the reel table base plate so that recording tape will not stretch due to excessive tension during fast forward operation. To check the amount of friction on this part, install a 5-inch reel with a 60 mm diameter tape and gently pull the end of the tape upward with a spring scale. Adjust the conical spring so that the amount of tension on this part is between 350 to 450 grams. Another felt clutch is attached to the take-up drive wheel to provide proper slippage during record or play mode. The procedure for checking friction of this part is the same as the foregoing, and between 150 and 200 grams of friction provides the best results. Adjust the star-shaped spring just under the take-up drive wheel. During rewind operation, the amount of friction of this part will decrease to 10 to 15 grams. Check to see whether this is satisfactory. If not, readjust the star-shaped brake spring and the pressure of the spring retainer washer accordingly.

6. SUPPLY REEL SHAFT ASSEMBLY ADJUSTMENT

A felt clutch is used between the lower side of the reel table base plate and the rewind rubber ring to protect the recording tape from excessive tension during recording. To check the amount of friction on this part, install a 5-inch reel with a 60 mm diameter tape, and gently pull the end of tape upward with a spring scale. Adjust the conical spring so the tension is between 350 and 450 grams. Another felt clutch is attached to the rewind drive wheel to provide proper slipping operation during record or play mode. The procedure for checking friction on this part is the same as the foregoing, and between 110 and 130 grams of friction gives best results. In fast forward operation, the amount of friction will decrease to 10 to 15 grams.

Check to see whether this is correct. If not, readjust coil spring and spring retainer washer. (See figure 1 (a) at left).

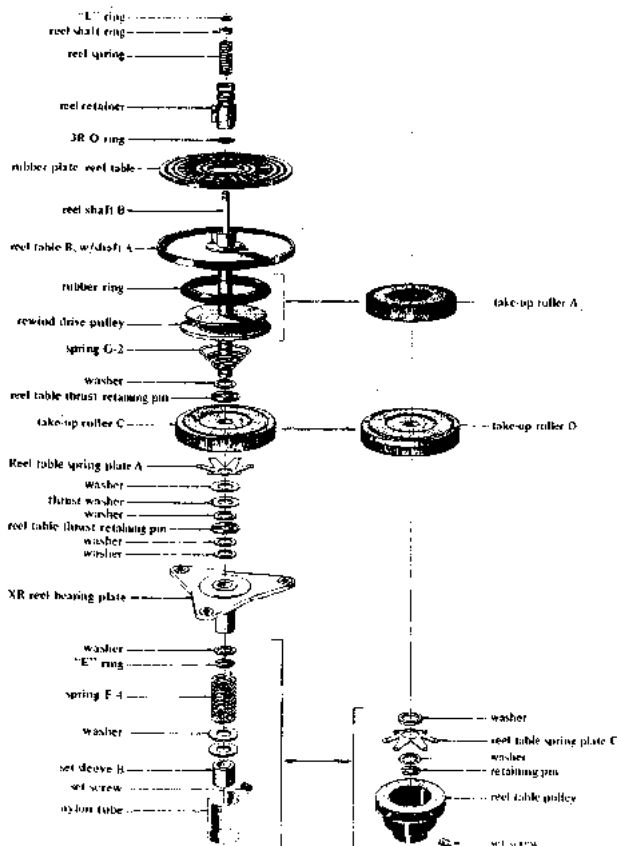

Fig. 1

3. REWIND IDLER WHEEL ADJUSTMENT

The rewind idler wheel must be kept in perfect alignment with the rewind reel shaft. The amount of pressure on the knurled motor bushing should be about 50 grams during rewind operation. Adjust both the idler load spring and rewind roller.

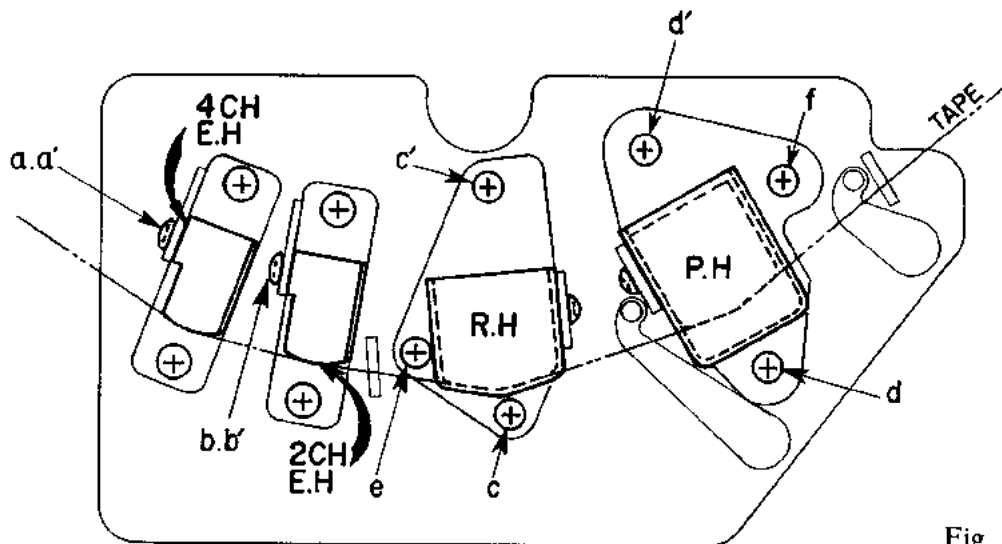

Fig. 2

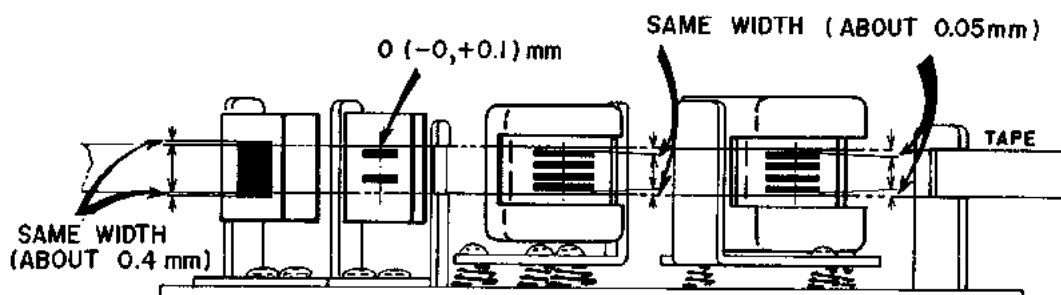

Fig. 3

7. HEAD ADJUSTMENT

(A) Adjustment of Head Height (See Fig. 2 and 3)

- a. Erase Head (2-Ch)
Adjust the Erase Head Height by turning head height screws (a) (a') so that the upper edge of the tape as it passes the erase head is 0 (-0, +0.1) mm top edge of the CH-1 erase head core.
- b. Erase Head (4-Ch)
With height control screws (b) (b'), adjust so that the width of the head protruding from both sides of the tape is exactly the same (about 0.4 mm at both top and bottom).
- c. Recording Head
With height control screws (c) (c'), adjust so that the width between the upper edge of track 1 head core and the upper edge of the tape is equal to the width between the lower edge of track 4 head core and the lower edge of the tape (about 0.5 mm).
- d. Playback Head
With height control screws (d) (d'), adjust so that the width between the upper edge of track 1 head core and the upper edge of the tape is

equal to the width between the lower edge of track 4 head core and the lower edge of the tape (about 0.05 mm).

(B) Adjustment of Vertical Azimuth of the Head

Adjust the vertical azimuth of each head (Record and playback) by turning head height screws (c) (c') and (d) (d') until the tape comes in complete contact with each head.

(C) Adjustment of Head Alignment

- a. Playback Head
Playback an Ampex Alignment tape (8,000 Hz) at 3-3/4 ips and turn alignment control screw (f) until the output level of both channels reaches maximum.
- b. Recording Head
At recording position, supply a 8,000 Hz sine wave at a -10 dB recording level from an Audio Frequency Oscillator to the Line Input of the 1730-SS, and set the SOURCE/TAPE Monitor Switch to "TAPE" position. Then turn alignment control screw until the output level of both channels reaches maximum.

VII. AMPLIFIER ADJUSTMENT

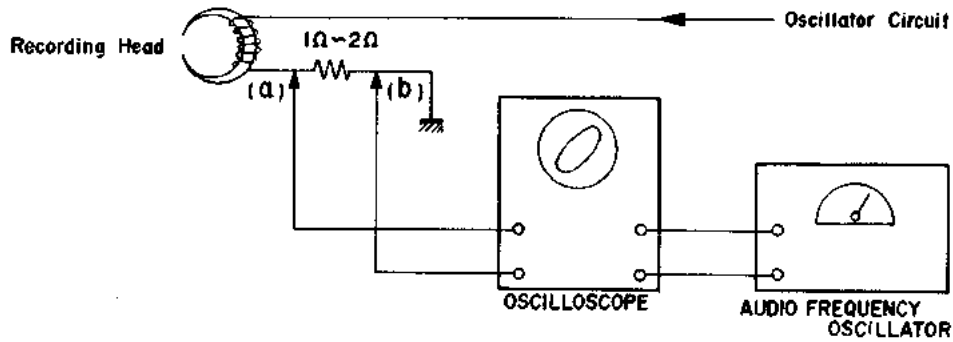

Fig. 1

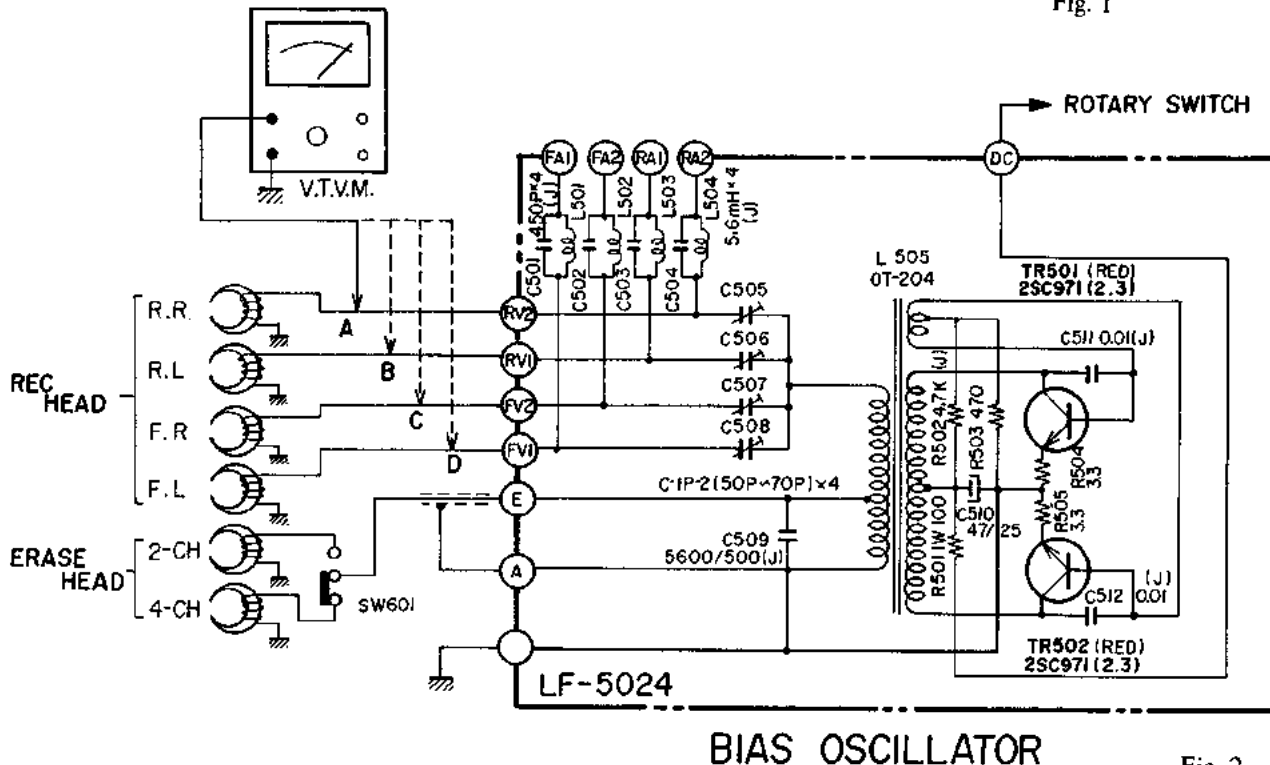

Fig. 2

1. RECORDING BIAS FREQUENCY ADJUSTMENT (Fig. 1)

- Install a resistor of 10 or 50 Ohms in series with the Recording Head and connect the Vertical Input Terminal of the Oscilloscope to points (a) and (b).
- Feed in a sine wave signal from an Audio Frequency Oscillator to the Horizontal Input of the Oscilloscope and tune the Dial of the Audio Frequency Oscillator until the Oscilloscope displays a circular or linear pattern.
- A reading of 100 KHz \pm 5 KHz (4-Ch operation), indicates that the Recording Bias Frequency is correct.
- If incorrect, it can be adjusted by inserting another condenser (C509) value 5600PF.

2. RECORDING BIAS VOLTAGE ADJUSTMENT (Fig. 2)

Connect a V.T.V.M. to point (A) to (D) and adjust the recording bias voltage by turning Variable Capacitor C505, 6, 7, 8 (50 to 70 PF) until it reads between AC 15 and 20 Volts. (The voltage of tracks 3-2 should be very slightly higher than that of tracks 1-4).

Note: There is no way of adjusting the erasing bias voltage, but the correct bias voltage is between AC 63 and 66 Volts.

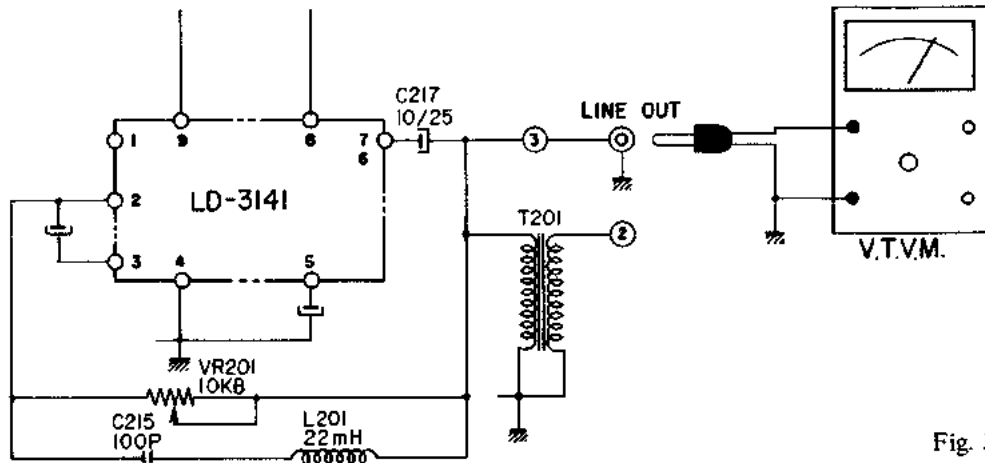

Fig. 3

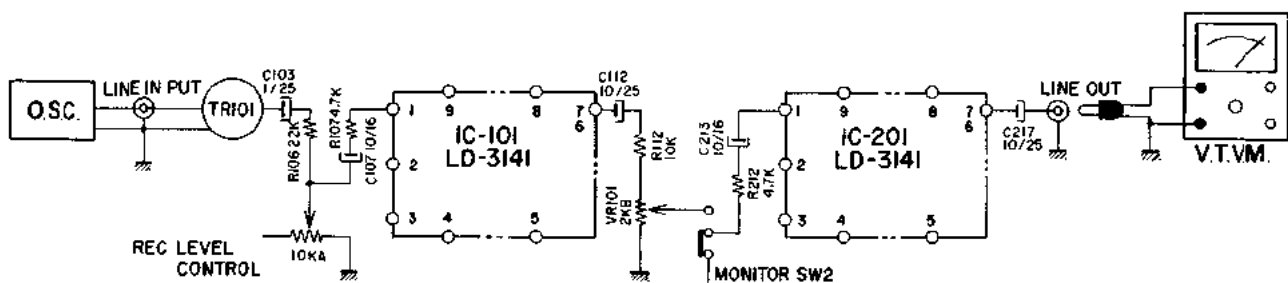

Fig. 4

3. ADJUSTMENT OF LINE OUTPUT LEVEL

1. Playback (See Fig. 3) Tape

- a. Set the Source/Tape Monitor Switch to "TAPE" position.
- b. Connect a V.T.V.M. (use one with Milli-Volt scale) to the Line Output Jack.
- c. Playback a test tape (250 Hz "0" VU recorded) at 7-1/2 ips. tape speed and turn the volume VR-201 (10 KB) until the Line Output level reaches "0" VU 1.228 V (+4 dB).

2. Recording and Playback (See Fig. 4)

- a. Connect V.T.V.M. to the Line Output Jack.
- b. Set the Source/Tape Monitor Switch to "SOURCE" position.
- c. Load a Scotch-150 blank tape and set the Record/Playback Knob to recording position.
- d. Feed in a 1,000 Hz sine wave signal from an Audio Frequency Oscillator to the Line Input of the 1730-SS and turn the Recording Level Volume Control VR1 to 4 (10 KA) until the Line Output Level reaches "0" VU 1.228 V (+4 dB).
- e. Set the Source/Tape Monitor Switch to "TAPE" position and turn the Recording Level Volume Control VR1 to 4 (10 KA) again until the Line Output Level reaches "0" VU.
- f. Set the Source/Tape Monitor Switch to "SOURCE" position again and turn the Volume Control VR-101 (2 KB) until the Line Output Level reaches "0" VU.
- g. Repeat twice in the same way as indicated in items e. and f. above.

VIII. MAINTENANCE PROCEDURE

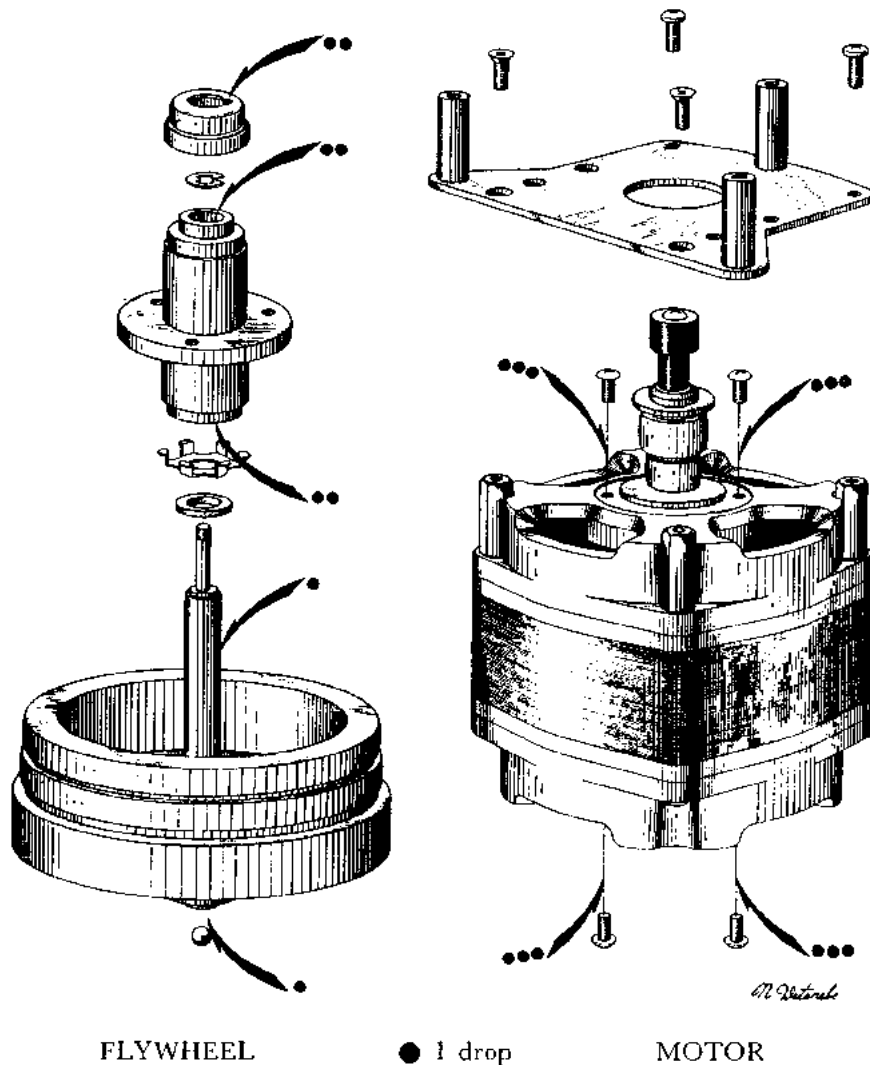

FLYWHEEL

MOTOR

1. LUBRICATION INSTRUCTIONS

For maximum service life and optimum performance, lubricate the following parts after each 500 hours of operation. Use only light machine oil of good quality.

Motor

Flywheel Assembly

Rewind Idler Wheel and Wind Take-Up Idler 1 drop

Intermediate Idler 1 drop

Pinch Wheel 1 drop

Also apply a liberal film of light machine grease to each roller surface of all levers and cams.

CAUTION: DO NOT OVER-LUBRICATE. WIPE OFF EXCESS OIL WITH A COTTON SWAB SOAKED IN ALCOHOL. OTHERWISE, EXCESS LUBRICANT MAY BE SCATTERED DURING OPERATION AND THE RUBBER COMPONENTS WILL DETERIORATE.

2. CLEANING TAPE HEADS AND OTHER PARTS

Wipe surface of tape heads, guide roller bearing, capstan bushing and pinch wheel periodically with a soft cloth soaked in alcohol.

IX. TROUBLE SHOOTING CHART

SECTION "A" TROUBLE WITH AMPLIFIER

1. Playback Problems (unit set to play position)

Symptom	Trouble
<p>No sound from Line-Out jack (No B(+) voltage supply)</p> <p>(B(+) voltage supply)</p>	<ol style="list-style-type: none"> 1. Silicon diode (10DC-1 BLK) defective 2. R402 (18 Ω 3 W) or TR401 (2SD223) defective <ol style="list-style-type: none"> 1. Check transistor TR201 and TR202 2. Check IC-201 (LD-3141) 3. Playback head coil open or lead wire loose.
<p>No sound from speaker (No B(+) voltage supply)</p> <p>(B(+) voltage supply)</p>	<ol style="list-style-type: none"> 1. Silicon diode D401 ~ 404 (VO68) defective 2. Fuse (0.7 A) defective 3. Check source/Tape monitor switch <ol style="list-style-type: none"> 1. IC-301 (STK-011) defective
<p>Sound, but volume insufficient (B(+) voltage low)</p> <p>(B(+) voltage normal)</p>	<ol style="list-style-type: none"> 1. Silicon diode D405 (10DC-1 BLK) defective 2. R402 (18 Ω 3 W) or TR401 (2SD223) defective <ol style="list-style-type: none"> 1. Dirty head 2. Check transistor (TR-201, 202) 3. Check IC-201 (LD-3141)
<p>Loud hum (Hum is decreased if playback head is grounded)</p> <p>(No change even when playback head is grounded)</p>	<ol style="list-style-type: none"> 1. Playback head shield or insulation defective <ol style="list-style-type: none"> 1. Ground wire loose 2. C401, 402 (220/50) defective
<p>Loud hum (Inductive pick-up)</p>	<ol style="list-style-type: none"> 1. Ground the recorder 2. Change the set position of the recorder
<p>Irregular scratching or crackling noise</p>	<ol style="list-style-type: none"> 1. Transistor TR 201, 202 defective 2. IC-201 (LD-3141) defective 3. Check playback card (LF-5022)
<p>Squeaking noise</p>	<ol style="list-style-type: none"> 1. Dirty head 2. Tape itself defective
<p>Hissing noise (Noise present when playing tape)</p> <p>(Not caused by tape)</p>	<ol style="list-style-type: none"> 1. Head is magnetized 2. Tape itself defective <ol style="list-style-type: none"> 1. Transistor TR-201, 202 defective
<p>Lack of treble</p>	<ol style="list-style-type: none"> 1. Poor contact between head and tape (Dirty head or back tension weak) 2. Head angle incorrect 3. Head worn-out 4. Tape itself defective
<p>Sound distorted</p>	<ol style="list-style-type: none"> 1. Dirty head 2. Defective transistor TR-201, 202 3. Head worn out

Symptom	Trouble
Considerable difference between left and right levels during playback	1. Playback level out of adjustment

2. Recording Problems (Unit plays back pre-recorded tapes satisfactorily but recording unsatisfactory).

Symptom	Trouble
Does not record (4 ch or 2 ch) (No VU meter indication) (VU meter indication normal)	1. VU meter itself or lead wire defective 2. Defective input jack 3. Transistor TR-101 defective 4. IC-101 (LD-314) defective 1. Rec/play change switch (SW 10) defective 2. Components of oscillator circuit or oscillator coil defective 3. Recording head defective
Sound distorted (VU meters function normally. Recording monitor through headphones also normal). (VU meter function normally, but recording monitor through headphones abnormal)	1. Faulty recording bias circuit 2. Faulty recording equalization circuit 3. Dirty head 1. Over-recording input 2. Defective input equipment 3. Check recording amp card (LF-5023)
Faulty erasing (4 ch or 2 ch) (Does not erase at all) (Incomplete erasure)	1. Erase head defective 2. Disconnected erase head wire. Excessive amount of dust adhering to head surface 1. Erasing bias voltage low (TR-501, 502 ; oscillator coil or Erase Head defective)
Erasing noise (Popping noise)	1. Defective recording tape 2. Transistor TR-501, 502 defective 3. Head magnetized
Recording sensitivity low (VU meter functions normally) (UV meter does not indicate properly)	1. Dirty head 2. Bias voltage out of adjustment 3. Transistor TR-501, 502 defective 4. Tape itself defective 1. Loose input jack connection 2. VU meter sensitivity low 3. Recording level out of adjustment
Sound fades or drops out	1. Dust adhering to the head surface 2. Tape itself dirty 3. Back tension too weak 4. Recording bias voltage too low 5. Head worn
Considerable difference between left and right levels when recording	1. Large deviation from line VR (RV1 ~ 4) curve 2. Recording level out of adjustment

SECTION "B" TAPE TRANSPORT MECHANISM TROUBLES

Symptom	Trouble
<p>Capstan does not rotate (Trouble with motor)</p> <p>(Trouble with power transmission mechanism)</p>	<ol style="list-style-type: none"> 1. Broken field coil 2. Defective motor starting capacitor (C2) 3. Rotor shaft dragging due to lack of oil 4. Foreign matter between rotor and stator <ol style="list-style-type: none"> 1. Broken capstan drive belt 2. Capstan drive belt off of driving position 3. Motor bushing slipping on motor shaft 4. Oil adhering to motor bushing and/or flywheel
<p>Capstan rotates in stop position, but tape does not advance when switched to play position. (Trouble with motor)</p> <p>Trouble with power transmission mechanism</p>	<ol style="list-style-type: none"> 1. Decreased motor torque 2. Defective C2 3. Motor bushing slipping on motor shaft <ol style="list-style-type: none"> 1. Capstan drive belt stretched 2. Oil adhering to motor bushing and/or flywheel 3. Capstan bushing slipping on flywheel shaft 4. Excessive tension in Take-up/Supply reel assembly 5. Oil adhering to capstan and/or pinch wheel 6. Insufficient pinch wheel pressure
<p>Capstan advances tape, but take-up reel does not take up tape</p>	<ol style="list-style-type: none"> 1. Reel shaft dragging due to Lack of oil 2. Take-up idler wheel does not operate properly 3. Oil adhering to idler wheel and roller on take-up reel shaft assembly 4. Take-up idler wheel poor contact
<p>Take-up function normal, but tape speed slower than regular speed (Trouble with motor)</p> <p>(Fluctuation in power supply)</p> <p>(Trouble with power transmission mechanism)</p>	<ol style="list-style-type: none"> 1. Rotor shaft dragging due to lack of oil or defective motor starting capacitor (C2) <ol style="list-style-type: none"> 1. Check line voltage and cycle use voltage regulator if line voltage is lower than standard <ol style="list-style-type: none"> 1. Capstan drive belt stretched and slipping on motor bushing 2. Capstan drive belt not in correct driving position 3. Oil adhering to motor bushing and/or flywheel
<p>Wow/Flutter (Irregular tape movement) (Trouble with motor)</p> <p>(Trouble with power transmission mechanism)</p>	<ol style="list-style-type: none"> 1. Decreased motor torque 2. Defective motor starting capacitor (C2) <ol style="list-style-type: none"> 1. Take-up, supply reel shaft dragging or excessive tension 2. Capstan drive belt stretched and slipping 3. Unbalanced flywheel rotation 4. Rubber on pinch wheel deteriorated 5. Pinch wheel or tape guide does not rotate smoothly 6. Dirty head surfaces 7. Insufficient pinch wheel pressure 8. Capstan bushing slipping on flywheel shaft 9. Worn-out idler wheel or no oil

Symptom	Trouble
Unit does not operate in Fast Forward mode (Take-up reel shaft does not rotate even before placing recording tape on unit)	<ol style="list-style-type: none"> 1. Oil adhering to take-up idler wheel or motor bushing 2. Loose motor bushing 3. Take-up idler wheel does not function properly 4. Take-up reel shaft assembly does not function properly 5. Check lever G
Take-up reel shaft does not rotate when recording tape is placed on unit	<ol style="list-style-type: none"> 1. Decreased motor torque 2. Defective motor starting capacitor C2 3. Excessive slippage of clutch material (felt) in take-up reel shaft assembly 4. Tape guide roller does not rotate smoothly 5. Take-up reel warped and touching deck top panel
Unit does not rewind tape (Supply (rewind) reel shaft does not rotate even before placing recording tape on unit) (Supply rewind) reel shaft does not rotate when tape is placed on unit)	<ol style="list-style-type: none"> 1. Oil adhering to rewind idler or motor bushing 2. Intermediate idler (back bakelite wheel) not working correctly 3. Loose motor bushing 4. Rewind idler does not rotate or not in position 5. Supply reel shaft assembly does not rotate smoothly <ol style="list-style-type: none"> 1. Decreased motor torque 2. Defective motor starting capacitor (C2) 3. Excessive slippage of clutch material (felt) in supply reel shaft assembly 4. Tape guide roller does not rotate 5. Supply (rewind) reel warped and touching deck top panel
Loose tape winding after being set to rewind or fast forward mode	<ol style="list-style-type: none"> 1. Decreased back tension of take-up and supply reel shaft assemblies
Tape spills when stopped from rewind or fast forward mode	<ol style="list-style-type: none"> 1. Excessive slippage of felt clutch material in take-up and rewind reel shaft assemblies 2. Reels of different sizes are used for example "5" reel on take-up side and "7" reel on supply side
Brake does not function properly	<ol style="list-style-type: none"> 1. Worn-out brake shoes 2. Oil adhering to surface of brake shoes 3. Loose brake shoes 4. Brake lever does not function properly
Periodical clacking noise when rewinding or fast forwarding tape	<ol style="list-style-type: none"> 1. Worn-out and rugged idler wheel
Loud motor vibration	<ol style="list-style-type: none"> 1. Loose motor mounting screw 2. Defective motor starting capacitor (C2) 3. Oil cover mounting screw loose
Squeaking noise when playing tape	<ol style="list-style-type: none"> 1. Deposit of dust on heads 2. Recording tape is being charged with static electricity 3. Excessive heat on head surface after continued operation 4. Oil and worn-out recording tape 5. Inferior recording tape
Automatic stopping device does not function	<ol style="list-style-type: none"> 1. Shut off switch (SW 8, 9) does not work properly 2. Automatic stop lever does not move or is sticky <ol style="list-style-type: none"> a. Broken lever spring or lever spring not in position b. Automatic stop lever sticks to rear deck panel

Symptom	Trouble
Cycle change switch does not move	<ol style="list-style-type: none">1. No lubricant on cycle conversion lever2. Eccentric or bent cycle conversion lever3. Capstan drive belt not driving track of flywheel4. Loose motor bushing5. Loose motor mount screw6. Oil on motor bushing or on flywheel

X. COMPOSITE VIEWS OF COMPONENTS

1. PLAYBACK AMP. P.C. BOARD (LF-5022)

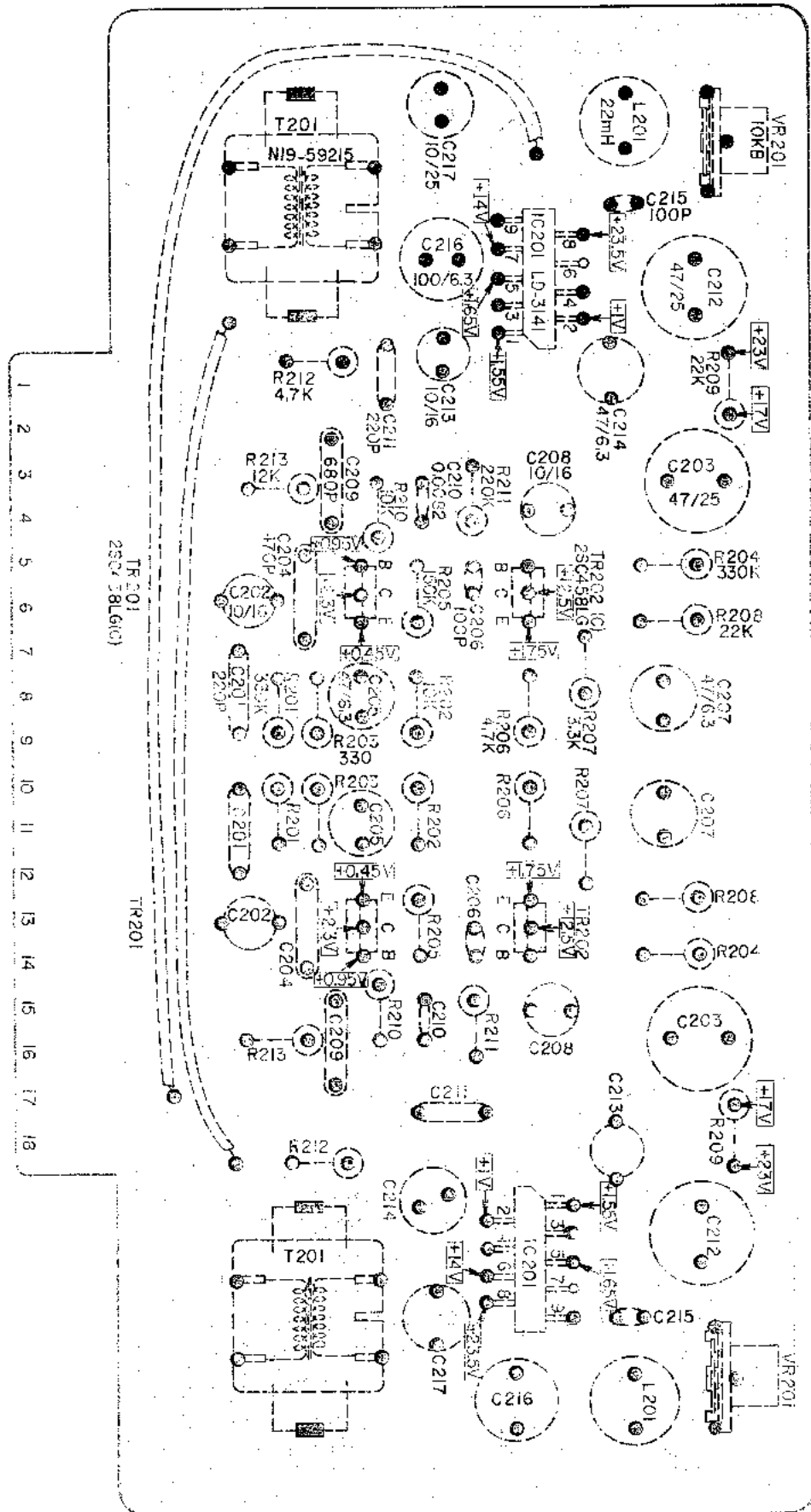

2. RECORDING AMP. P.C. BOARD (LF-5023)

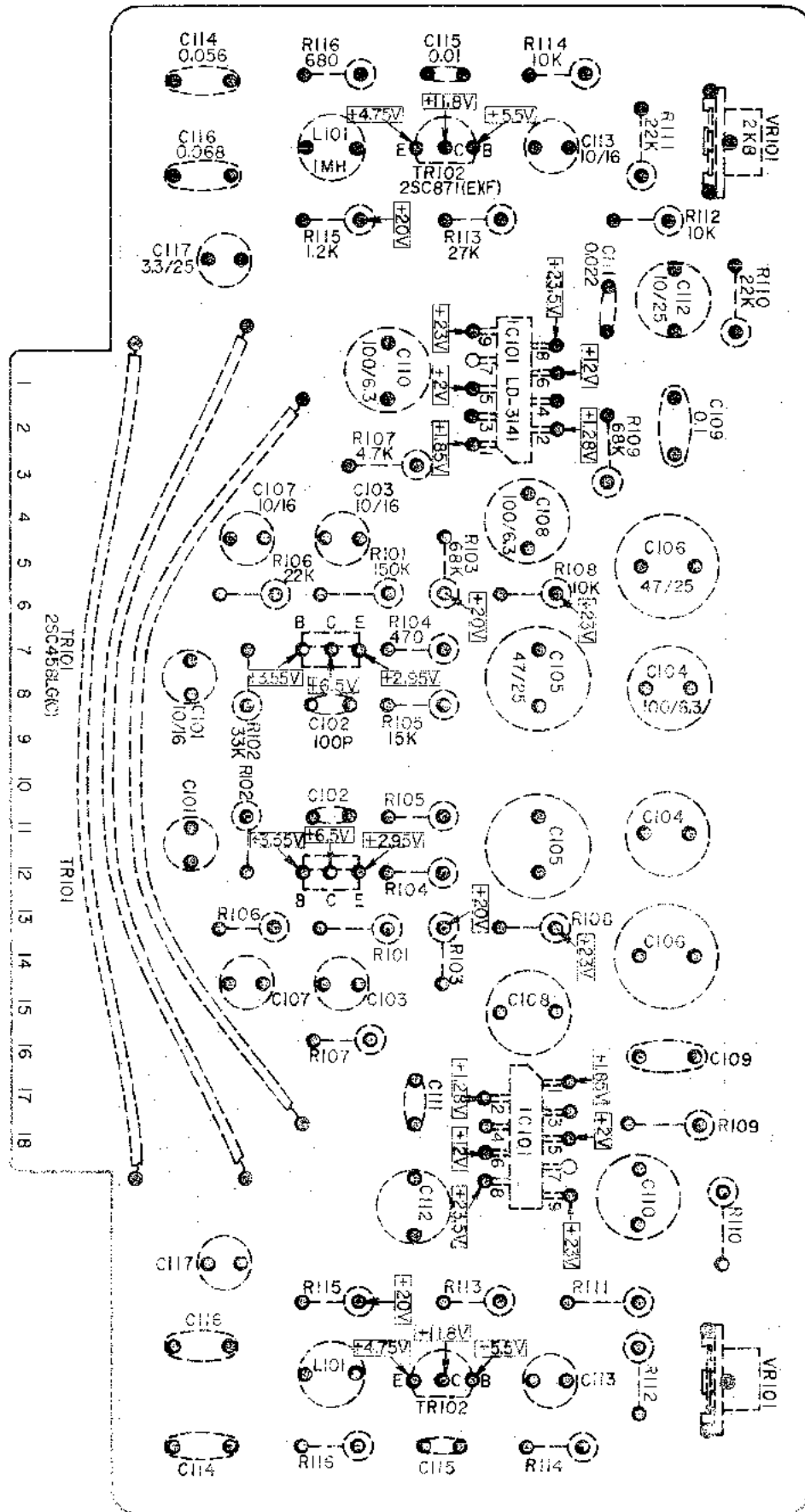

3. MAIN AMP. P.C. BOARD (LD-544)

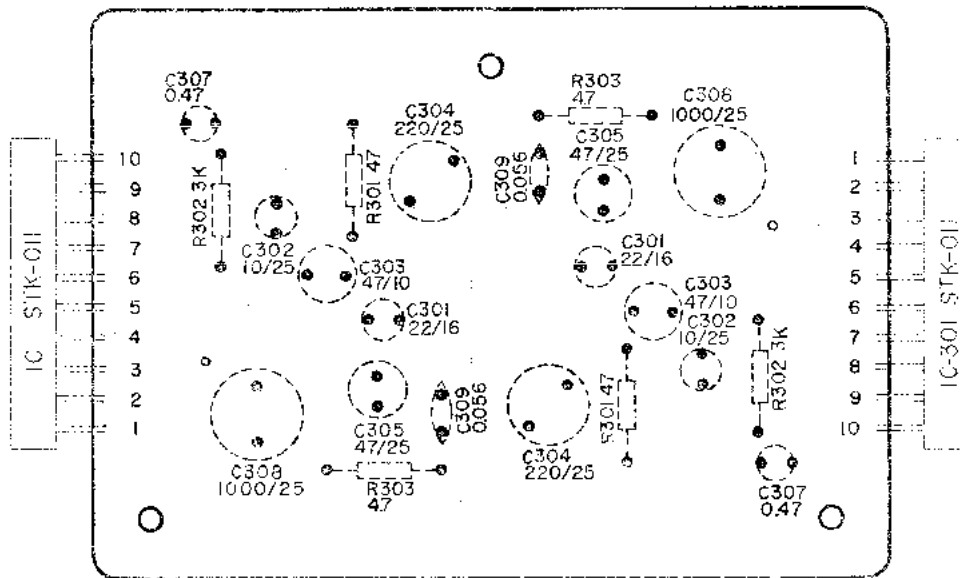

4. OSCILLATOR P.C. BOARD (LF-5024)

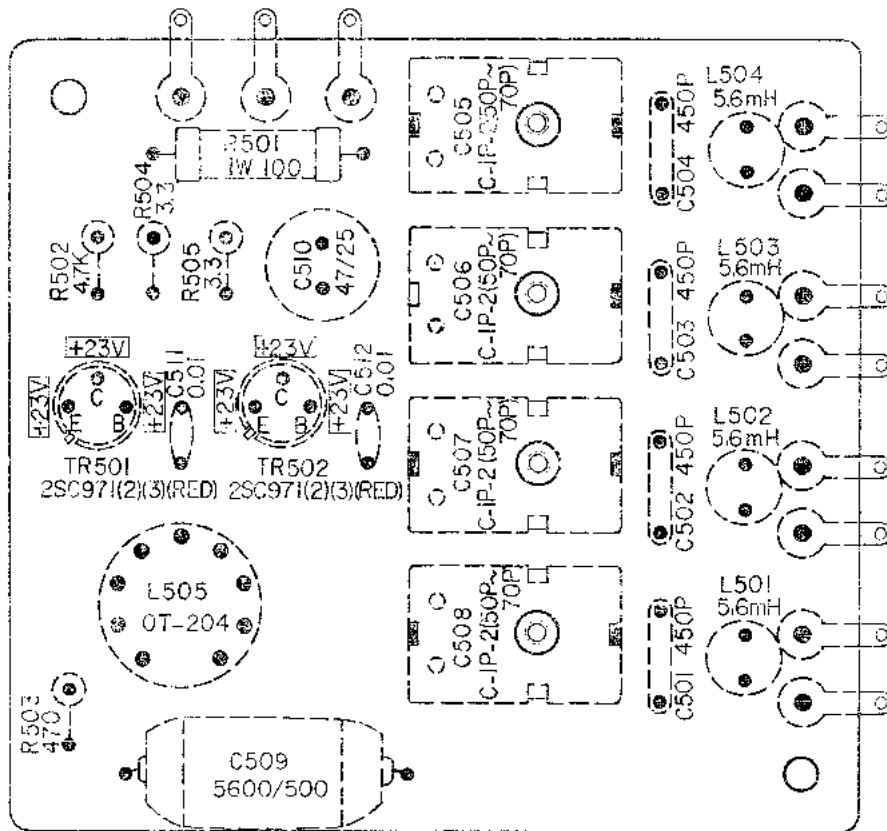

5. STEREO CHANGING SW. P.C. BOARD (LF-5025)

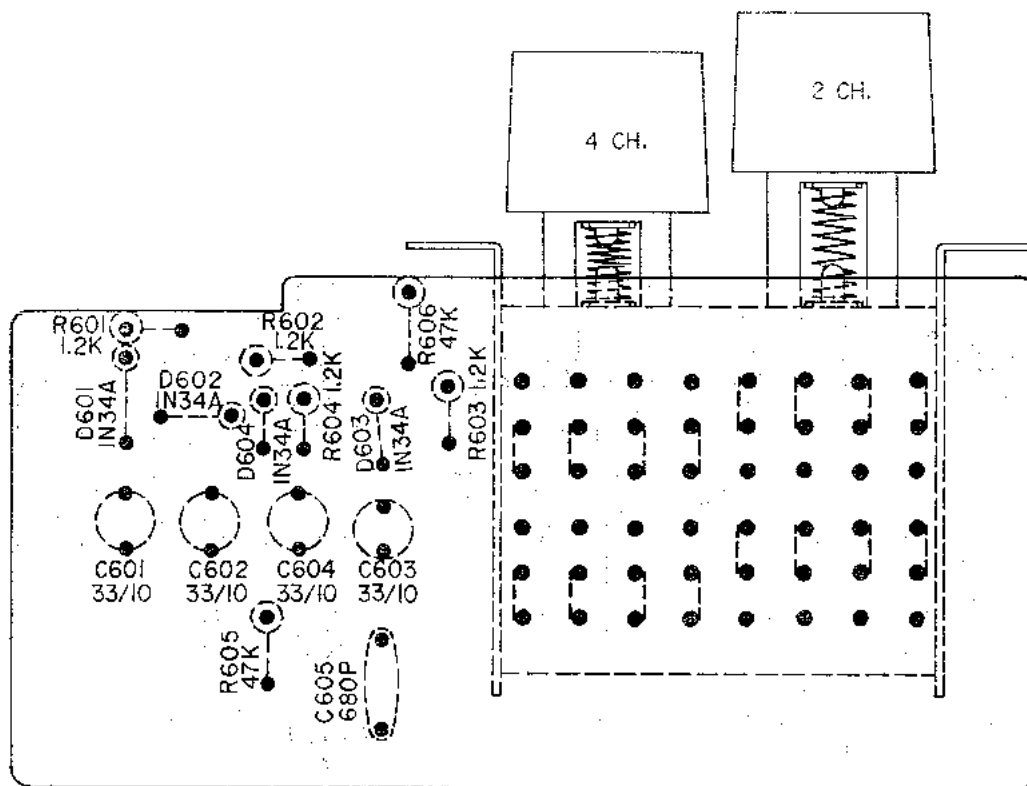

6. POWER SOURCE P.C. BOARD (LF-5026)

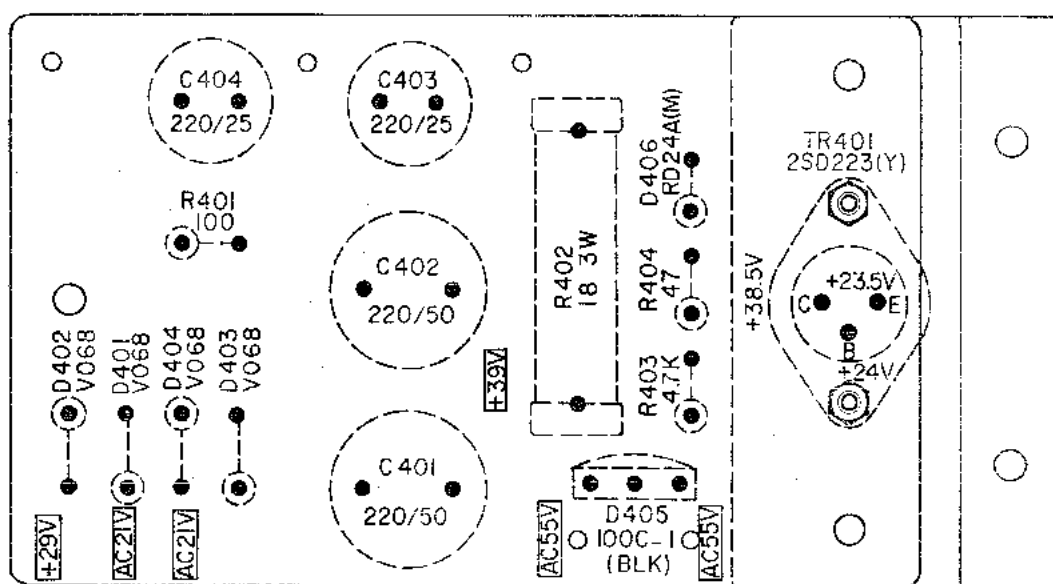

1730SS, 1730DSS.

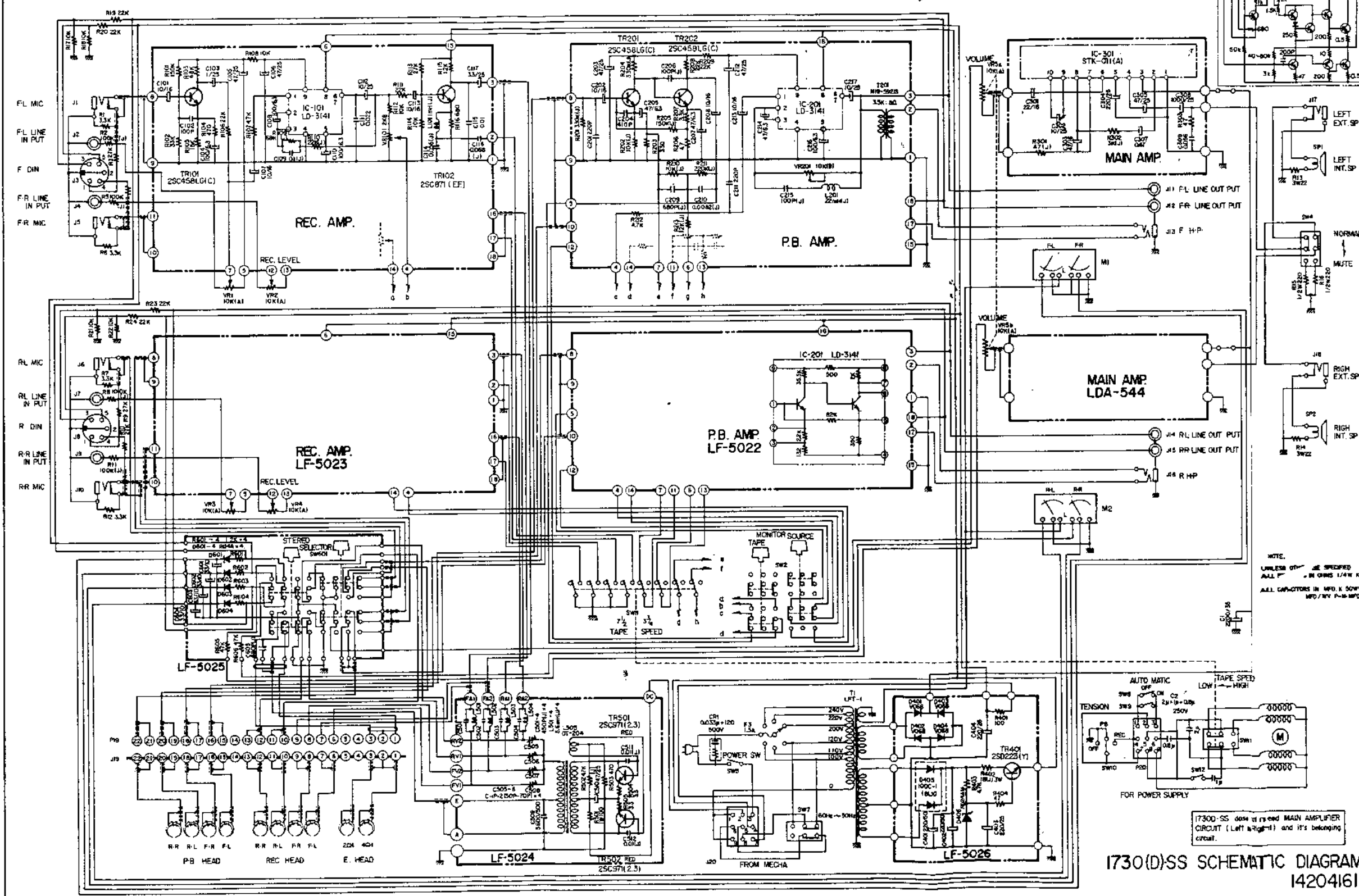

1730(D)SS SCHEMATIC DIAGRAM 1420461



AKAI

AKAI ELECTRIC CO., LTD.
AKAI TRADING CO., LTD.

12-14, 2-chome, Higashi-Kojima,
Ohta-ku, Tokyo, Japan

Price \$4.00

Printed in Japan