



## TABLE OF CONTENTS

I	SPECIFICATIONS .....	2
II	MEASURING METHODS .....	3
III	CONTROL LOCATIONS .....	5
IV	DISMANTLING OF TAPE TRANSPORT UNIT & AMPLIFIERS .....	6
V	TRANSPORT MECHANISM .....	8
VI	MECHANISM ADJUSTMENT .....	11
VII	AMPLIFIER ADJUSTMENT .....	13
VIII	MAINTENANCE PROCEDURES .....	14
IX	COMPOSITE VIEWS OF COMPONENTS .....	15
X	TROUBLE SHOOTING CHART .....	17
XI	SCHEMATIC DIAGRAM	

When placing order for parts, please use Separate  
PARTS LIST or PRICE LIST FOR PARTS.

## I. SPECIFICATIONS

WEIGHT	: 29.5 lbs. (13.4 kg)	MOTOR	: Two-speed induction motor
DIMENSIONS	: 14.4" (H) x 14.2" (W) x 9.6" (D) (H360 x W355 x D240 mm)	Revolutions	: 2,900 to 1,450 r.p.m. at 50 Hz 3,480 to 1,740 r.p.m. at 60 Hz
POWER SUPPLY	: 100 to 240 V AC, 50/60 Hz	HEADS	
RECORDING		REC/PLAY	
SYSTEM	: In-line 4-track stereo, monaural recording	HEAD	: In-line 4-track stereo/monaural
PLAYBACK		Gap	: . . . . . 4/1000 mm
SYSTEM	: In-line 4-track stereo, monaural play back	Impedance	: . . . . . 3,600 ohms at 1,000 Hz
POWER		ERASE HEAD	: In-line 4-track stereo
CONSUMPTION	: 50 W	Gap	: . . . . . 0.1 mm
TAPE SPEED	: 1-7/8, 3-3/4, 7-1/2 ips. (15 ips with 15" adaptor kit)	Impedance	: . . . . . 3,600 ohms at 90 kHz
TAPE SPEED		RECORD LEVEL	
DEVIATION	: Within $\pm 3\%$ at all speeds.	INDICATOR	: Vertical indicating model "A" VU meter
WOW AND		TRANSISTORS	: 2SC693U (F) x 4 2SC870 (E or D) x 2 2SC711 (E or D) x 2 2SC1013 (C, D) x 4 2SC971 (2, 3) x 2
FLUTTER	: Less than 0.18% R.M.S. at 7-1/2" Less than 0.25% R.M.S. at 3-3/4" Less than 0.35% R.M.S. at 1-7/8"	DIODES	: 10DC-1 (Red) x 2 10DC-1 (Blk) x 2 1N34A x 2
FREQUENCY		REELS	: 7" 5" reels can be used.
RESPONSE	: 40 to 15,000 Hz $\pm 4$ dB at 7-1/2" 40 to 10,000 Hz $\pm 4$ dB at 3-3/4" 40 to 4,000 Hz $\pm 4$ dB at 1-7/8"		
SIGNAL TO			
NOISE RATIO	: More than 48 dB		
DISTORTION			
(Total Harmonics)	: Within 3% at 1,000 Hz 0 VU recording		
CROSS-TALK	: Less than -55 dB (monaural) Less than -43 dB (Stereo)		
ERASE RATIO	: Less than -65 dB		
INSULATION			
RESISTANCE	: More than 50 M ohms.		
INSULATION			
DURABILITY	: 1,000 V AC for more than one minute duration		
LINE OUTPUT	: +4 dB $\pm 2$ dB (1.228 V), at 0 VU indi- cation, 250 Hz 0 VU recorded tape. Required load impedance more than 50 K ohms.		
POWER OUTPUT	: More than 2 W Impedance : 8 ohms		
PHONO OUTPUT	: 2.5 V at maximum volume Required load impedance more than 50 K ohms.		
LINE INPUT	: Above 30 mV Impedance : 140 K ohms		
MIC. INPUT	: Above 3.5 mV Impedance : 30 K ohms		
PHONO INPUT	: Above 10 mV Impedance : 43 K ohms		
FAST FORWARD AND REWIND			
TIME	: 150 seconds for 1,200 ft. tape at 50 Hz 120 seconds for 1,200 ft. tape at 60 Hz		
MONITOR			
SYSTEM	: Program can be monitored during recording by using stereo headphones.		

## II. MEASURING METHODS

### TAPE SPEED DEVIATION

#### 1. Pre-recorded tape measuring method

Playback on the tape recorder being tested, a tape pre-recorded at 1,000 Hz  $\pm 0.1\%$ .

Connect the appropriate output to a frequency count meter in order to measure any deviation from the pre-recorded tape.

#### 2. Timing tape measuring method

(designed for tape speed measurement)

This method utilizes a timing tape marked at intervals of 7-1/2". Playing time over 60 marked sections is measured in order to calculate tape speed deviation. In using this method, however, it should be kept in mind that timing tape stretch or contract error is inevitable, so that it is necessary to measure the total length of the tape in advance.

### WOW AND FLUTTER

Playback a 3,000 Hz pre-recorded tape, of which the wow and flutter level is guaranteed to be smaller than 0.07%, and measure with a wow meter. It is also possible for a 3,000 Hz sine wave to be recorded and played back for measurement with a wow meter. In this case, however, the wow meter will indicate a value as much as twice that given in the specifications.

### SIGNAL TO NOISE RATIO



Set the Equalizer Switch to the "7-1/2 ips" position and playback a tape containing a 250 Hz sine wave recorded at "0" VU level on any standard recorder. Connect a V.T.V.M. to the line output jack of the recorder and measure its output. Next, remove the tape and measure the noise level under the same conditions. Convert each of the measured values into decibels.

### TOTAL HARMONIC DISTORTION FACTOR



Connect the measuring instruments as shown above, and record a 1,000 Hz sine wave at "0" VU. Playback the resultant signal and measure the overall distortion factor. Measure the noise level of the tape recorder with the tape removed; connect the audio oscillator directly to the distortion meter for measurement of the distortion factor of the oscillator.

The resultant distortion factor can be obtained from the results of the above measurement by using the following formula.

$$d_0 = d - d_1 - d_2$$

where,  $d_0$  = Required  
 $d$  = Overall distortion factor  
 $d_1$  = Noise level  
 $d_2$  = Distortion factor of the oscillator

(Note: New tape of particularly good quality should be used for measurement of the distortion factor).

### POWER OUTPUT

Playback a tape containing a sine wave of 250 Hz recorded at "0" VU on any standard recorder.

Connect a V.T.V.M. to the line output jack of the recorder and measure the voltage at the output of the recorder being tested.

## CROSS TALK (Cross talk between the tracks)



As shown in the figure, first record a 1,000 Hz sine wave on track No. 3 at +3 VU level. Next, remove the 1,000 Hz input signal and record under a non-input condition. Then, playback the tape on tracks 3 and 1 (reversed condition of tape) through the 1,000 Hz B.P.F. (Band Pass Filter, Sensitivity . . . 1 : 1) and obtain the ratio between the two by using the following formula.

$$C = 20 \log \frac{E_0}{E_2 - E_1} \text{ (db)}$$

C = Desired cross talk ratio (db)

$E_0$  = 1,000 Hz signal output level

$E_2$  = 1,000 Hz cross talk output level

$E_1$  = Non-input signal record level



## PLAYBACK :

- 5) Set the Record/Playback Lever to "Play" position.
- 6) Connect a V.T.V.M. to the Line Output.
- 7) Playback the previously recorded tape.
- 8) Adjust the output level to "0" dBm at 1,000 Hz (indicated on range selector of V.T.V.M.).
- 9) Playback the recorded spot frequencies under the conditions in (8) ; make a memo of Output Level and plot the value on a graph.

## FREQUENCY RESPONSE

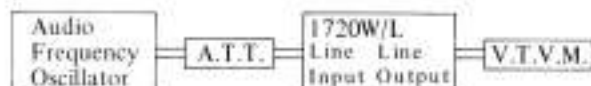

Connect the measuring instruments as shown in the above diagram, and measure the frequency response in the following sequence :

### RECORD :

- 1) Introduce a sine wave of 1,000 Hz to the Line Input of the recorder being tested through an attenuator from an audio frequency generator.
- 2) Set the Record/Playback Lever to "Rec" position and adjust the line input volume so that the VU meter needle indicates "0" VU.
- 3) Under the conditions described in (2), lower the input level 16 dB with the attenuator.
- 4) Record the spot frequency from the audio frequency generator in the range of 40 to 15,000 Hz.

### III. CONTROL LOCATIONS



Fig. 1

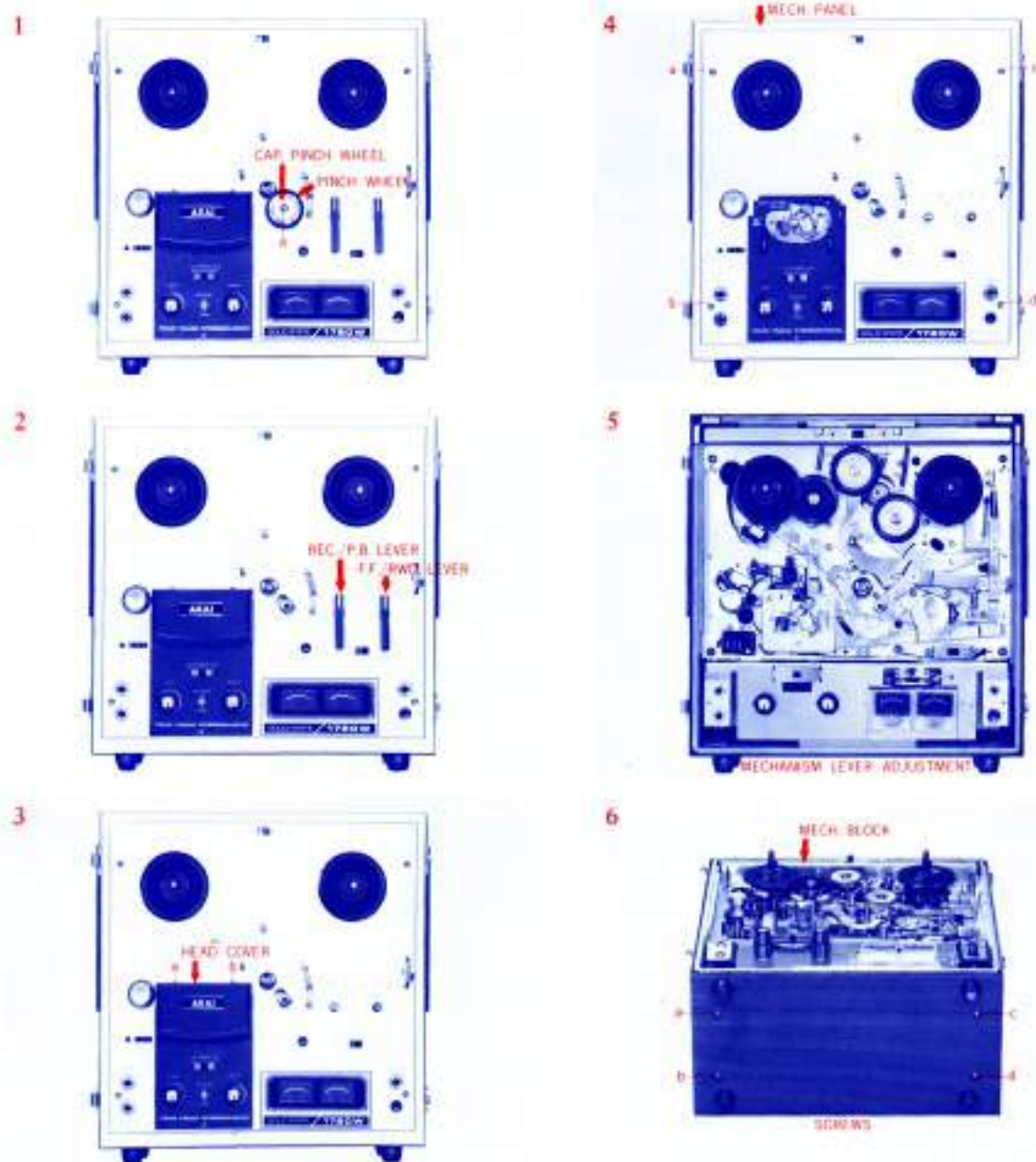

Fig. 2

## IV. DISMANTLING OF TAPE TRANSPORT UNIT & AMPLIFIERS

---

In case of trouble, etc. necessitating disassembly, please disassemble in the order shown in photographs. Reassemble in reverse order.



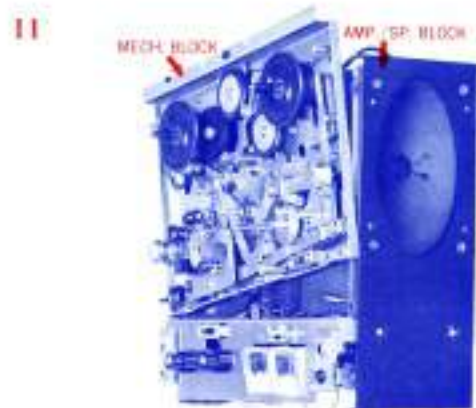

## V. TRANSPORT MECHANISM

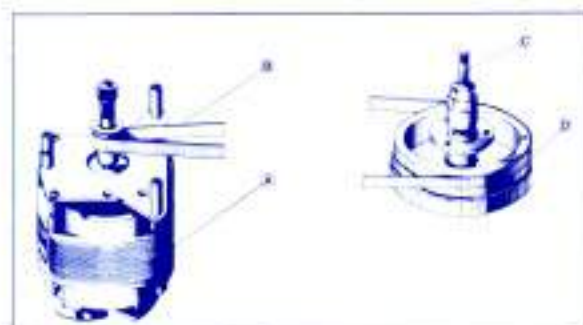

Fig. 1

### 1. CAPSTAN DRIVE

Figure 1.

- (A) Motor
- (B) Drive Belt (flat belt)
- (C) Capstan
- (D) Flywheel

High-speed rotation of Motor (A) is transmitted by Drive Belt (B) to Capstan (C); which is connected to a flywheel that provides necessary inertia. This flywheel maintains the rated rotation and absorbs minor rotation variations of the motor.

Capstan Rotation :

- 606 R.P.M. at 7-1/2" (19 cm) per sec.
- 303 R.P.M. at 3-3/4" (9.5 cm) per sec.
- 151.5 R.P.M. at 1-7/8" (4.75 cm) per sec.

Motor Rotation :

- 3,000 to 1,500 R.P.M. at 50 Hz
- 3,600 to 1,800 R.P.M. at 60 Hz

### 2. PINCH WHEEL DRIVE

The pressure of the pinch wheel as it pushes against capstan, transports tape between rotating capstan and pinch wheel at the rated speed. The proper pinch wheel pressure is between 1,000 to 1,150 grams at the tape speed of 7-1/2" (19 cm) per second.

### 3. RECORD AND PLAYBACK MECHANISM

Turning the RECORD/PLAYBACK LEVER (A) to "PLAY" position causes the pinch wheel to press against the capstan and move the tape at the rated speed. At the same time, Idler (B) moves between Motor Bushing (C) and the Take-Up Reel Spindle (D) to transmit the motor rotation to (D) so that the tape is moved and wound on the take-up reel. The Take-up Reel Spindle Base, composed of two plastic wheels (discs) (1 and 2) with a felt clutch between, is rotated from below by the idler. Tape-winding friction is adjusted by the slipping of the felt and maintains rated winding of the tape. The Supply Reel Spindle (H) has a Brake Roller (E) contacting plastic wheel (disc) (4) from below which provides appropriate back tension by the slipping of the felt clutch to the rotation of the Pulley (3) above. To prevent accidental erasure, the Record Safety Button (F) must be depressed before the RECORD/PLAYBACK LEVER can be moved to the "REC" position. Safety device (G) is depressed to operate the recording mechanism.

(See figure 2)

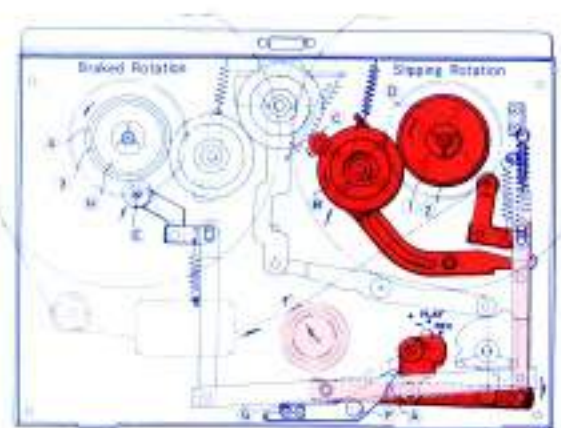

Fig. 2



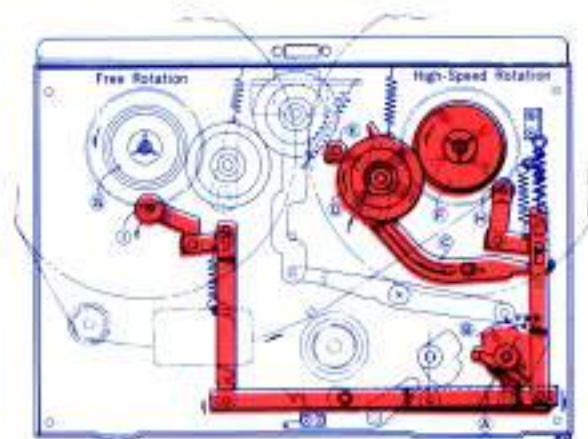

Fig. 3

#### 4. FAST-FORWARD MECHANISM

Turning the *FAST FWD-REWIND LEVER* (A) to "FAST FWD" position, causes *cam* (B) under the knob to push up *Lever* (C). *Idler* (D) moves into the space between *Plastic Roller* (F) above the *Take-Up Reel Spindle* and the upper part of the rotating *motor drive bushing* to transmit the motor rotation to the take-up reel spindle. At the same time, *Brake Rollers* (H) and (I) come off the reel spindle to free *Supply Reel Spindles* (G) and (F), thereby allowing fast winding of the tape onto the take-up reel. (See figure 3)

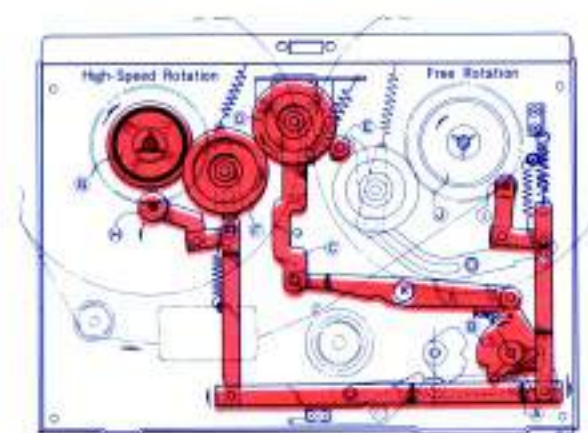

Fig. 4

#### 5. REWIND MECHANISM

Turning the *FAST FWD-REWIND knob* (A) to "REWIND" position, causes *cam* (B) under the knob to push up *Lever* (C). *Idler* (D) moves into the space between the upper part of the rotating *Motor drive bushing* (E) and the *Intermediate Pulley* (F) to transmit the high-speed rotation of the motor through the intermediate pulley to *Supply Reel Spindle* (G). At the same time, *Brake Rollers* (H) and (I) come off the reel spindle to free *take-up reel spindles* (J) and (G), thereby rewinding the tape onto the supply reel at a fast speed. (See figure 4)

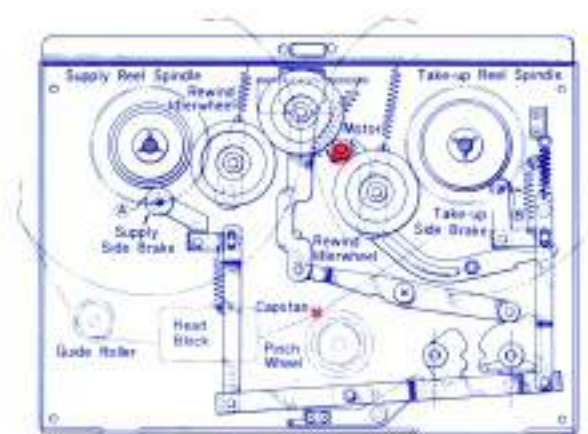

Fig. 5

#### 6. STOP CONTROL

Turning the stop lever to "STOP" position, causes *Brake Rollers* (A) and (B) to depress the reel spindles and stop rotation.

As the brake rubbers depress the plastic rollers below the reel spindles, no friction is applied to the tape. (See figure 5)

Modes of Operation	Pinch Wheel	Take-up Idler Wheel	Rewind Idler Wheel	Take-up side Brake	Supply side Brake
(a) STOP	X	X	X	—	—
(b) FAST-FORWARD	X	—	X	X	X
(c) REWIND	X	X	—	X	X
(d) RECORDING PLAYBACK	—	—	X	X	—

NOTES: X-marks indicates "open" and  
— marks "engaged"

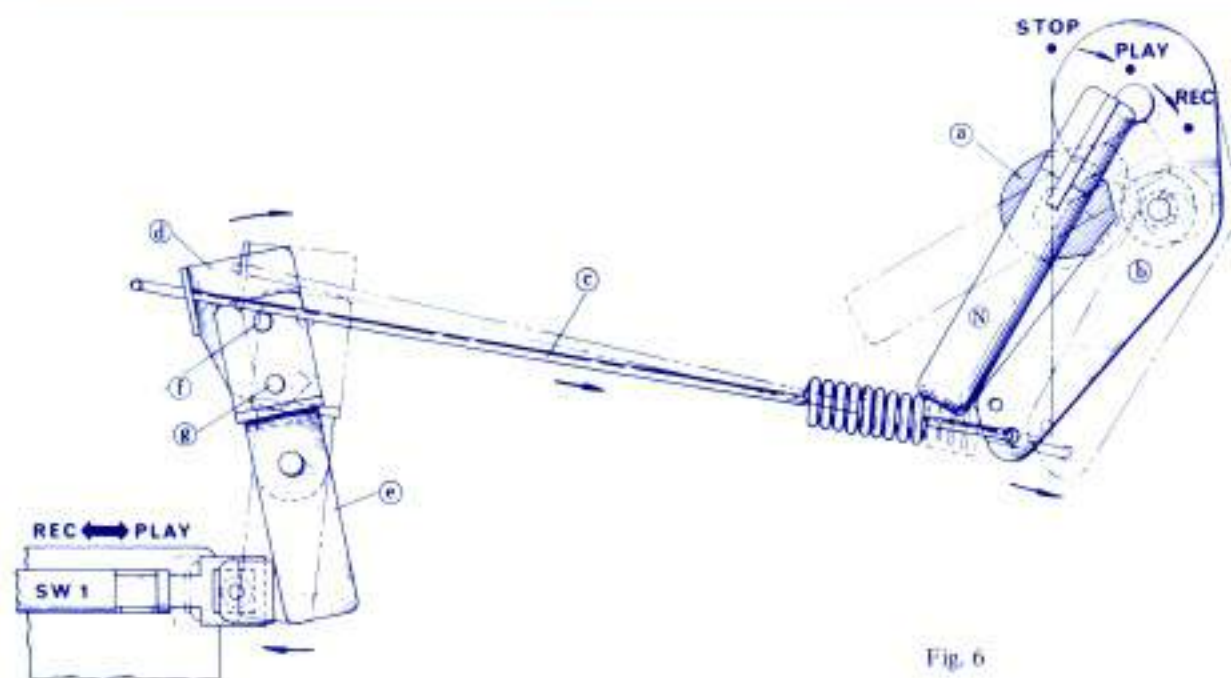

Fig. 6

#### RECORD/PLAYBACK CHANGING MECHANISM

When the RECORD/PLAYBACK LEVER (N) is turned to play position, RECORD/PLAYBACK CHANGING SWITCH (SW1) does not operate and remains fixed in play mode.

By turning the RECORD/PLAYBACK LEVER (N) to the recording position, CAM (a) pushes ARM (b), as illustrated by the dotted line. ARM (b) then pulls ARMS (d) and (e), which are joined to the RECORD/PLAYBACK CHANGING SWITCH (SW1), to the recording position.

If ARMS (b), (d) and (e) do not work properly, (SW1) does not operate properly, abnormal oscillation may occur, and recording cannot take place. The ARMS must be adjusted properly by loosening SCREWS (f) and (g).

## VI. MECHANISM ADJUSTMENT

### 1. PINCH WHEEL ADJUSTMENT

It is important that the pinch wheel shaft be kept in perfect alignment with the capstan shaft. Proper pinch wheel pressure is between 1,000 and 1,150 grams when the unit is operated at the tape speed of 7½ ips. Any deviation will result in wow and flutter. Check pinch wheel pressure with a spring scale, and if necessary, adjust the pinch wheel load spring.

### 2. TAKE-UP IDLER WHEEL ADJUSTMENT

The take-up idler wheel must be kept in perfect alignment with the take-up reel shaft. In fast forward operation, the idler wheel contacts the upper knurled wheel of the take-up reel shaft assembly, and conversely contacts the lower knurled wheel during record or play operation. Adjust idler wheel load spring so that the idler wheel pressure is kept between 50 and 80 grams. The idler wheel wears rapidly if the pressure is excessive. Slippage occurs if the pressure is less than specified.

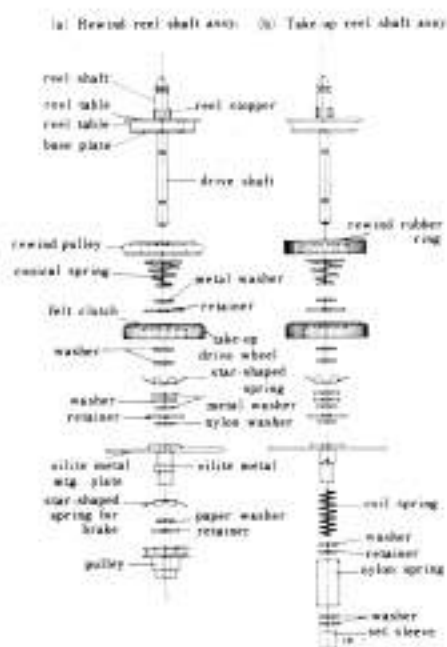

Fig. 1

### 3. REWIND IDLER WHEEL ADJUSTMENT

The rewind idler wheel must be kept in perfect alignment with the rewind reel shaft. The amount of pressure on the knurled motor bushing should be about 50 grams during rewind operation. Adjust both the idler load spring and rewind roller.

### 4. INTERMEDIATE WHEEL ADJUSTMENT

The intermediate wheel is located between the rewind idler wheel and the rubber ring which is used on the upper part of the supply reel shaft assembly. In rewind mode, it contacts these parts while simultaneously transmitting motor torque. An adequate pressure is 50 grams. Adjust the load spring of the intermediate wheel if the pressure is not sufficient.

### 5. TAKE-UP REEL SHAFT ASSEMBLY ADJUSTMENT

A felt clutch is attached to the bottom side of the reel table base plate so that recording tape will not stretch due to excessive tension during fast forward operation. To check the amount of friction on this part, install a 5-inch reel with a 60 mm diameter tape and gently pull the end of the tape upward with a spring scale. Adjust the conical spring so that the amount of tension on this part is between 350 to 450 grams. Another felt clutch is attached to the take-up drive wheel to provide proper slippage during record or play mode. The procedure for checking friction of this part is same as the foregoing, and between 150 and 200 grams of friction provides the best results. Adjust the star-shaped spring just under the take-up drive wheel. During rewind operation, the amount of friction of this part will decrease to 10 to 15 grams. Check to see whether this is satisfactory. If not, readjust the star-shaped brake spring and the pressure of the spring retainer washer accordingly.

### 6. SUPPLY REEL SHAFT ASSEMBLY ADJUSTMENT

A felt clutch is used between the lower side of the reel table base plate and the rewind rubber ring to protect the recording tape from excessive tension during recording. To check the amount of friction on this part, install a 5-inch reel with a 60 mm diameter tape, and gently pull the end of tape upward with a spring scale. Adjust the conical spring so the tension is between 350 to 450 grams. Another felt clutch is attached to the rewind drive wheel to provide proper slipping operation during record or play mode. The procedure for checking friction on this part is the same as the foregoing, and between 110 and 130 grams of friction gives best results. In fast forward operation, the amount of friction will decrease to 10 to 15 grams.

Check to see whether this is correct. If not, readjust coil spring and spring retainer washer. (See figure 1 (a) at left)

## 7. HEAD ADJUSTMENT

### (A) Adjustment of Head Height (See Fig. 2 and 3)

#### a. Erase Head

Adjust the Erase Head Height by turning head height screws (a) so that the upper edge of the tape as it passes the erase head is 0.125 to 0.15 mm below the top edge of the CH-1 erase head core.

#### b. Playback Head

Adjust the Playback Head Height by turning head height screws (b) (b') in the same manner so that the upper edge of the tape as it passes the playback head is exactly parallel with the top edge of the playback head core.

### (B) Adjustment of Vertical Azimuth of the Head

Adjust the vertical azimuth of each head (erase and playback) by turning head height screws (a) and (b) (b') until the tape comes in complete contact with each head.

### (C) Adjustment of Head Alignment

#### Playback Head

Playback an Ampex Alignment tape (8,000 Hz) at 3-3/4 ips and turn alignment control screw (c) until the output level of both channels reaches maximum.

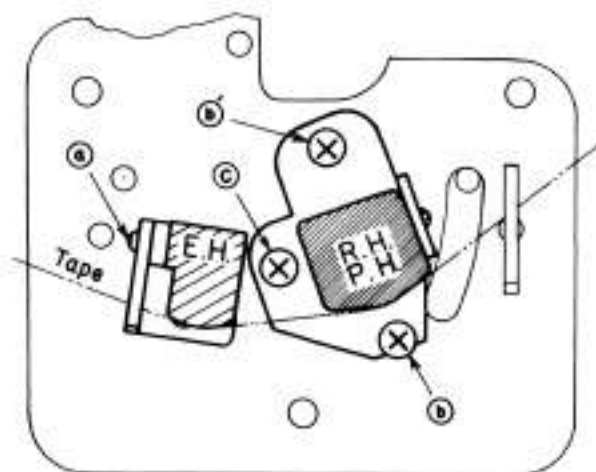

Fig. 2

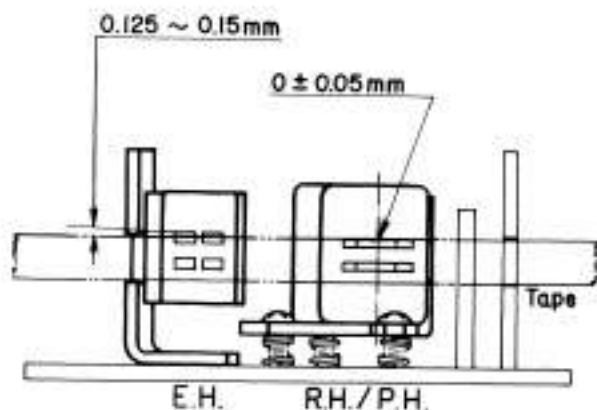

Fig. 3

## VII. AMPLIFIER ADJUSTMENT

### 1. RECORDING BIAS FREQUENCY ADJUSTMENT (Fig. 1)

- Install a resistor of 10 or 50 Ohms in series with the Bias Head and connect the Vertical Input Terminal of the Oscilloscope to points (a) and (b).
- Feed in a sine wave signal from an Audio Frequency Oscillator to the Horizontal Input of the Oscilloscope and tune the Dial of the Audio Frequency Oscillator until the Oscilloscope displays a circular or linear pattern.
- A reading of  $63 \text{ KHz} \pm 5 \text{ KHz}$ , indicates that the Recording Bias Frequency is correct.
- If incorrect, it can be adjusted by inserting another condenser (C216) value 5500PF.

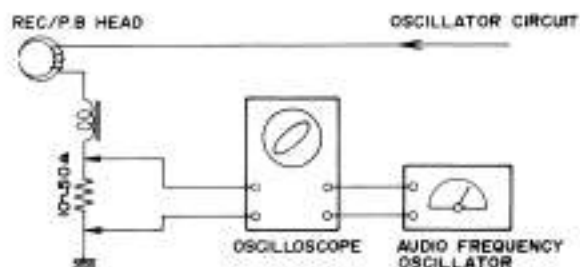

Fig. 1

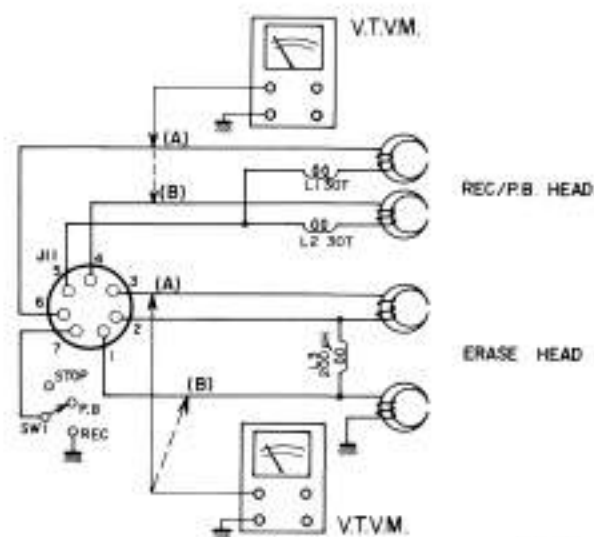

Fig. 2

### 2. RECORDING BIAS VOLTAGE (Fig. 2)

- Connect the V.T.V.M. to points (A) and (B), then read the value on the V.T.V.M.
- A reading of  $\text{AC } 35 \text{ V} \pm 2 \text{ V}$ , indicates that the Recording Bias Voltage is correct.

### 3. ERASING BIAS VOLTAGE (Fig. 2)

- Connect the V.T.V.M. to points (A) and (B), then read the value on the V.T.V.M.
- A reading of  $\text{AC } 22 \text{ to } 30 \text{ V}$ , indicates that the Erasing Bias Voltage is correct.

## VIII. MAINTENANCE PROCEDURES

---

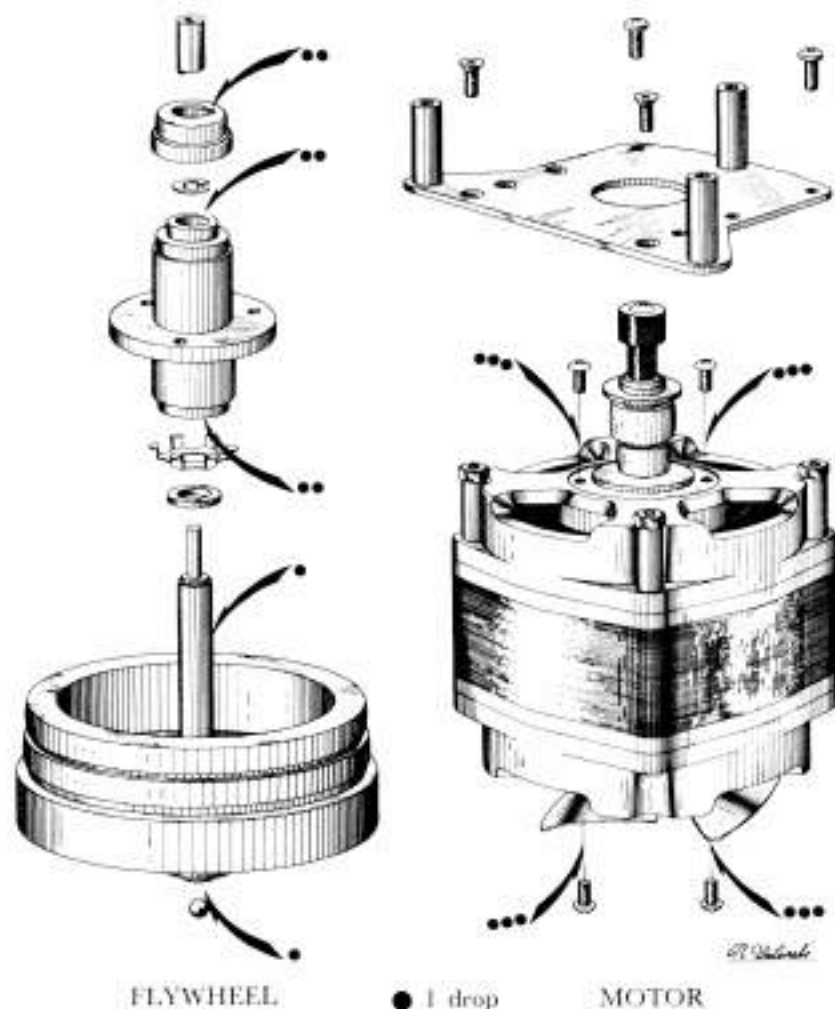

### 1. LUBRICATION INSTRUCTIONS

For maximum service life and optimum performance, lubricate the following parts after each 500 hours of operation. Use only light machine oil of good quality.

Motor

Flywheel Assembly

Rewind Idler Wheel and Wind Take-Up Idler 1 drop

Intermediate Idler 1 drop

Pinch Wheel 1 drop

Also apply a liberal film of light machine grease to each roller surface of all levers and cams.

**CAUTION : DO NOT OVER-LUBRICATE. WIPE OFF EXCESS OIL WITH A COTTON SWAB SOAKED IN ALCOHOL. OTHERWISE EXCESS LUBRICANT MAY BE SCATTERED DURING OPERATION AND THE RUBBER COMPONENTS WILL DETERIORATE.**

### 2. CLEANING TAPE HEADS AND OTHER PARTS

Wipe surface of tape heads, guide roller bearing, capstan bushing and pinch wheel periodically with a soft cloth soaked in alcohol.

## IX. COMPOSITE VIEWS OF COMPONENTS

### PRE-AMPLIFIER P.C. BOARD (LS-5014)

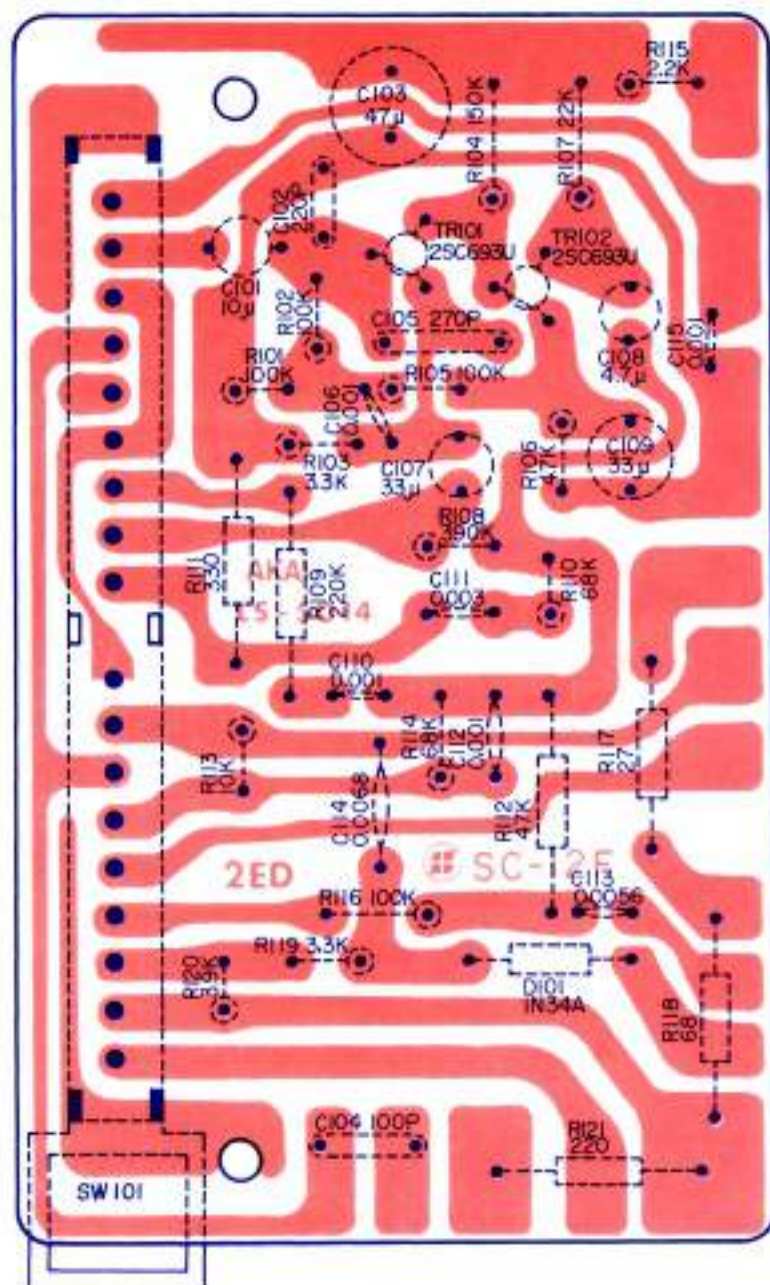

MAIN AMPLIFIER P.C. BOARD (LS-5015)

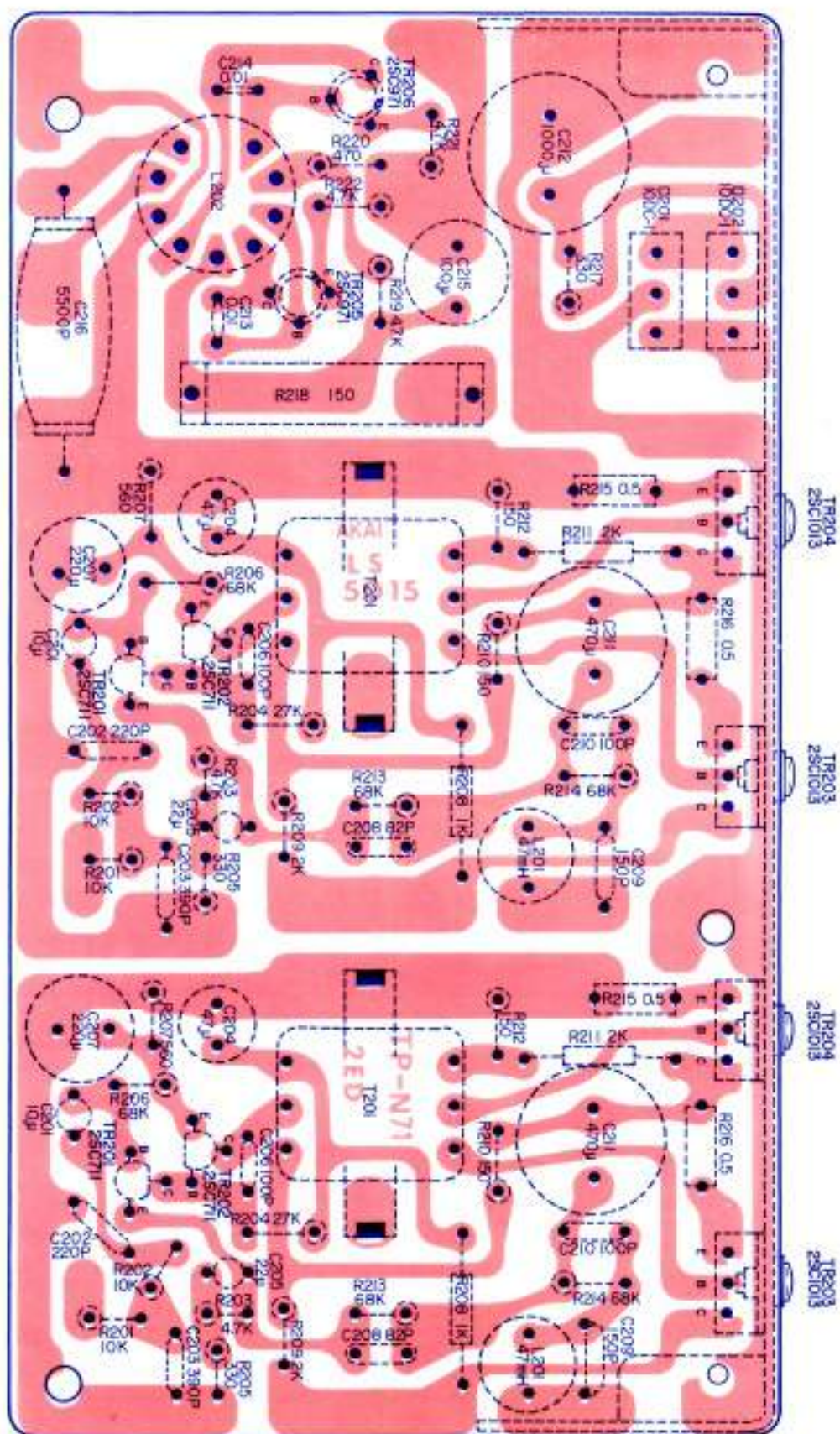



# X. TROUBLE SHOOTING CHART

## SECTION "A" TROUBLES WITH AMPLIFIER

### 1. Playback problems. (Unit set to play position.)

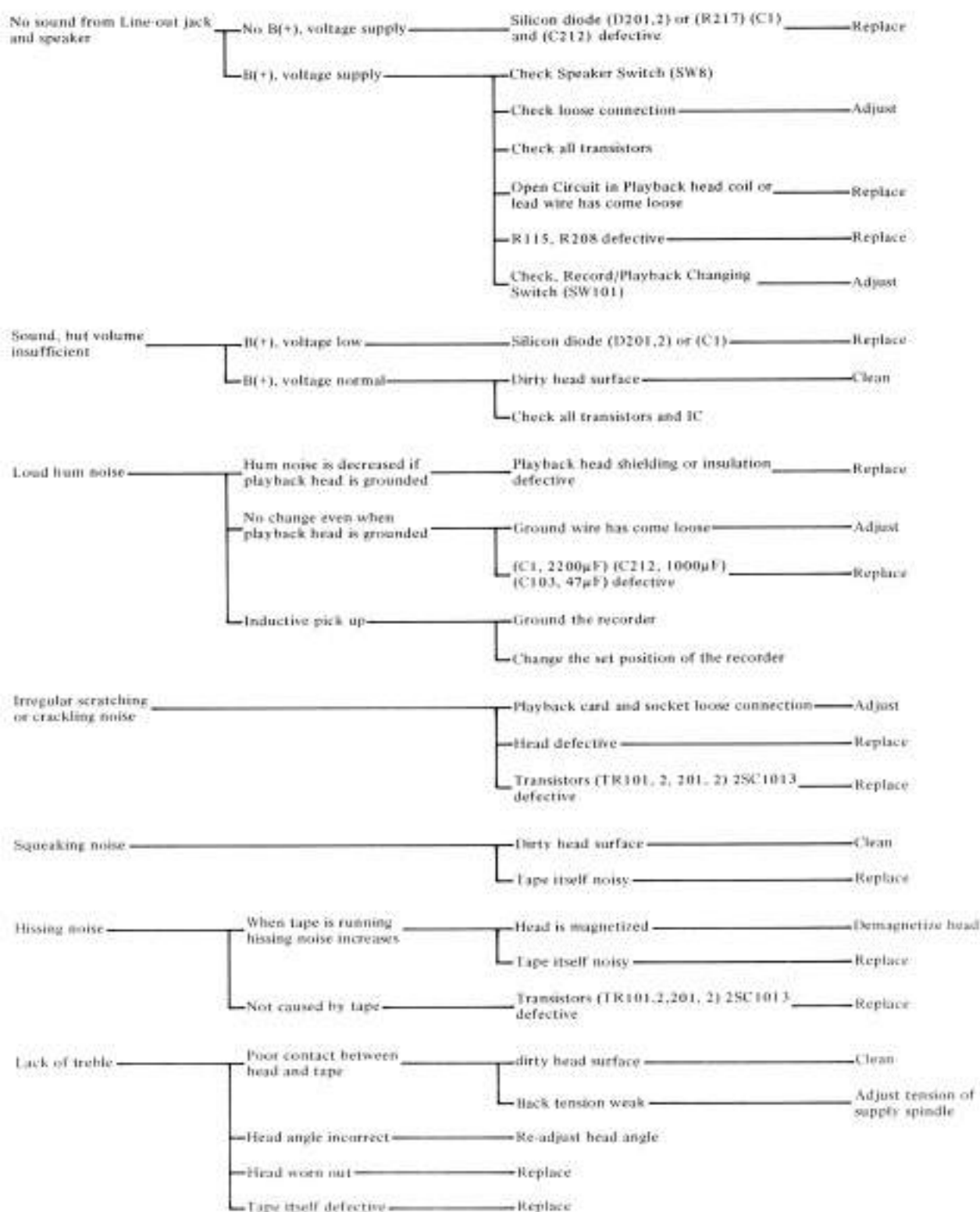

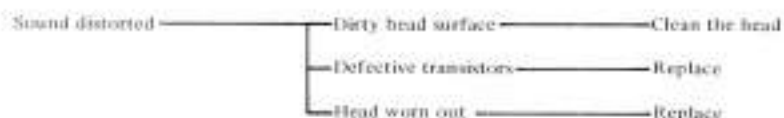

**2. Recording problems.**  
 (Unit plays back pre-recorded tape satisfactorily, but recording unsatisfactory.)



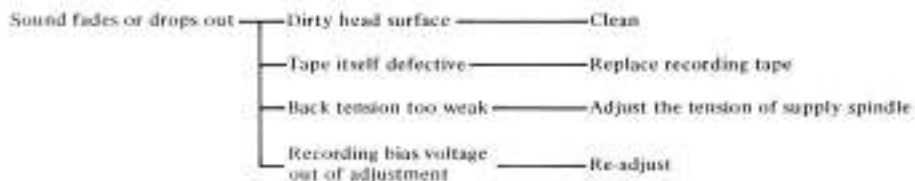
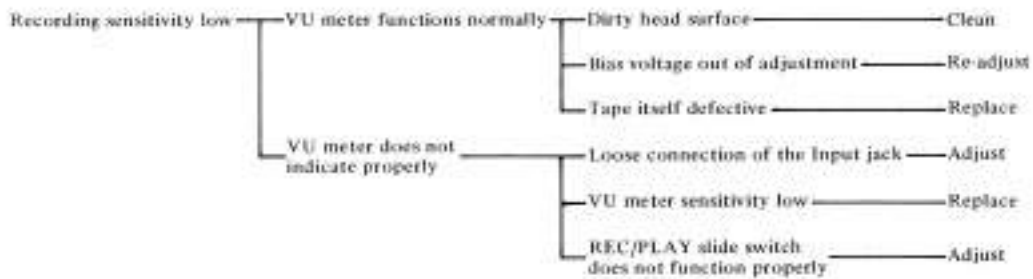

## SECTION "B" TROUBLES WITH TAPE TRANSPORT MECHANISM



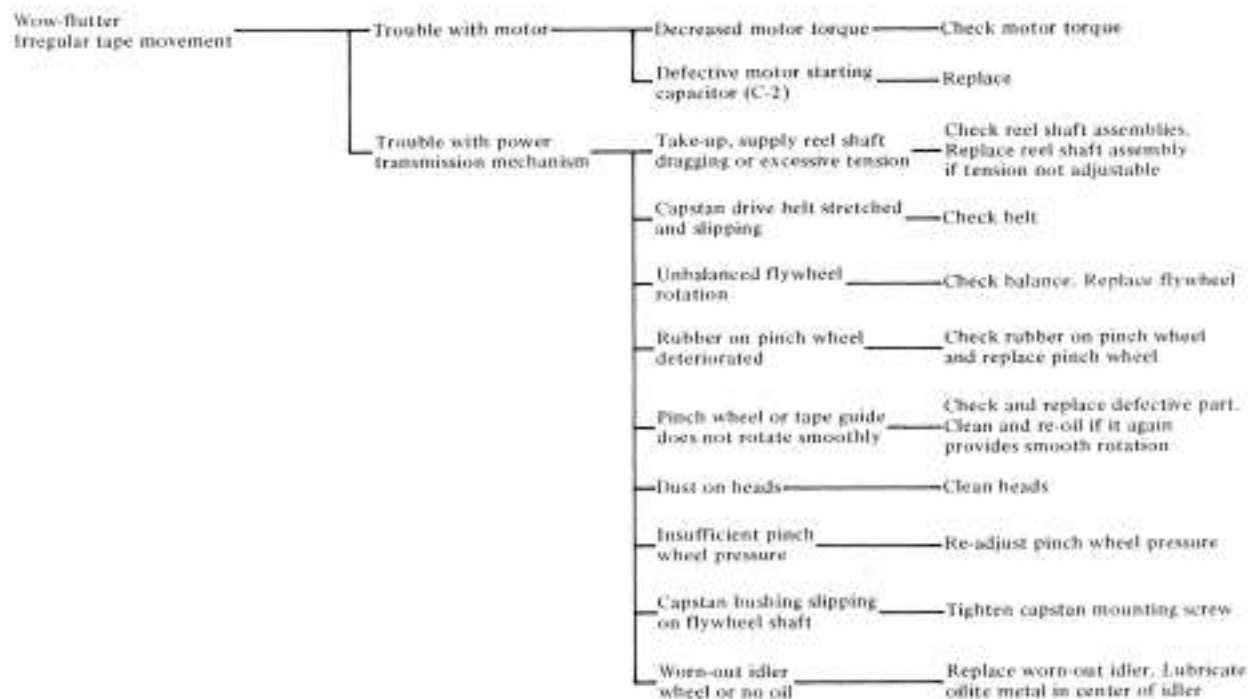
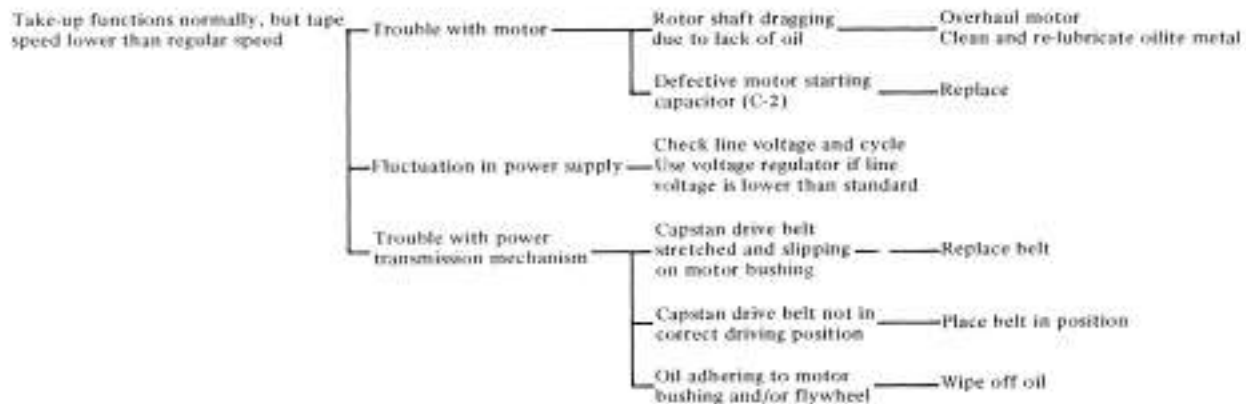

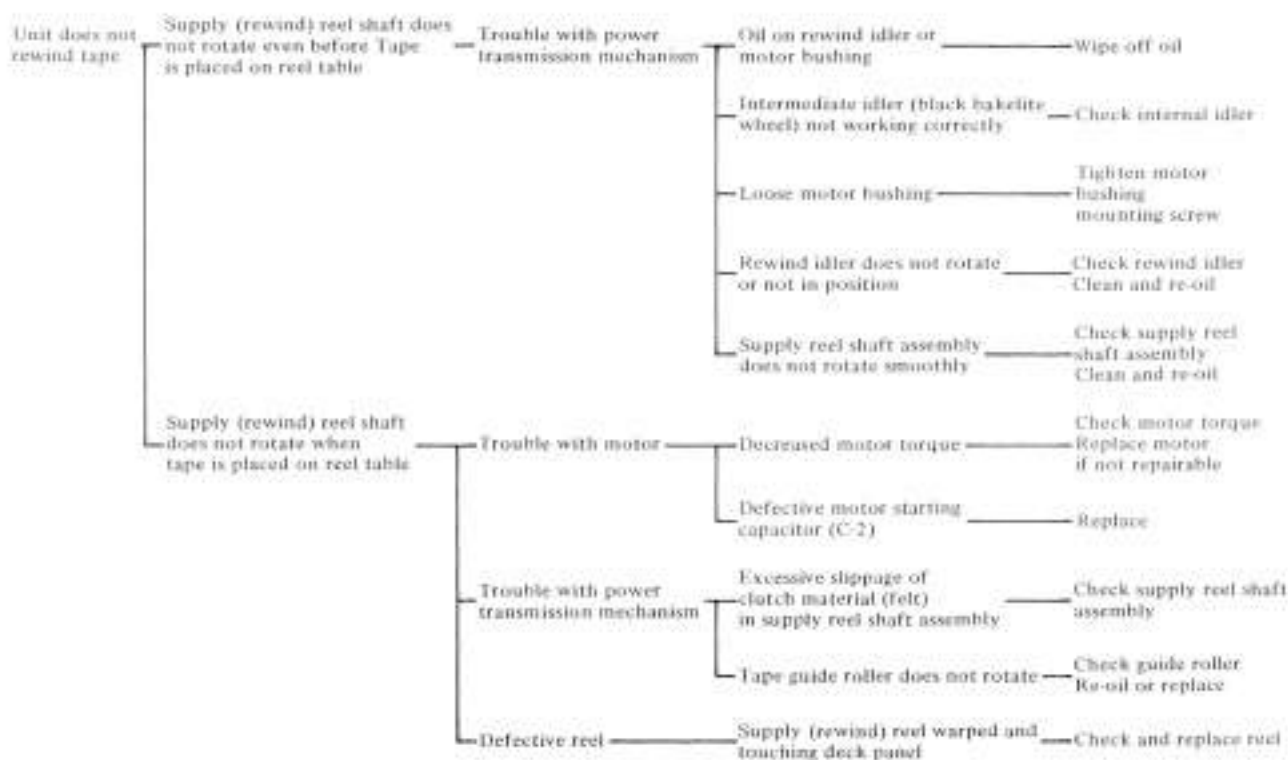
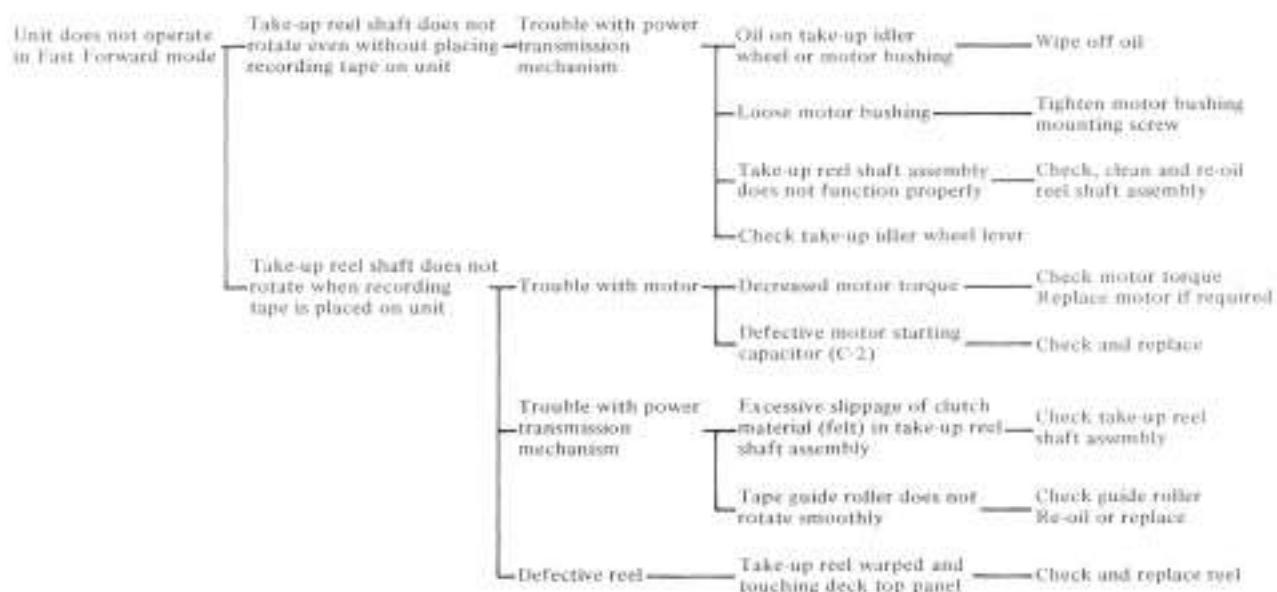

Loose tape winding in Rewind of Fast-Forward mode → Decreased back tension of take-up and supply reel shaft assemblies → Disassemble reel shaft assemblies and strengthen back tension

Tape spills when stopped from Rewind or Fast-Forward mode

- Excessive slippage of felt clutch material in take-up and rewind reel shaft assemblies → Re-adjust slippage of felt clutch material  
Replace defective reel shaft assembly if this re-adjustment is difficult
- Reels of different sizes are used. For example, 5" reel on take-up side and 7" reel on supply side → Always use reels of same size on both sides

