

HiFi ENGINE®

For more Hi-Fi manuals and set-up information
please visit www.hifiengine.com

EL-5

*UK Model
AEP Model*



ELCASET STEREO ELCASET DECK

SPECIFICATIONS

Power Requirements:	110, 120, 220 or 240 V ac, 50/60 Hz	Signal-to-noise Ratio:	DOLBY NR OFF
Power Consumption:	44W		With Type II ELCASET (FeCr)
Dimensions:	Approx. 430 (w) x 170 (h) x 320 (d) mm 17 (w) x 6 ³ / ₄ (h) x 12 ⁵ / ₈ (d) inches Including projecting parts and controls		62 dB at peak level (NAB) 62 dB (DIN, 1975 rev.) 54 dB (DIN, old)
Weight:	Approx. 10.5 kg, 23 lbs 2 oz		With Type I ELCASET (SLH)
			59 dB at peak level (NAB) 59 dB (DIN, 1975 rev.) 51 dB (DIN, old)
			DOLBY NR ON
Tape Speed:	9.5 cm/s (3 ³ / ₄ ips)		Improved by 5 dB at 1 kHz, 10 dB above 5 kHz
Fast Forward and Rewind Time:	Approx. 75 seconds (by LC-60)	Total Harmonic Distortion:	0.8%
Recording System:	4-track 2-channel stereo		
Bias Frequency:	160 kHz		

— Continued on page 2 —

****Dolby® and the double-D symbol are the trade marks of Dolby Laboratory Inc. Noise reduction system manufactured under license from Dolby Laboratory Inc. *0 dB = 0.775V**

SAFETY-RELATED COMPONENT WARNING!!

COMPONENTS IDENTIFIED BY SHADING ON THE SCHEMATIC DIAGRAMS AND IN THE PARTS LIST ARE CRITICAL TO SAFE OPERATION. REPLACE THESE COMPONENTS WITH SONY PARTS WHOSE PART NUMBERS APPEAR AS SHOWN IN THIS MANUAL OR IN SUPPLEMENTS PUBLISHED BY SONY.



Look for this mark on all products manufactured under the ELCASET standard.

SONY®

SERVICE MANUAL

Frequency Response: DOLBY NR OFF
With Type II ELCASET (FeCr)
15–25,000 Hz (NAB)
25–20,000 Hz \pm 3 dB (NAB)
20–22,000 Hz (DIN)
With Type I ELCASET (SLH)
15–23,000 Hz (NAB)
25–18,000 Hz \pm 3 dB (NAB)
20–20,000 Hz (DIN)

Wow and Flutter: 0.06% WRMS (NAB)
 \pm 0.12% (DIN)

Inputs: MIC (phone jacks) 2
sensitivity 0.3 mV (-68 dB)
for low impedance microphone
LINE IN (stereo binaural jack) 1
(phono jacks) 2
sensitivity 0.095 V (-18 dB)
input impedance 100 k ohms

Outputs: LINE OUT (phono jacks) 2
output level 0.775V (0 dB)
at load impedance 100 k ohms with
LEVEL ADJUST control turned fully
clockwise
suitable load impedance more than
10 k ohms
HEADPHONES 1
suitable load impedance 8–32 ohms
REC/PB Connector: Input impedance less than 10 k ohms
Output impedance less than 10 k ohms

SECTION 1 OUTLINE

1-1. BLOCK DIAGRAM - System Control Section -

Note: REC: RECORD
FWD: FORWARD
FF: FAST FORWARD
REW: REWIND

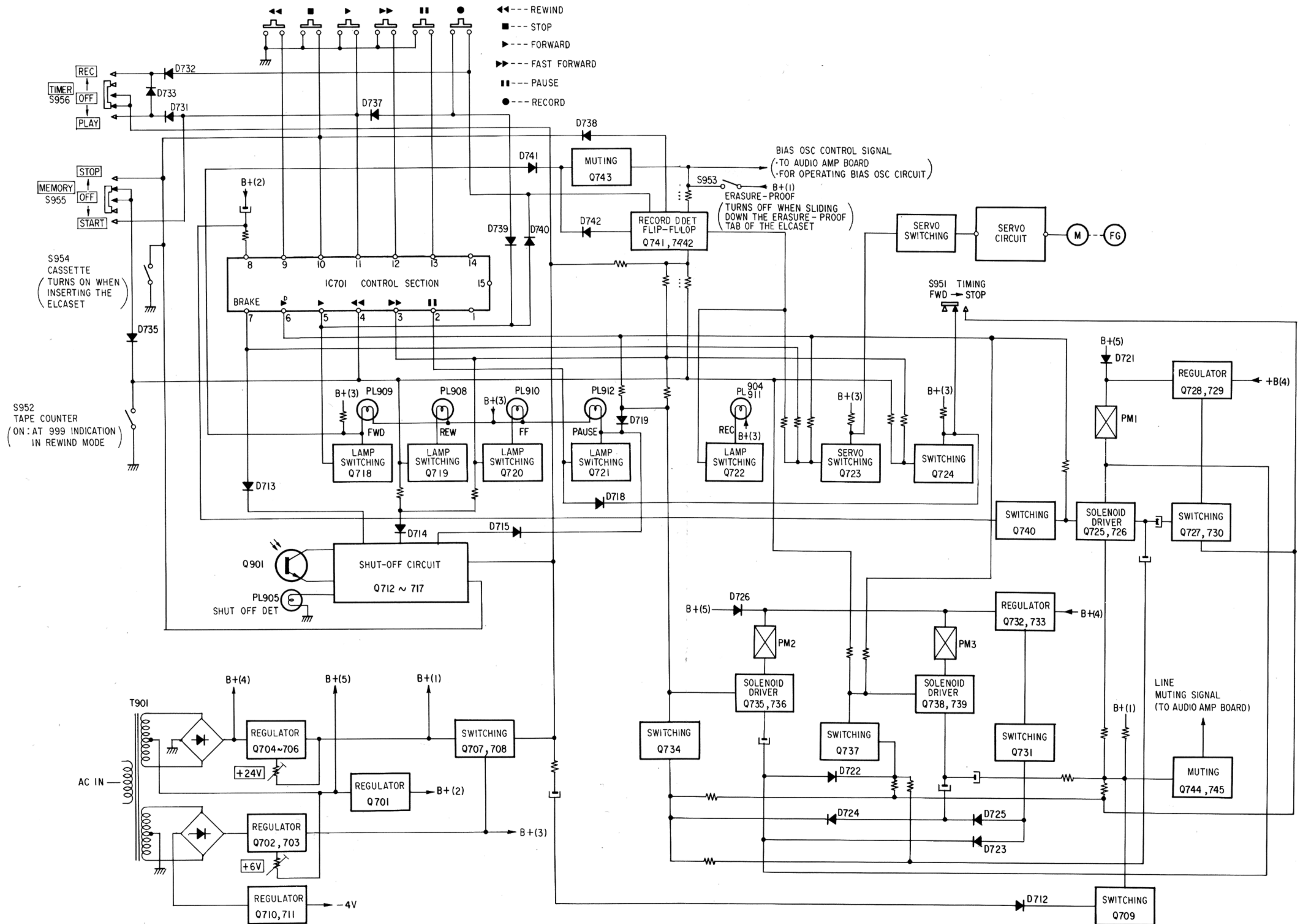

1-2. BLOCK DIAGRAM – Amplifier Section –

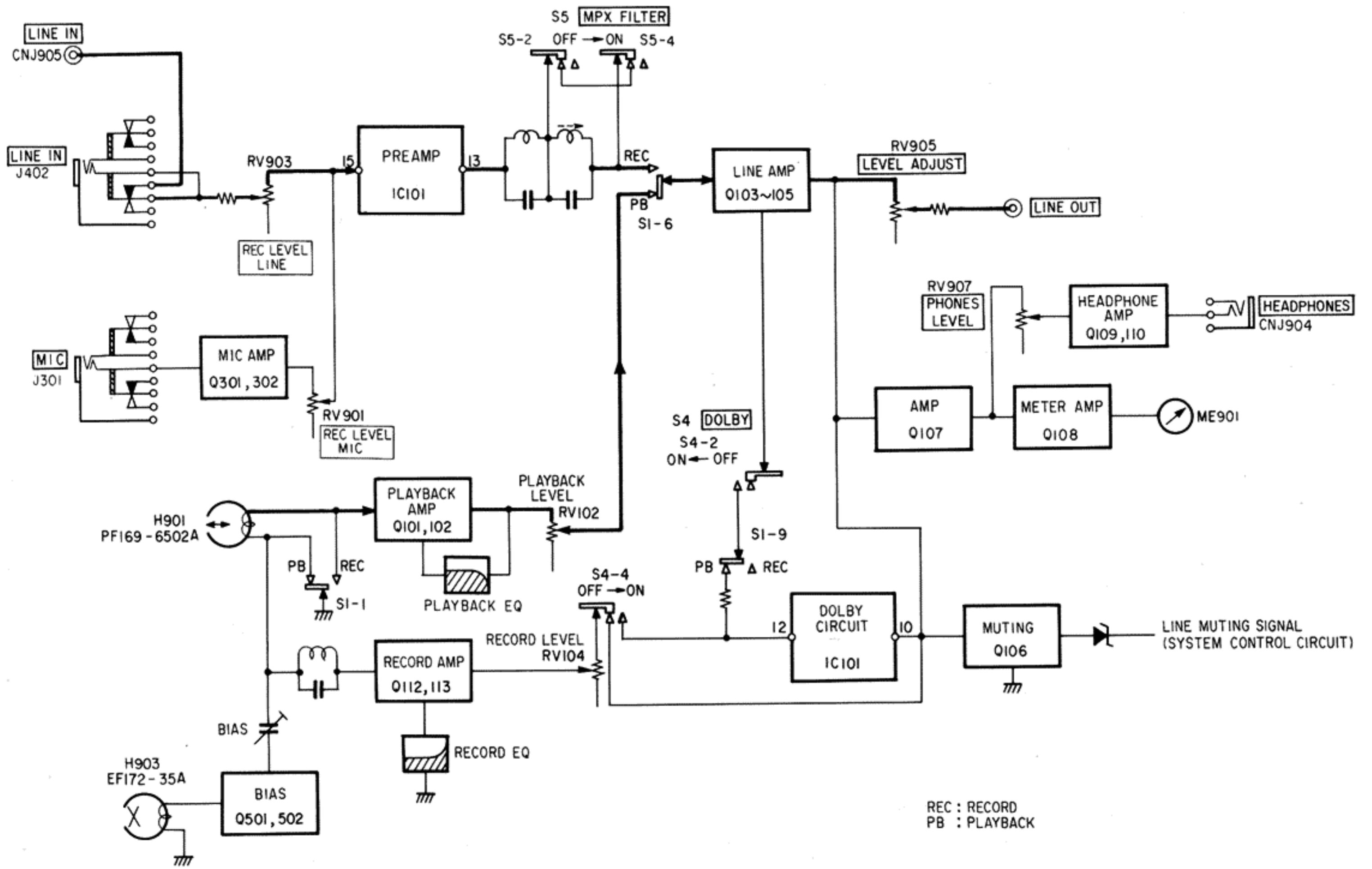

1-3. CIRCUIT DESCRIPTION

The EL-5 system control circuit employs IC701 (CX738) which supplies six different output signals (PAUSE, forward, fast forward, rewind, delay-forward, and brake). (See the detailed circuit description of EL-7).

SOLENOID DRIVE CIRCUITS

The following table indicates each operation of the three solenoids for each mode.

Mode Solenoid	Forward	Fast Forward	Rewind	PAUSE	Record	Record/PAUSE or Forward/PAUSE
PM1 (Shifter)	○	X	X	○	○	○
PM2 (Fast Forward)	○	○	X	X	○	X
PM3 (Rewind)	X	X	○	X	○	○

○: energized

X: de-energized

1. STOP mode → forward mode (energized PM1 and PM2) (See Figs. 1-2 and 1-3)

- When the delay forward signal is applied to the base of Q725 and Q735 from terminal 6 of IC701, Q725 and Q726 turn ON to energize PM1.
- When Q725 and Q726 are both ON, C720 discharges, and the Q727's base voltage is decreased. Q727 turn OFF. So Q728 and Q729 turn ON, and PM1 is energized by the high voltage while C720 is discharged.
- In this period, Q730 turns ON. Then Q734 turns ON by a base current flowing via R791. Therefore, the delay forward signal applied to the base of Q735 from terminal 6 of IC701 is grounded at Q734. Q735 and Q736 turn OFF, and PM2 is not energized.
- The other base current is also applied to Q734 via S951 and R791 during forward mode to secure the mechanical operation.
- After discharging C720, Q727 turns ON. (See Fig. 1-3). Consequently, Q728, Q729, Q730 and Q734 turn OFF, and Q735 and Q736 turn ON, so PM2 is energized. (Q731, Q732 and Q733 constitute the solenoid kick circuit. See the circuit description of EL-7).
- Energized both solenoids, PM1 and PM2, place EL-5 in the forward mode.

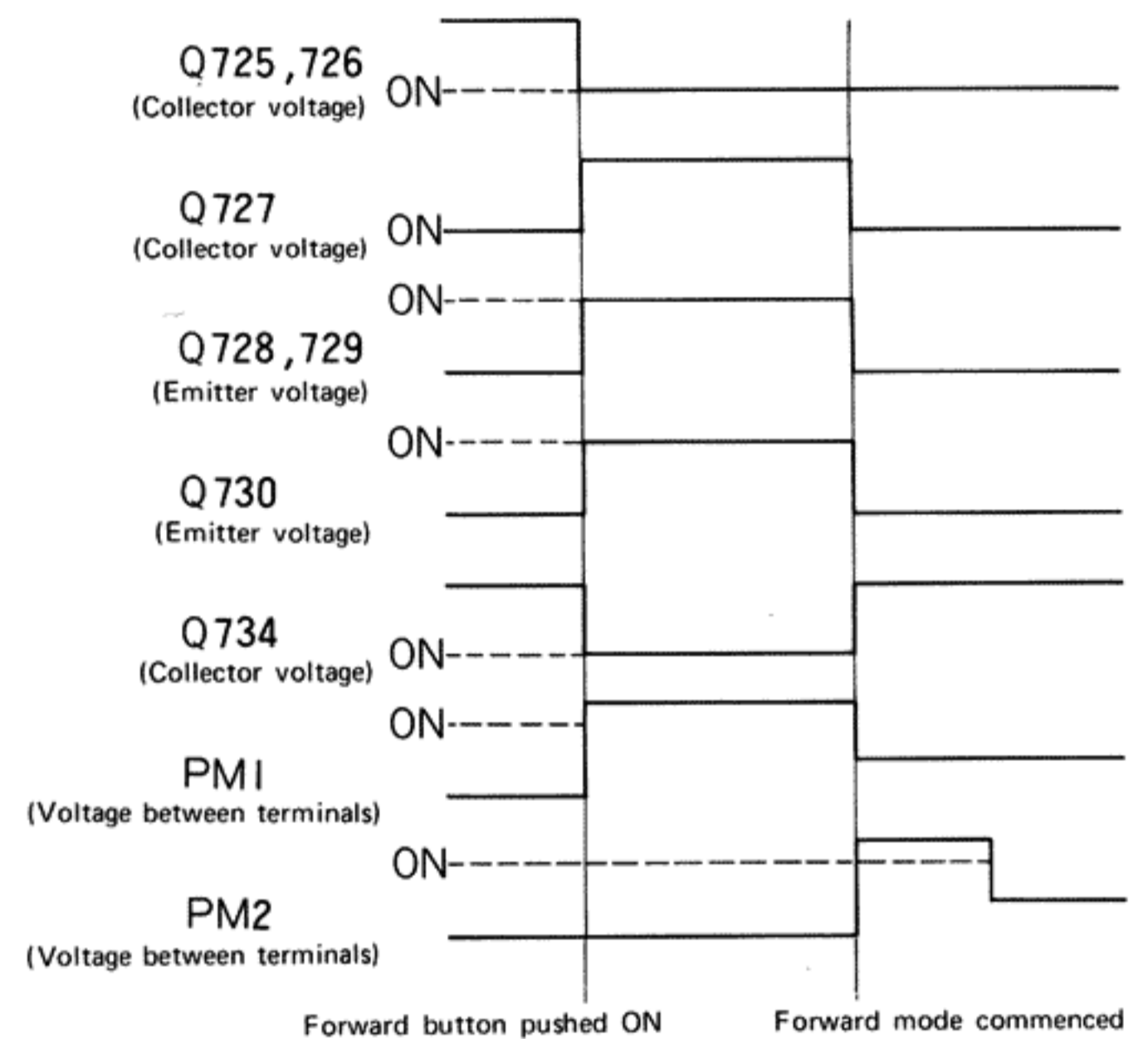

Fig. 1-1 Time Chart of Energizing PM1 and PM2

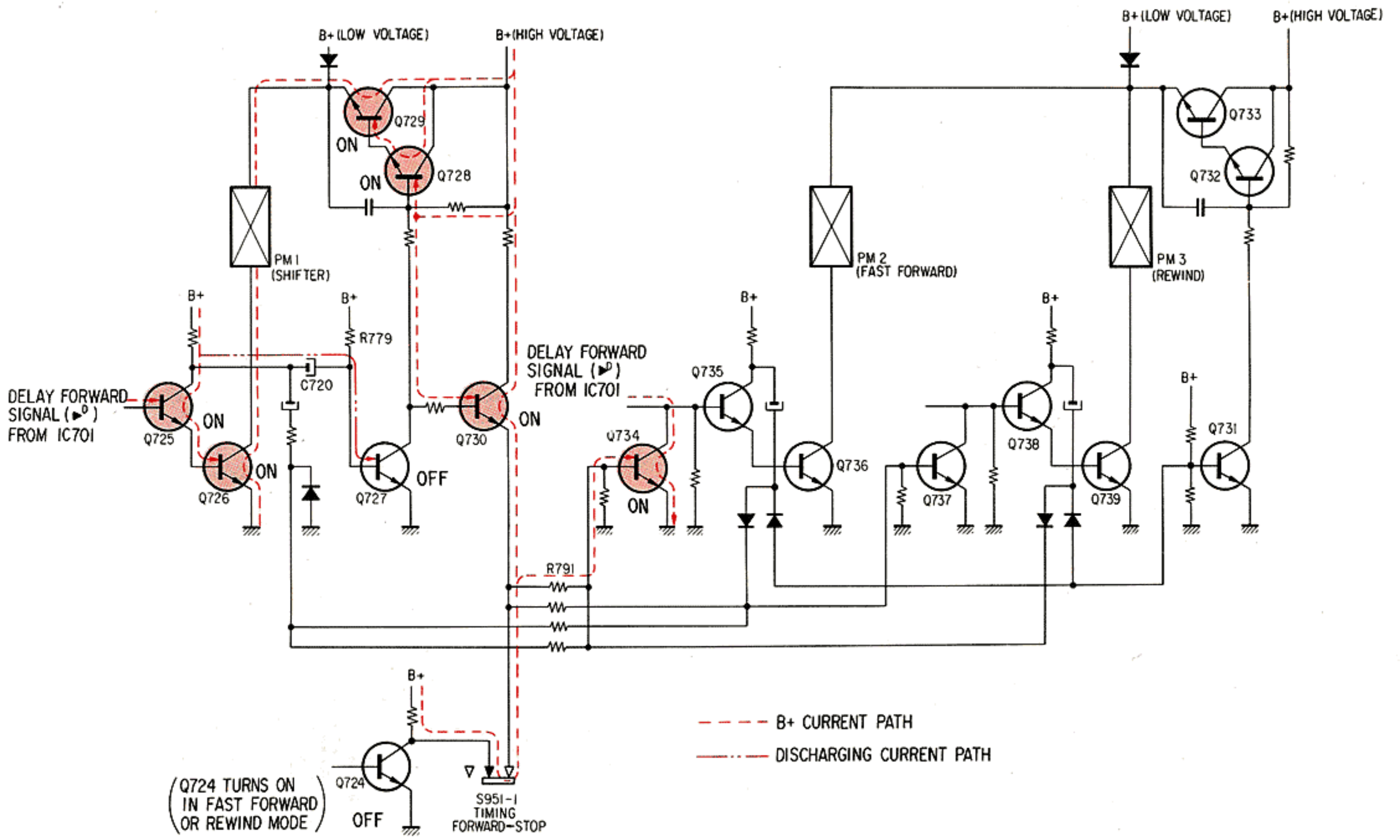

Fig. 1-2 Forward Button Pushed ON

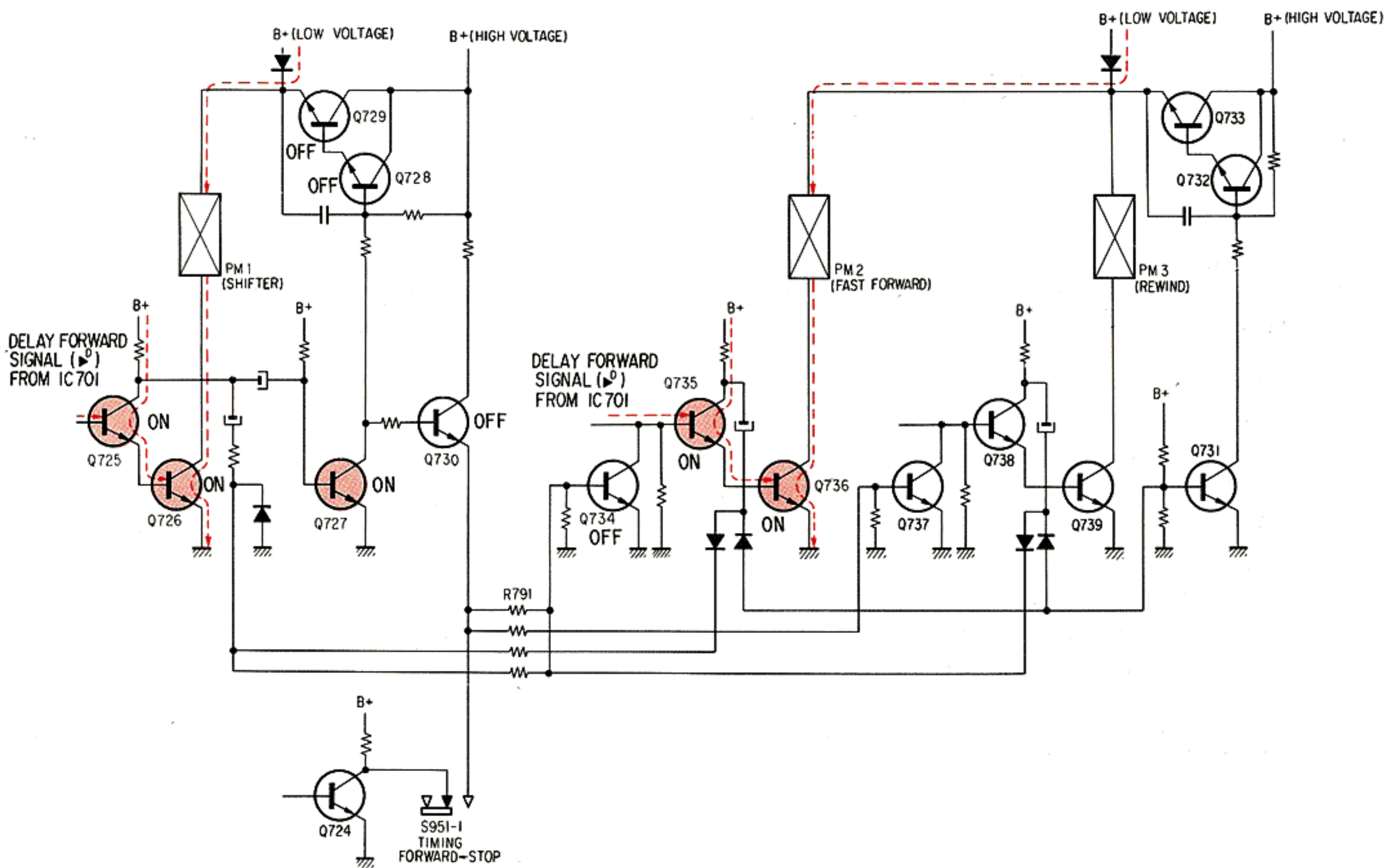

Fig. 1-3 Forward mode Commenced

2. STOP mode → fast forward or rewind mode (energized PM2 or PM3) (See Fig. 1-4)

When the fast forward signal is applied to the base of Q735 from terminal 3 of IC701, Q735 and Q736 turn ON, and PM2 is energized. The energized PM2 places EL-5 in the fast forward mode. For

rewind mode, Q738 and Q739 turn ON by the rewind signal from terminal 4 of IC701, and PM3 is energized. The energized PM3 places EL-5 in the rewind mode. (Q731, Q732 and Q733 constitute the solenoid kick circuit. See the circuit description of EL-7).

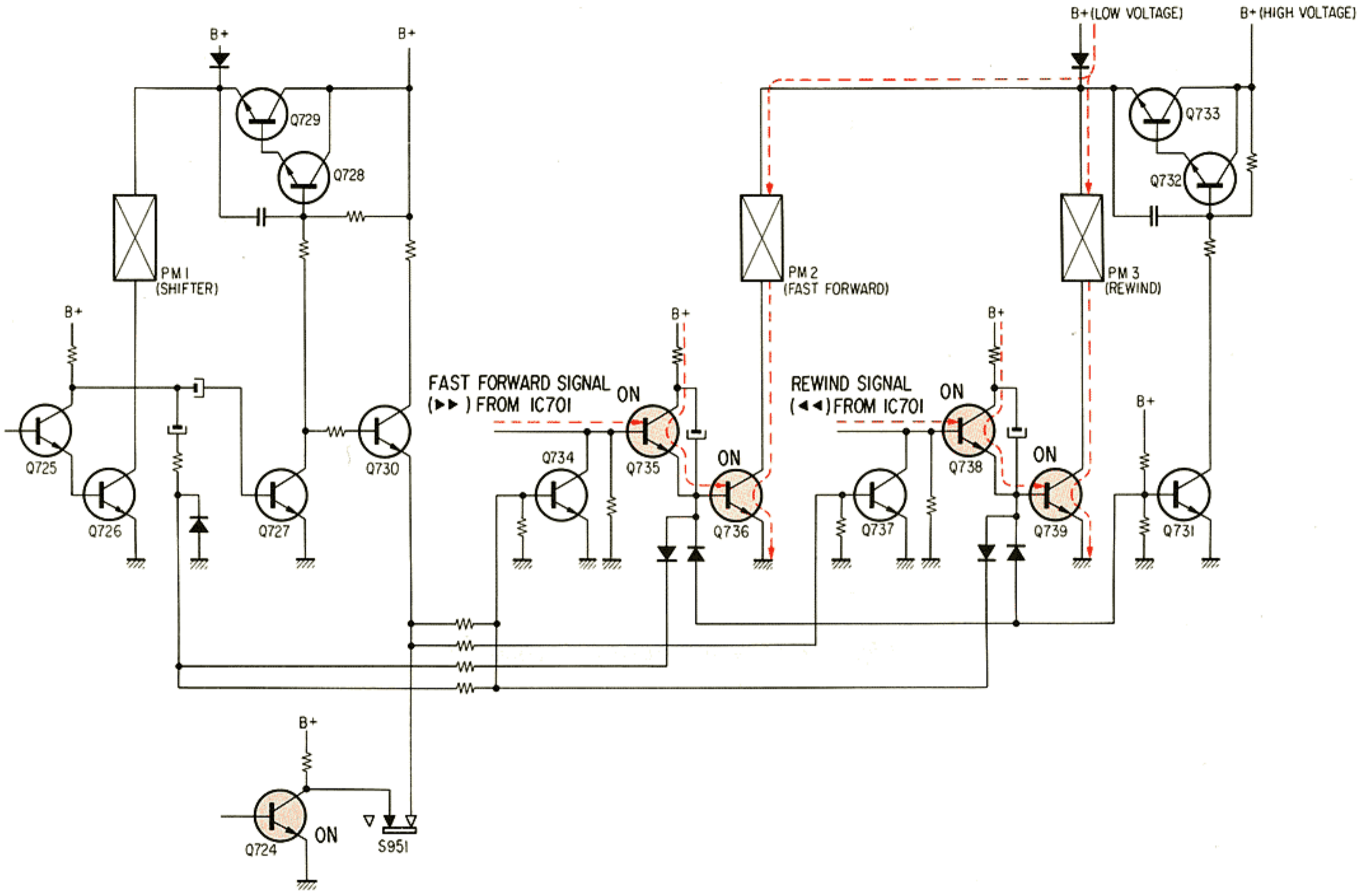

Fig. 1-4 Fast Forward or Rewind Mode

3. STOP mode → record mode (energized PM1, PM2, PM3) (See Fig. 1-5)

1. When the record button is pushed, the record control signal is applied to the base of Q725 and Q738 from the flip-flop Q741/Q742. Then Q725 and Q726 turn ON, and PM1 is energized. According to the operation of Q737 (as same as the operation of Q734 described on section 1), Q738 and Q739 turn ON after PM1 is energized, and PM3 is energized. Energizing of these two solenoids places EL-5 in the record STAND BY mode.
2. Then when the forward button is pushed with the record button pushed, the delay forward (▶^D) signal from terminal 6 of IC701 is applied to the base of Q735, so Q735 and Q736 turn ON, and PM2 is energized to place EL-5 in record mode.

4. Record mode → PAUSE mode (energized PM1, PM2, PM3 → de-energized PM2) (See Fig. 1-5)

When the PAUSE button is pushed in forward mode, the PAUSE signal from terminal 2 of IC701 is applied to the base of Q721, so Q721 turns ON. The base of Q735 is grounded, then Q735 and Q736 turn OFF, PM2 is de-energized to place EL-5 in the PAUSE mode.

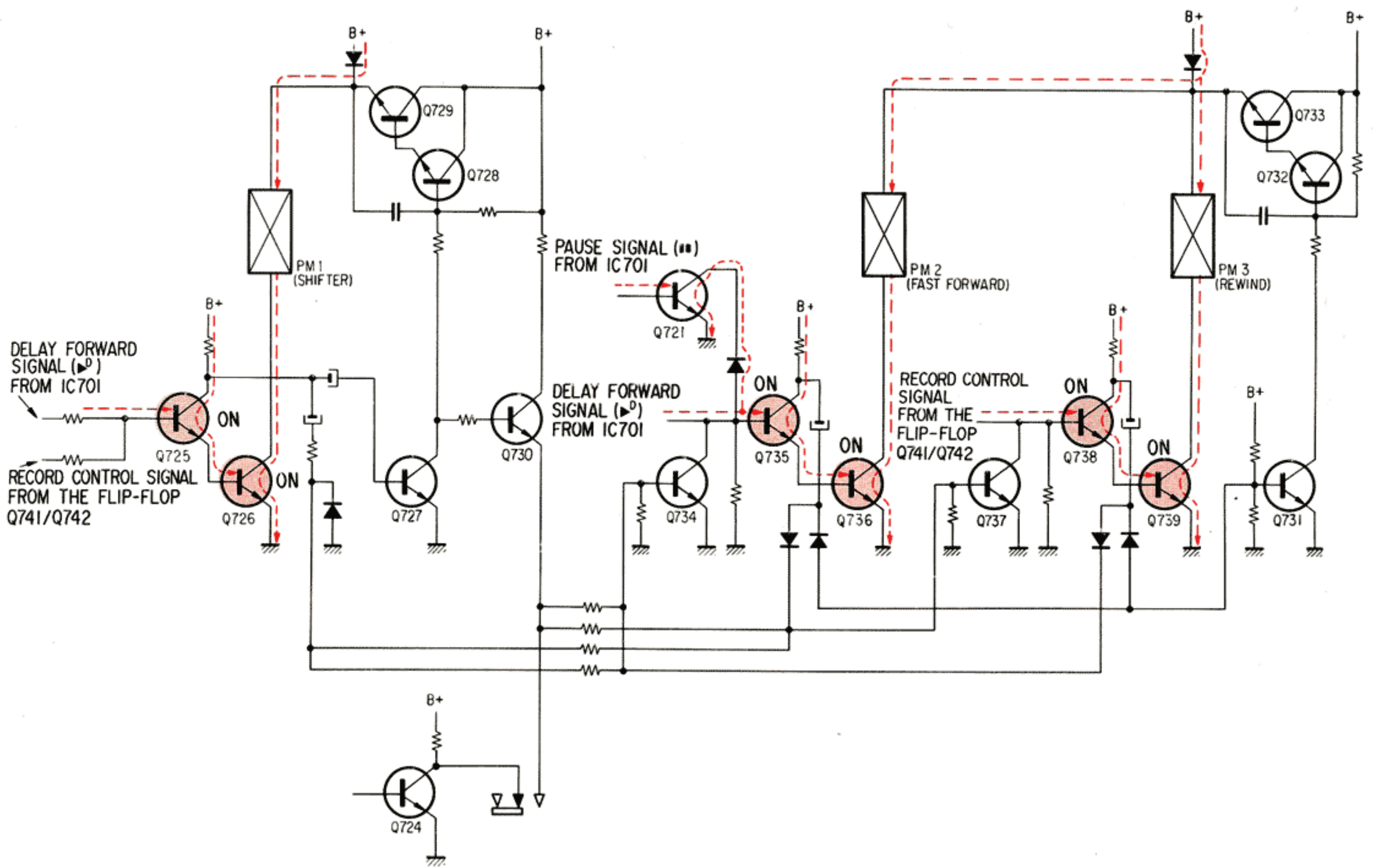

Fig. 1-5 Record/PAUSE Mode

5. Record mode → fast forward or rewind mode (via temporary STOP mode) (See Fig. 1-7)

When changing directly to the fast forward mode from the record mode, Q725 and Q726 turn OFF and the charge-up current of C721 is applied to the base of Q734 via R778 and R790 while C721 is charged up. Q734 turns ON, and the fast forward (▶▶) signal from IC701 is temporarily grounded. Q734 turns OFF after C721 is fully charged, so the fast forward signal from IC701 energizes PM2 to place EL-5 in the fast forward mode. When changing directly to the rewind mode from the record mode, a similar chain of events, including the switching of Q737, places EL-5 in rewind mode. Switching of Q737 makes a temporary STOP during the rewind signal is momentarily grounded.

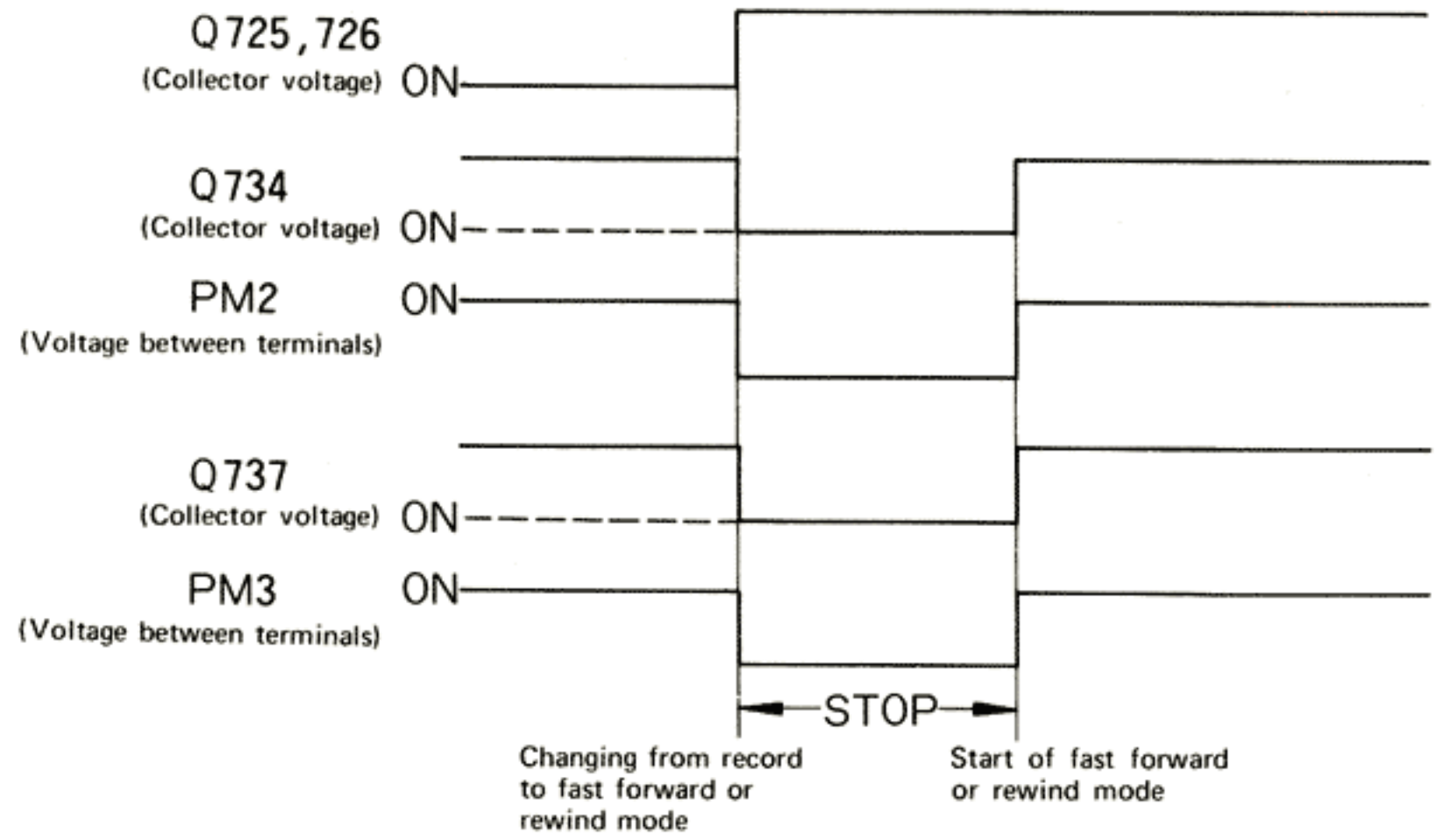

Fig. 1-6 Time Chart

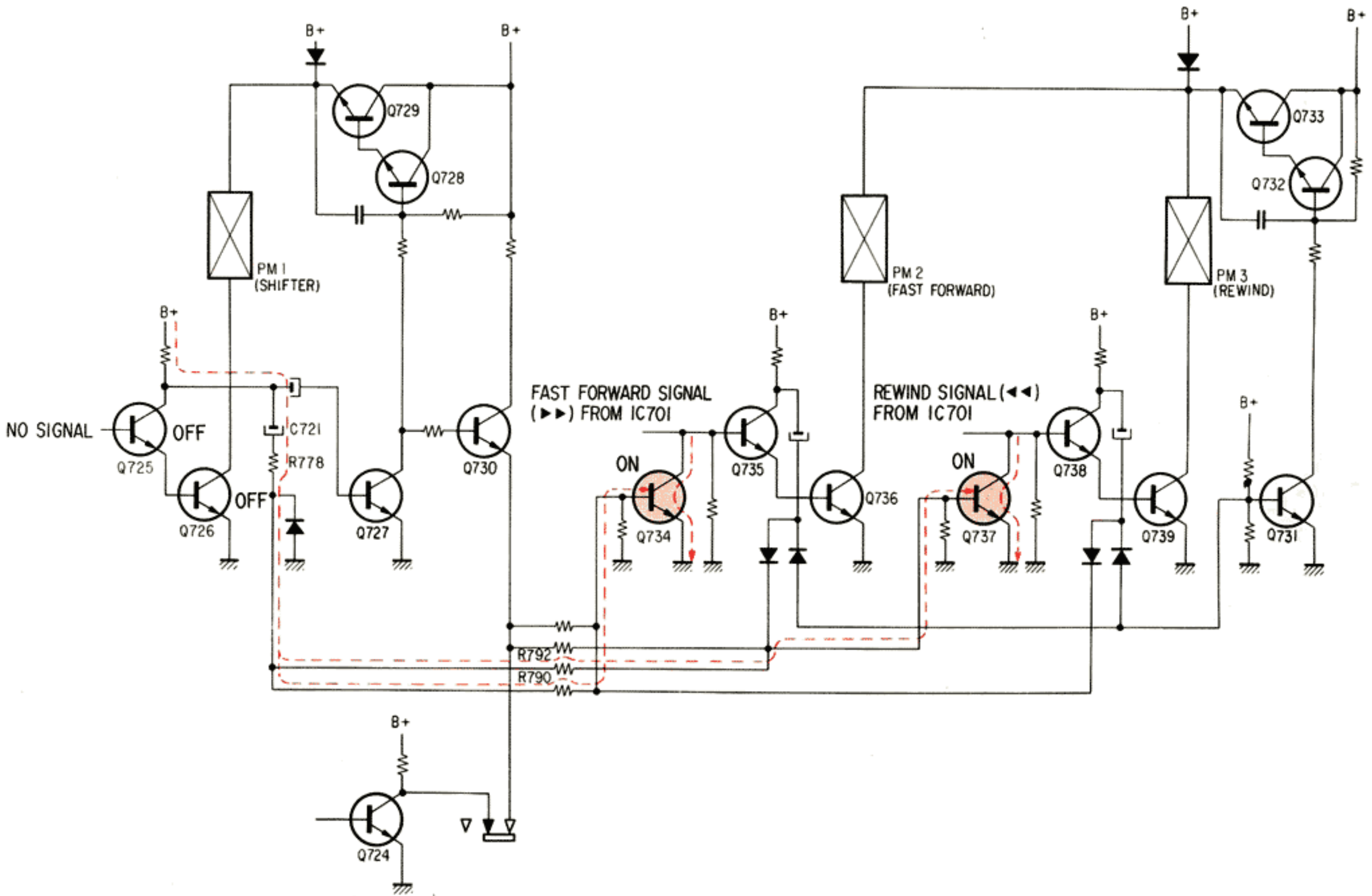

Fig. 1-7 Record Mode → Fast Forward or Rewind Mode

MUTING CIRCUIT

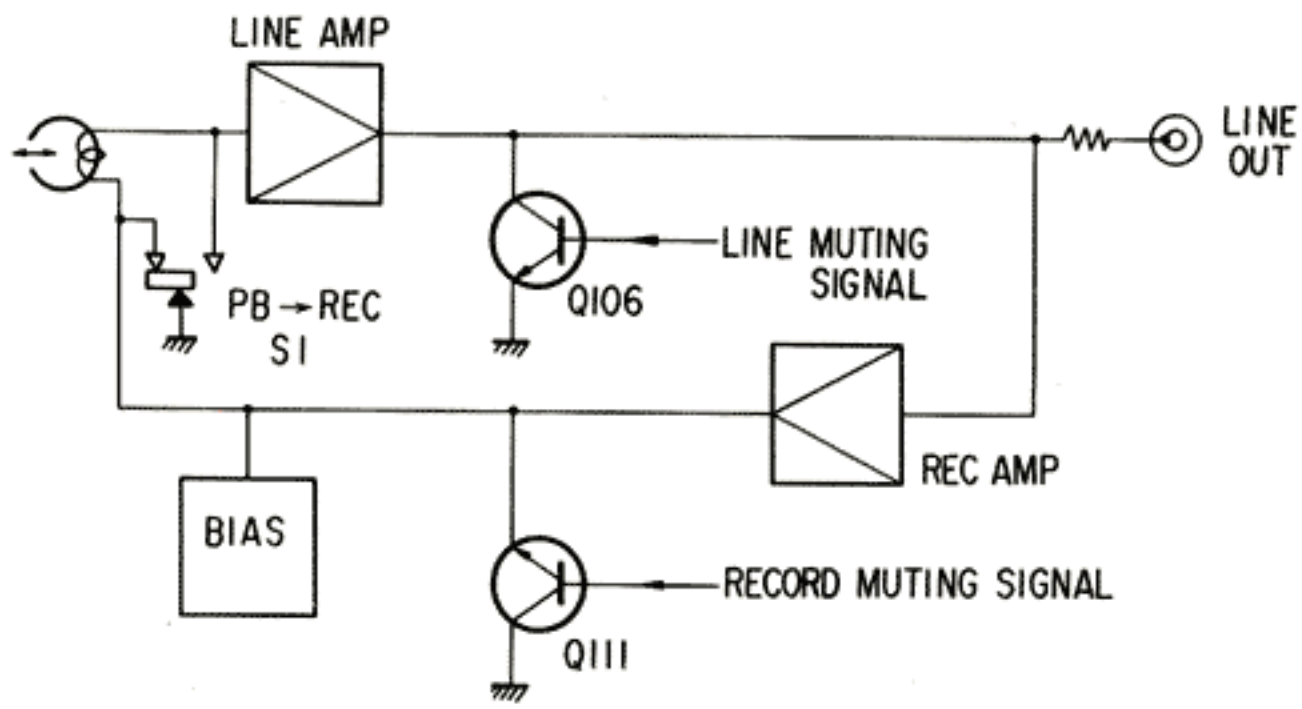

Fig. 1-8 Muting Signal

1. When power switch turned ON (See Fig. 1-9)

Stop signals are generated at Q707 and Q708 by the start-up of the power supply voltage. (See the circuit description of EL-7 for the details on stop signals).

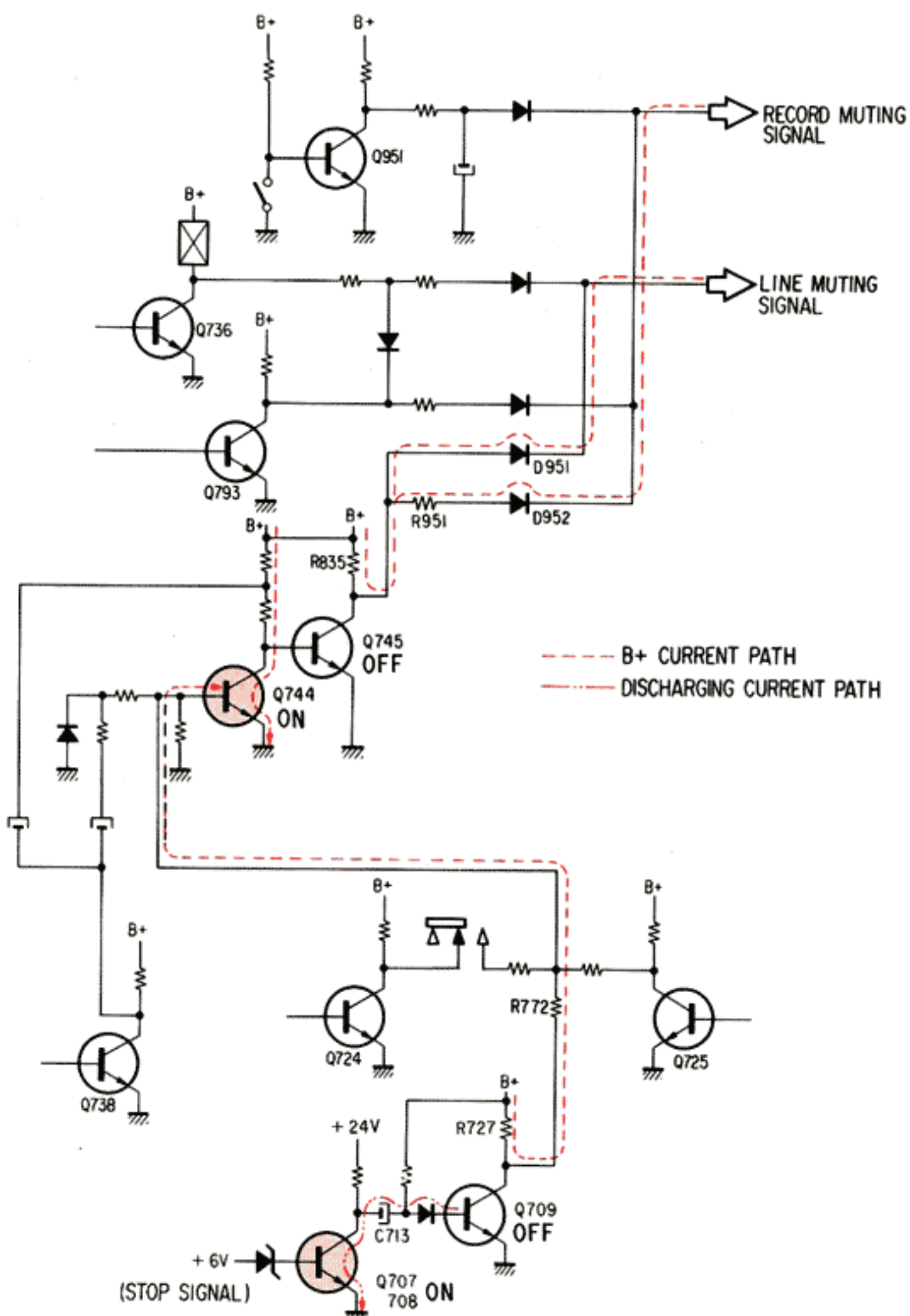

Fig. 1-9 Power Switch Turning ON

1. Q707 and Q708 turn ON after 2 seconds from turning the power switch to ON. C713 discharges when Q707 and Q708 turn ON, thus Q709's base voltage is decreased and Q709 turns OFF.
2. Q744 turns ON by a base current flowing via R727 and R772, and then Q745 turns OFF. So the record muting signal (via R835, R951 and D952), and the LINE muting signal (via R835 and D951) are applied to the audio circuit.

2. STOP mode (See Fig. 1-10)

Q724 is OFF in STOP mode. And Q744 turns ON by the base current flowing via R770, S951-1 and R771. Thus Q745 turns OFF, so the LINE muting and record muting signals are applied to the audio circuit.

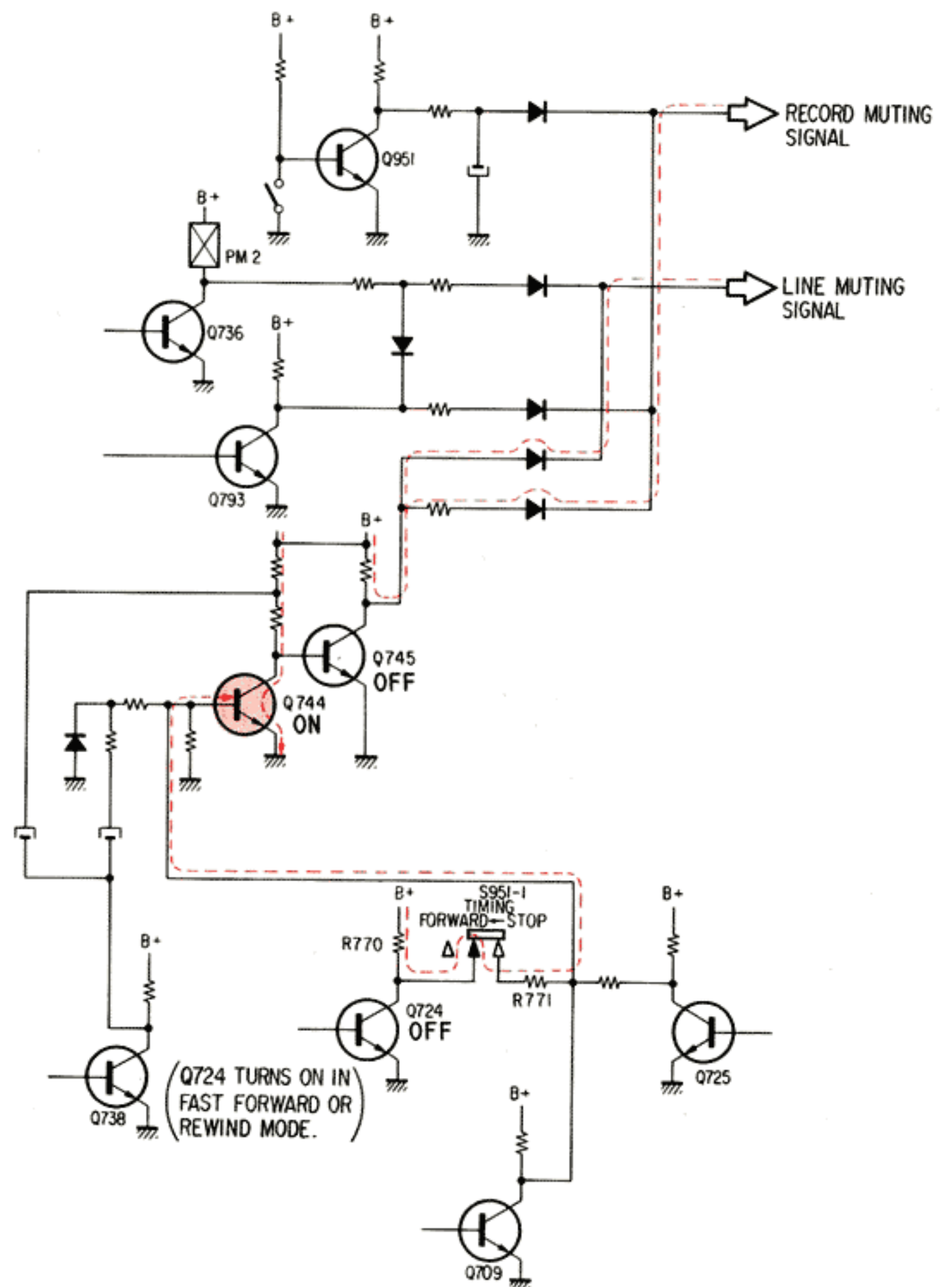

Fig. 1-10 Stop Mode

3. Forward mode (See Fig. 1-11)

Q739 is OFF in forward mode, so only the record muting signal is applied to the audio circuit via PM3, R957, and D955.

4. Fast forward or rewind mode (See Fig. 1-12)

Q725 is OFF in fast forward or rewind mode, so Q744 turns ON by the base current flowing via R776 and R733. Consequently, Q745 turns OFF, and the LINE muting and record muting signals are applied to the audio circuit.

5. STOP mode → record mode, or record mode → STOP mode (See Fig. 1-13)

1. When the record button is pushed in STOP mode, Q738 turns ON. Consequently Q745 turns OFF by the discharging current of C738. So the LINE muting and record muting signals are applied to audio circuit.
2. When the STOP button is pushed in record mode, Q738 turns OFF. Then Q744 turns ON by the charging current of C739, and Q745 turns OFF. So the LINE muting and record muting signals are applied to the audio circuit.

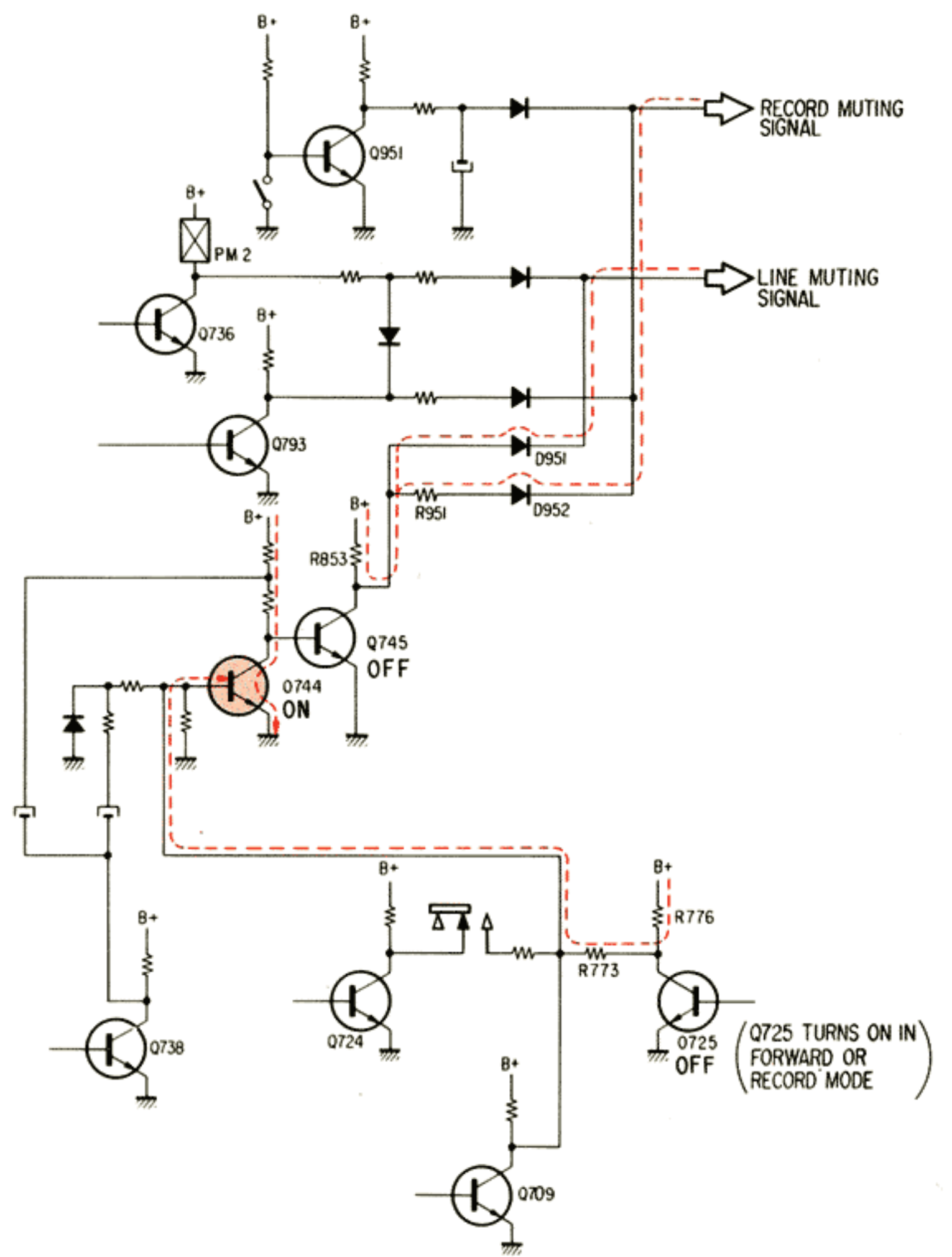

Fig. 1-12 Fast Forward or Rewind Mode

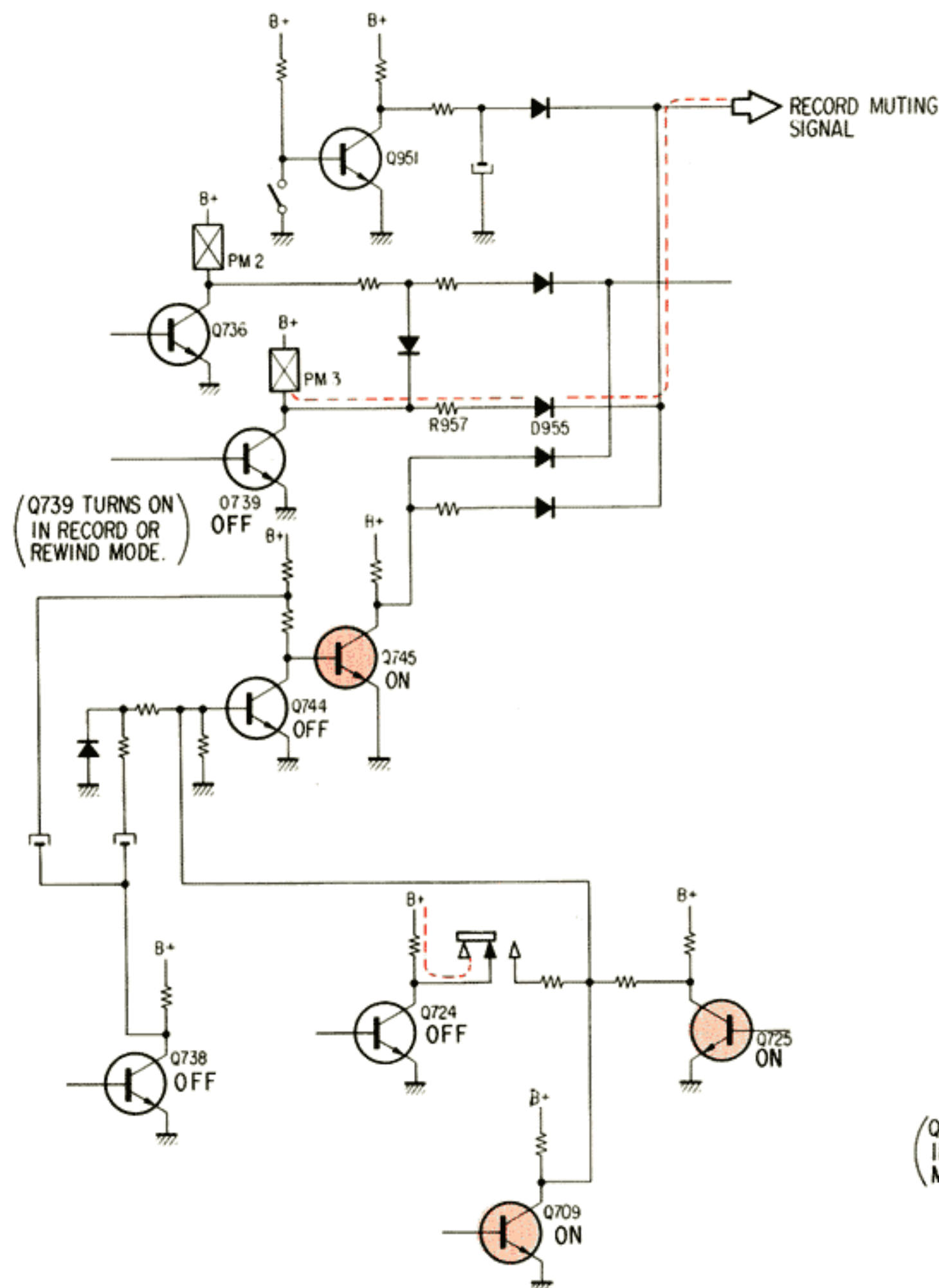

Fig. 1-11 Forward Mode

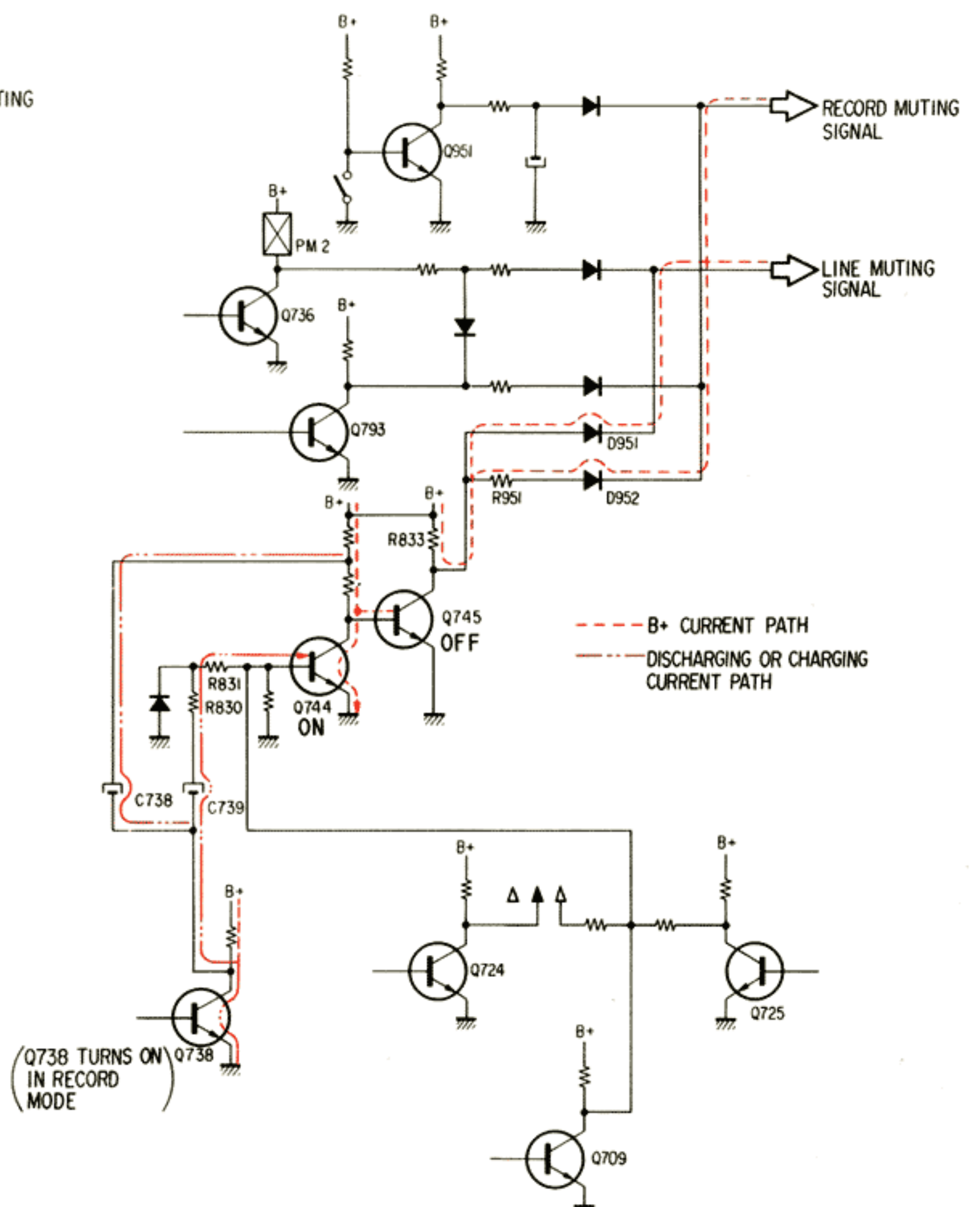
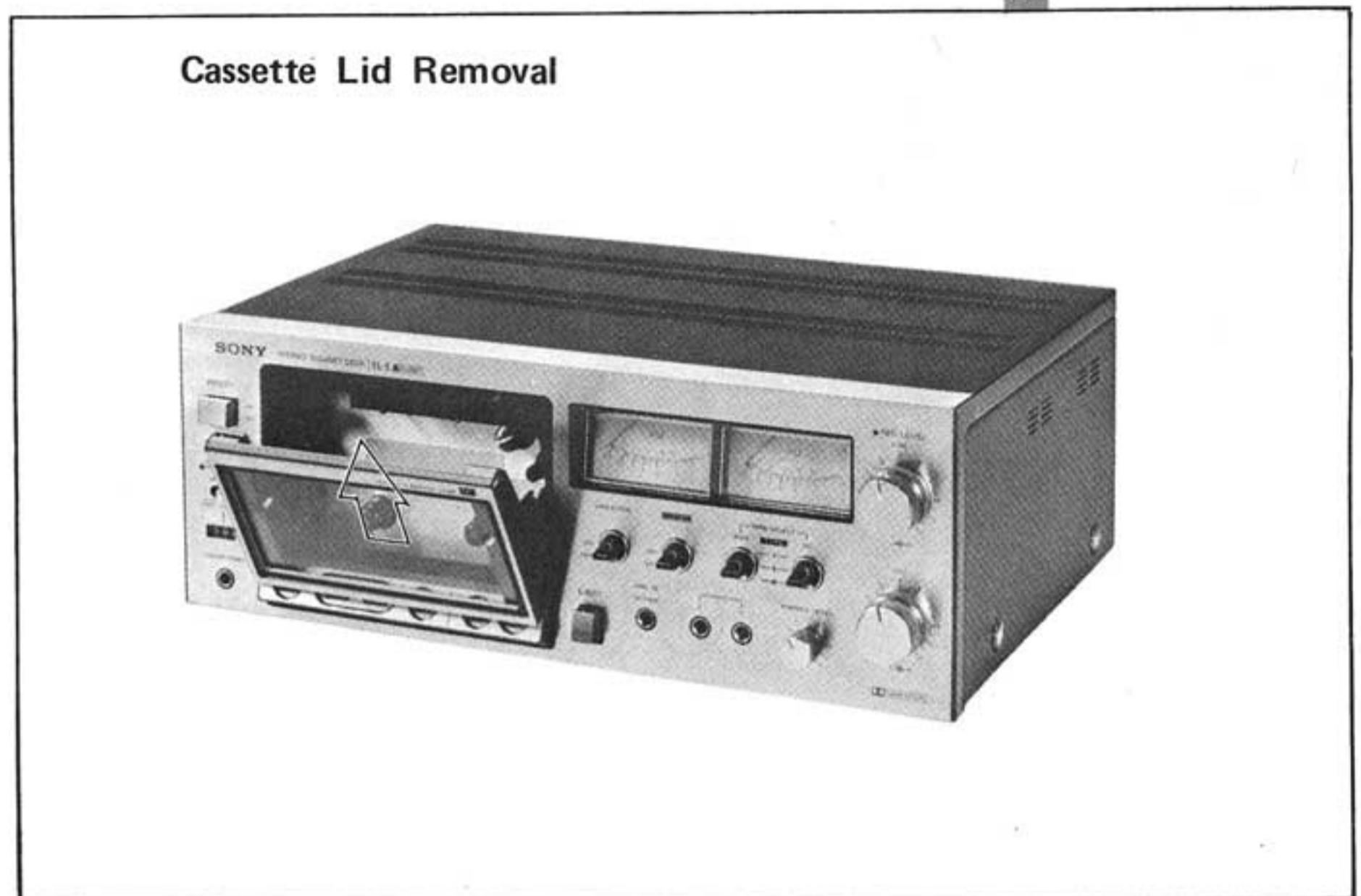
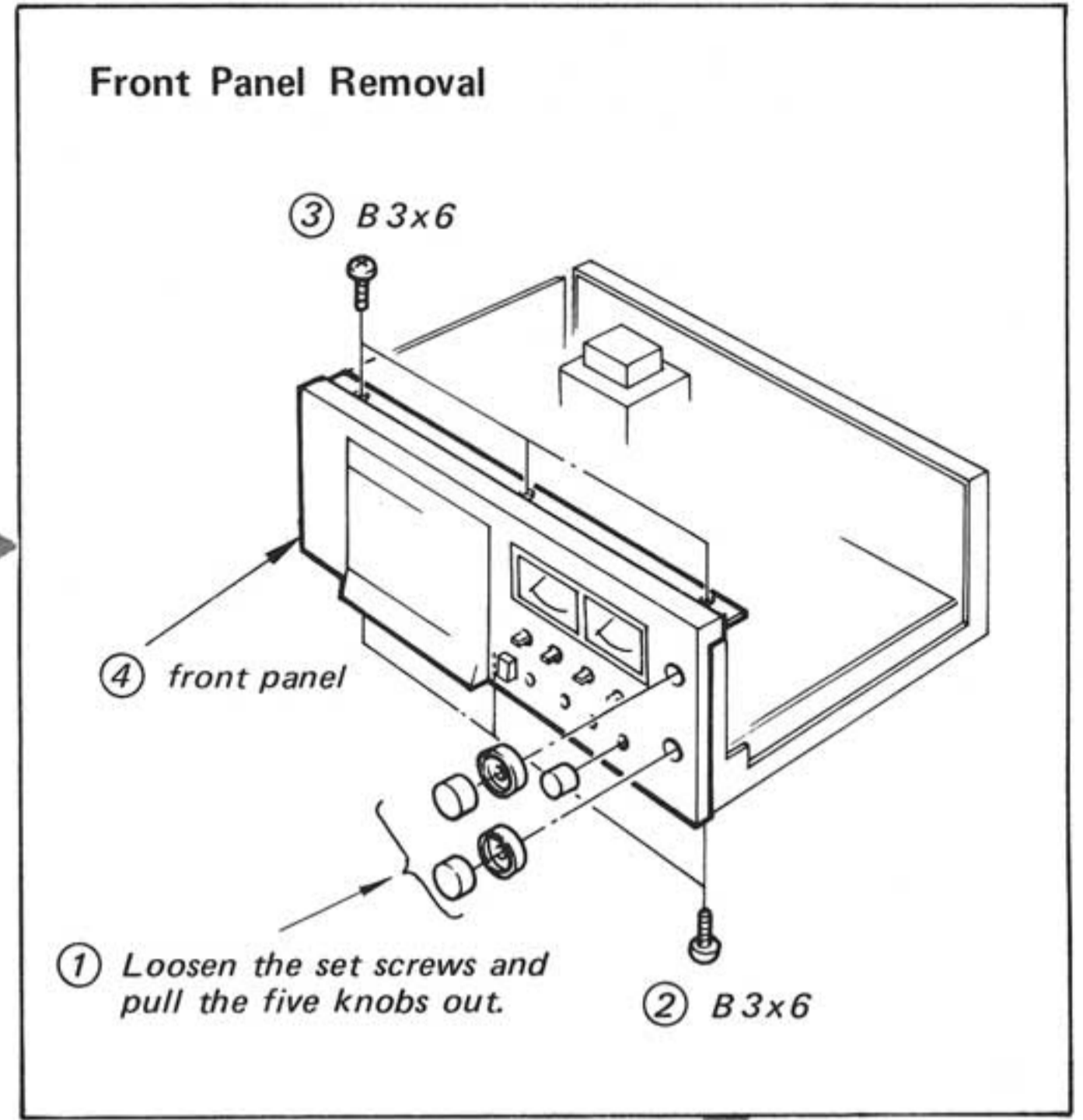
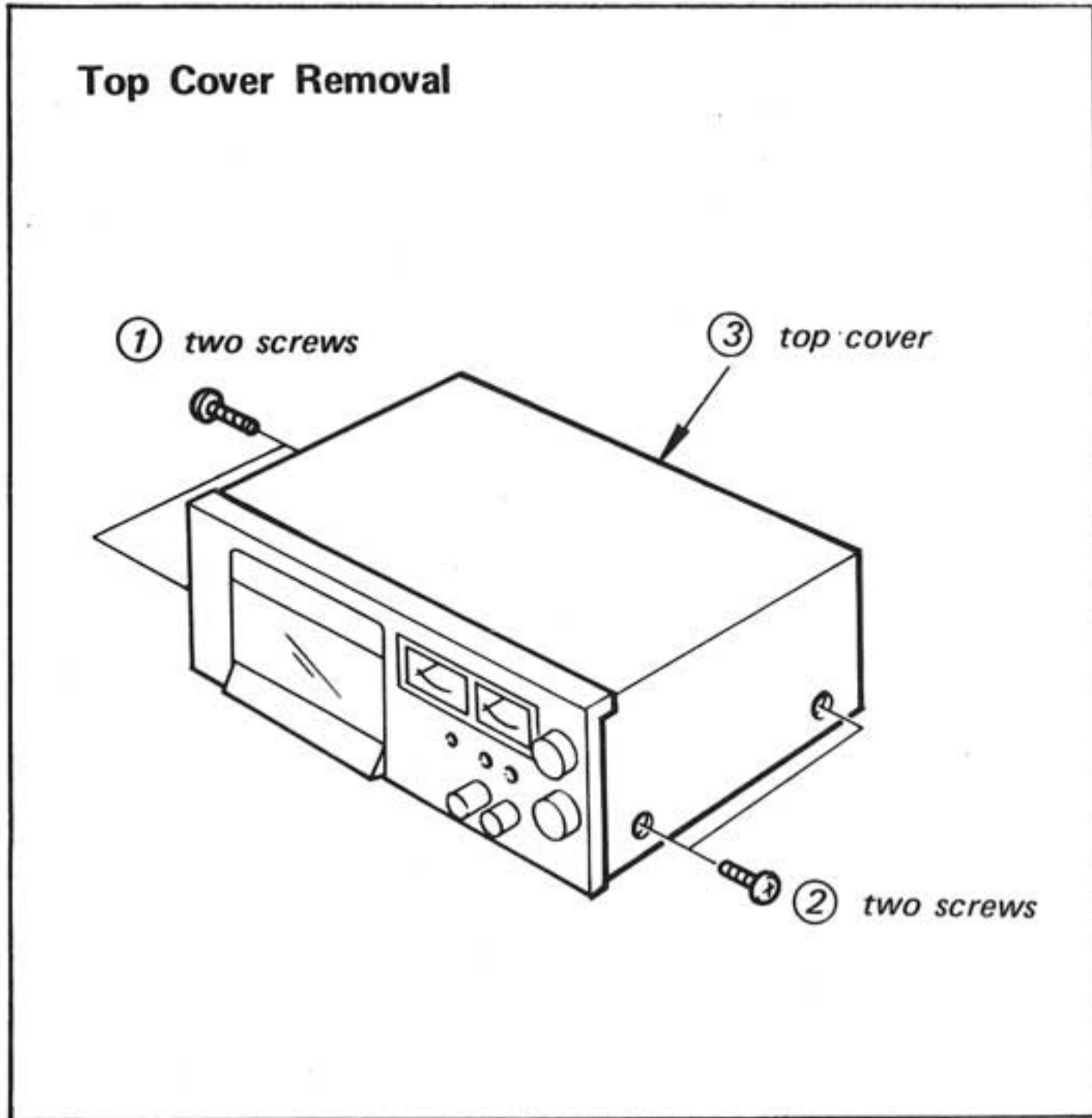
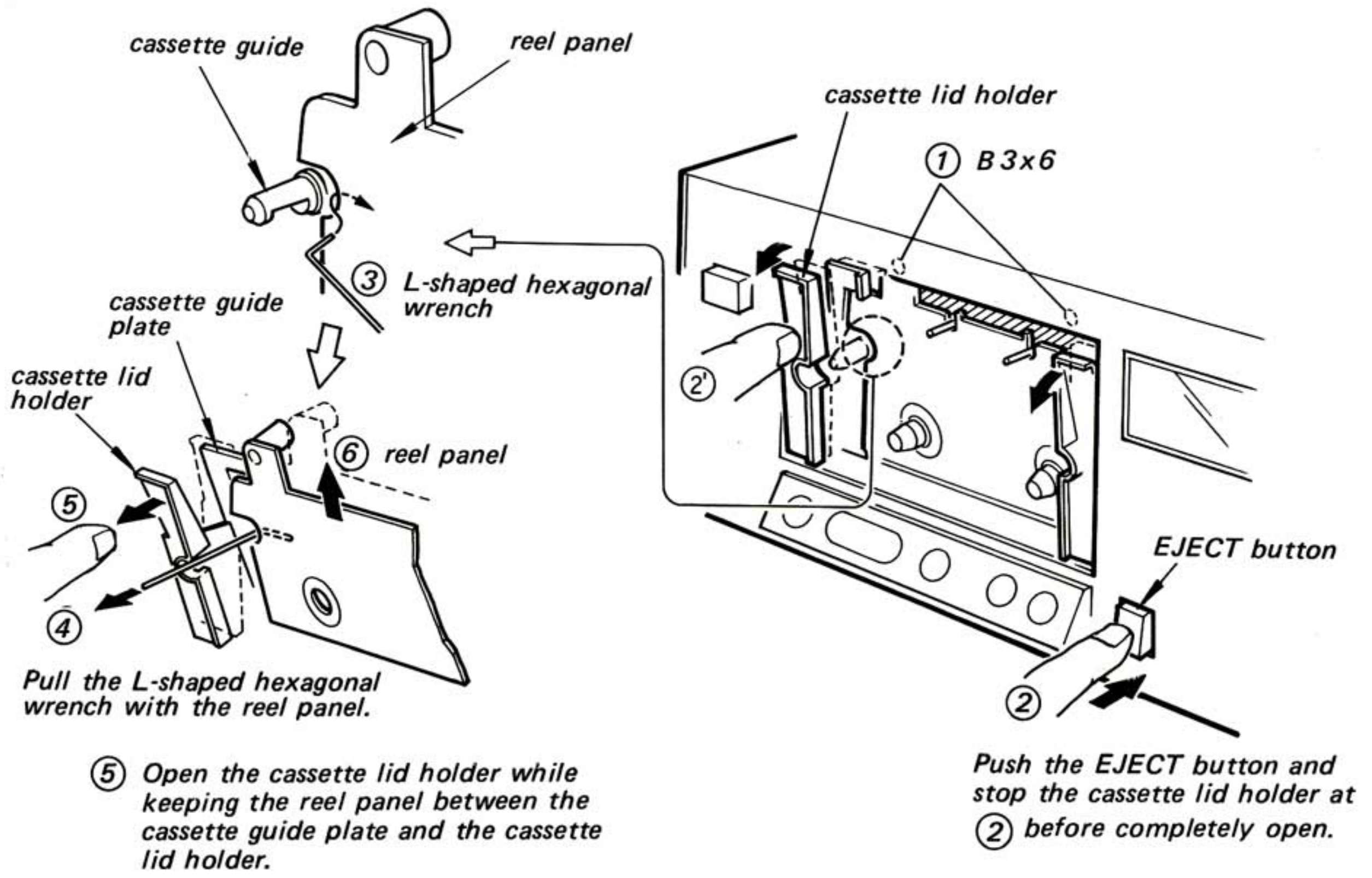

Fig. 1-13 Stop Mode → Record Mode or Record Mode → Stop Mode

SECTION 2 DISASSEMBLY



Reel Panel Removal



Bottom Plate Cover Removal

(The voltage on the mic amp board can be checked.)

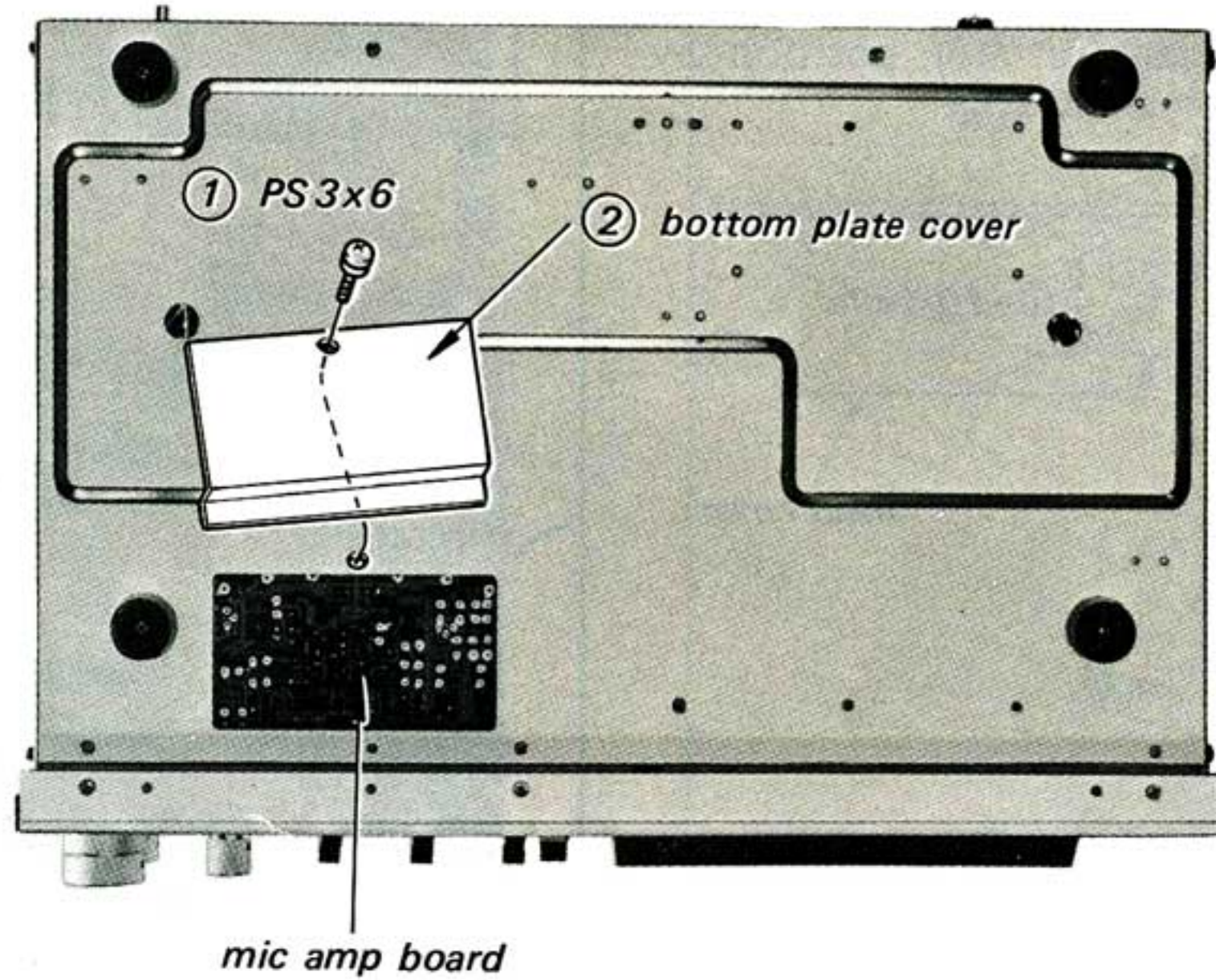

SECTION 3 ADJUSTMENTS

3-1. MECHANICAL ADJUSTMENTS

PRECAUTION

1. Clean the following parts with a denatured-alcohol-moistened swab:

record/playback head	pinch roller
erase head	rubber belts
capstan	idlers
2. Demagnetize the record/playback head with a head demagnetizer.
3. Do not use a magnetized screwdriver for the adjustments.
4. After the adjustments, apply a suitable locking compound to the parts adjusted.
5. The adjustments should be performed with the rated power supply voltage unless otherwise noted.

Test Tape L-9-MR (with a mirror) 8-918-064-15

section	1	2	3	4
frequency	315 Hz	7 kHz	12.5 kHz	3 kHz
level	0 dB	-10 dB	-10 dB	0 dB
time	40 sec.	60 sec.	40 sec.	180 sec.

Tape Path Adjustment (Use the test tape L-9-MR) — Playback mode —

1. Adjust the roller height by turning the screw so that the tape runs through the middle of the roller, and make sure that the roller smoothly rotates.

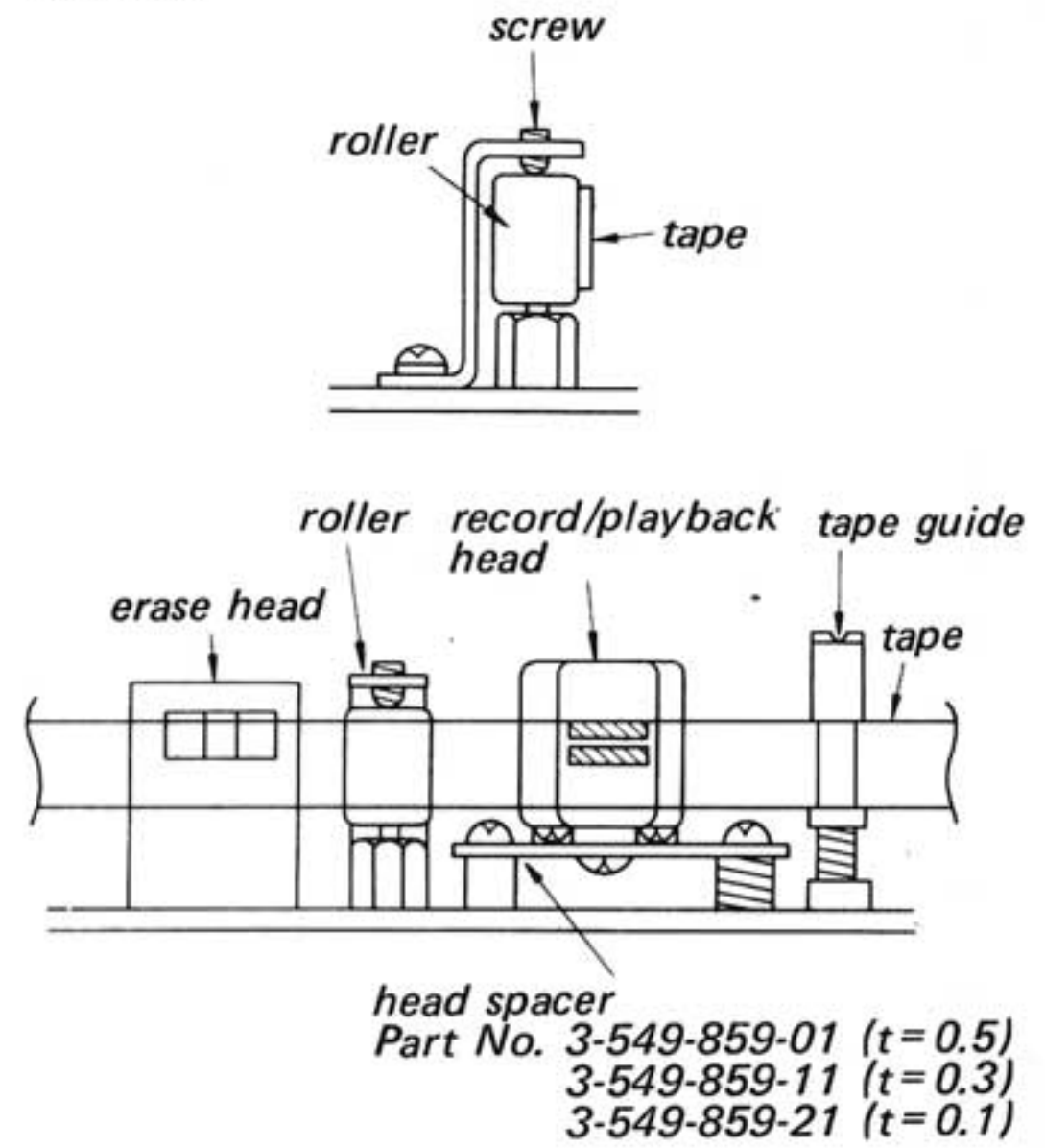

2. Adjust the tape guide height without tape curl.
3. Adjust the record/playback head height by head spacer so that the upper end of tape touches the upper end of core as shown below.

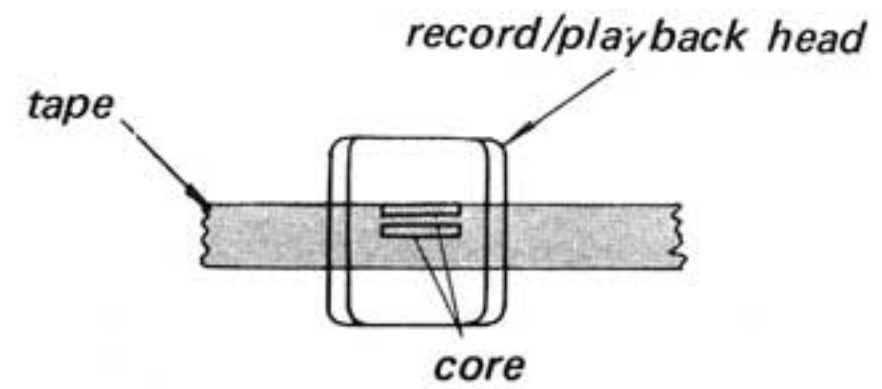

Tension Regulator Arm Position Adjustment — Playback mode —

Adjust the tension regulator arm position by loosening the screw.

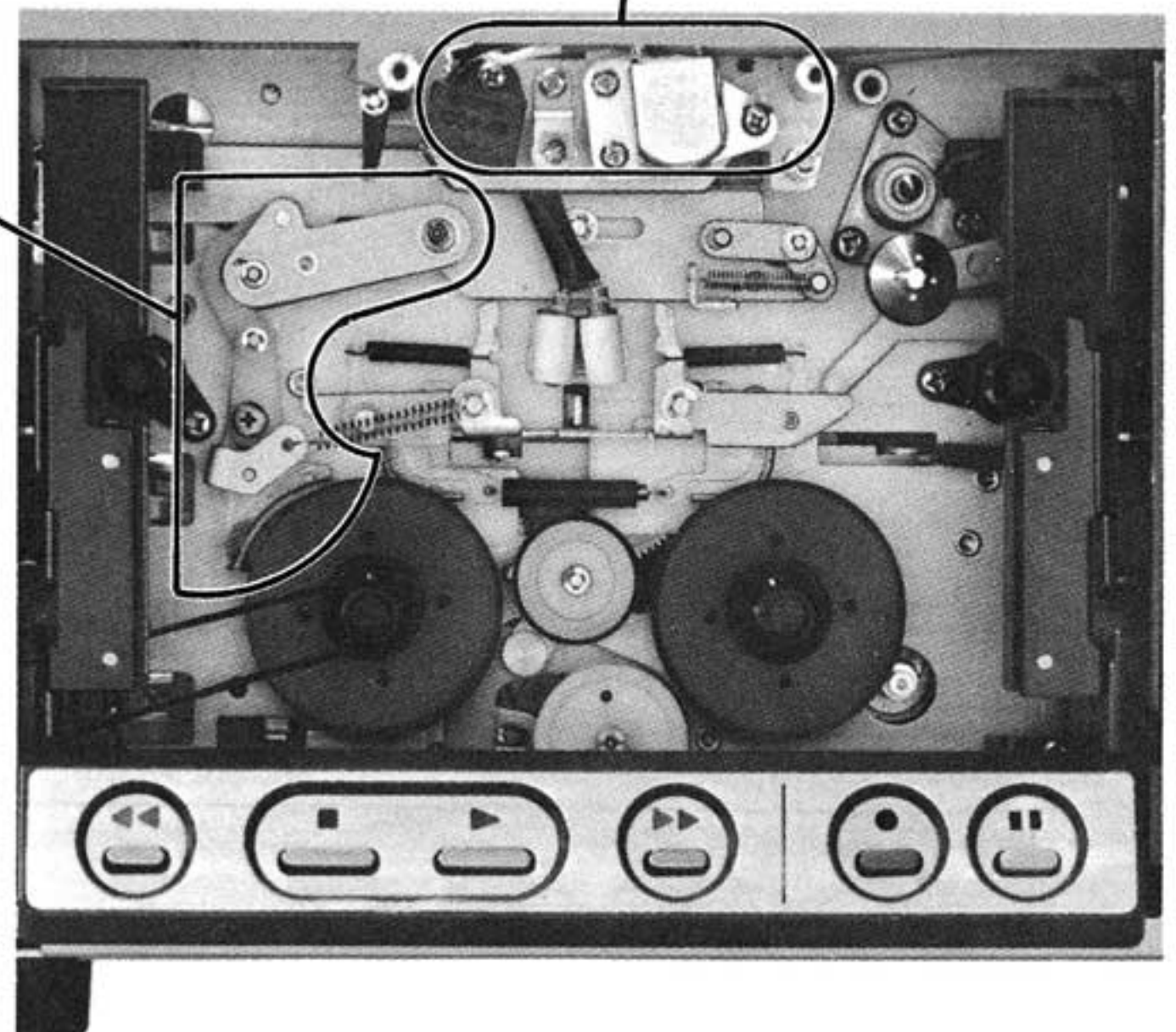
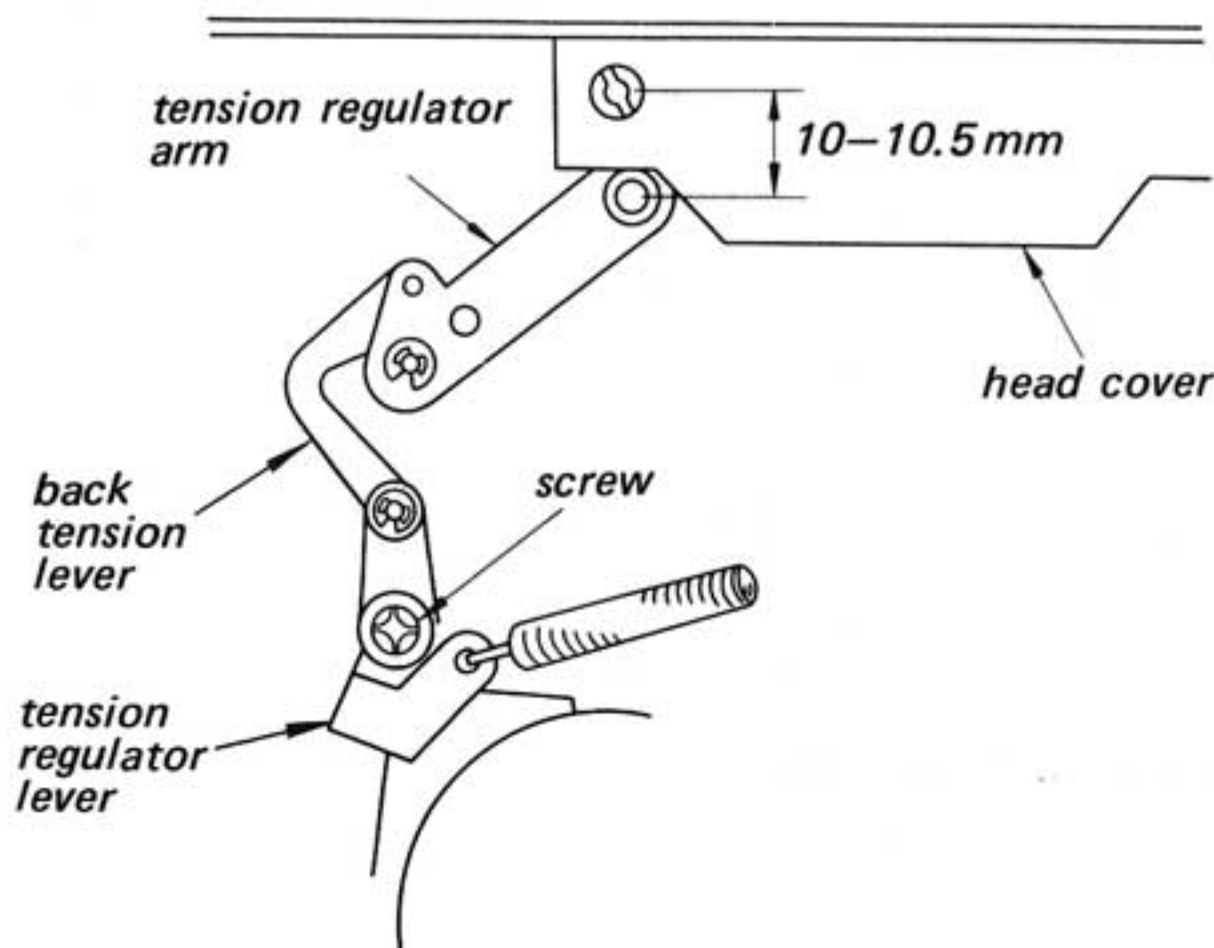

Pinch Roller Pressure Measurement

— Playback mode —

1. Set the tension gauge.
2. Push the tension gauge.
3. Slowly return the pinch roller and read the tension gauge just when the pinch roller starts to rotate.

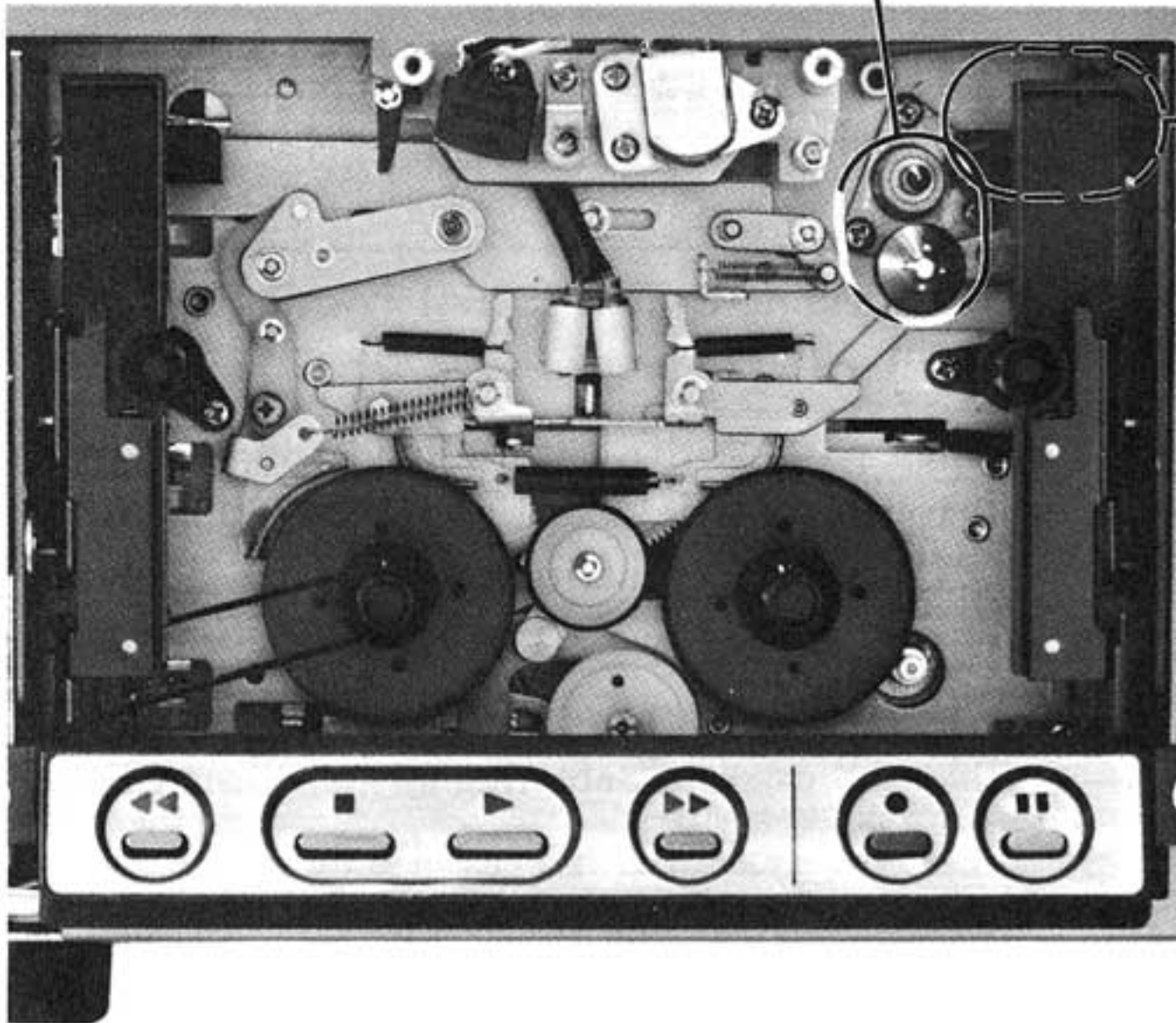
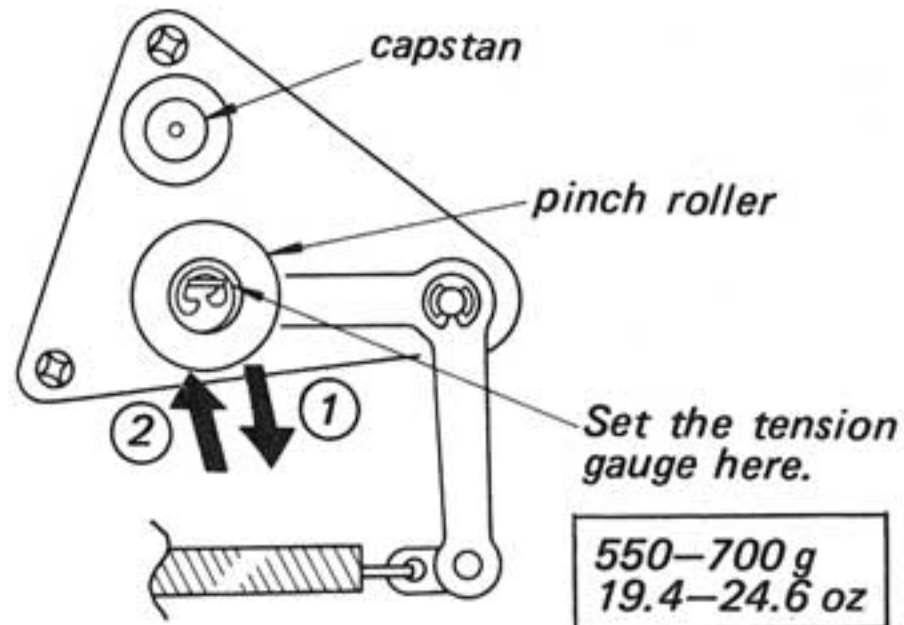

Tape Retaining Cam Position Adjustment

1. Insert the ELCASET into the cassette holder and press the cassette holder to position the tape retainer as shown in Fig. A. Then, loosen the screws in Fig. C and adjust the tape retaining cam position to obtain the specified clearances *1 and *2 in Fig. B.

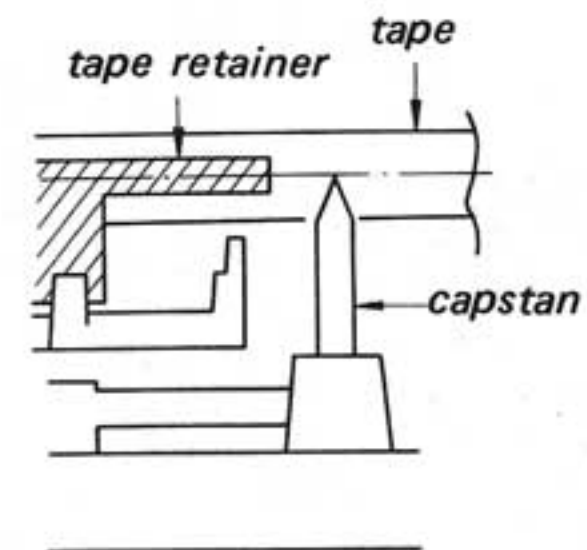

Fig. A

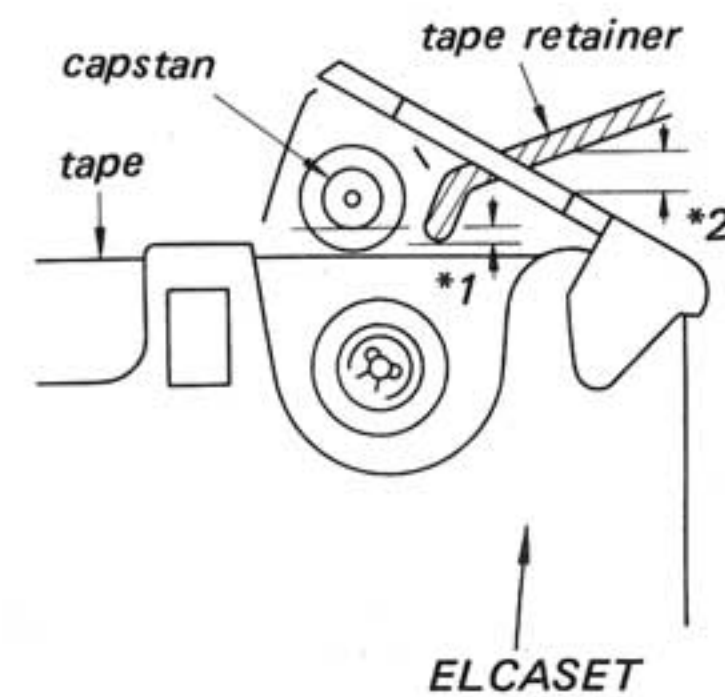

Fig. B

Specification:
clearance *1: 1-1.5 mm
clearance *2: more than 1 mm

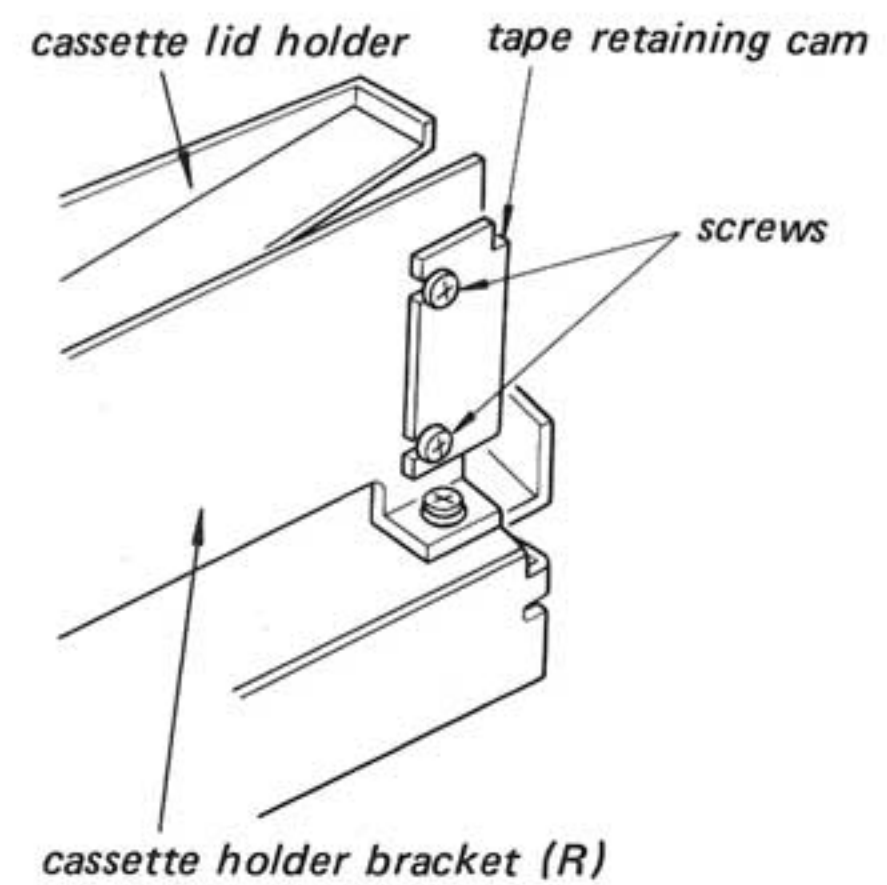
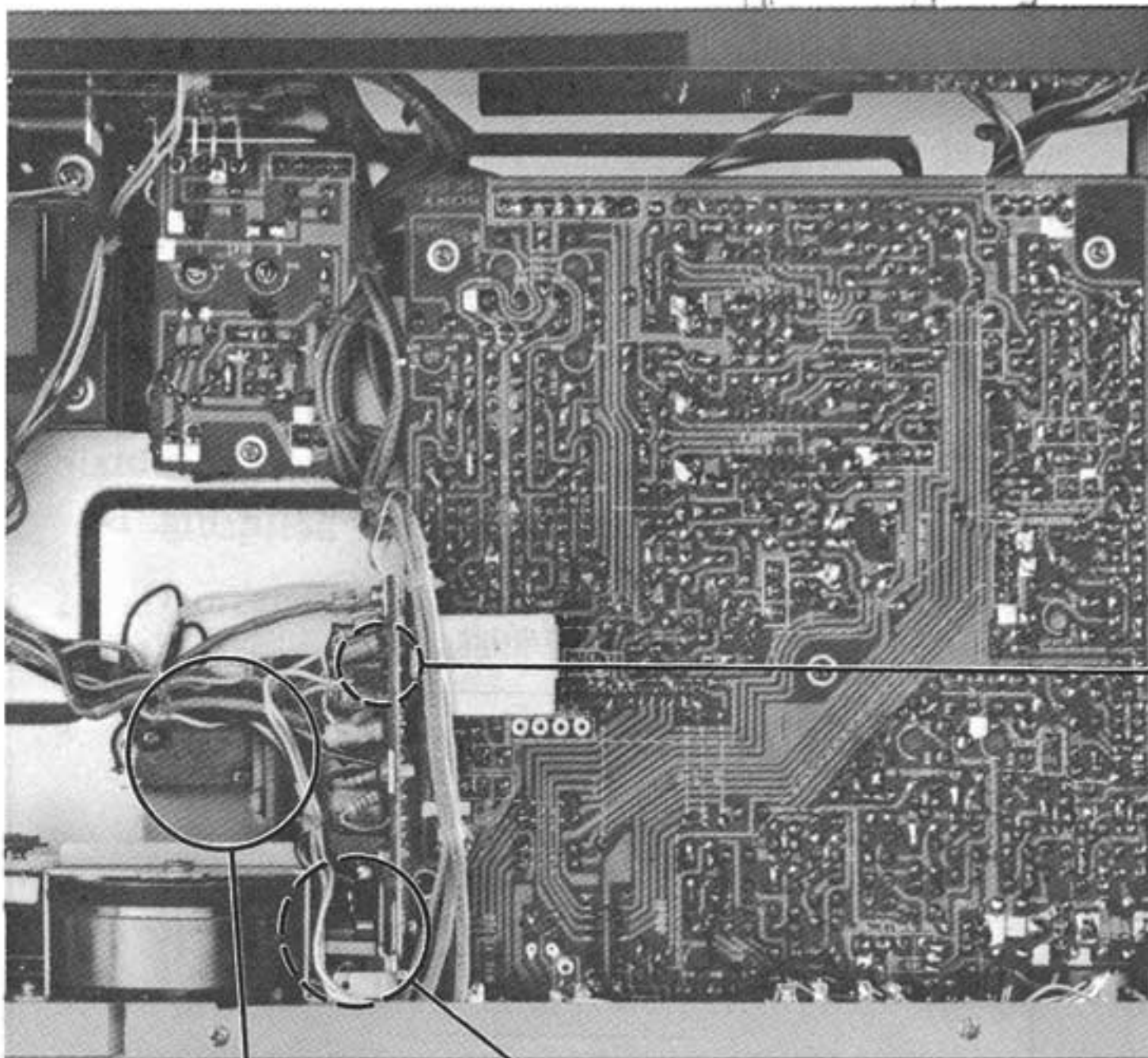

Fig. C

2. Push and lock the cassette holder in and make sure that the tape retainer does not touch the tape.



Record Slider Position Check

1. Install the ELCASET.
2. When pushing the record and forward buttons, make sure that the record switch lever completely pushes the record/playback switch (S1).
3. Make sure that the clearance exists between the record switch lever and the record slider.

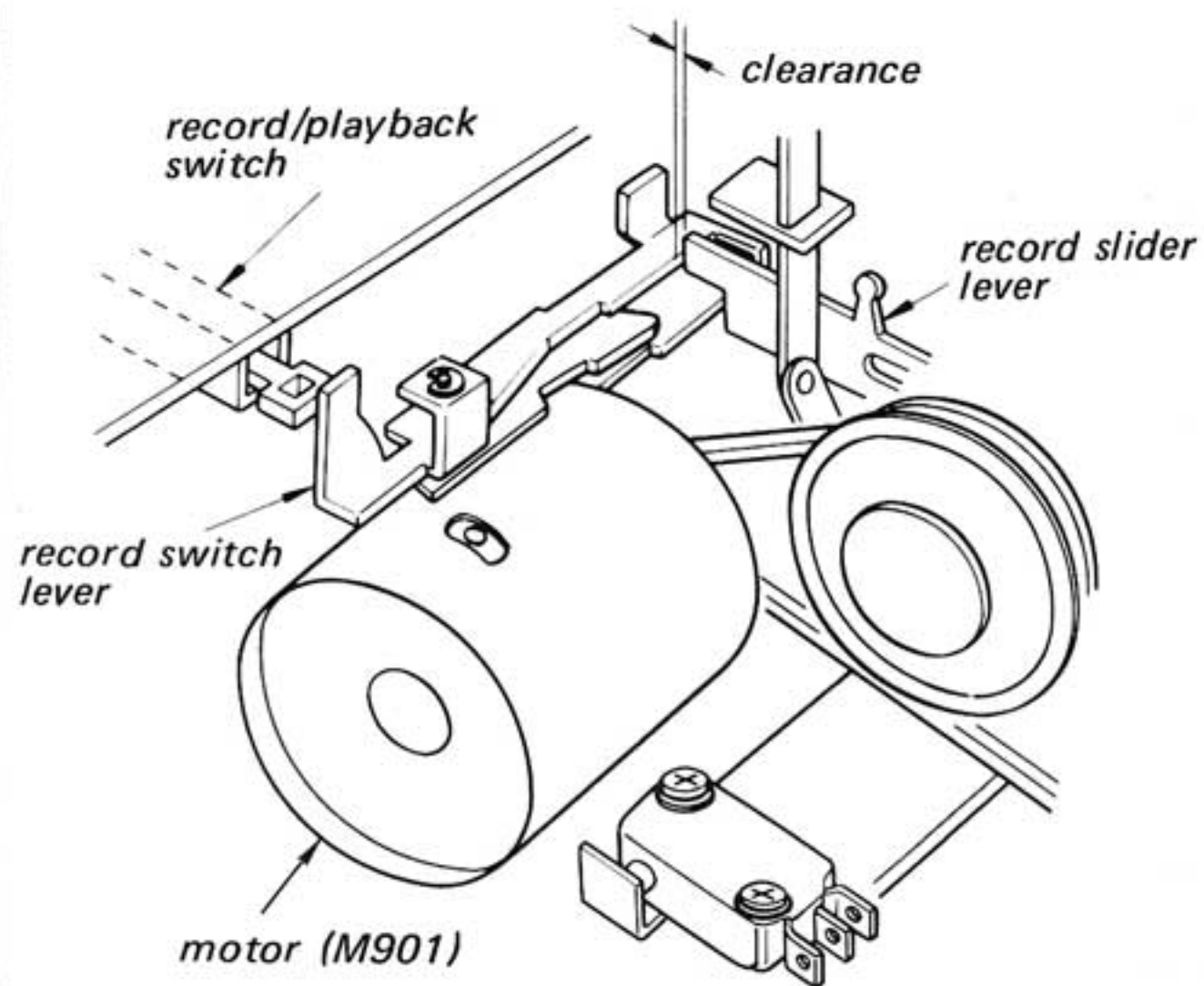

Erasure-proof Switch (S953) Position Adjustment

1. When installing the ELCASET whose erasure-proof tab does not slide in, make sure that the erasure-proof switch (S953) is ON.
2. When installing the ELCASET whose erasure-proof tab slides in, make sure that the erasure-proof switch (S953) is OFF.
3. If necessary, adjust the erasure-proof switch position by loosening the screw.

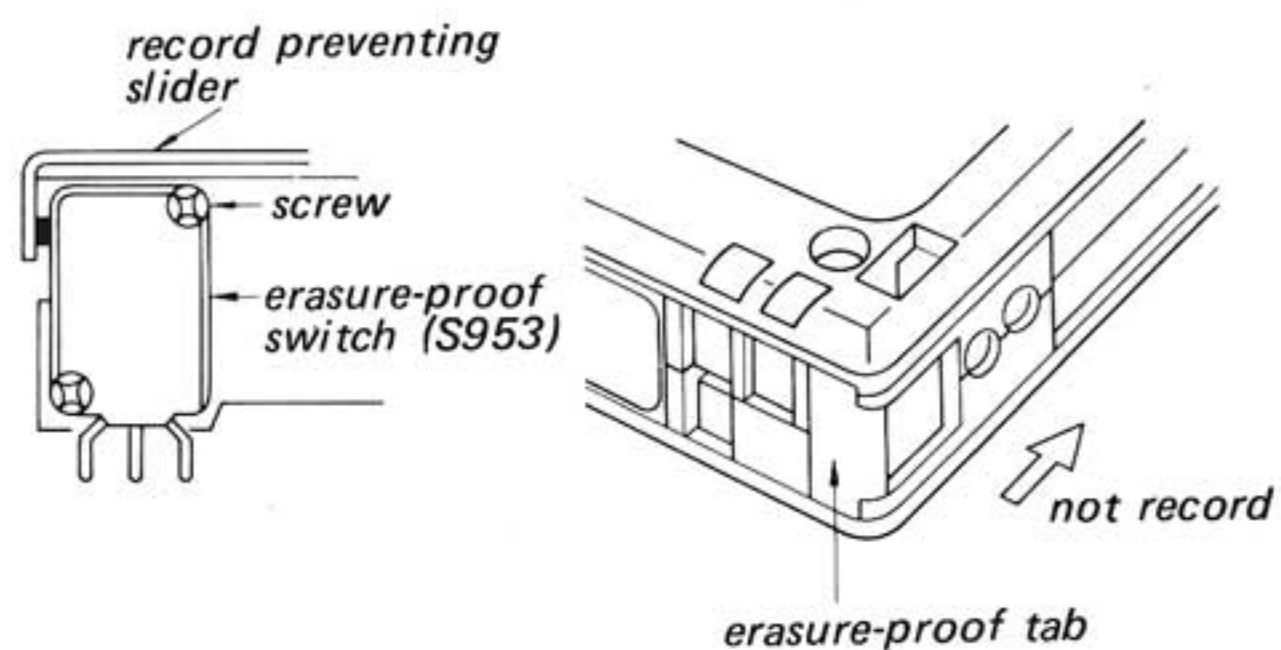

Cassette Detecting Switch (S954) Position Adjustment

1. When pushing the cassette holder in, make sure that the cassette detecting switch (S954) turns ON and the reduction speed slider does not cross the cassette detecting switch over.
2. When ejecting the cassette holder, make sure that the cassette detecting switch turns OFF.
3. If necessary, adjust the cassette detecting switch position by loosening the screw.

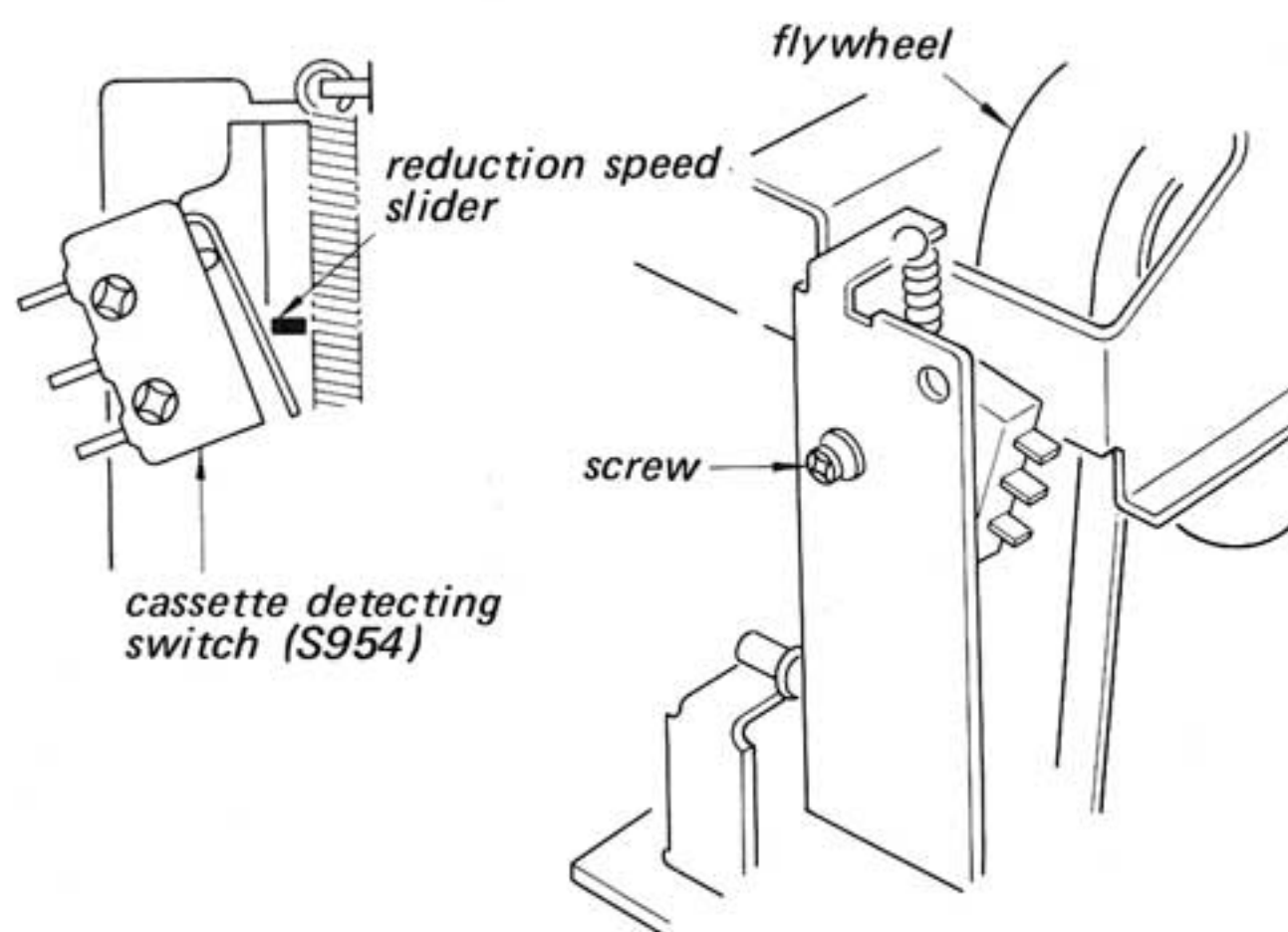

Brake Torque Adjustment

— Stop mode —

Direction	Torque meter reading
(A)	250–300 g.cm (3.5–4.1 oz.in)
(B)	30–40 g.cm (0.42–0.55 oz.in)

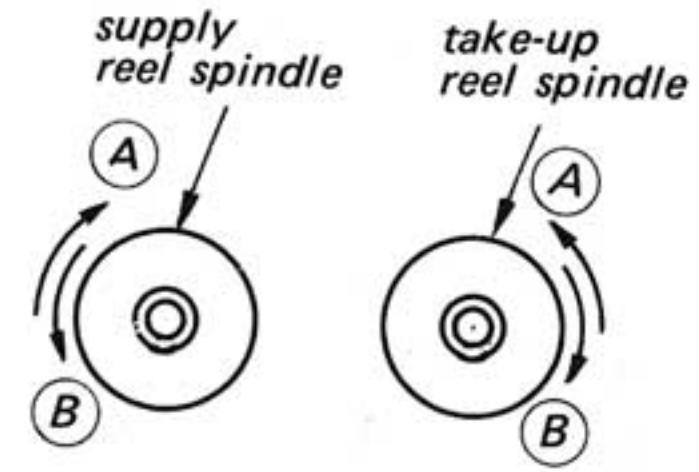

If necessary, change the spring position.

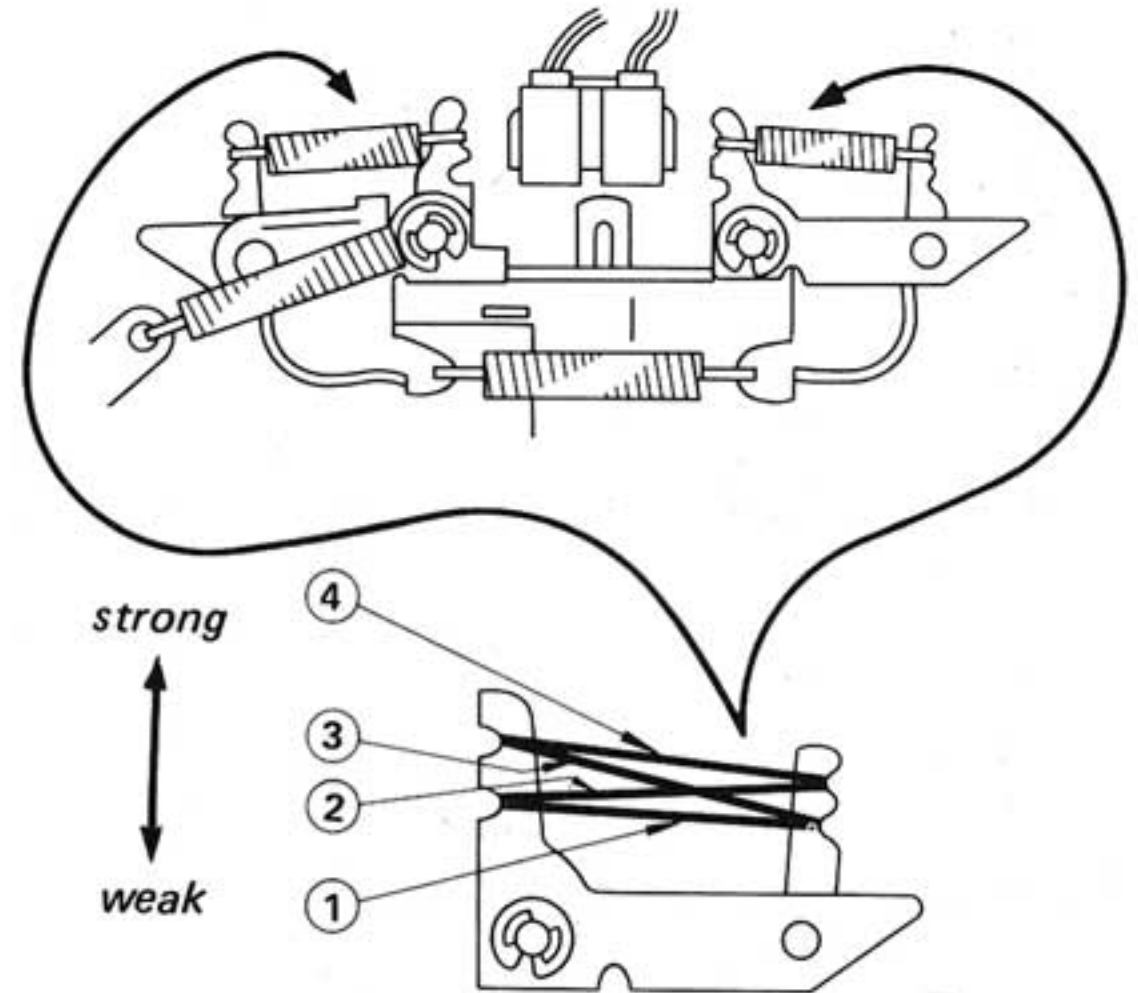
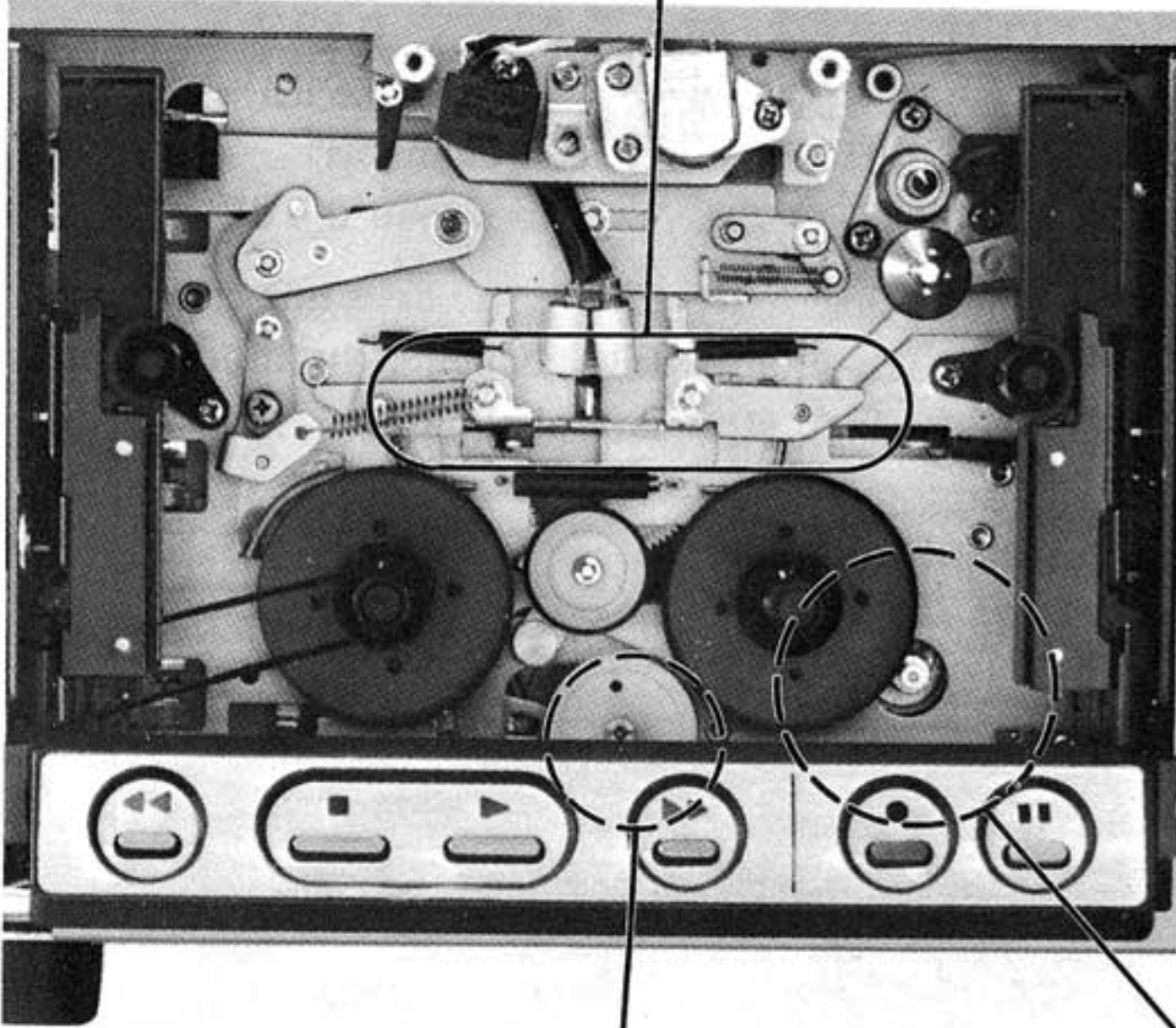

Fast Forward and Rewind Torque Adjustment

— Fast forward or rewind mode —

Torque meter	Meter reading
CQ-201L	200–250 g.cm (2.8–3.4 oz.in)

1. Change the spring position.
2. If necessary, change the fast forward pulley height.

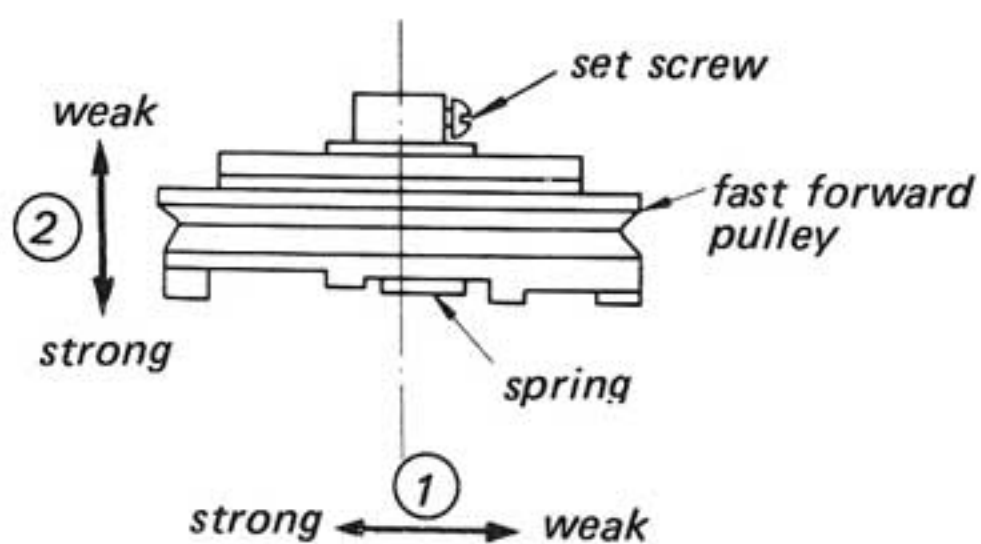

Forward Torque Adjustment

— Playback mode —

Torque meter	Meter reading
CQ-101L	90–120 g.cm (1.25–1.66 oz.in)

If necessary, change the spring position.

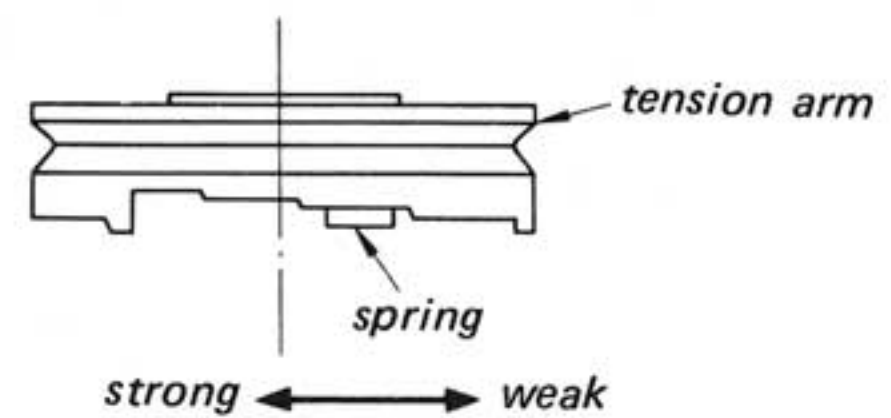

Back Tension Torque Measurement

— Playback mode —

Torque meter	Meter reading
CQ-101L	65–100 g.cm (0.91–1.38 oz.in)

3-2. ELECTRICAL ADJUSTMENTS

Note: The adjustments should be performed in the order given in this service manual. The adjustments should be performed for both L-CH and R-CH.

Switches and controls should be set as follows unless otherwise specified.

POWER switch:	ON
TIMER switch:	OFF
MEMORY switch:	OFF
DOLBY NR switch:	OFF
MPX FILTER switch:	OFF
TAPE SELECT EQ switch:	TYPE I
TAPE SELECT BIAS switch:	TYPE I
LEVEL ADJUST control:	fully clockwise (on the rear panel)

BIAS and EQ switch settings in accordance with tape used are as follows.

Blank Tape	EQ switch	BIAS switch
CS-60 (SLH)	TYPE I	TYPE I
CS-70 (DUAD)	TYPE II	TYPE II

Standard Record

Set the REC LEVEL-LINE control for the specified output level. (REC LEVEL-MIC control: 0 position).

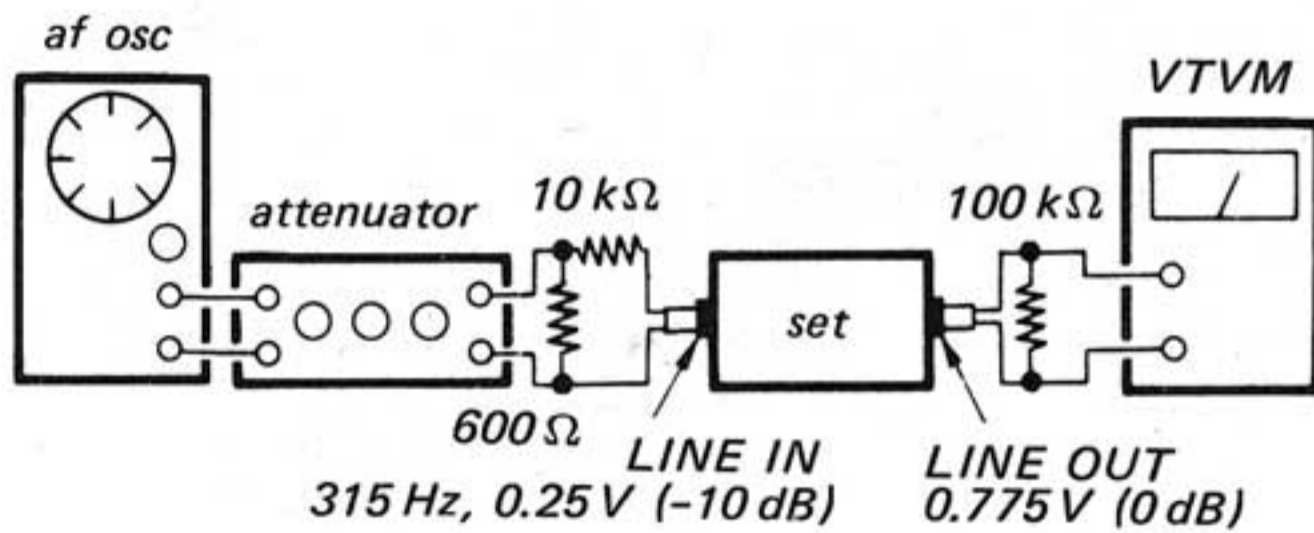

Standard Input Level

	MIC	LINE IN
source impedance	300 Ω	10 kΩ
input level	0.77 mV (-60 dB)	0.25 V (-10 dB)

Standard Output Level

	LINE OUT	HEADPHONES
load impedance	100 kΩ	8 Ω
output level	0.775 V (0 dB)	0.12 V (-16 dB) (PHONES LEVEL: fully clockwise)

DC Voltage Adjustment

Procedure:

Adjust RV701 and RV702 for specific VOM readings.

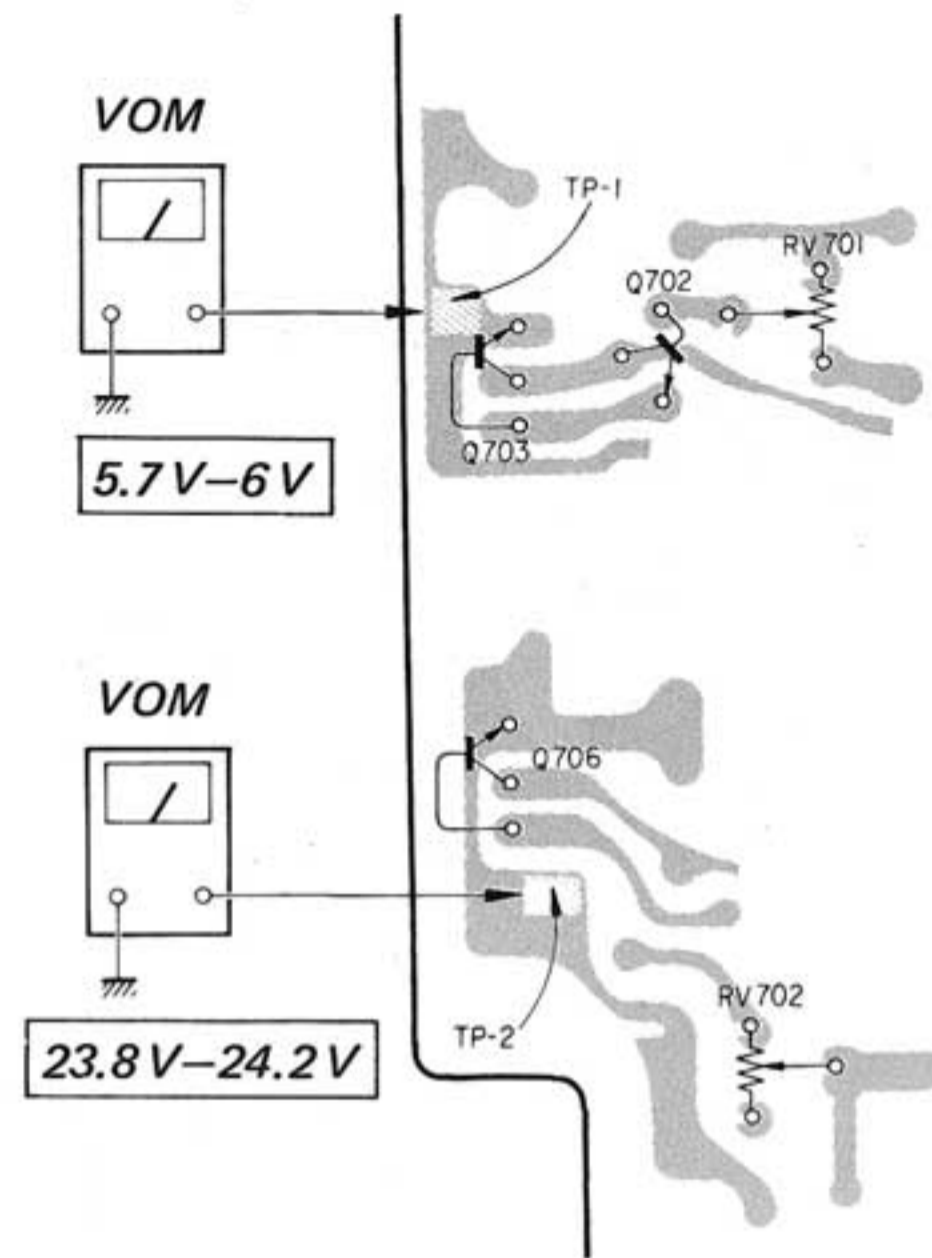

Adjustment Location:

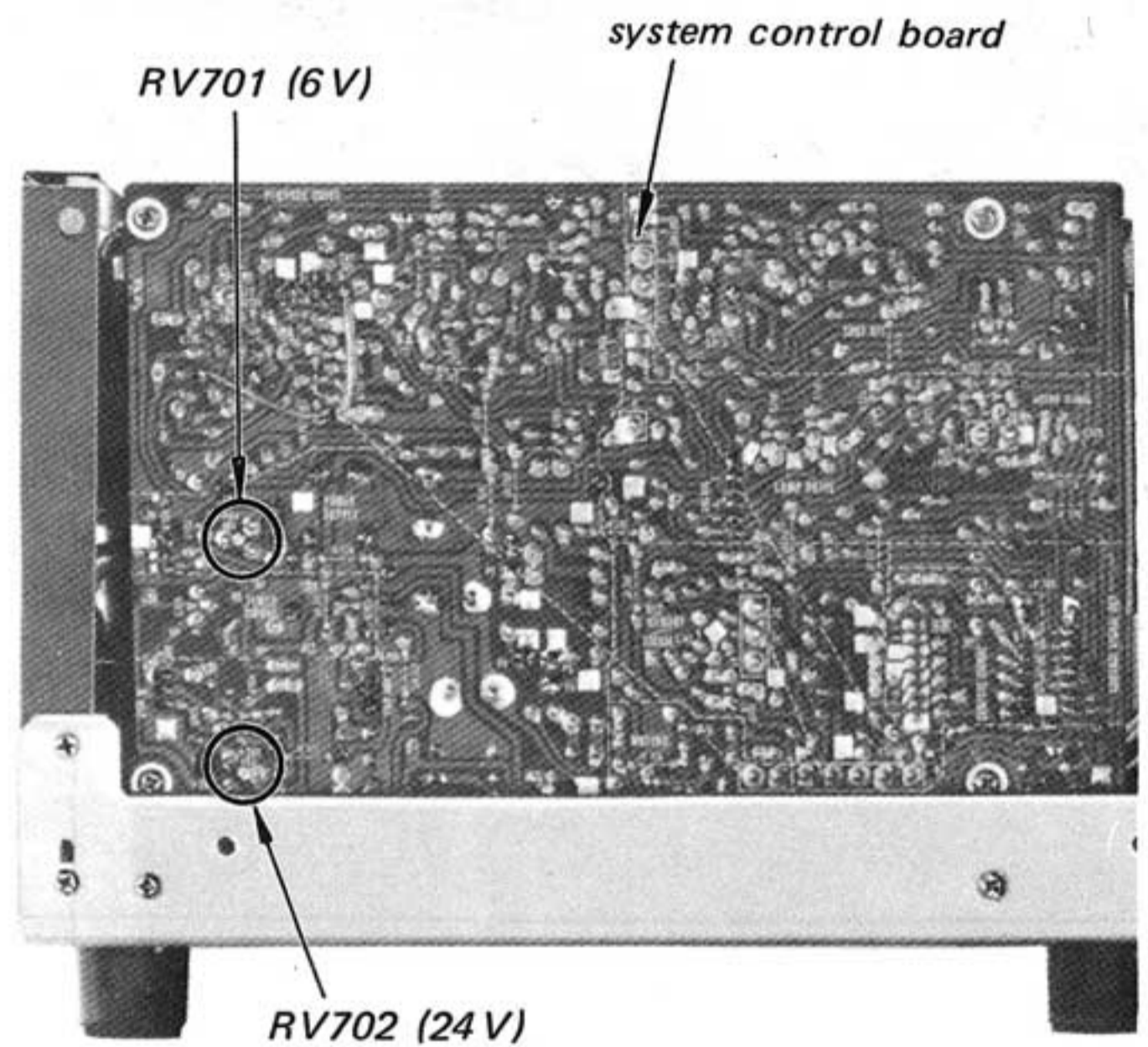

Auto Shut-off Voltage Adjustment

Procedure:

1. Play back the leader tape portion of test tape.
2. Adjust RV703 for the specified VOM reading.

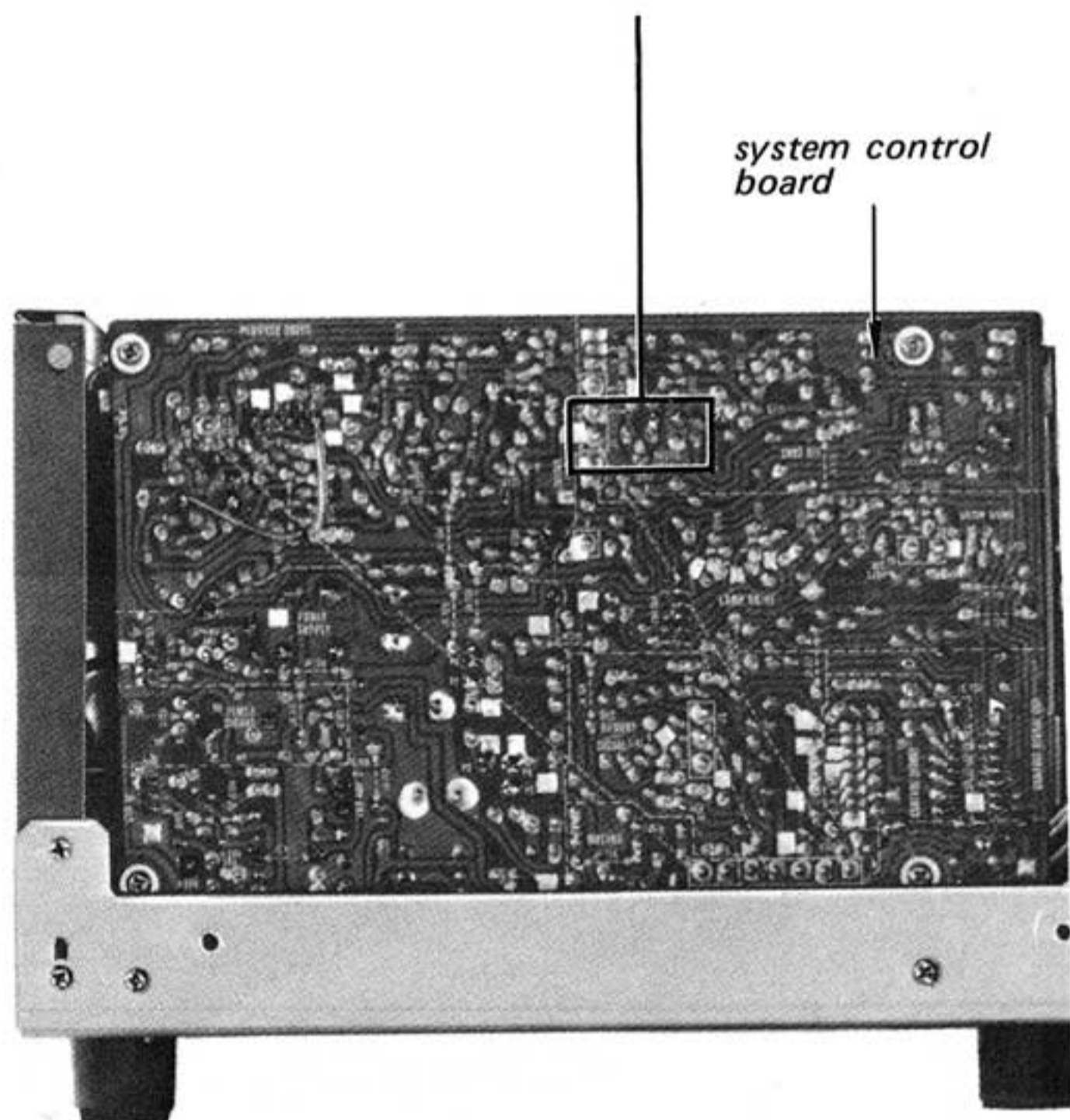
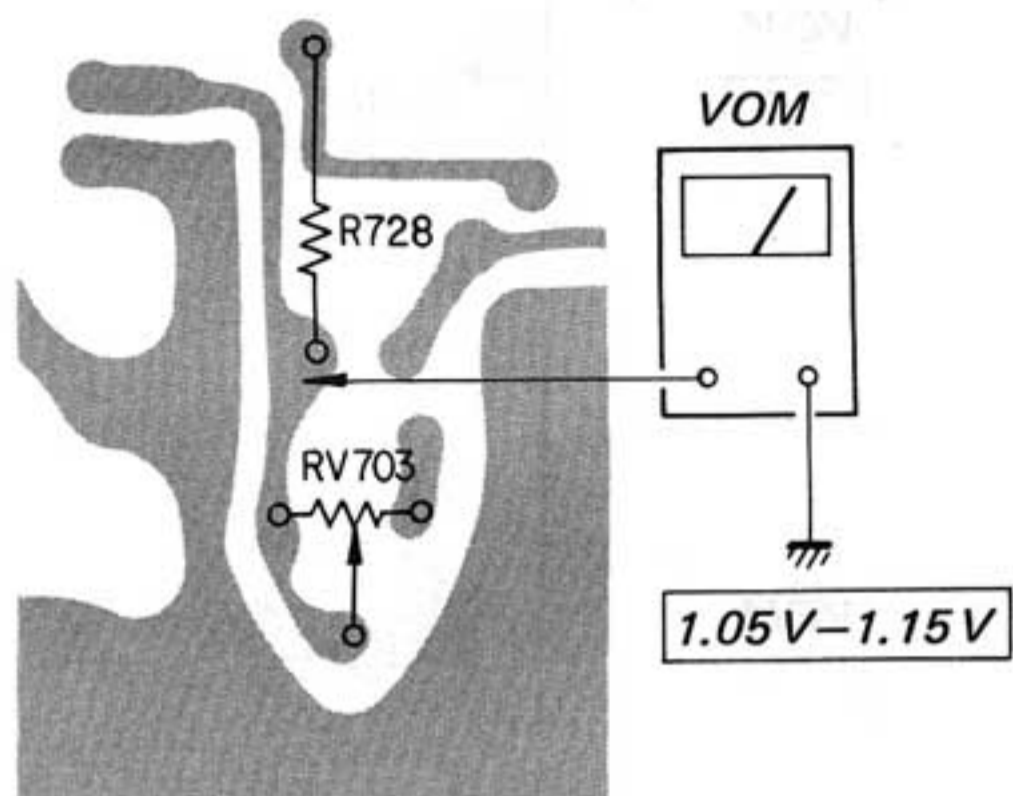

Tape Speed Adjustment

Procedure:

Mode: playback

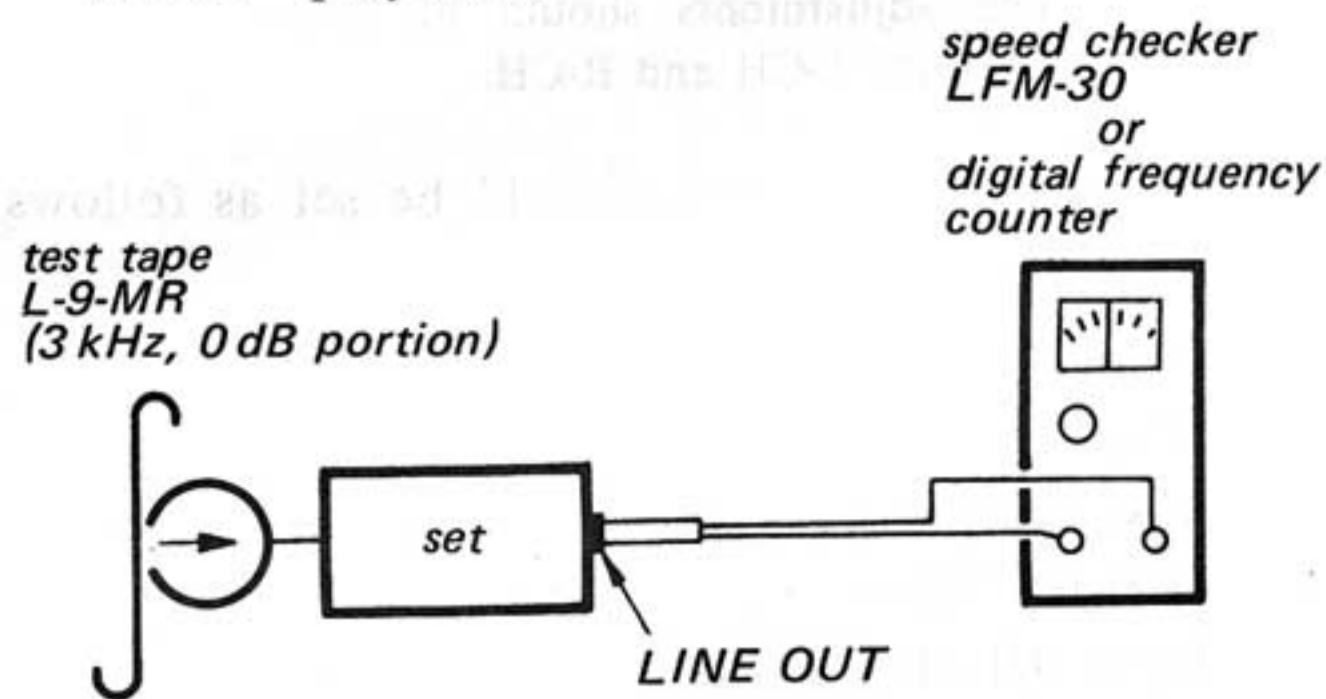

Specification:

Speed checker	Digital frequency counter
$\pm 0.65\%$	2,980–3,020 Hz

Adjustment Location:

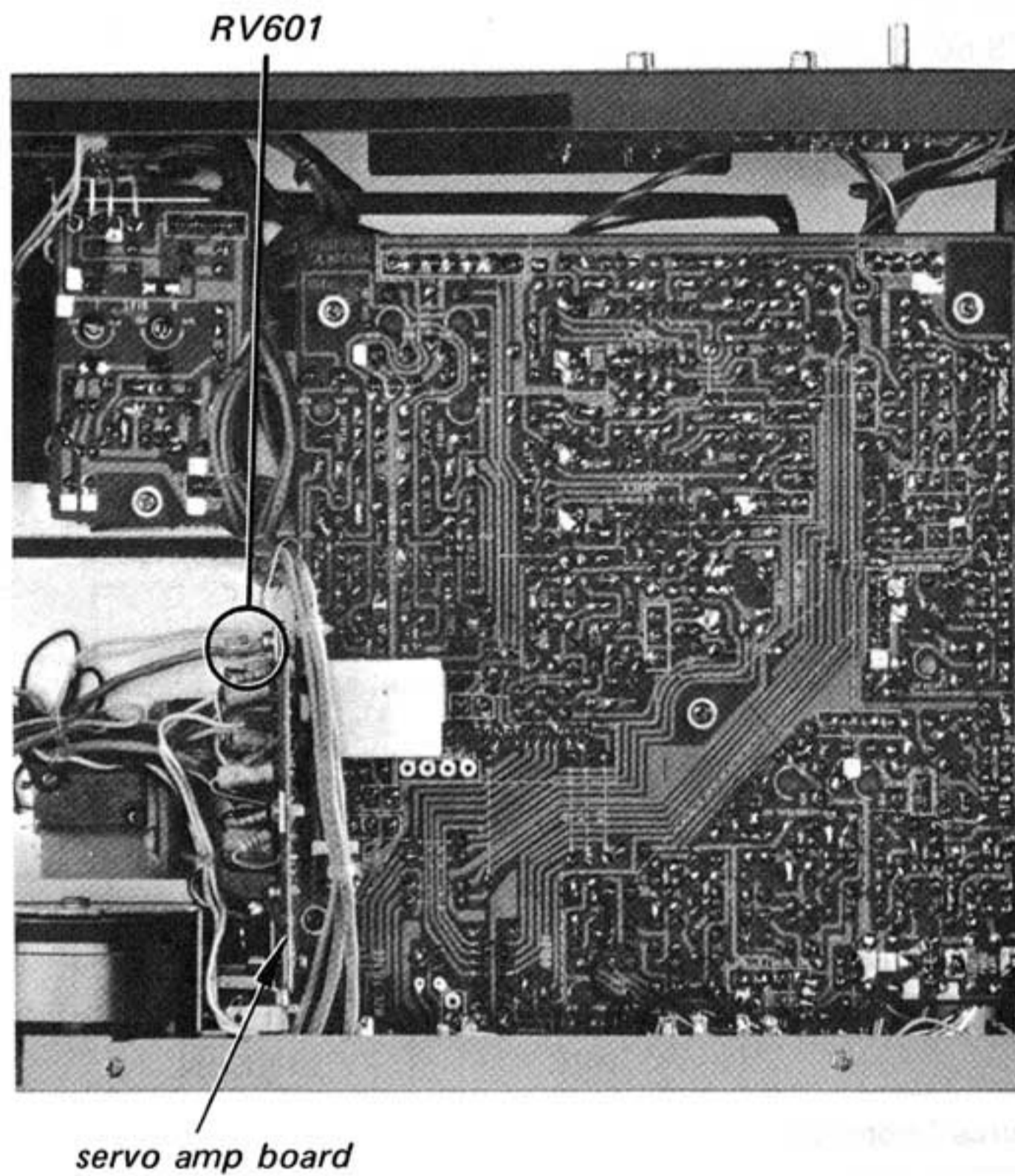

Record/playback Head Azimuth Adjustment

Procedure:

1. Mode: playback

test tape
L-9-MR
(7 kHz, -10 dB portion)

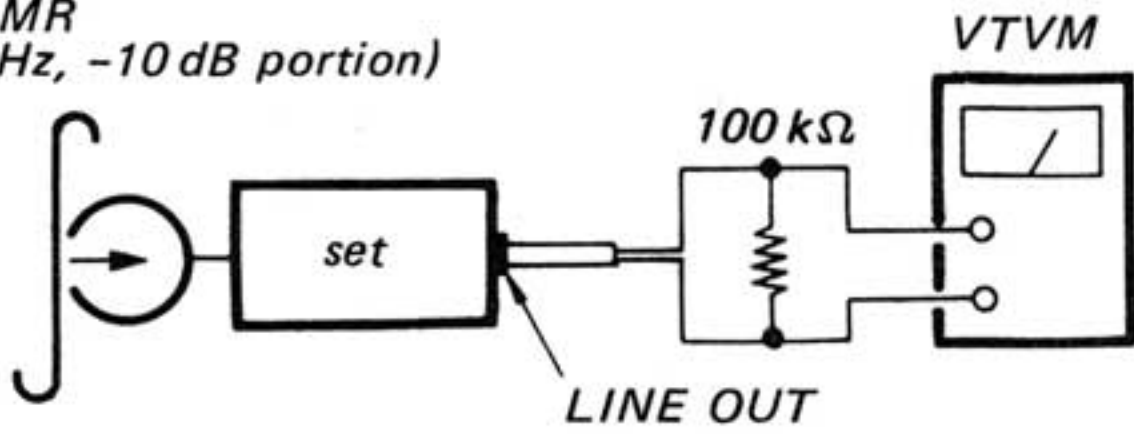

2. Turn the adjustment screw for the maximum level and set it to the mechanical mid position between L-CH and R-CH peak positions.

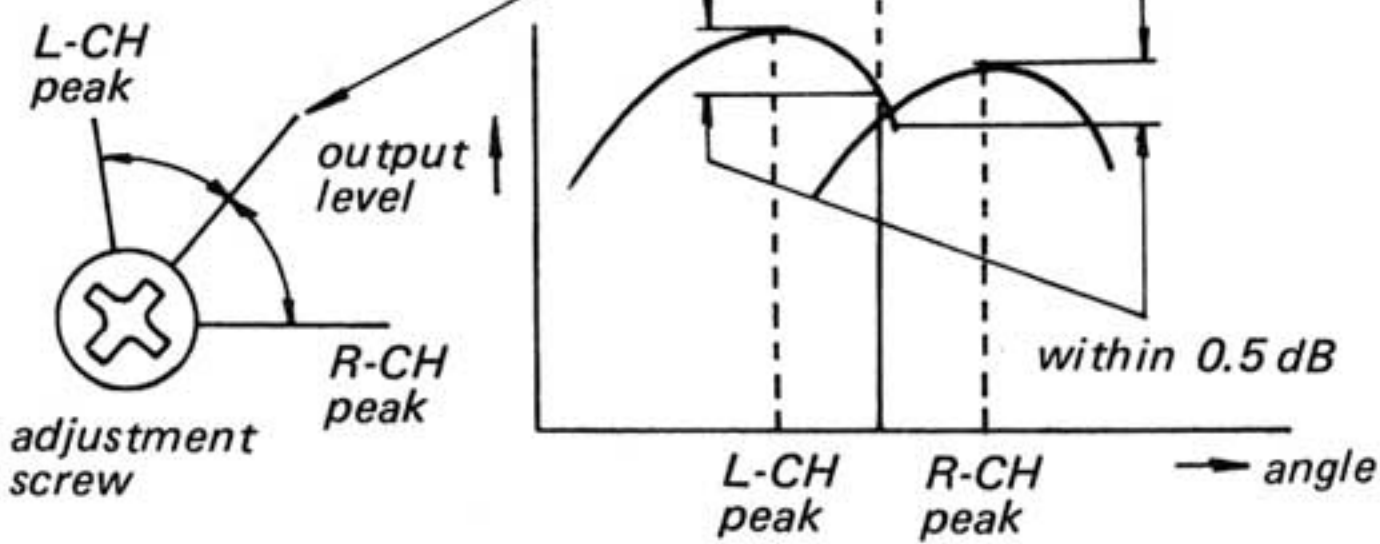

3. Mode: playback

L-9-MR
(7 kHz, -10 dB portion)

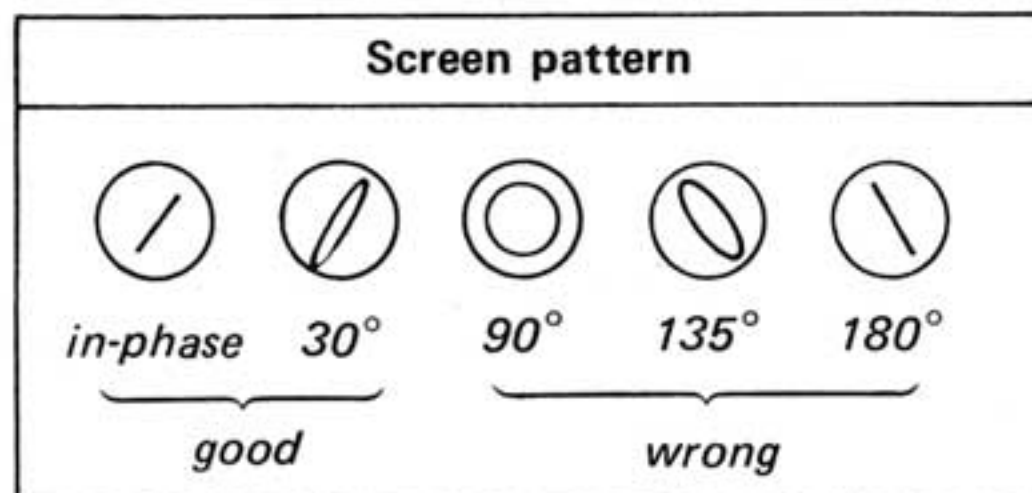
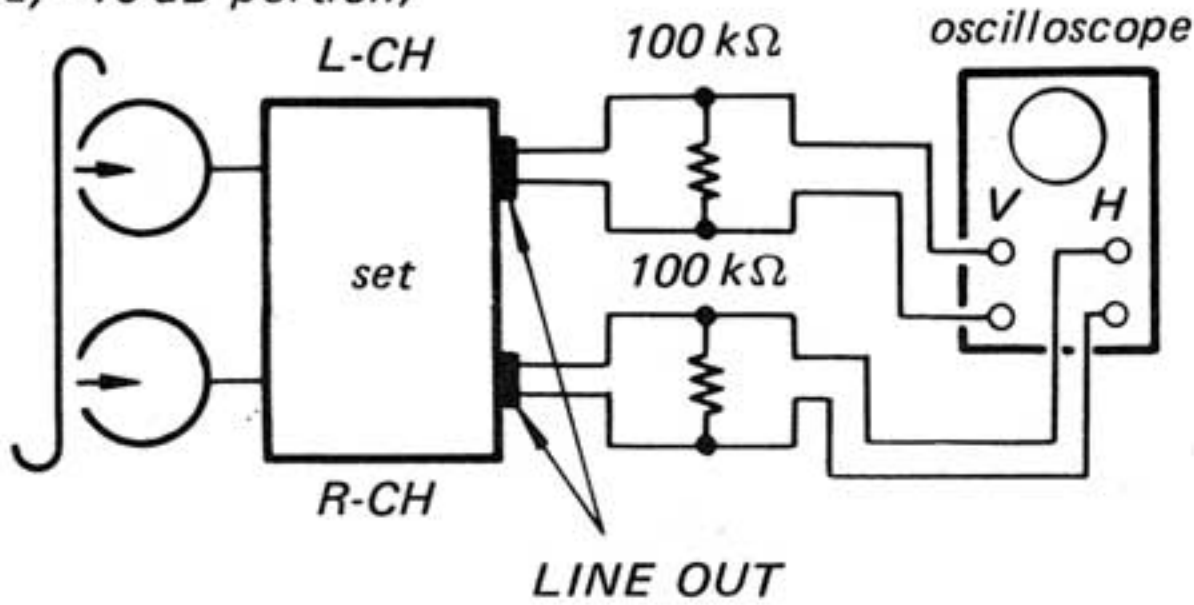

Adjustment Location:

(without head cover)

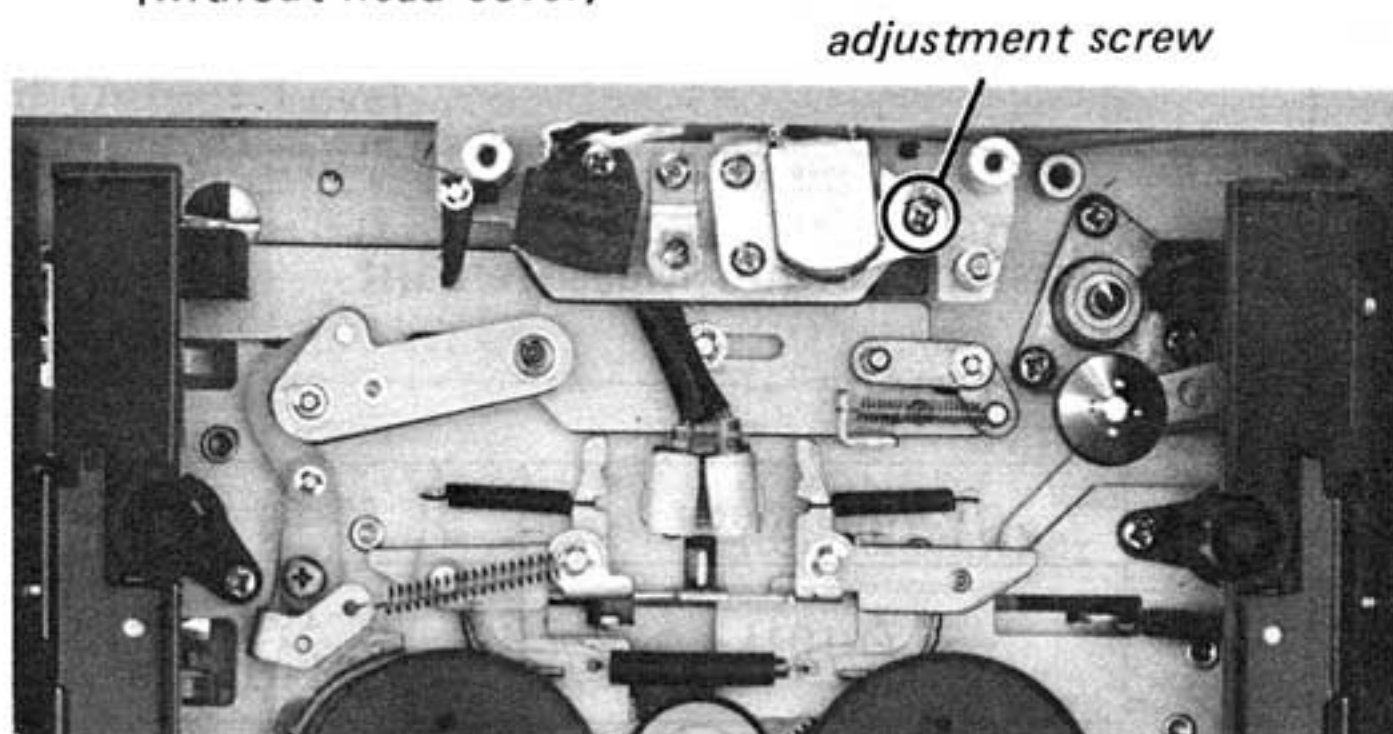

Playback Level Adjustment

Procedure:

Mode: playback

test tape
L-9-MR
(315 Hz, 0 dB portion)

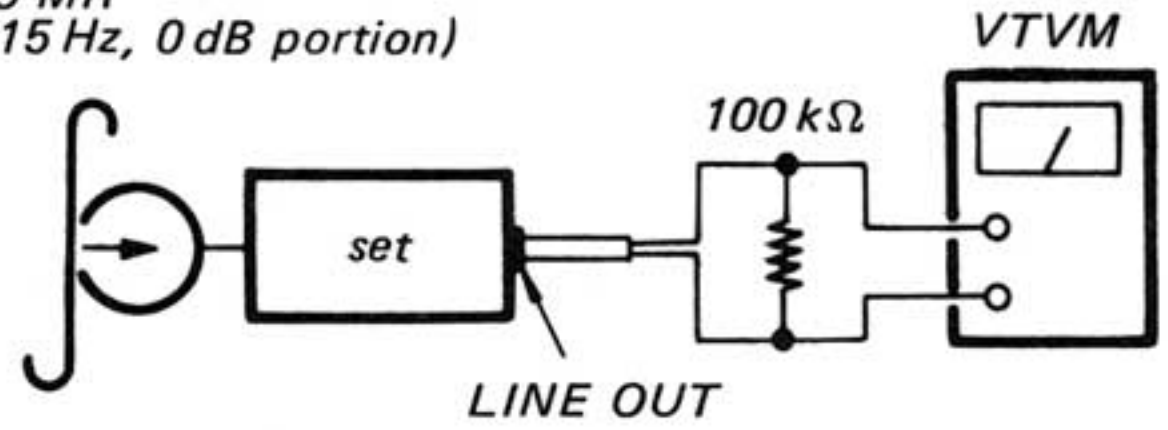

Specification:

LINE OUT Level: 0.73 V–0.89 V
(0 dB ± 0.5 dB)

Level difference between channels:
less than 0.5 dB

Check that LINE OUT level does not change in playback mode while changing the mode from playback to stop several times.

Adjustment Location:

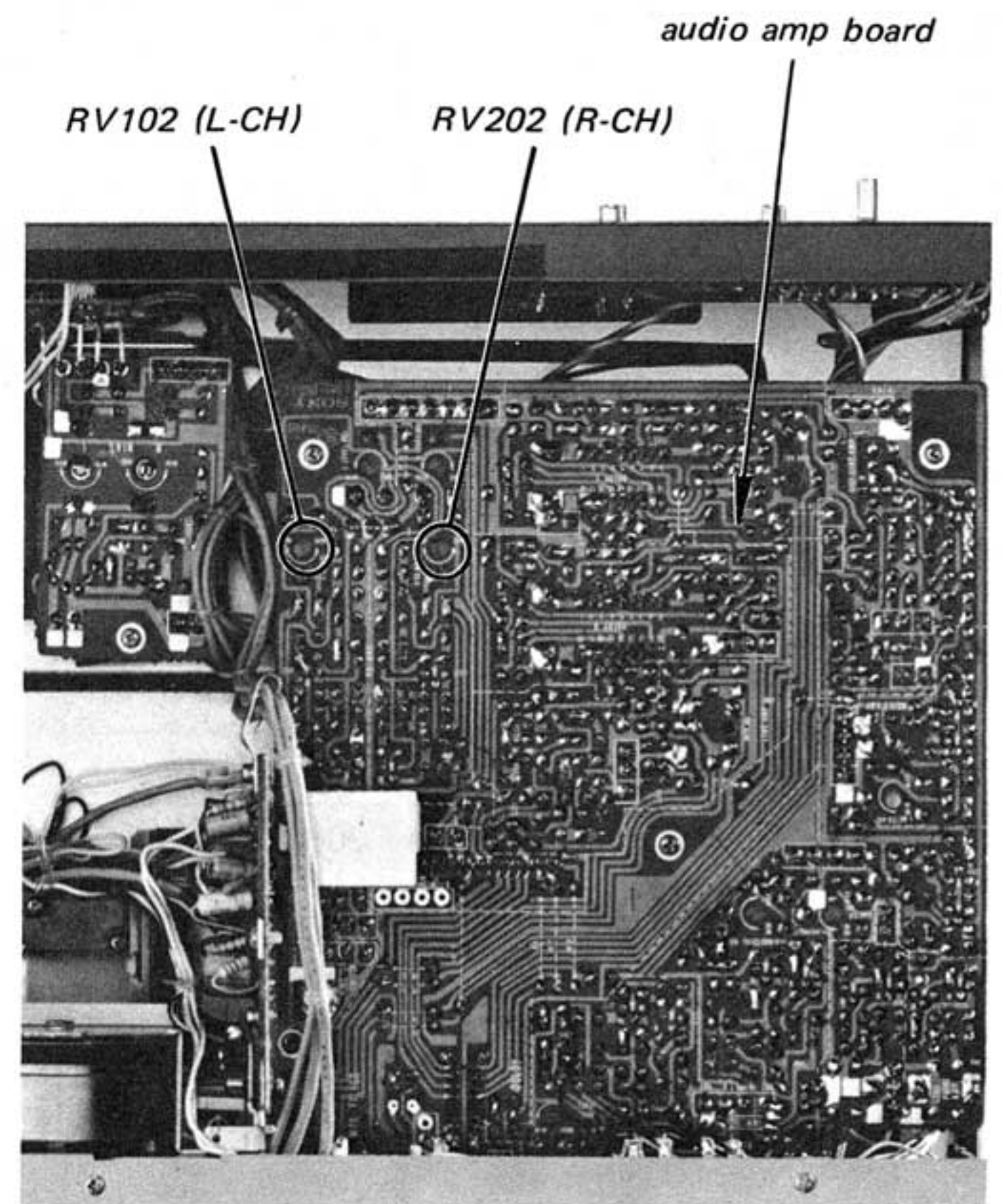

Playback Equalizer Adjustment

Procedure:

Mode: playback

test tape
L-9-MR
(315 Hz, 0 dB and
7 kHz, -10 dB portion)

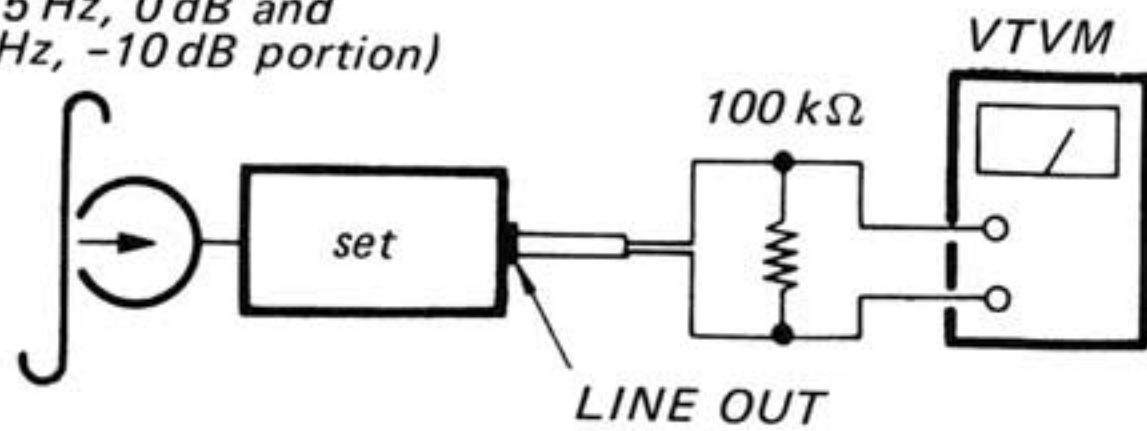

Specification:

7 kHz level difference from 315 Hz:
-10 dB ± 0.5 dB

Note: After the playback equalizer adjustment make sure that 315 Hz level is between 0.73 V and 0.89 V (0 dB ± 0.5 dB).

Adjustment Location:

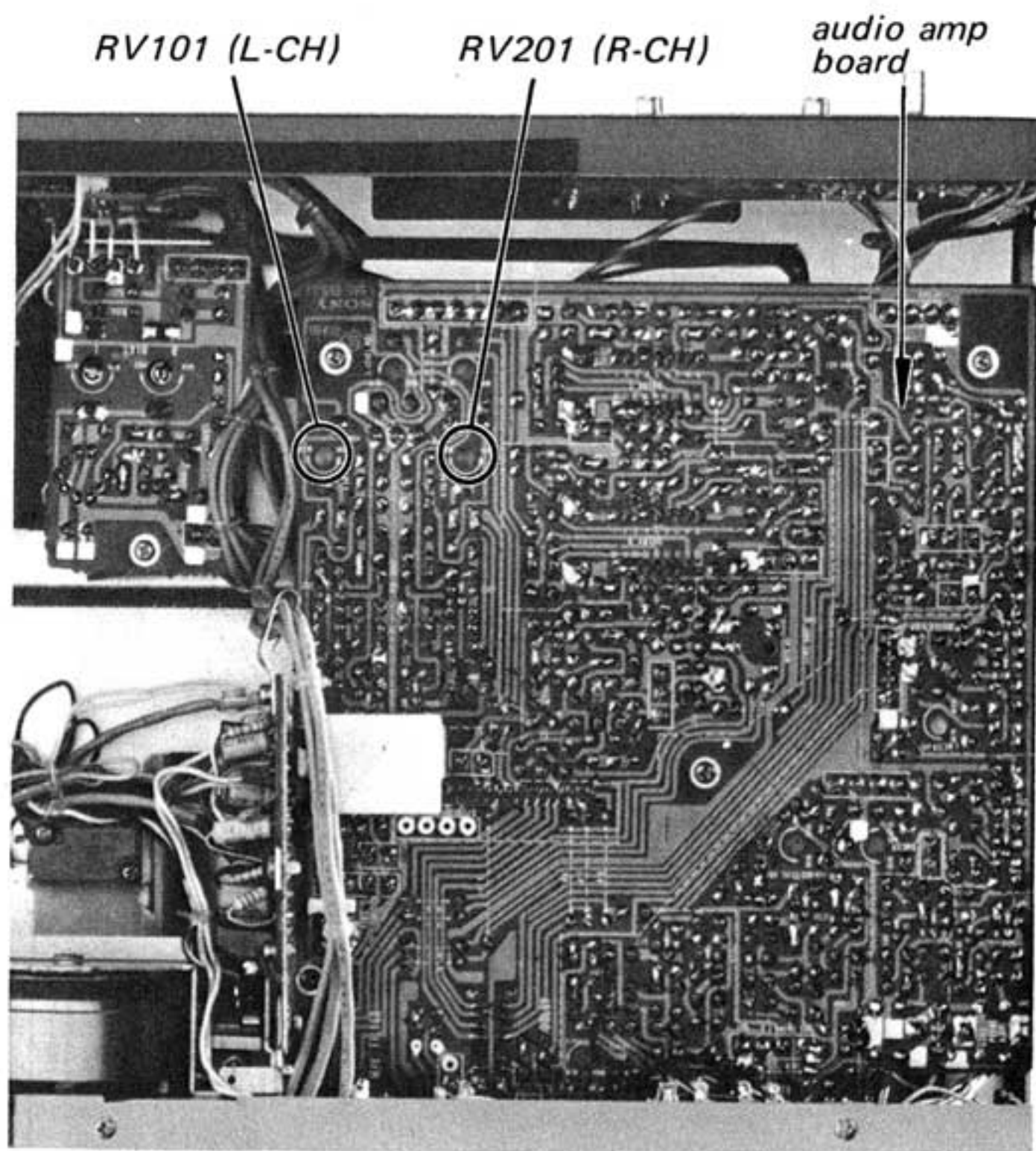

Level Meter Calibration

Setting:

REC LEVEL-LINE control: standard record
(See page 20)

Procedure:

1. Mode: record

af osc

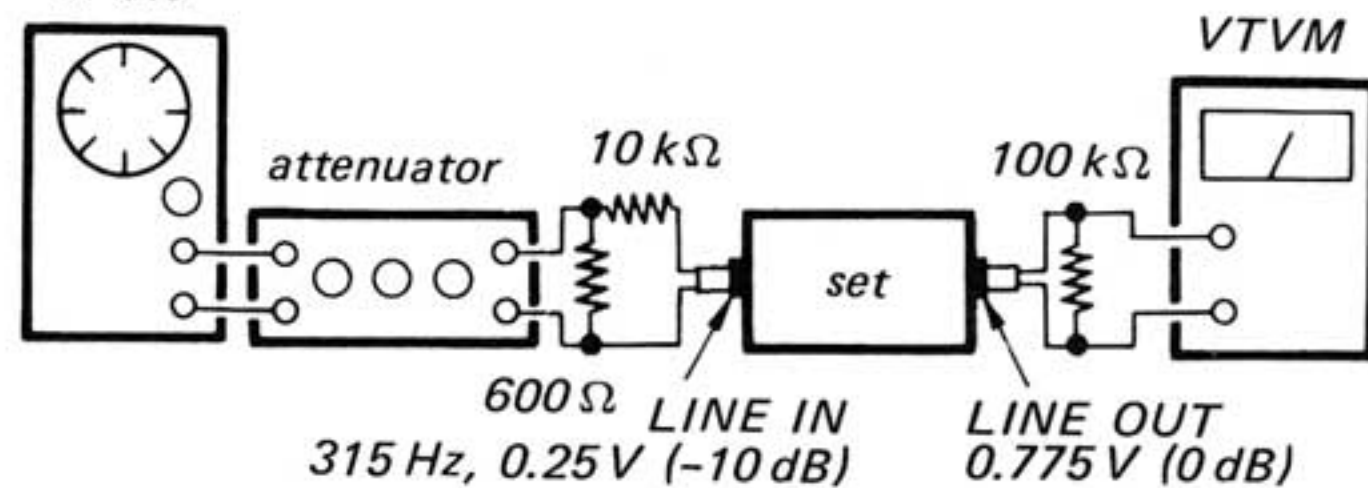

2.

Adjust	VU Meter indication
RV103 (L-CH)	
RV203 (R-CH)	

Adjustment Location:

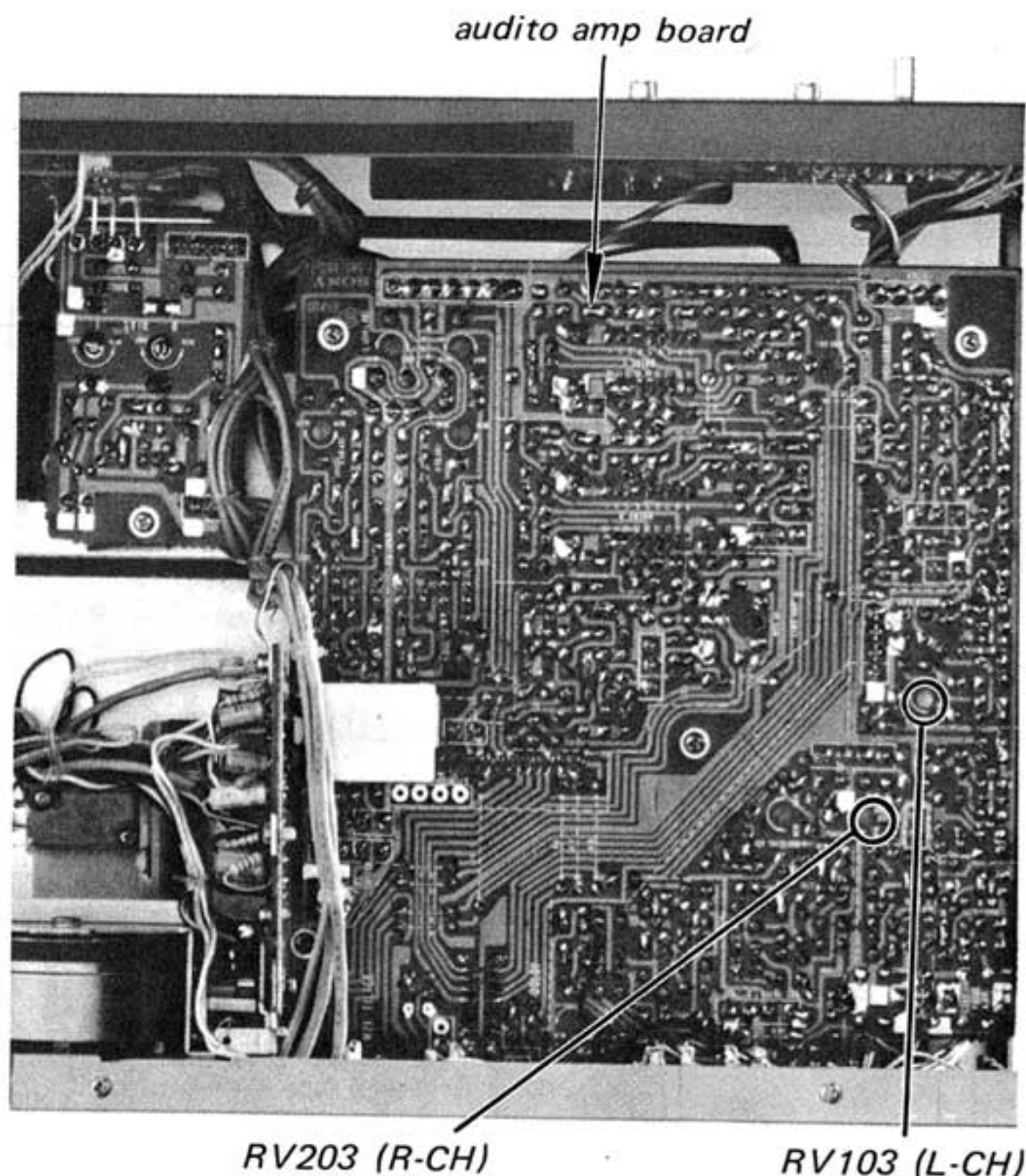

Note: The pointer should move smoothly.

Record Bias Adjustment

Setting:

REC LEVEL-LINE control: standard record
(See page 20.)

Procedure:

1. Mode: record

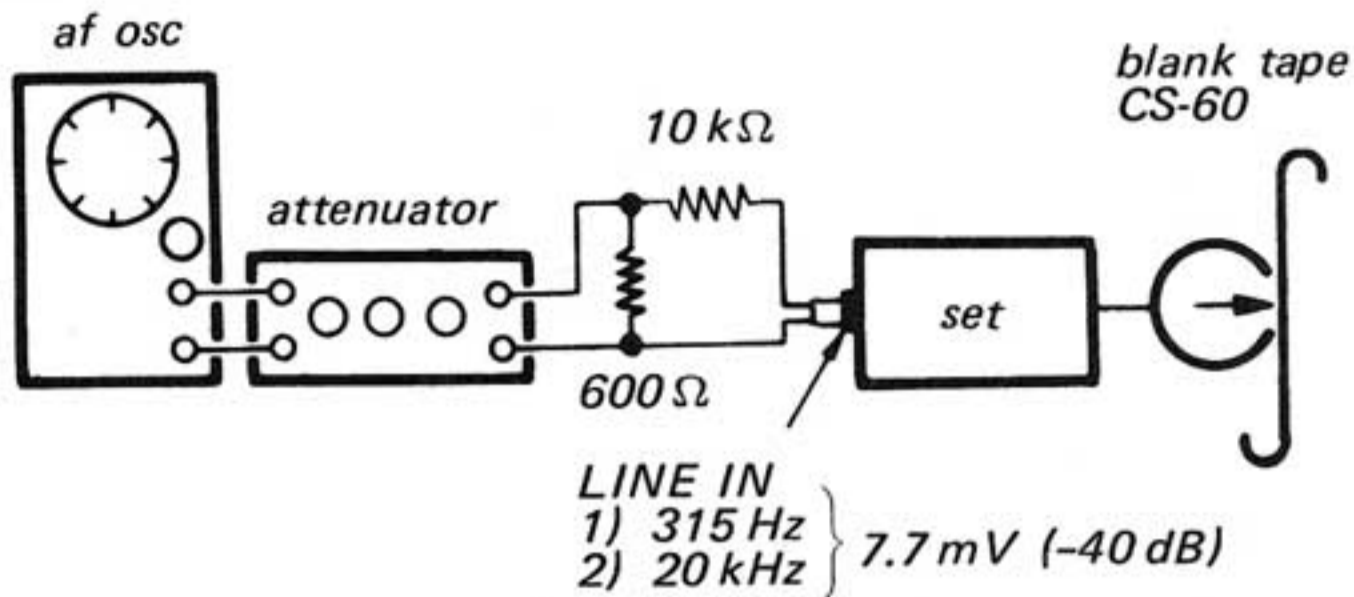

2. Mode: playback

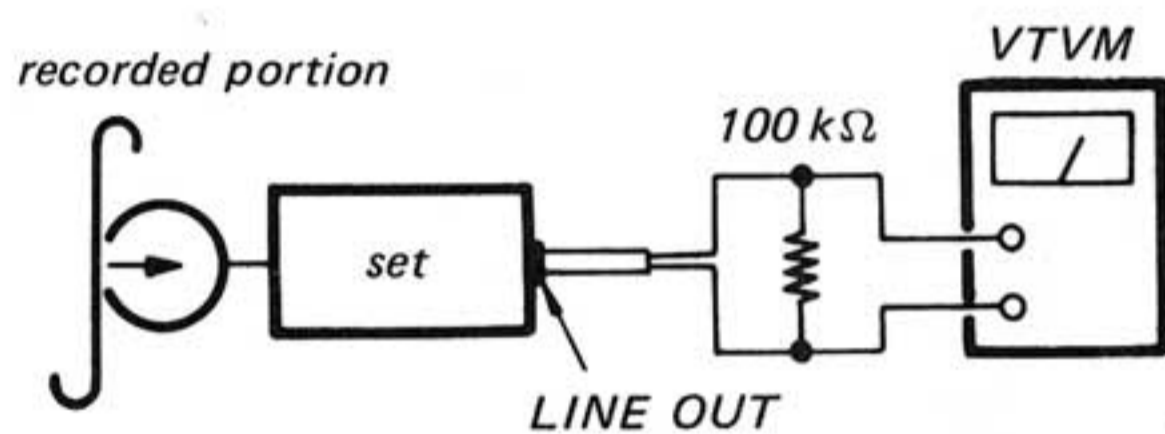

3. Repeating above steps, adjust CT501 (L-CH) and CT502 (R-CH) to make 20 kHz and 315 Hz signal output levels equal.

Adjustment Location:

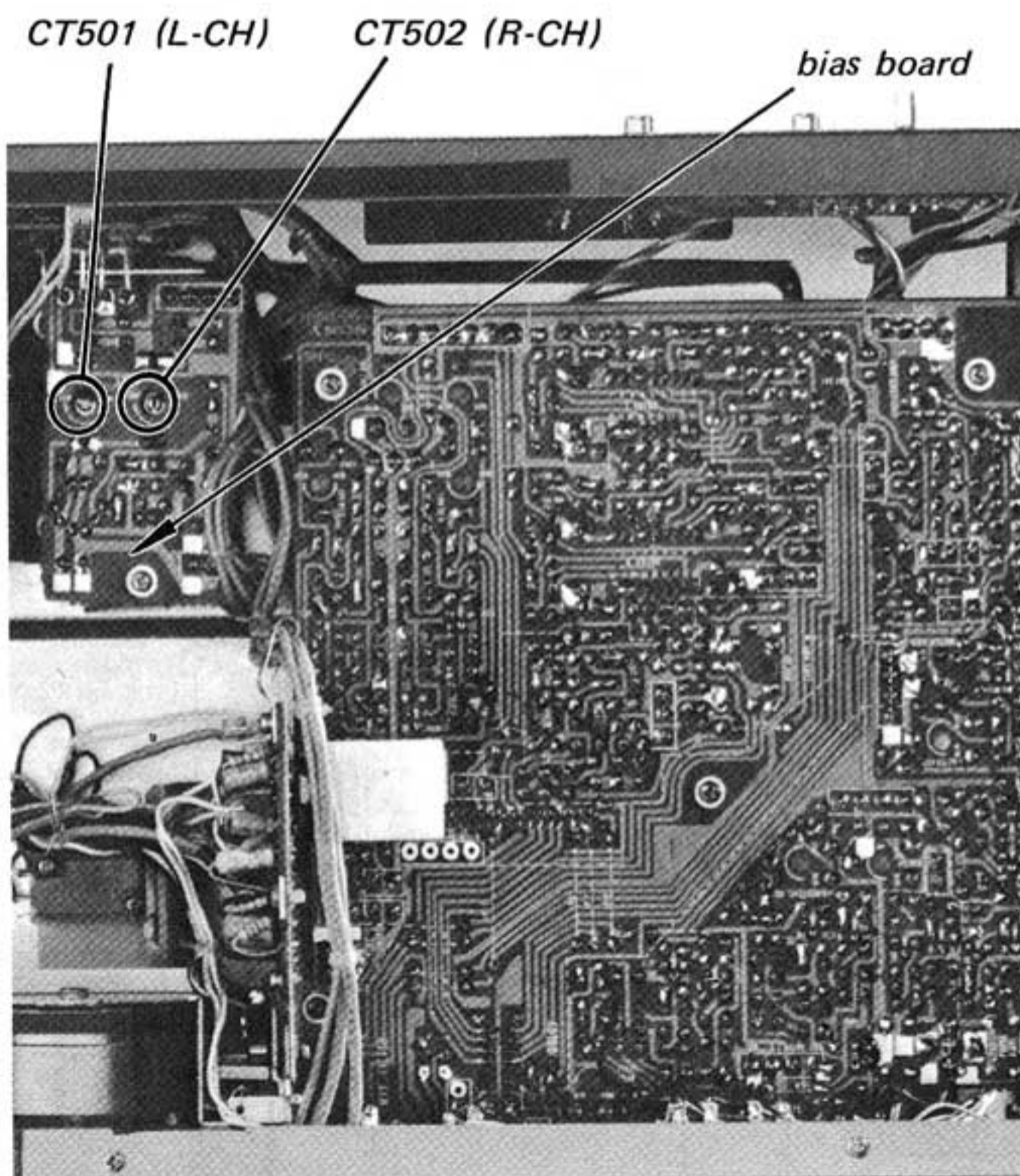

Record Level Adjustment

Setting:

REC LEVEL-LINE control: standard record
(See page 20.)

Procedure:

1. Mode: record

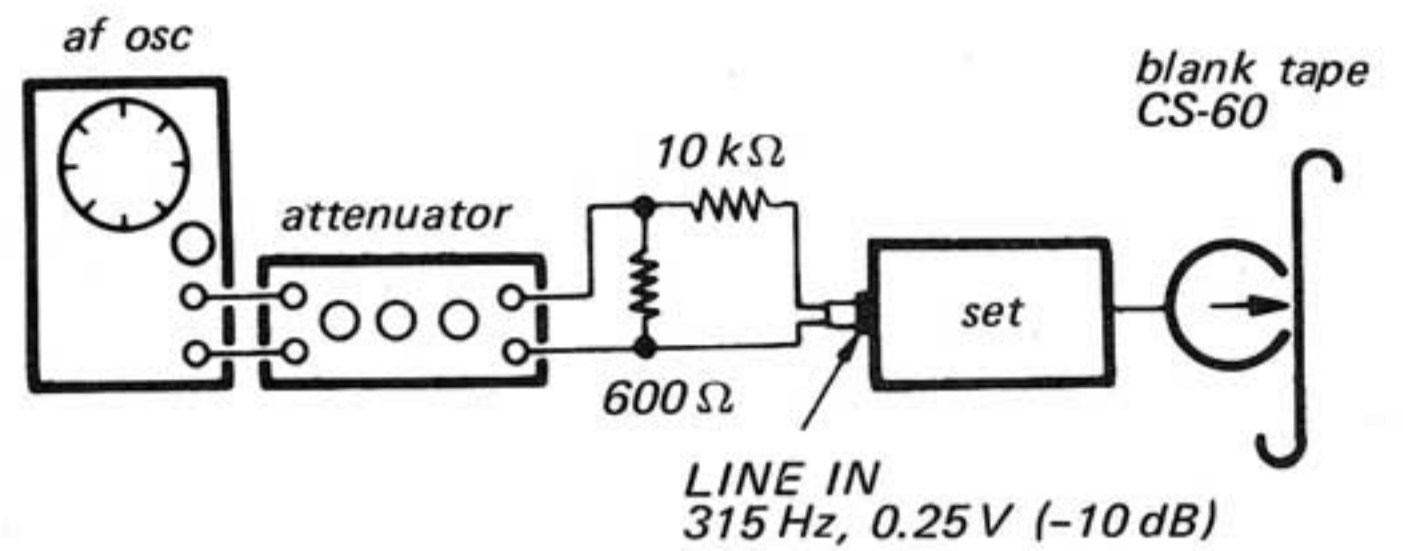

2. Mode: playback

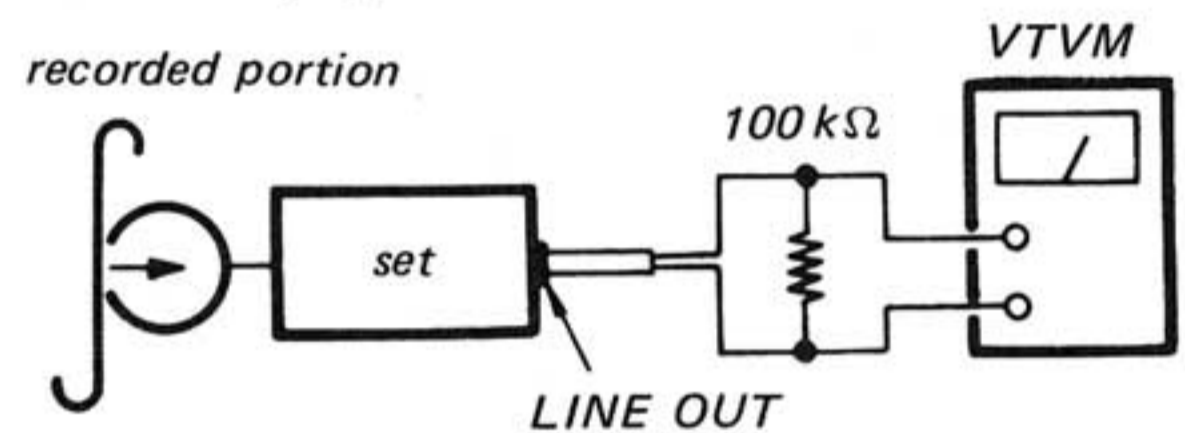

3. Repeating above steps, adjust RV104 (L-CH) and RV204 (R-CH) to obtain 0.69 V–0.85 V (0 dB ± 1 dB) reading on VTVM.

Adjustment Location:

