



AKAI

DVD PLAYER

Model:
A-1211

SERVICE MANUAL

1. CONTENTS

Title	Page
1. CONTENTS	1
2. BLOCK DIAGRAM (CABLE CONNECTIONS)	2
3. POWER SUPPLY	3
4. FUNCTIONAL DESCRIPTIONS	4
4.1 DVD MPEG board	4
4.2 Front Panel	14
4.3 SMPS	15
4.4 DVD Driver	16
5. DESCRIPTION OF THE INTEGRATED CIRCUITS	18
5.1 SWPS TRANSFORMER	18
5.2 SWPS CONTROLLER IC (TEA1523P)	19
5.3 SWPS PROGRAMMABLE SHUNT REGULATOR (FAIRCHILD TL 431)	21
5.4 LINE FILTER(2 x 25mH)	22
6. FAULT TRACING FLOW CHART	23
6.1 POWER SUPPLY	23
6.2 FRONT PANEL	24
6.3 MPEG BOARD	25
7. COMPONENT LIST	26

2. BLOCK DIAGRAM (CABLE CONNECTIONS)

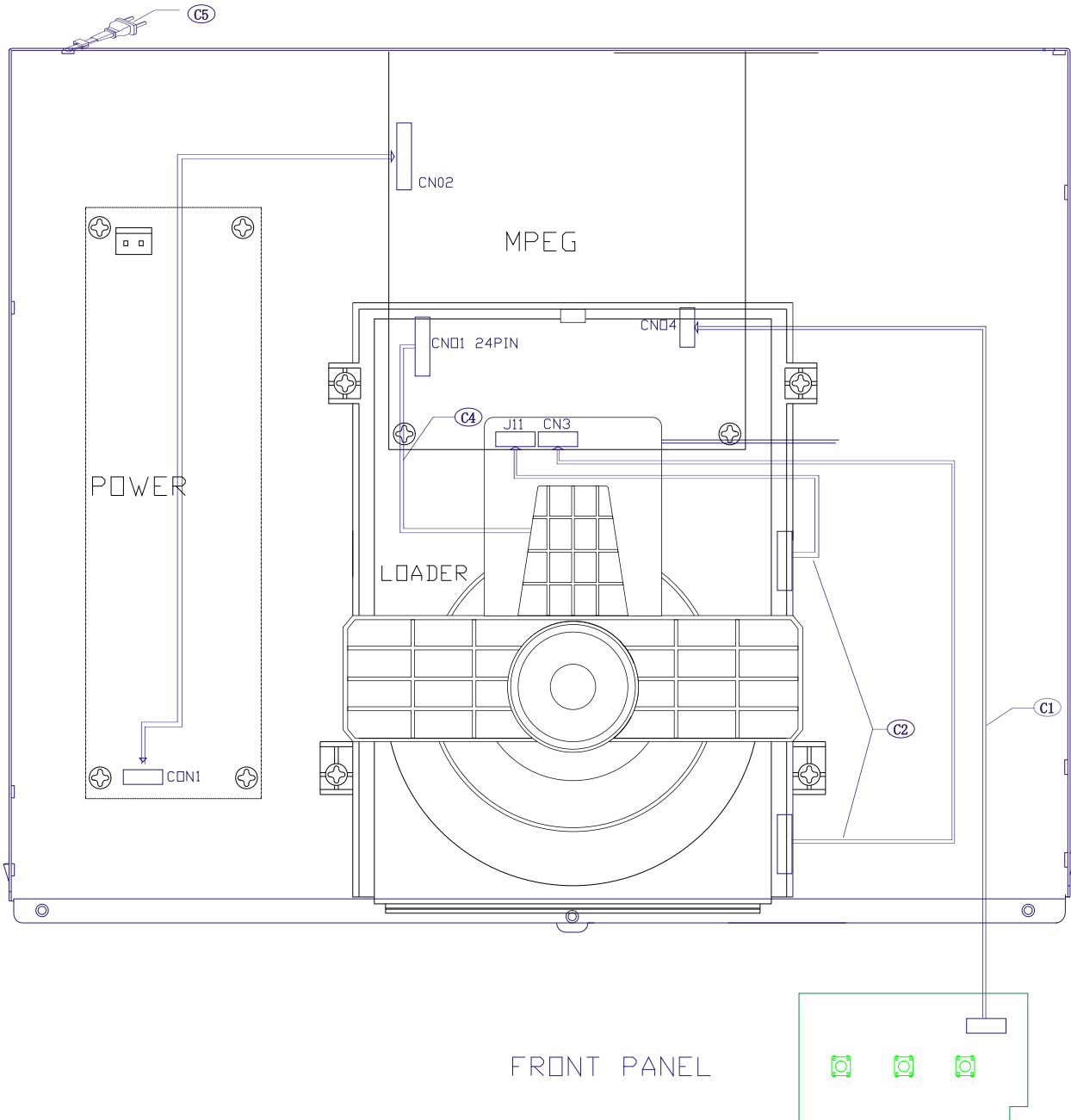

3. POWER SUPPLY

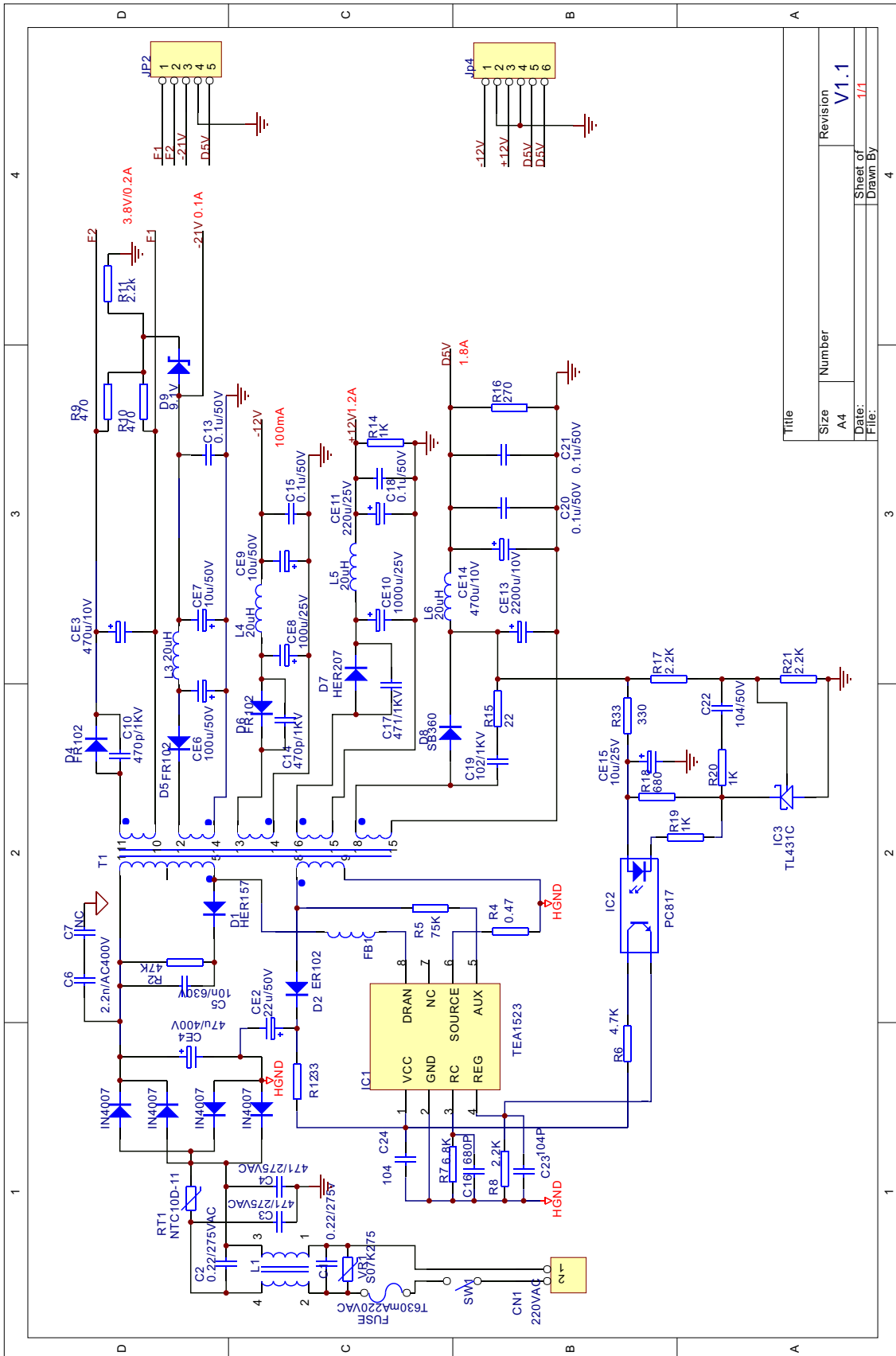

Title	
Size	Number
A4	
Date:	Revision
File:	V1.1
Sheet of	1/1
Drawn By	
	4

4. FUNCTIONAL DESCRIPTIONS

4.1 DVD MPEG board

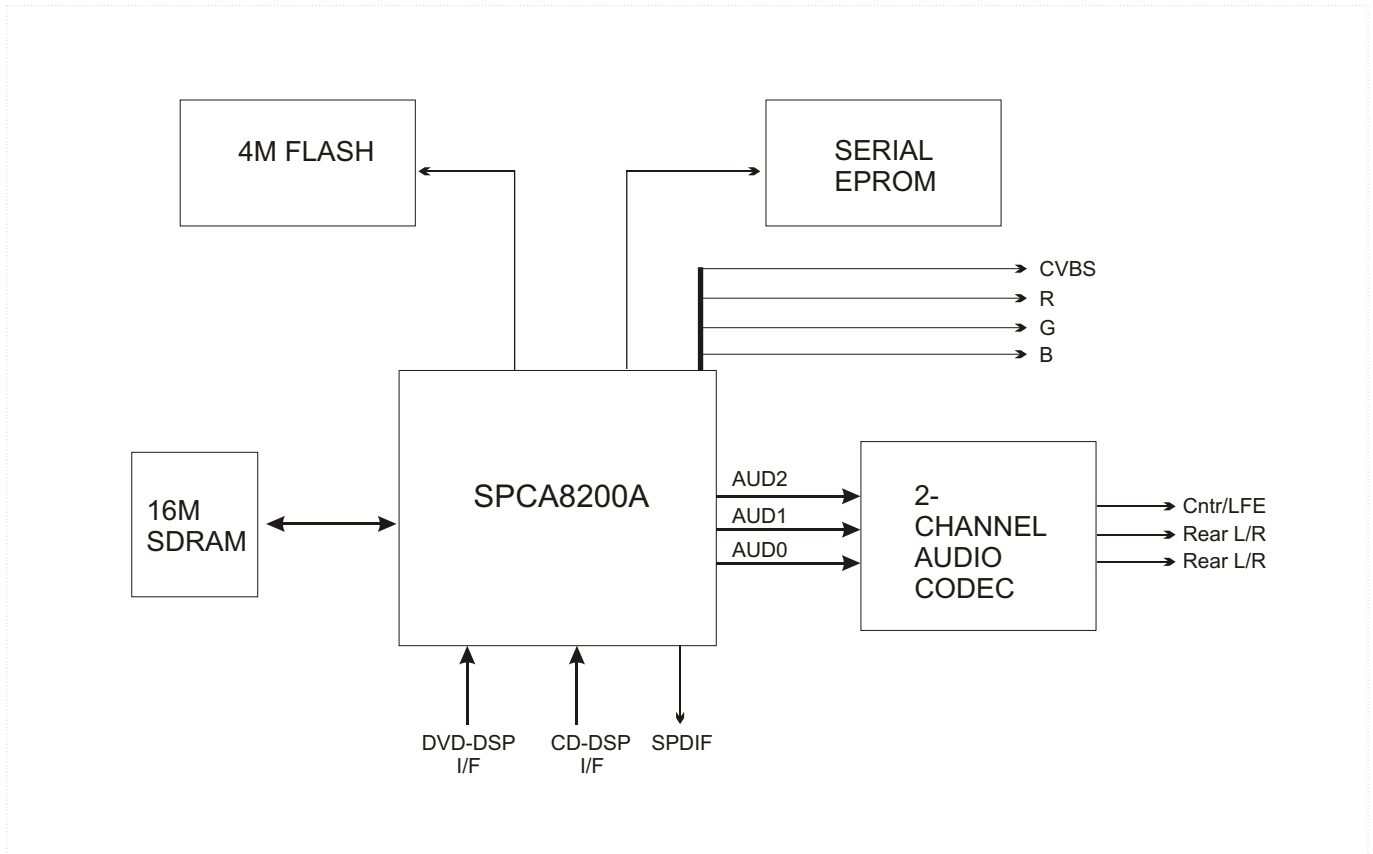

This board implements the back-end circuitry of a DVD player. It is composed of the following subsystems:

- * Microcontroller which does main control to all other sub-blocks of the system including user interface, driver interface, audio/video output.
- * Vaddis A/V Decoder IC decodes the bitstream coming from the DVD front-end drive, and Optionally performs audio and video effects.
- * Audio Codec

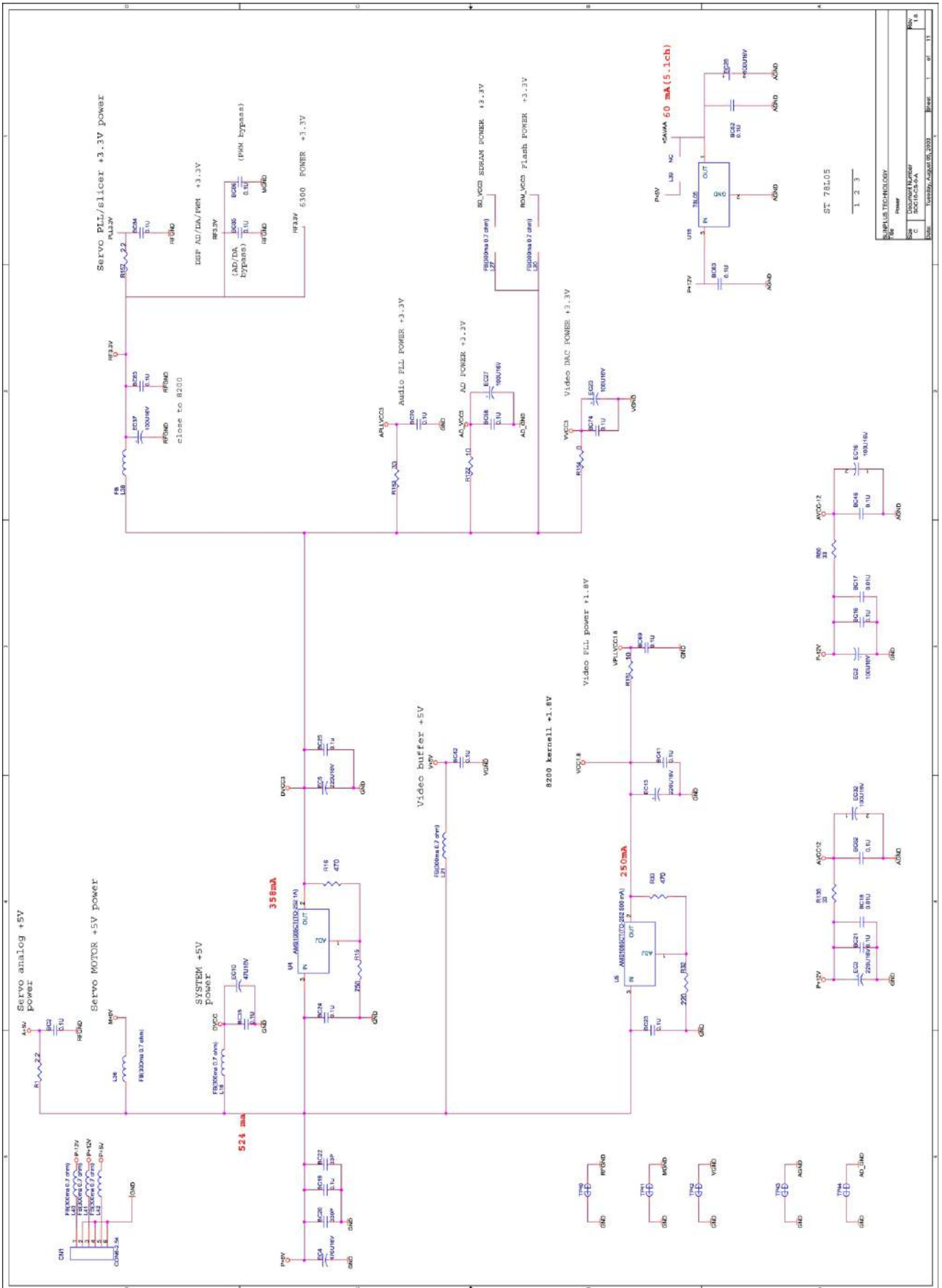

Rev	1	2	3
Date	10/27/99	10/27/99	10/27/99
Doc No	ST 78L05		
Doc Name	ST 78L05		
Doc Rev	1		
Doc Desc	ST 78L05		
Doc Author	ST 78L05		
Doc Checker	ST 78L05		
Doc Engineer	ST 78L05		
Doc Designer	ST 78L05		
Doc Approver	ST 78L05		
Doc Release	ST 78L05		

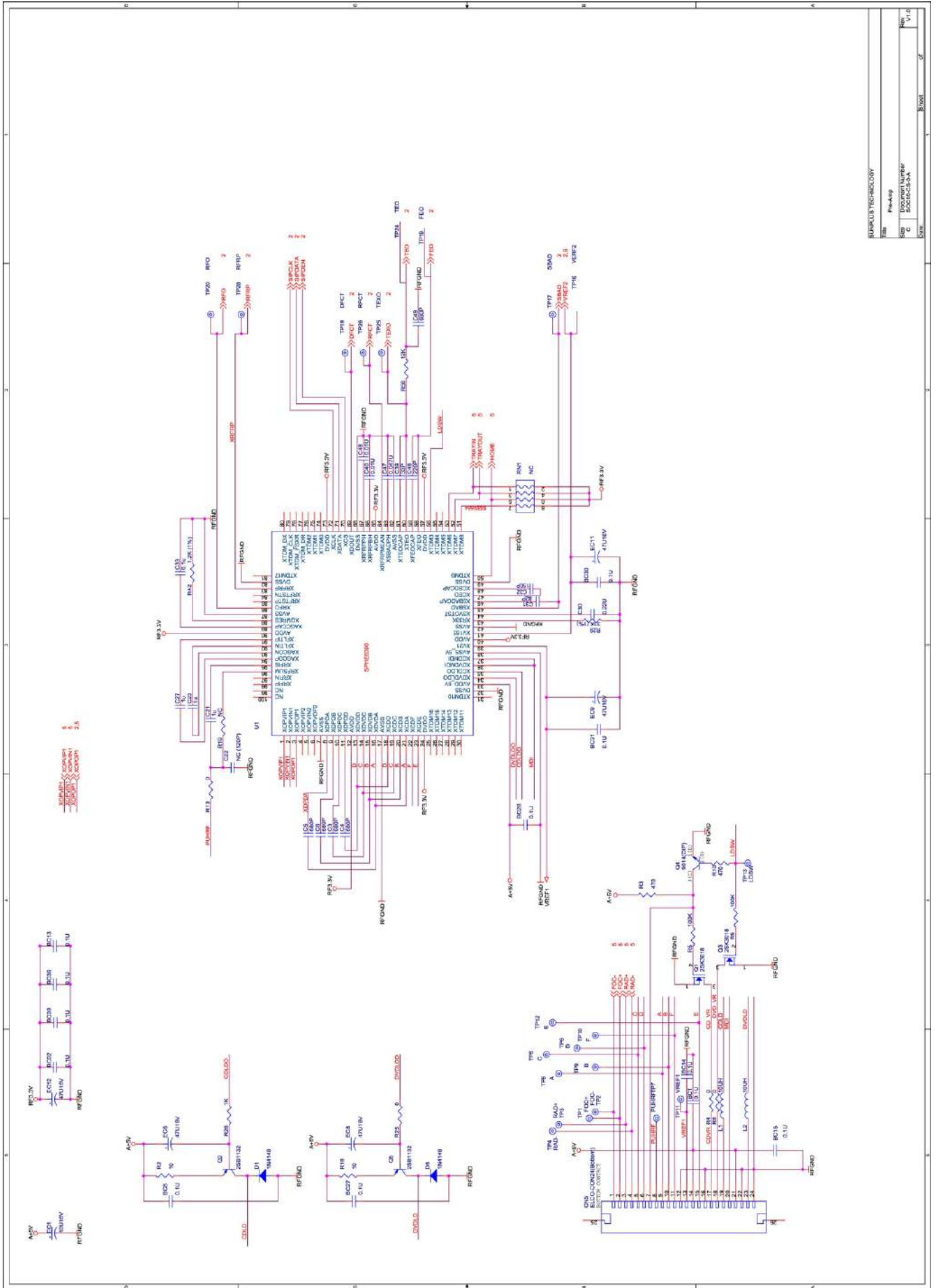

RUPULUS TECHNOLOGY	
Rev:	Rev-4-01
Doc:	Doc-4-01
Part:	5001234567
Ver:	V.1.0
Page:	8

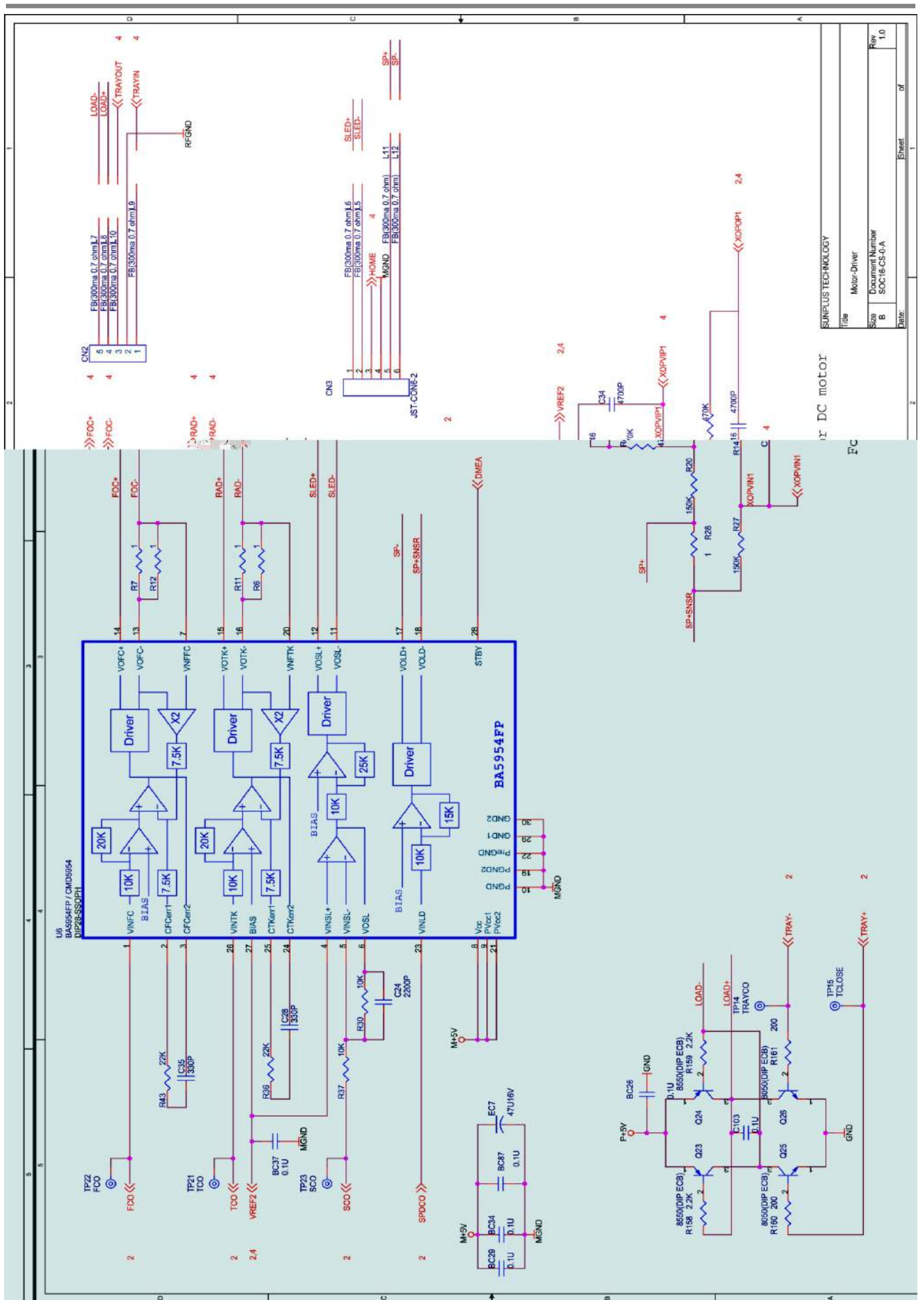

SUNPLUS TECHNOLOGY	
Title	Motor-Driver
Size	Document Number
B	SOC16-CS-01-A
Date:	Rev
	1.0

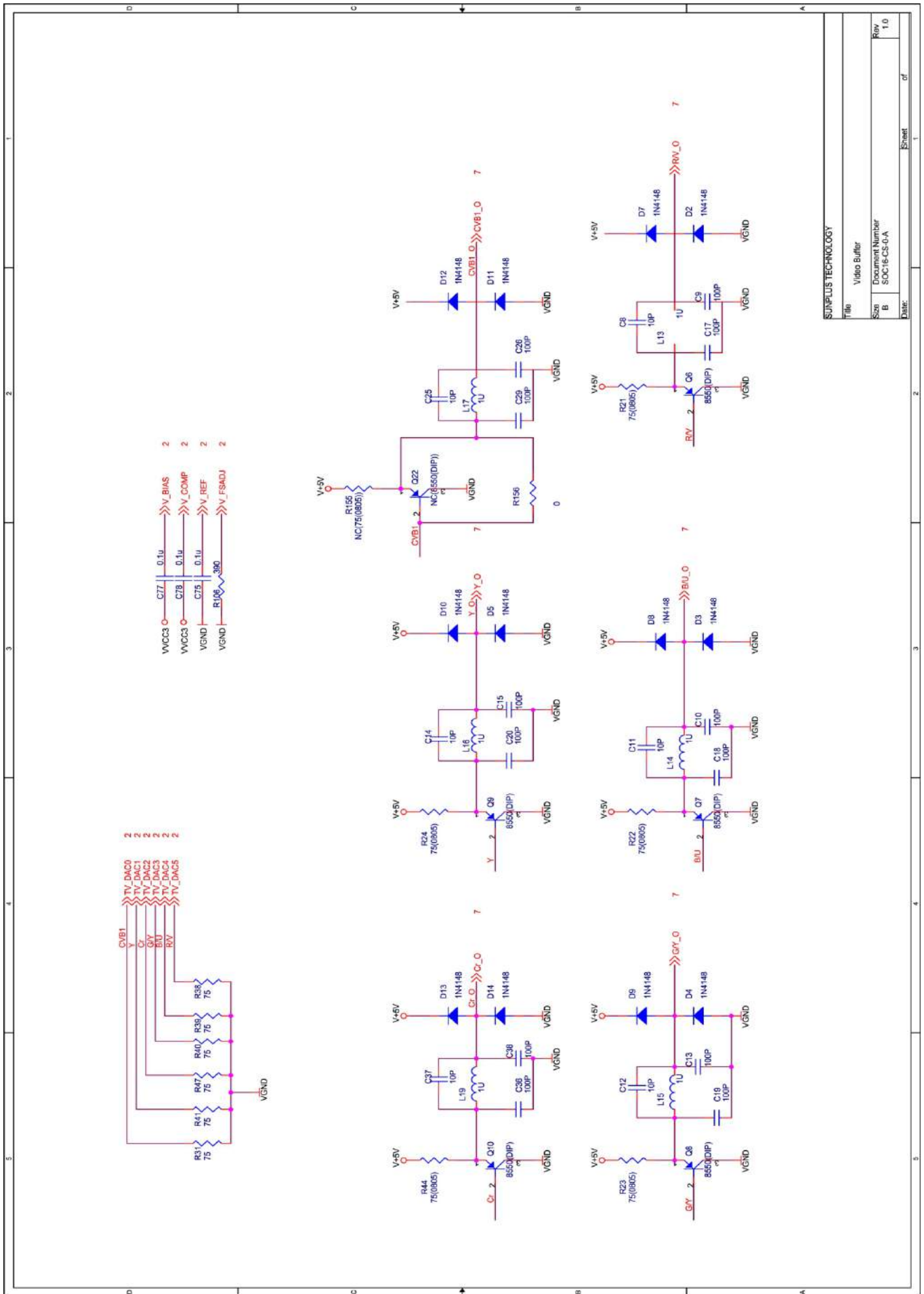

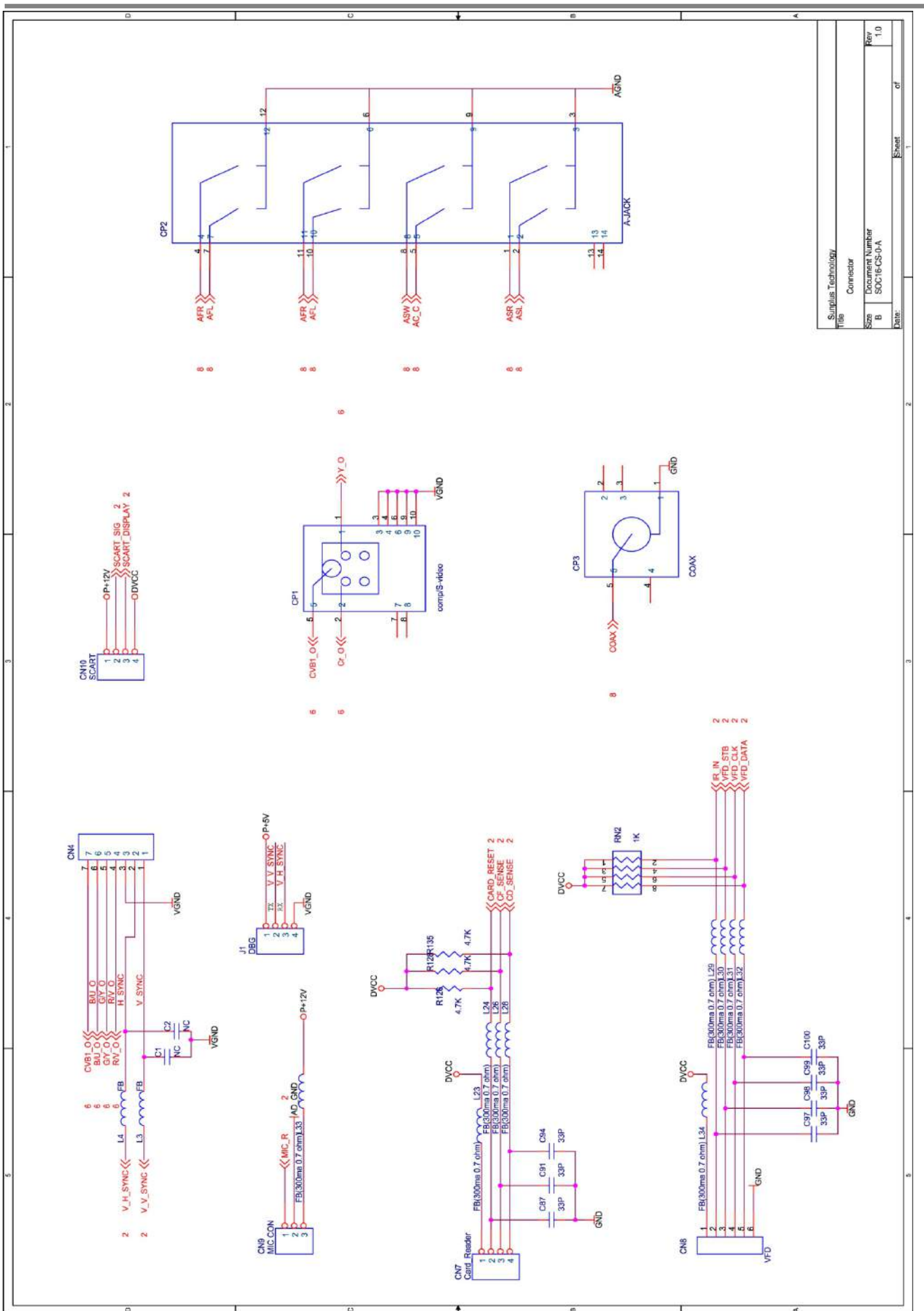

Surplus Technology	
Title	Connector
Size	Document Number
B	SOC16-CS-0-A
Date:	
Sheet	of
1	2
3	4
5	6
7	8
9	10
11	12
13	14
15	16

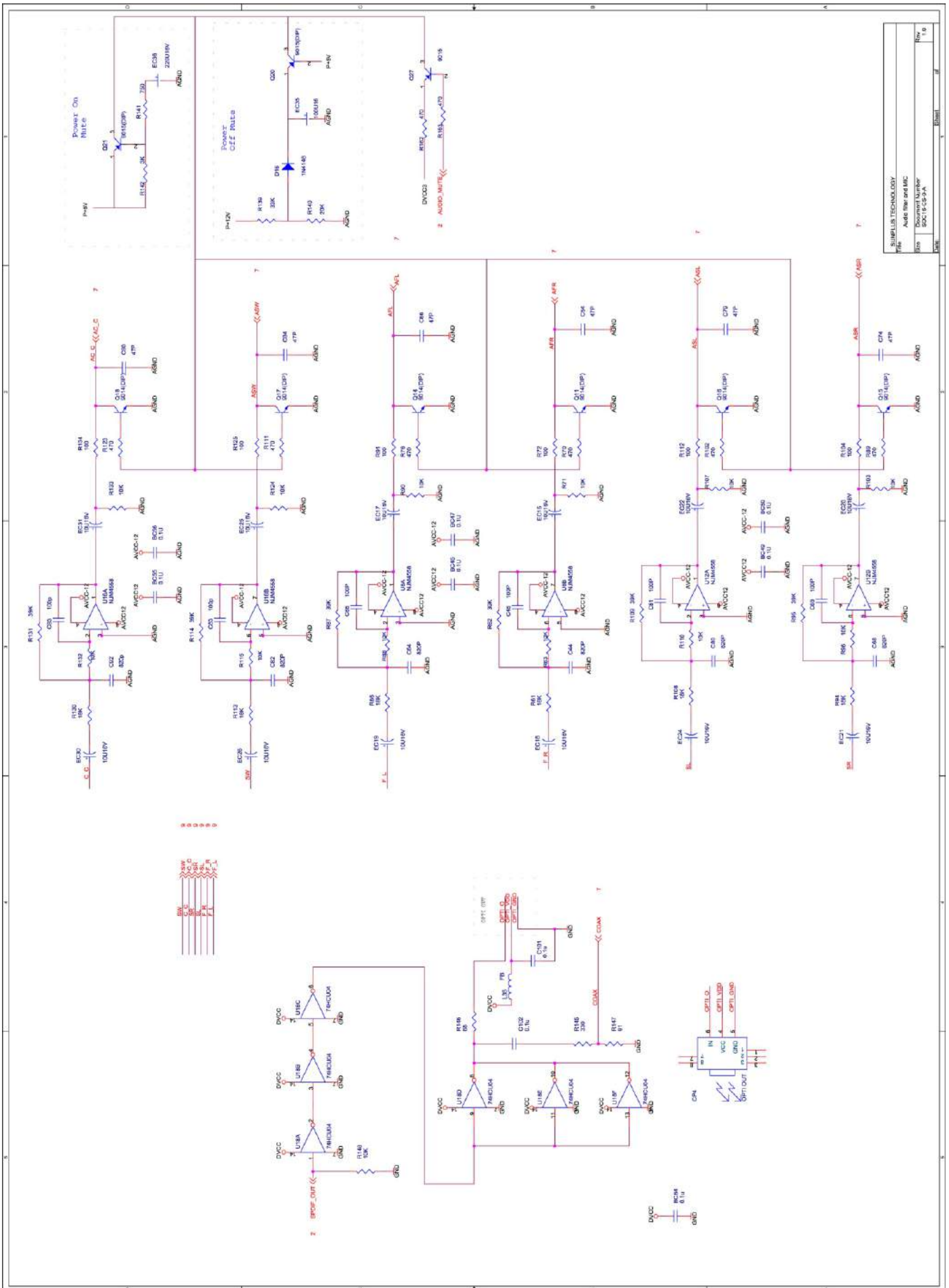

File	SUMILIA TECHNOLOGY
Doc	Audio flow and MC
Doc	Document Number
Doc	SPC15-123-A
Rev	1.0
Ver	

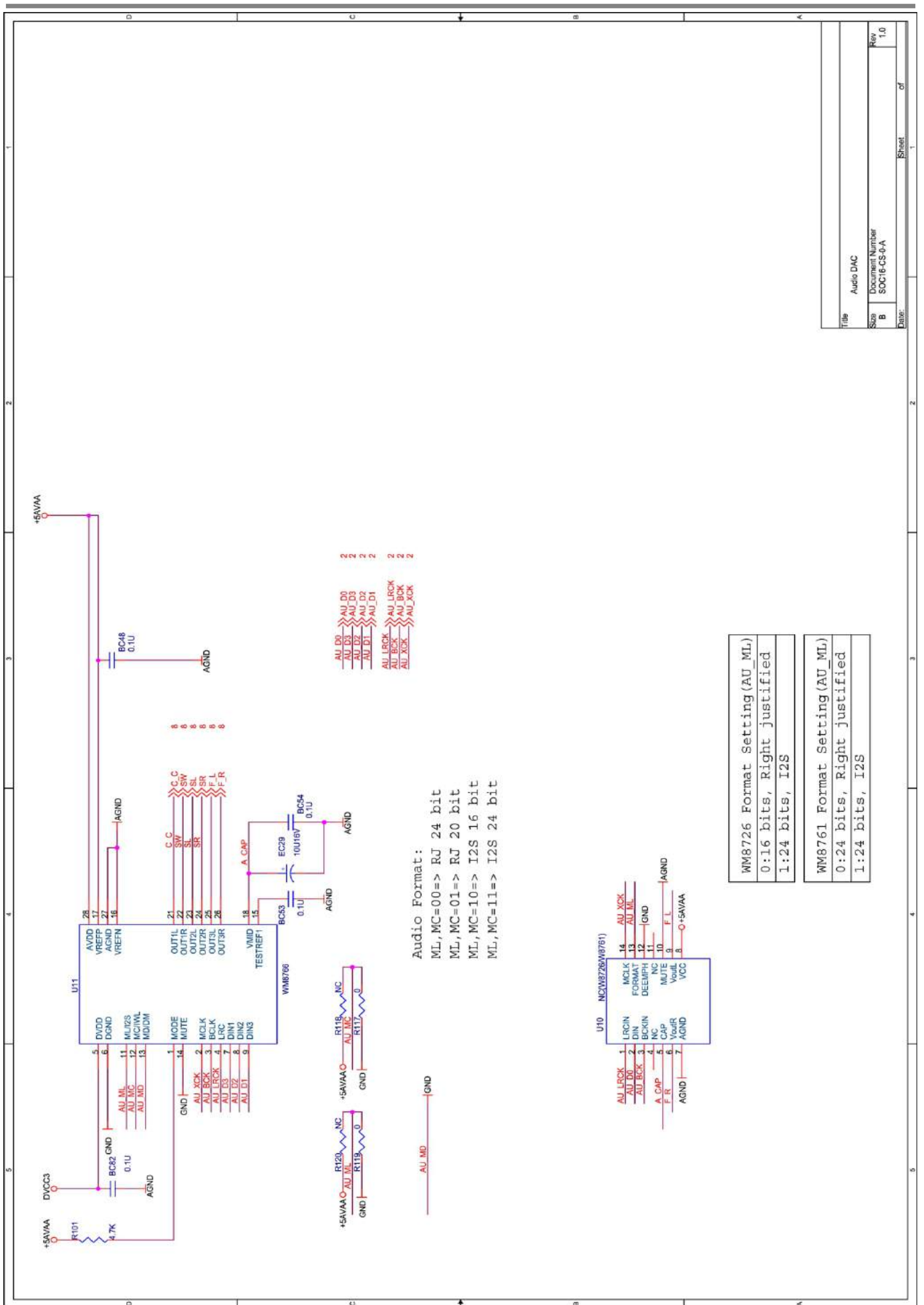

WM8726 Format Setting(AU_ML)	
0:16 bits, Right justified	
1:24 bits, I2S	

WM8761 Format Setting(AU_ML)	
0:24 bits, Right justified	
1:24 bits, I2S	

Title	Audio DAC
Size	Document Number
B	SOC1B-CS-9-A
Rev	1.0
Date:	
Sheet:	of

4.2 Front Panel

The front panel I/O.

A.

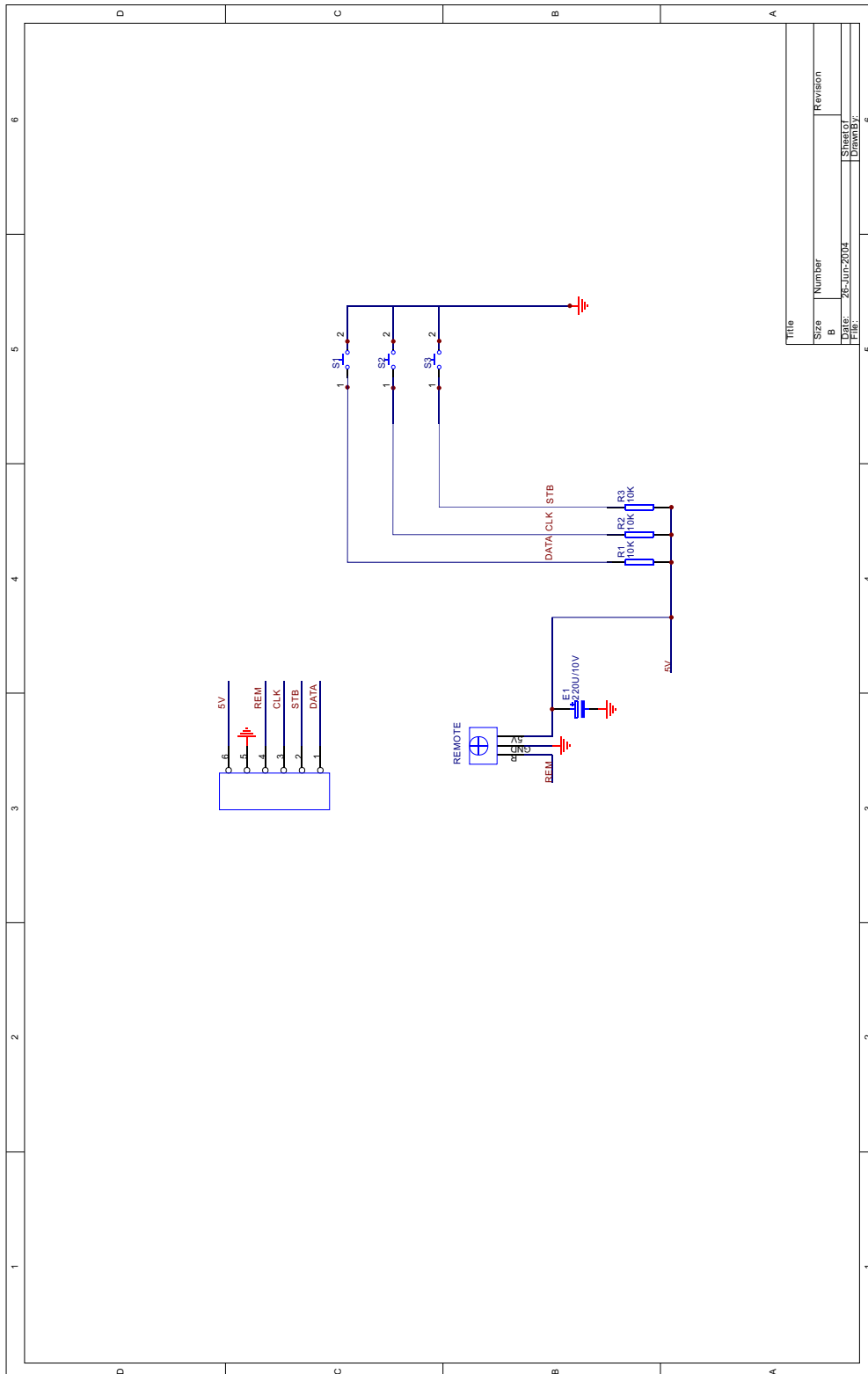

4.2.1 Front Panel Interface

6 Pin, Data Connector Pin Assignments

PIN	NAME	I/O	DESCRIPTION
1	DATA	I	Front Panel Data input
2	STB	O	IR sensor interrupt
3	CLK	O	Front Panel chip select
4	REM	I	Front Panel clock
5	GND	O	Front Panel Data output
6	VCC		

4.3 SMPS

The mains power(220VAC) fed from N1 is filtered through C1, L1, C2 and L2 then rectified by D1, D2, D3 and D4 and generates an output at 300VDC. This 300VDC fed to T1 (pin2, pin4) which connects to TEA1523P(pin2), then TEA1523P will automatically generate a 50KHz square waveform, this 50KHz square waveform controls the ON/OFF between TEA1523P pin2 and the ground. In normal condition, T1 primary (between pin2 and pin4) will create a 50KHz square waveform which is controlled by TEA1523P, this signal then fed to T1 and generates 2 different potential voltages of 12V and 5V between pin17, pin14 and pin16, pin14 respectively. The 12VDC and 5VDC then rectified by D7, D8, D9 and then filtered by L3, L4, L5, C9, C10 and C11. The feedback voltage is controlled by Ic3 TL431 and IC2 PC817. When the output voltage is higher than 5V, the voltage at TL431(2.5V) is compared with R10 and send out a signal to 5L0380R, the output square waveform then will change to adjust the output voltage, this acts as a voltage stabilizer.

4.3.1 Adopt small lens: can adopt SONY310 act lens

4.4 Electric specification

4.4.1 Drive cell: adopt RF-300CA-11450 electricity machine

4.2 Electricity machine work voltage is 3V-5.9V

4.3 General work voltage is 3.3V-5V

4.4 Unilateralism(com or go) move time: <1.5S(add 5V voltage)

4.5 In 5 °C-10°C work current is <120mA

4.5 Testing condition

5.1 Position: level placed

5.2 environment: temperature 22 ± 2 °C

Humidity $50 \pm 5\%$

5.3 Turnover storehouse voltage: $5V \pm 0.5V$

5.4 Standard DVD lens testing frock

5.5 Standard DVD testing dish

5. DESCRIPTION OF THE INTEGRATED CIRCUITS

5.1 SMPS TRANSFORMER

1. GENERAL INFORMATION

Main Voltage Operations:	90Vac - 265 Vac
Main Drop-out Voltage:	Max. 90 Vac
Mains Start-up Voltage:	Max. 90 Vac
Operating Frequency:	60 KHz

2. ELECTRICAL CHARACTERISTICS

2.1 STATIC CHARACTERISTICS

WINDING	PIN. NO	INDUCTANCE	DESCRIPTION
Primary Inductance	2-4	1.5mH 10%	<0.50W

1. Primary Leakage inductance (Pin 2-4) L1.5mH

2.2 WITHSTANDING VOLTAGE

The transformer shall withstand a voltage of 4 Kvms for 1 minute and 1 mA between primary and secondary winding and also 2 Kvms for 1 minute and 1 mA between primary winding with core and secondary winding with core.

2.3 INSULATION RESISTANCE

The insulation resistance shall be more than 500M between primary and secondary windings when the applied voltage 300 Vdc for 1 minute

2.4 ELECTRICAL CHARACTERISTICS

1. Before taking measurement Pp01 will be to give 5.0Vdc on 5.0Vdc line at Minimum setting of controls and a mains voltage 220 Vac.
2. Before taking a measurement, DVD set should be working at least 5 minutes on Normal condition

5.3 SWPS CONTROLLER IC (TEP1523A)

Philips Semiconductors

Product specification

STARplug™

TEA1523 family

FEATURES

- Designed for general purpose supplies up to 50 W
- Integrated power switch:
 - TEA1520: 48 Ω; 650 V
 - TEA1521: 24 Ω; 650 V
 - TEA1522: 12 Ω; 650 V
 - TEA1523: 6.5 Ω; 650 V
 - TEA1524: 3.4 Ω; 650 V.
- Operates from universal AC mains supplies (80 to 276 V)
- Adjustable frequency for flexible design
- RC oscillator for load insensitive regulation loop constant
- Valley switching for minimum switch-on loss (not implemented in TEA152xAJM versions)
- Frequency reduction at low power output makes low standby power possible (<100 mW)
- Adjustable overcurrent protection
- Under voltage protection
- Temperature protection
- Short circuit winding protection
- Simple application with both primary and secondary (opto) feedback
- Available in 8-pin DIP, 14-pin SO and 9-pin DBS packages.

GENERAL DESCRIPTION

The TEA152x family is a Switched Mode Power Supply (SMPS) controller IC that operates directly from the rectified universal mains. It is implemented in the high voltage EZ-HV SOI process, combined with a low voltage BICMOS process. The device includes a high voltage power switch and a circuit for start-up directly from the rectified mains voltage.

A dedicated circuit for valley switching is built in (not implemented in TEA152xAJM versions), which makes a very efficient slim-line electronic powerplug concept possible.

In its most basic version of application, the TEA152x family acts as a voltage source. Here, no additional secondary electronics are required. A combined voltage and current source can be realized with minimum costs for external components. Implementation of the TEA152x family renders an efficient and low cost power supply system.

Table 1 Available type numbers

R _{DS(on)}	DIP8	SO14	DBS9P
48 Ω	TEA1520P	TEA1520T	–
24 Ω	TEA1521P	TEA1521T	–
12 Ω	TEA1522P	TEA1522T	TEA1522AJM
6.5 Ω	TEA1523P	TEA1523T	TEA1523AJM
3.4 Ω	TEA1524P	–	TEA1524AJM

APPLICATIONS

Typical application areas for the STARplug™ are:

- Chargers
- Adapters
- STB (Set Top Box)
- DVD
- CD(R)
- TV/monitor standby supplies
- PC peripherals
- Microcontroller supplies in home applications and small portable equipment, etc.

5.3 SWPS CONTROLLER IC (TEP1523A)

Philips Semiconductors

Product specification

STARplug™

TEA1523 family

BLOCK DIAGRAM

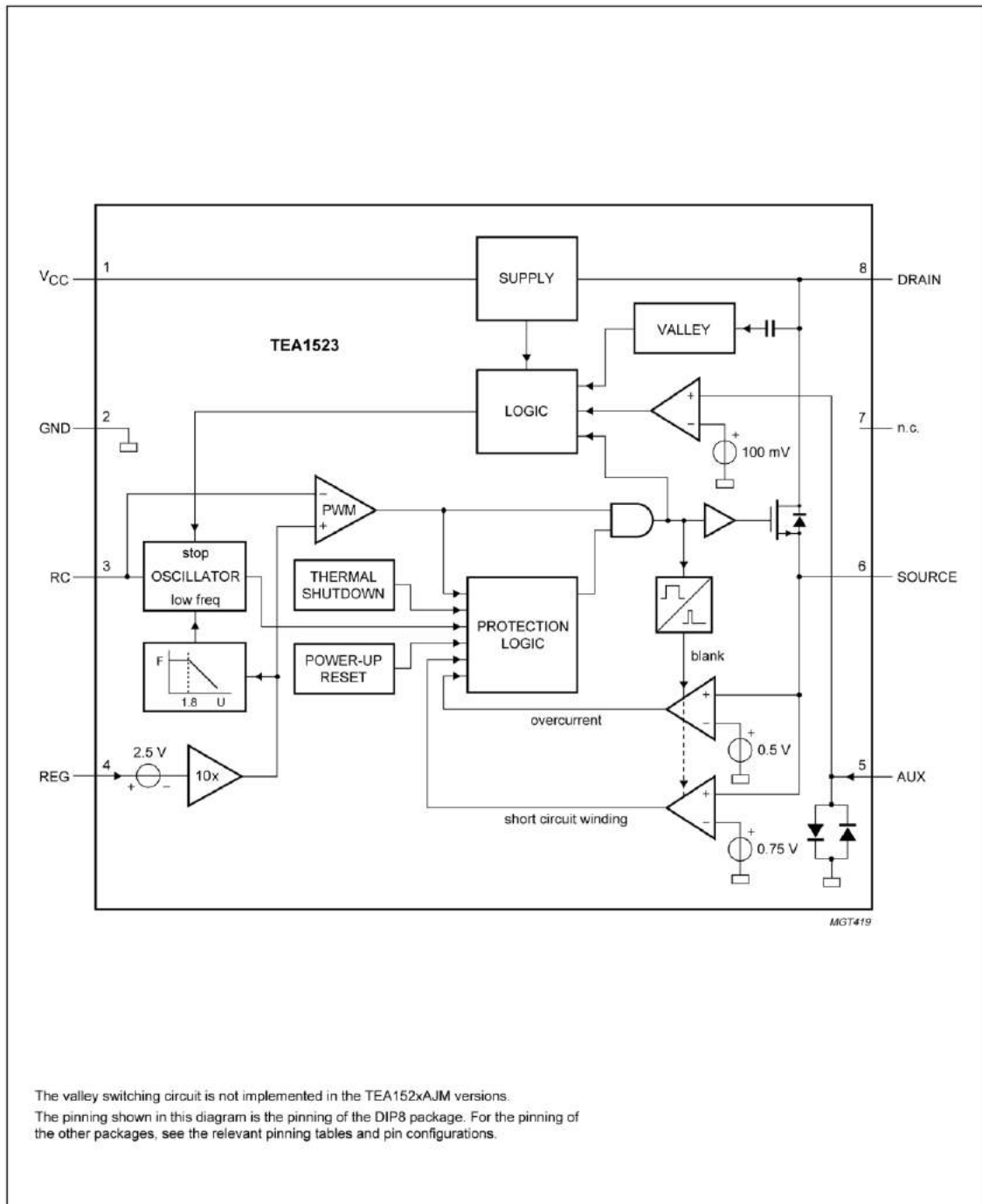

5.4 SMPS PROGRAMMABLE SHUNT REGULATOR (FAIRCHILD TL 431)

Features

- * Programmable output voltage to 36volts
- * Low dynamic output impedance 0.20 typical
- * Sink current capability of 1.0 to 100mA
- * Equivalent full-range temperature coefficient of 50 ppm typical
- * Temperature compensated for operation over full rated operating temperature range
- * Low output noise voltage
- * Fast turn-on response

Description

The TL 431/TL 431A are three-terminal adjustable regulator series with a guaranteed thermal stability over applicable temperature ranges. The output voltage may be set to any value between VREF (approximately 2.5 volts) and 36 volts with two external resistors. These devices have a typical dynamic output impedance of 2.0Ω. Active output circuitry provides a very sharp turn-on characteristic making these devices excellent replacement for zener diodes in many applications.

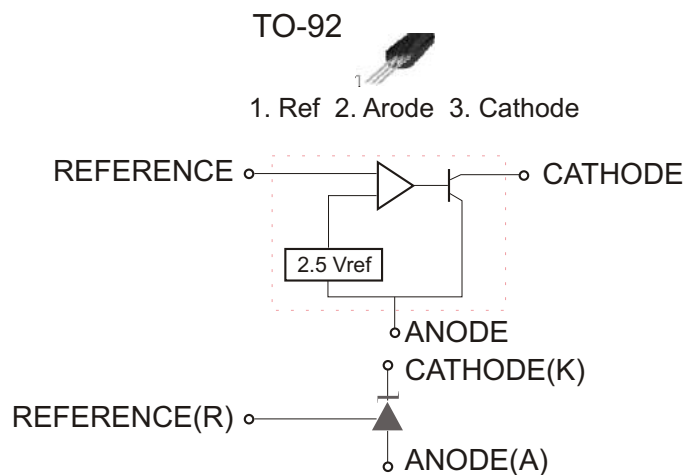

Absolute maximum ratings

Parameter	Symbol	Value	Unit
Cathode voltage	VKA	37	V
Cathode current Range (Continuous)	IKA	-100 ~ +150	MA
Reference Input Current Range	IREF	0.05 ~ +10	MA
Power dissipation D,Z Suffix Package N Suffix Package	PD	770 1000	MW MW
Operating Temperature Range	TOPR	-25 ~ +85	
Storage Temperature Range	TSTG	-65 ~ +150	

Recommended Operating conditions

Parameter	Symbol	Value	Value	Value	Unit
Cathode voltage	VKA	VREF	-	36	V
Cathode Current	IKA	1.0	-	100	MA

5.5 LINE FILTER (2 X 25mH)

ELECTRICAL DATA

Inductance: L1-2=L3-4=30mH - 15% - +20%

Resistance: R 1-2 = R 3-4 = 1.0 ohm (max)

Rated current: I_{rms} = 0.50 A
(F= 1 KHz V= 1 Vms)

LEAKAGE INDUCTANCE

L 1-2 = L 3-4 100+/- 20%uH NOTES

CIRCUIT DIAGRAM

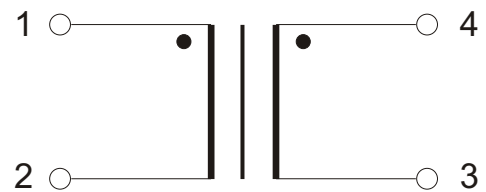

6. FAULT TRACING FLOW CHART

6.1 POWER SUPPLY

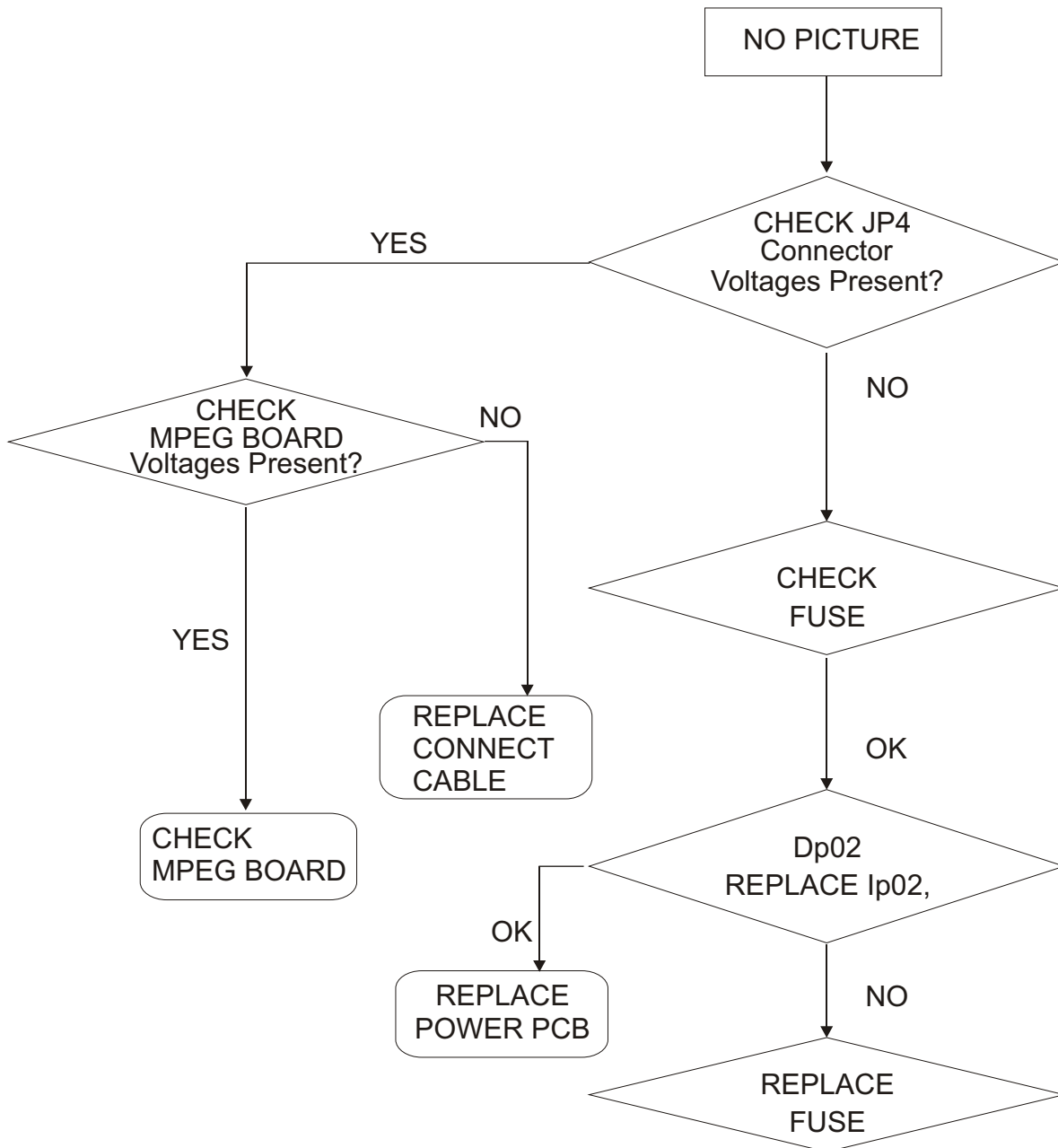

6.2 FRONT PANEL

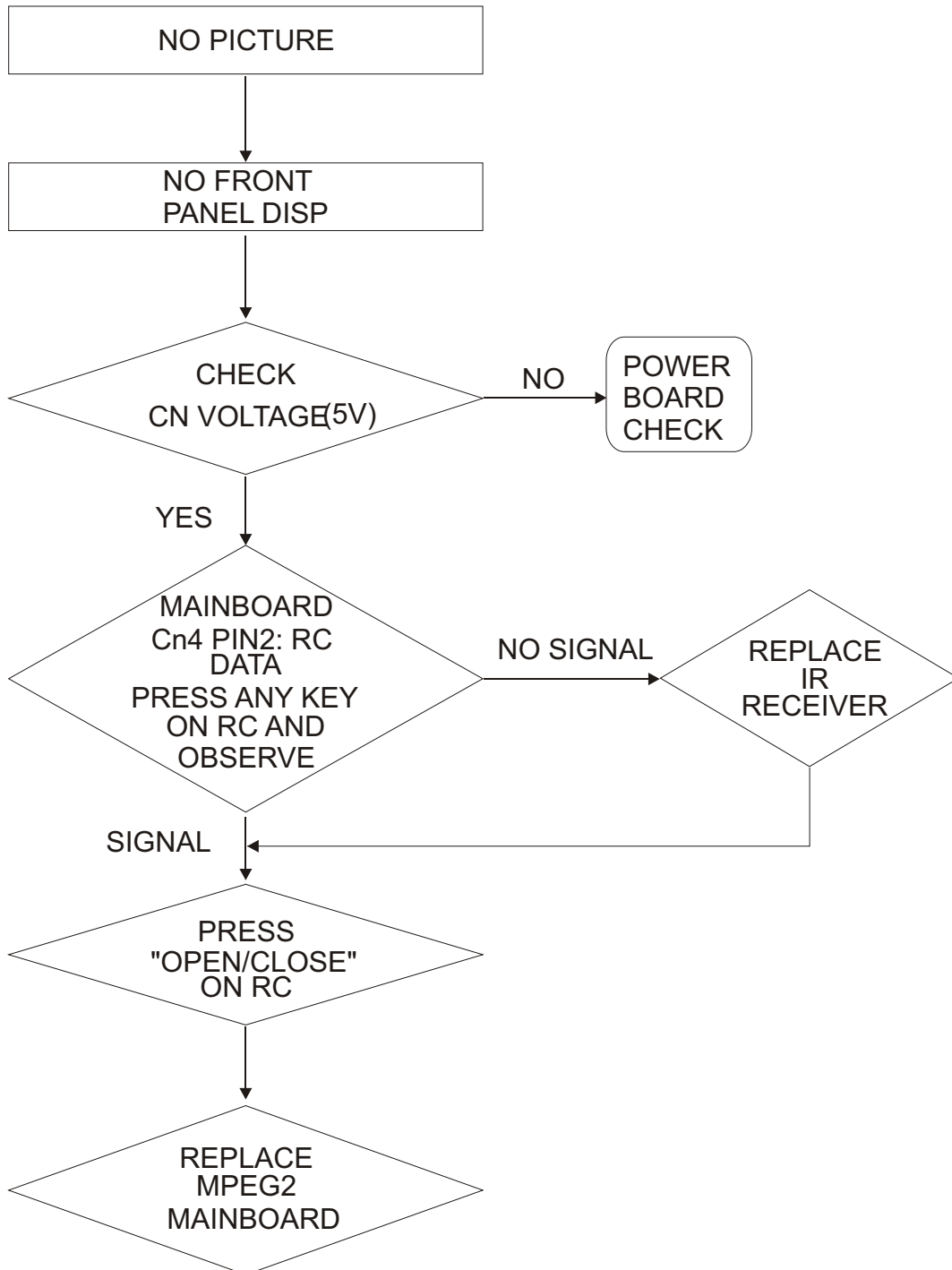

6.3 MPEG BOARD

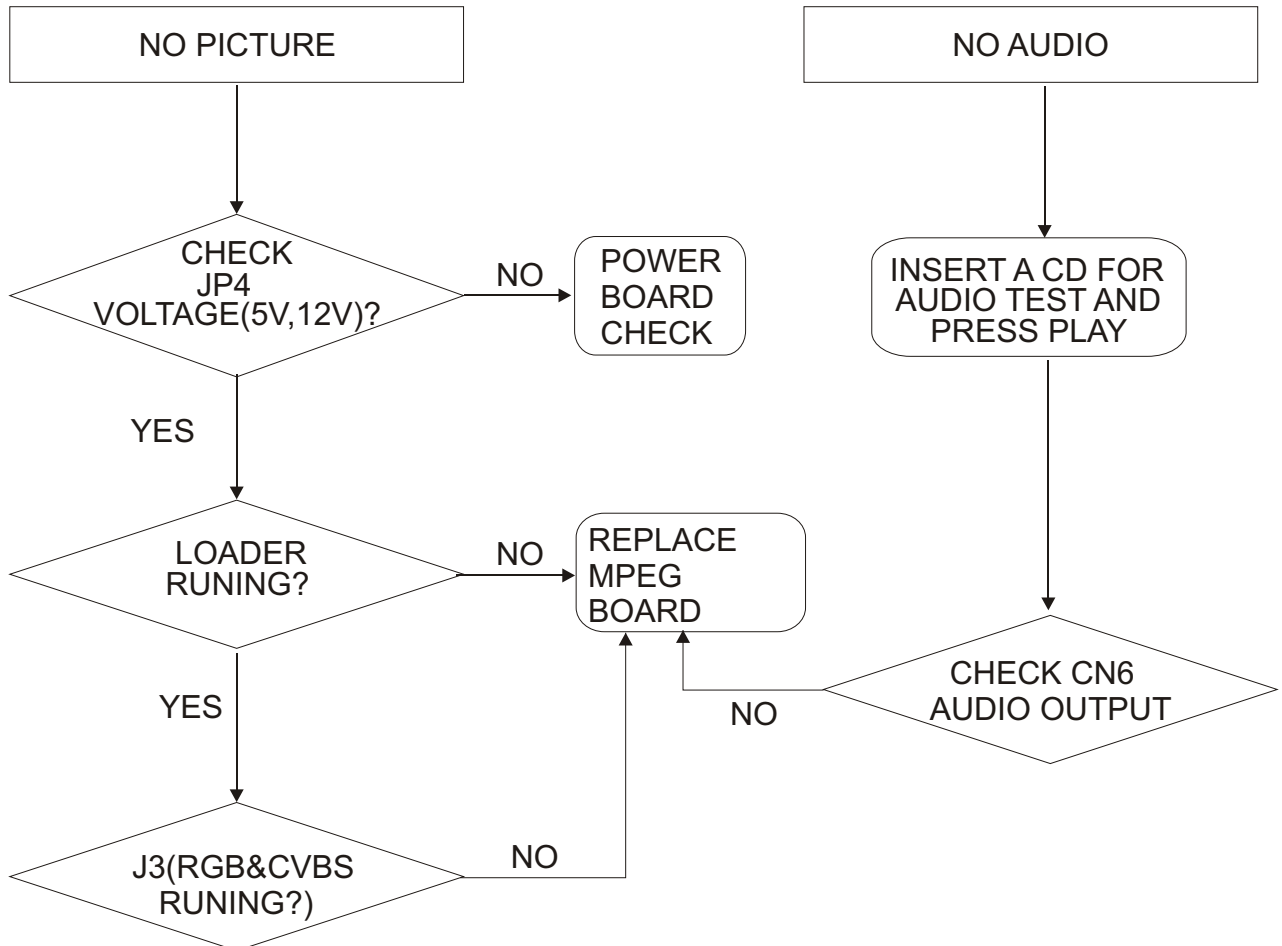

7. COMPONENT LIST

CABLE

POS NO	TELRACTCODE	DESCRIPTION
		6Pin,2.0mmPitch to 6Pin,2.0mmPitch VH,180mm,UL2468 26AWG
		5Pin,2.0mmPitch to 5Pin,2.0mmPitch PH,150mm,UL2468 26AWG
		6Pin,2.54mmPitch to 6Pin,2.54mmPitch VH,250mm,UL2468 26AWG
		5Pin,2.54mmPitch,VH to MPEG Power Socket,280mm,UL1007 20AWG
		Power Cable,180m,VDE
		AV Cable,1.5m

SWPS

POS NO	TELRACTCODE	DESCRIPTION
C1		104K M 275V-X2 3355 MKP
C2		104K M 275V-X2 3355 MKP
C3		Ceramic Cap.,471K M 275V-X1,Y1 335
C4		Ceramic Cap.,471K M 275V-X1,Y1 335
C5		Ceramic Cap.,1KV 103M 10%
C6		Ceramic Cap.,1KV-101,K
C7		Ceramic Cap.,50V 473,10%
C8		Ceramic Cap.,63V 104,10%
C9		Ceramic Cap.,63v 104,10%
CA1		Ceramic Cap.,222 M 400V-X1,Y1 335
CE4		Elec. Cap.,400V-47UF,M,18X27mm
CE2		Elec. Cap.,50V-22UF,M,5X11.5mm
CE6		Elec. Cap.,35V-220UF,M,8X11.5mm
CE11		Elec. Cap.,35V-220UF,M,8X11.5mm
CE10		Elec. Cap.,25V-1000UF,M,10X20mm
CE13		Elec. Cap.,10V-2200UF,M,10X20mm
CE14		Elec. Cap.,16V-220UF,M,6.3X11mm
CE15		Elec. Cap.,10V-100UF,M,5X11mm
BR1		Rectifier Diode,1N4007,DO-41
BR2		Rectifier Diode,1N4007,DO-41
BR3		Rectifier Diode,1N4007,DO-41
BR4		Rectifier Diode,1N4007,DO-41
D1		Rectifier Diode,HER105,DO-41
D2		Switch Fr102 ,DO-41
D3		Rectifier Diode,FR102,DO-27
D4		Rectifier Diode,FR104,DO-27
D5		Rectifier Diode,FR104,DO-27
D6		Rectifier Diode,FR157,DO-41
D7		Rectifier Diode,SR360,DO-41
D8		Zener Diode,9.1V
FHB		FB, 3.5mm*4.7mm*0.8mm
FUSE		Fuse,T1AL250V,5*20mm,Glass
IC-1		IC,TEA1523P DIP8
IC-2		IC,PC817B
IC-3		IC,TL431C,TO-92
J-1		Jumper,Diameter=0.6mm,L=10mm
J-2		Jumper,Diameter=0.6mm,L=5mm
J-3		Jumper,Diameter=0.6mm,L=7.5mm

POS NO	TELRA CODE	DESCRIPTION
L-1		Filter,ET20
L-2		Filter,SG01183
L-3		Radial Choke Inductor,15uH 10%
L-4		Radial Choke Inductor,15uH 10%
L-5		Radial Choke Inductor,15uH 10%
Cn1		Conn.,2Pin,VH,3.96mm,S
Cn2		Conn.,2Pin,VH,3.96mm,S
CON1		Conn.,5Pin,2.54mm,S
CON2		Conn.,6Pin,2.54mm,S
N4		Conn.,4Pin,2.54mm,S
PCB		PCB,POW389L
R1		Carbon Film Res.,2W-56K,J
R2		Carbon Film Res.,1/4W-22E,J
R3		Carbon Film Res.,1/4W-330E,J
R4		Carbon Film Res.,1/4W-1K,J
R5		Carbon Film Res.,1/4W-1M,J
R6		Carbon Film Res.,1/4W-10K,J
R7		Carbon Film Res.,1/4W-10K,J
R8		Carbon Film Res.,1/4W-10K,J
R9		Carbon Film Res.,1/4W-1E,J
R10		Carbon Film Res.,1/4W-680E,J
TR-1		NTC 10D-11
T1		Transformer,KB-464-3089

FRONTPANEL

POS NO	TELRA CODE	DESCRIPTION
CD1		Elec. Cap.,220uF-10V,5*7mm,CD11,M
RD1		Carbon Film Res.,1/8W,10K,J
RD2		Carbon Film Res.,1/8W,10K,J
RD3		Carbon Film Res.,1/8W,10K,J
REMO1		Remote Receiver,GPIUM271RK
SW1		Tact Switch,6*6*5mm
SW2		Tact Switch,6*6*5mm
SW3		Tact Switch,6*6*5mm