

SERVICE MANUAL

PARTS LIST

MODEL AA-1020DB



**THIS MANUAL MUST BE USED AS A SET TOGETHER WITH
SEPARATELY PUBLISHED AA-1020/L SERVICE MANUAL**

AKAI STEREO RECEIVER

MODEL AA-1020DB

**THIS MANUAL MUST BE USED AS A SET TOGETHER WITH
SEPARATELY PUBLISHED AA-1020/L SERVICE MANUAL**

SECTION 1	SERVICE MANUAL	1
SECTION 2	PARTS LIST	15

2. COMPOSITION OF VARIOUS P.C BOARDS

1) MULTI FUNCTION P.C BOARD AA-5395A

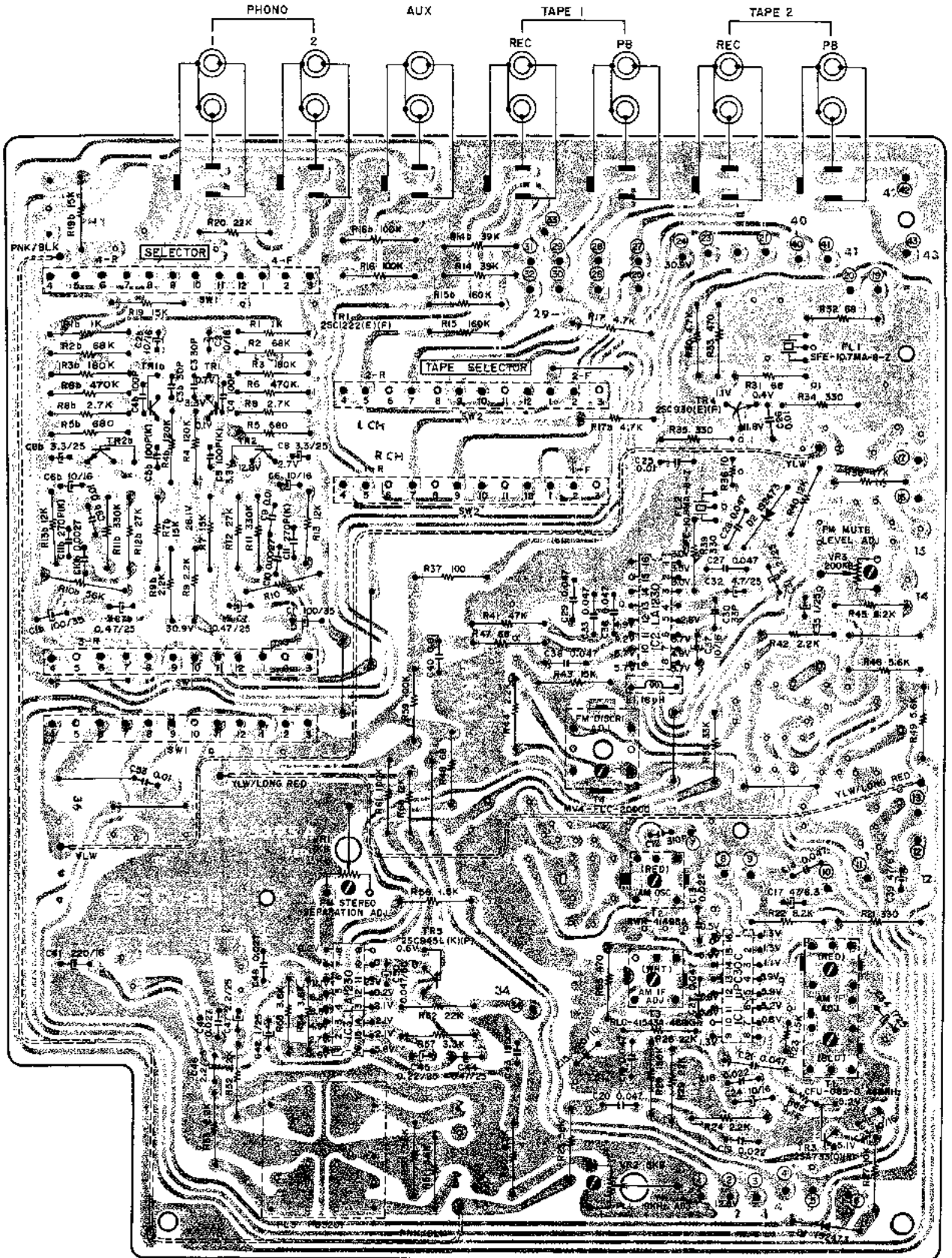

2) MAIN AMP P.C BOARD AA-5275

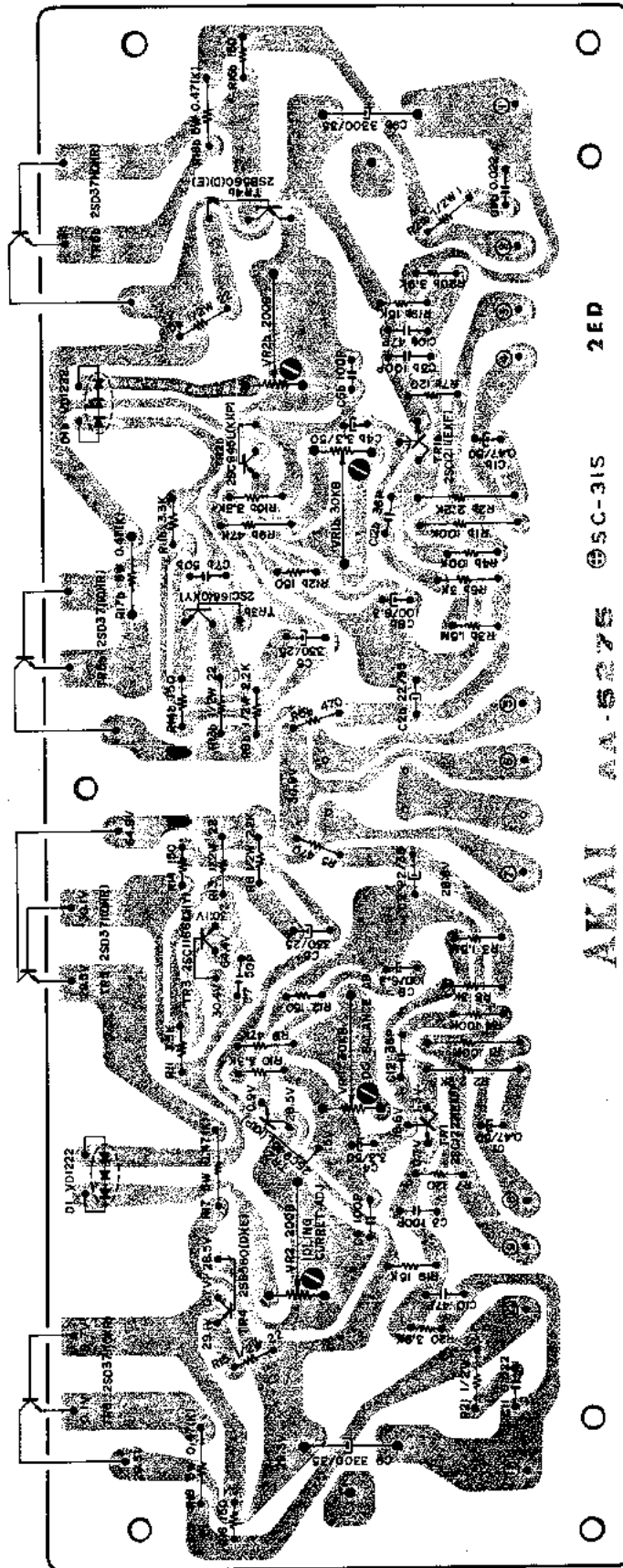

3) POWER SUPPLY P.C BOARD AA-5273

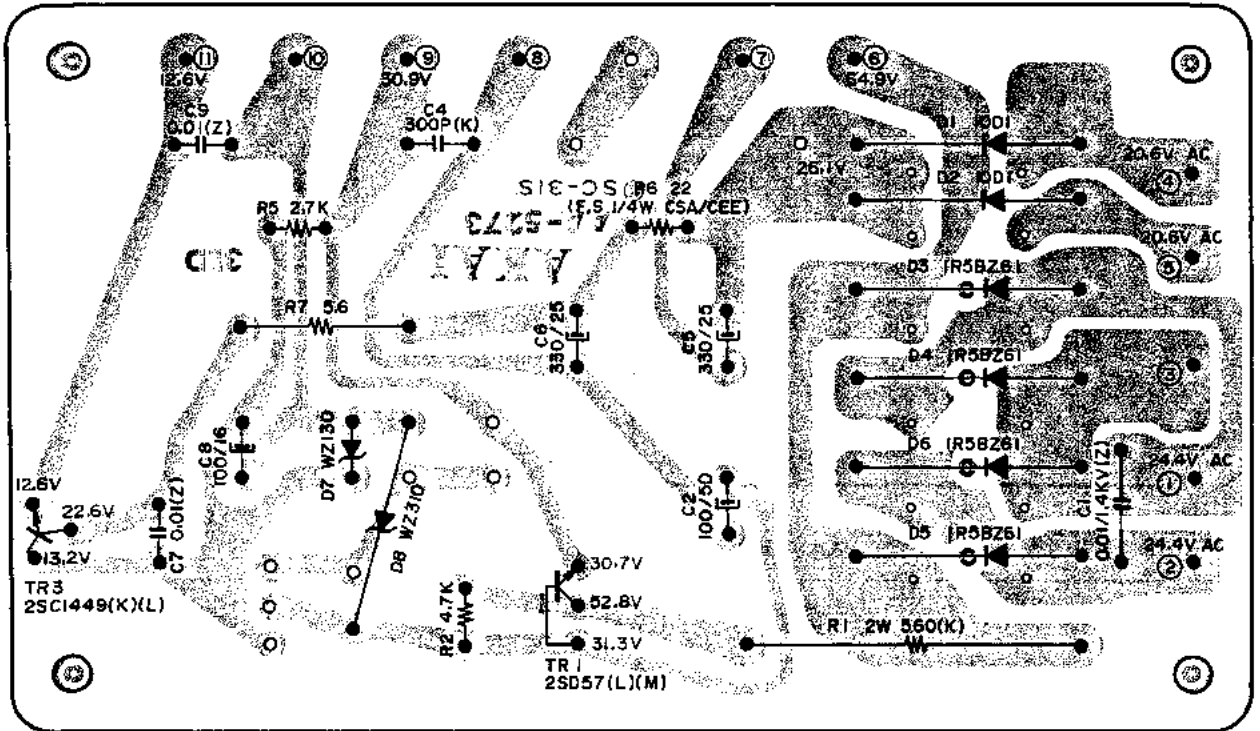

4) TONE CONTROL P.C BOARD AA-5295A

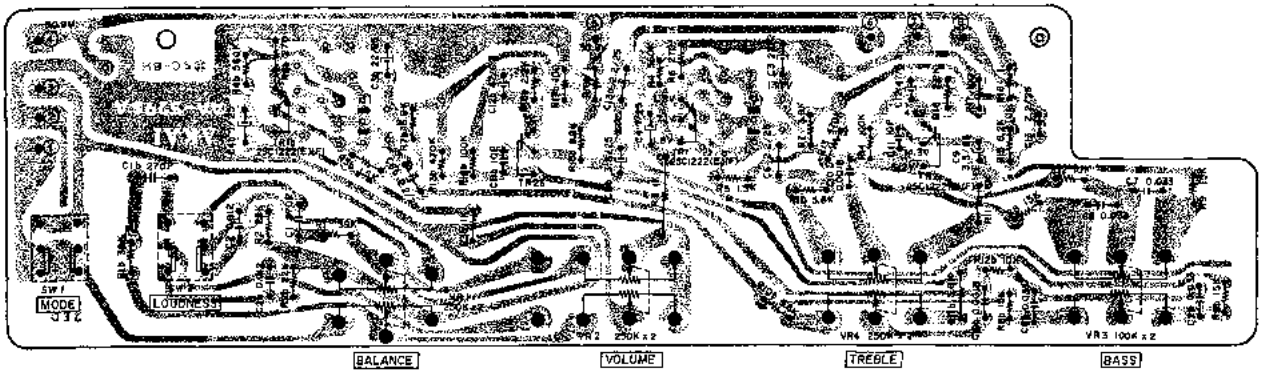

5) FILTER MUTE P.C BOARD AA-5276B

6) LED P.C BOARD AA-5270B

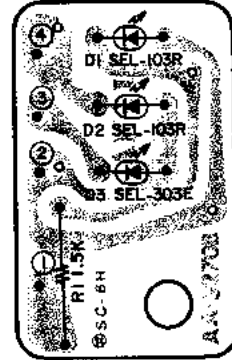
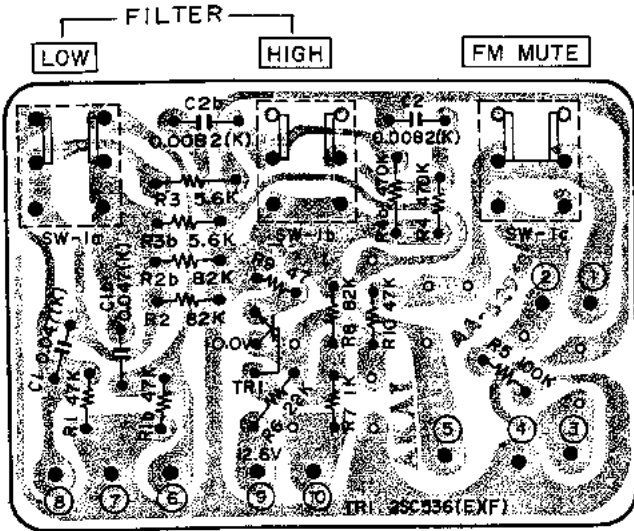

7) DOLBY N.R. P.C BOARD AA-5397

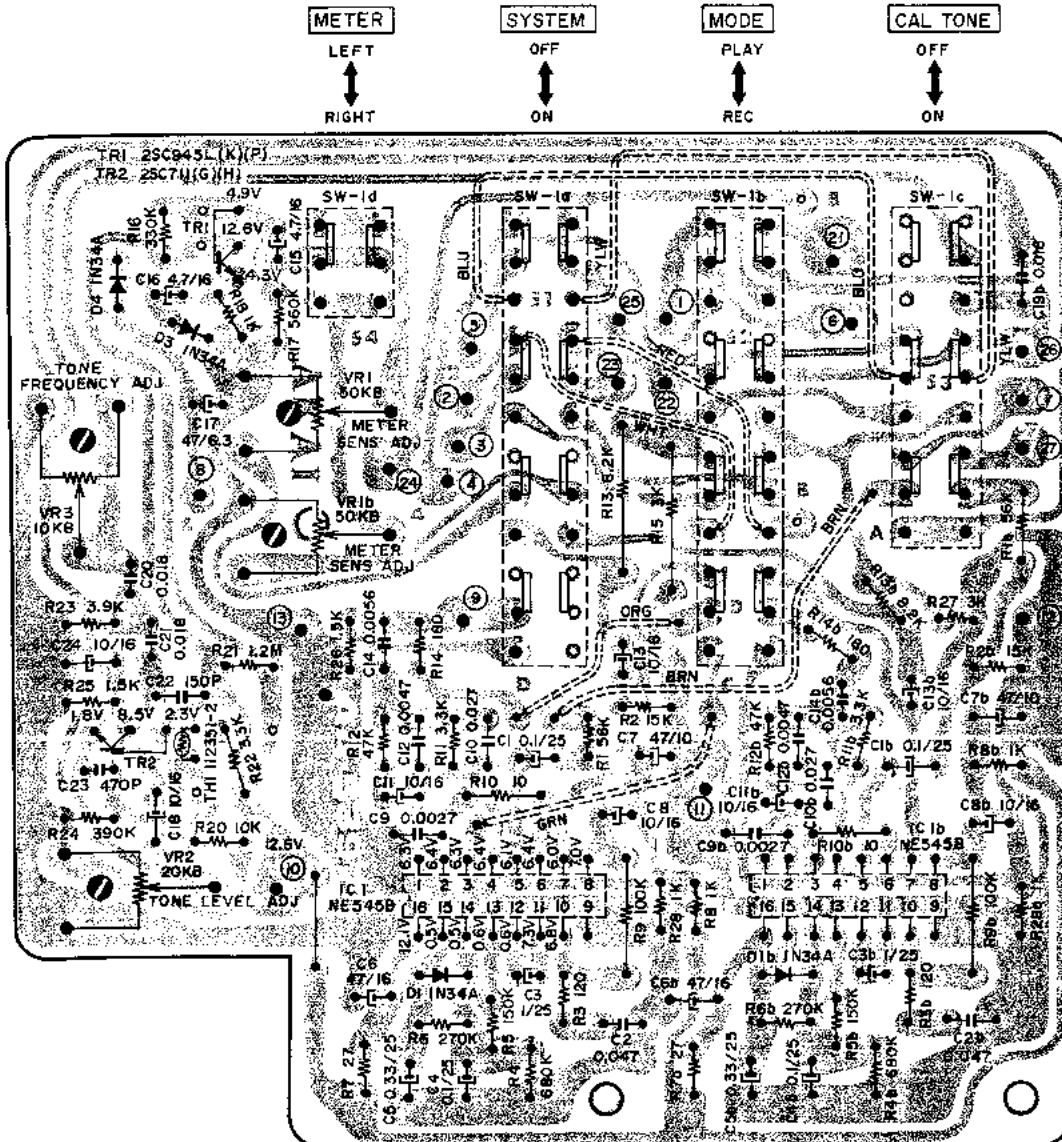

SECTION 2

PARTS LIST

The composite parts of Model AA-1020DB, except for those which have been changes as per the list below, are identical to those of Model AA-1020. Therefore, when ordering parts for this Model, please utilize Model AA-1020 Parts List.

HOW TO USE THIS PARTS LIST

1. This parts list is compiled by various individual blocks based on assembly process.
2. When ordering parts, please describe parts number, serial number, and model number in detail.
3. How to read list.

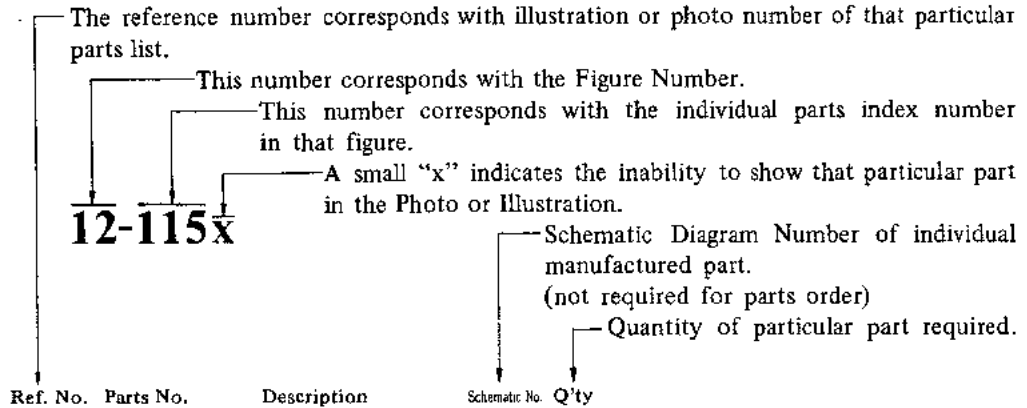

Ref. No.	Parts No.	Description	Schematic No.	Q'ty
FLYWHEEL BLOCK #13				
12-115x	800425	Flywheel Block Assy. Comp.	RDG #13	1
12-116	244506	Flywheel Only	RD-233	1
12-117x	244754	Felt, Flywheel	RD-275	1
12-118	251324	Main Metal Case	RD-336	1
12-119	253080	Main Metal	RD-237	1

4. The symbol numbers shown on the P.C. Board list can be matched with the Composite Views of components of the Schematic Diagram or Service Manual.
5. The indications of Resistors and Capacitors in the photos of P.C. Board are being eliminated.
6. The shape of the parts and parts name, etc. can be confirmed by comparing them with the parts shown on the Electrical Parts Table of P.C. Board.
7. Both the kind of part and installation position can be determined by the Parts Number. To determine where a parts number is listed, utilize Parts Index at end of Parts List.
It is necessary first of all to find the Parts Number. This can be accomplished by using the Reference Number listed at right of parts number in the Parts Index. (meaning of ref. no. outlined in Item 3 above).
8. Utilize separate "Price List for Parts" to determine unit price. The most simple method of finding parts Price is to utilize the reference number.

1 MULTI FUNCTION P.C BOARD (AA-5395A) BLOCK

Symbol No.	Parts No.	Description	Q'ty
1	BA680005	Multi Function P.C Board Comp. (AA-5395A)	1
IC1	EI650362	IC MPC-30C	1
IC2	EI650586	IC LA-1230	1
IC3	EI650597	IC LA-3350A	1
TR1,2	ET459810	Transistor 2SC1222(E)(F)	4
TR3	ET557965	Transistor 2SA733(Q)(R)	1
TR4	ET618873	Transistor 2SC930(E)(F)	1
TR5	ET635220	Transistor 2SC945L(K)(P)	1
D1,2	ED624903	Silicon Diode 1S2473	2
SW1	ES650294	Rotary SW. SR26N 4-13-6 22.5 KC	1
SW2	ES650305	Rotary SW. SR26N 2-4-5 22.5 KC	1
T1	E0650384	AM-IF Trans. CFU-085-D 468 kHz	1
T2	E0650395	OSC. Coil RWR-41498A	1
T3	E0650373	AM-IF Trans. RLC-41543A 468 kHz	1
T4	E0650608	Discri Coil MV4-FLC-20000	1
VR1	EV484863	Semi-fixed/Vol. V10K8-4-2 1 kB (Metalized Film)	1
VR2	EV499364	Semi-fixed/Vol. V10K8-4-2 5 kB	1
VR3	EV465017	Semi-fixed/Vol. V8K4-1 200 kB	1
L1	E0650610	Inductor 144LZ 18 μ H(J)	1
FL1,2	ER650430	Ceramic Filter SFE-10.7 MA-8-7	2
FL3	ER656908	Block Filter FB3201	1
2	EJ650272	Pin Jack 14P JPI379-1-1	1
3	TA648156	Switch Support	1
4	ZS422076	Screw, pan head 3x5	1
Capacitor, Vertical Type			
C11	EC516723	Styrol 270PF(K) 50WV	2
C12	EC650406	Styrol 310PF(J) 50WV	1
C43	EC666494	Styrol 1500PF(K) 50WV	1
C44	EC621257	Solid Aluminum 0.47 μ F(M) 25WV	1
C45	EC522167	Solid Aluminum 0.22 μ F(M) 25WV	1

2 DOLBY N.R. P.C BOARD (AA-5397) BLOCK

Symbol No.	Parts No.	Description	Q'ty
1	BA671534	Dolby N.R. P.C Board Comp. (AA-5397)	1
IC1	EI605013	IC NE545B	2
TR1	ET635220	Transistor 2SC945L(K)(O)	1
TR2	ET563905	Transistor 2SC711(G)(H)	1
D1,3,4	ED219464	Germanium Diode 1N34A	4
TH1	ED485370	Thermister 24D26	1
SW1	ES650518	Push SW. 4F0041FF2020	1
VR1	EV650891	Semi-fixed/Vol. V10K8-4-2 50 kB	2
VR2	EV560136	Semi-fixed/Vol. V10K8-4-2 20 kB	1
VR3	EV604438	Semi-fixed/Vol. V10K8-4-2 10 kB	1
Capacitor, Vertical Type			
C1,4	EC523282	Solid Aluminum/C. 0.1 μ F(M) 25WV	4
C5	EC604440	Solic Aluminum 0.33 μ F(M) 25WV	2
C23	EC516767	Styrol 470PF(K) 50WV	1

3 ASSEMBLY BLOCK & FINAL ASSEMBLY BLOCK

Parts No.	Description	Schematic No.	Q'ty
EV651093	FM CAL VR. V1614N6S 20 kB	36-6-13	2
EV651025	PLAY CAL VR. V16L4N 100 kB	36-6-14	2
EV650970	REC LEVEL VR. V16L4N 20KC 100 kB	36-6-15	2
SK646841	Single Knob (Small) (Rec Level)	AA-5254	2
EM664435	Level Meter 85C245	46-1-117	1
BD649315	Front Panel Block Comp.		1
SP646281	Rear Panel 1	AA-5310	1
SP648292	Rear Panel 2 (CEE)	AA-5310	1
SP679612	Rear Panel 1-A (CSA)	AA-5310	1

LIST OF INTERCAHNGEABLE SEMICONDUCTORS

As far as service in concerned, in case the original parts cannot be obtained, the interchangeable parts listed below can be substituted.

Original Parts			Interchangeable Parts	
Description	Parts No.	Utilizing P.C Board	Description	Parts No.
2SA733(Q)(R)	ET557965	AA-5395A		
2SB560(D)(E)	ET699028	AA-5275	2SA661(O)(Y)	ET650665
2SC711(G)(H)	ET563905	AA-5397	2SC945(E)(F)	ET398711
2SC536(E)(F)	ET342707	AA-5276B	2SC711(E) 2SC945L(K)(P)	ET380834 ET635220
2SC930(E)(F)	ET618873	AA-5395A		
2SC945L(K)(P)	ET635220	AA-5395A AA-5275 AA-5397	2SC711(E) 2SC536(E)(F) 2SC1647(R)(S)	ET380834 ET370607 ET658181
2SC1166(O)(Y)	ET650654	AA-5275	2SC1124(I)(2)	ET551564
2SC1222(E)(F)	ET459810	AA-5295A AA-5275 AA-5395A	2SC458LG(C) 2SC1000(Y)(GR) 2SC1313(G)(H)	ET523405 ET654862 ET604124
2SC1449(K)(L)	ET649034	AA-5273	2SD234(O)(Y) 2SD313(D)(E)	ET393568 ET556086
2SD371(O)(R)	ET650632	AA-5275	2SC1111(O)(Y)	ET556648
2SD571(L)(M)	ET655356	AA-5273	2SD234(O)(Y)	ET393568
NE545B	EI605013	AA-5397		
μPC30C	EI650362	AA-5395A		
LA1230	EI650586	AA-5395A		
LA3350A	EI650597	AA-5395A		
10D1	ED224526	AA-5273	1N4002 1N4003	ED511907 ED570295
1N34A	ED219464	AA-5397	1N60 1S1588AM	ED428264 ED562386
1R5BZ61	ED650621	AA-5273	HIFI Special 400V	ED558033
WZ130	ED539976	AA-5273		
WZ310	ED697195	AA-5273		
1S2473	ED624903	AA-5395A	1S1588	ED557447
SEL102R	ED650812	AA-5270B		
SEL302E	ED661443	AA-5270B		

SECTION 3

SCHEMATIC DIAGRAM

AA-1020DB

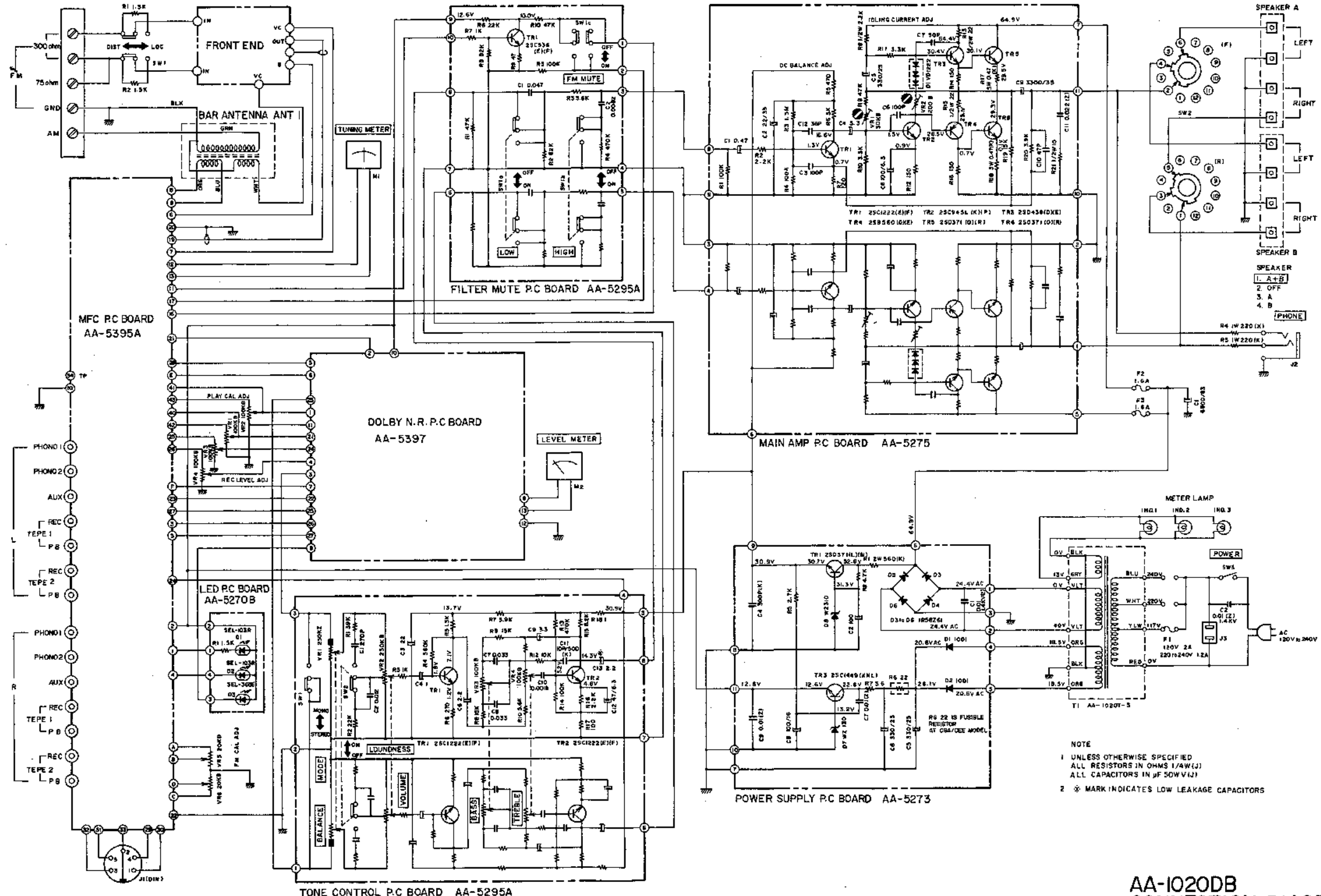

NOTE
 1 UNLESS OTHERWISE SPECIFIED
 ALL RESISTORS IN OHMS 1/4W(1/)
 ALL CAPACITORS IN μ F 50WV(1/)
 2 * MARK INDICATES LOW LEAKAGE CAPACITORS

AA-1020DB
 CONNECTION DIAGRAM
 NO. 4-1 1521040A

AA-1020DB

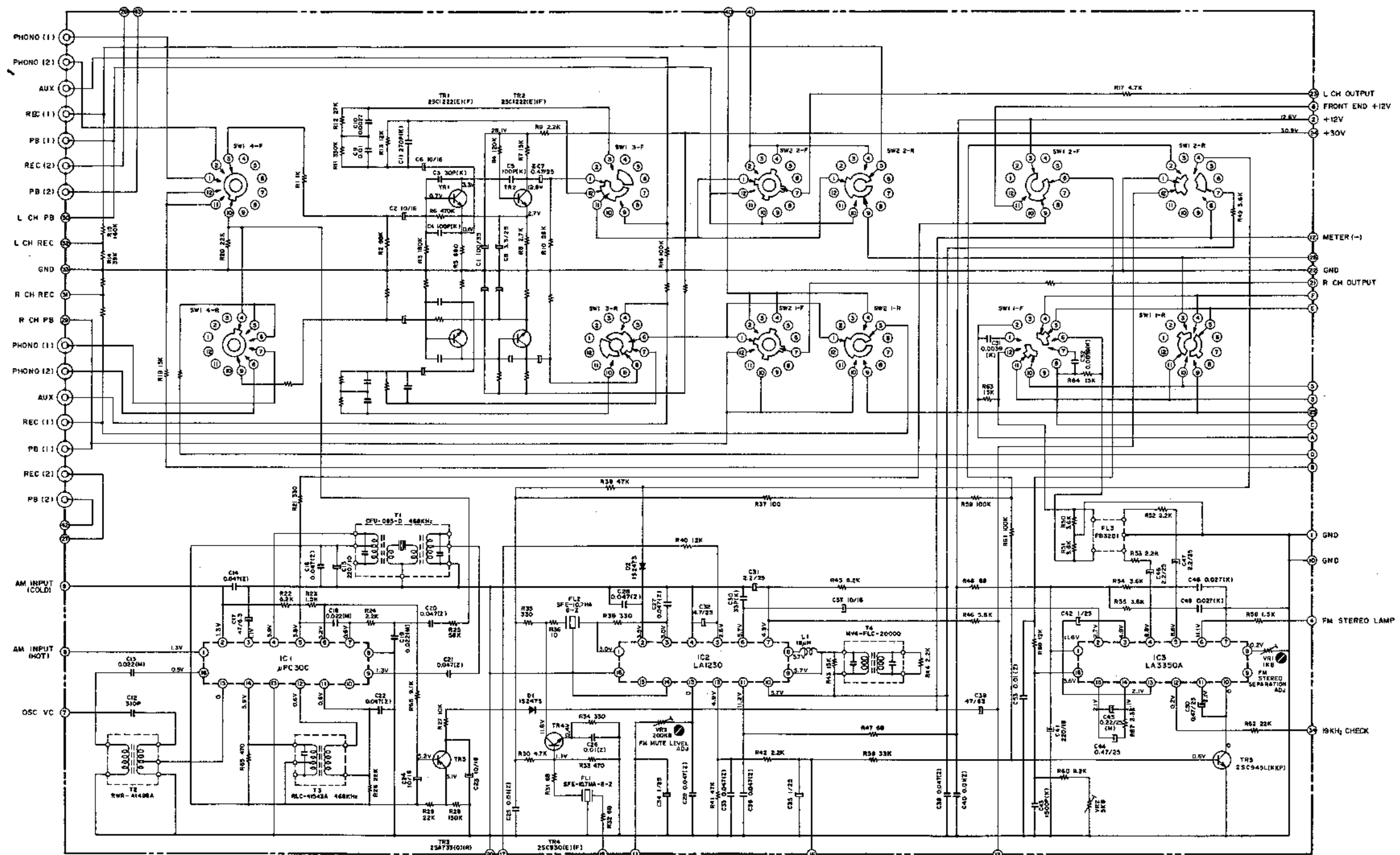

SWITCH POSITIONS

SW1 (SELECTOR)	SW2 (TAPE)
① AM	① 1-2
② FM DOLBY	② 1
③ FM AUTO	③ SOURCE
④ PHONO 1	④ 2
⑤ PHONO 2	⑤ 2-1
⑥ AUX	

NOTE
 1. UNLESS OTHERWISE SPECIFIED
 ALL RESISTORS IN OHMS 1/4W(1)
 ALL CAPACITORS IN μ F 50WV(1)
 2. * MARK INDICATES LOW LEAKAGE CAPACITORS

AA-1020DB
 MULTI FUNCTION
 SCHEMATIC DIAGRAM
 NO.4-2 1521041A
 2C

AA-1020DB

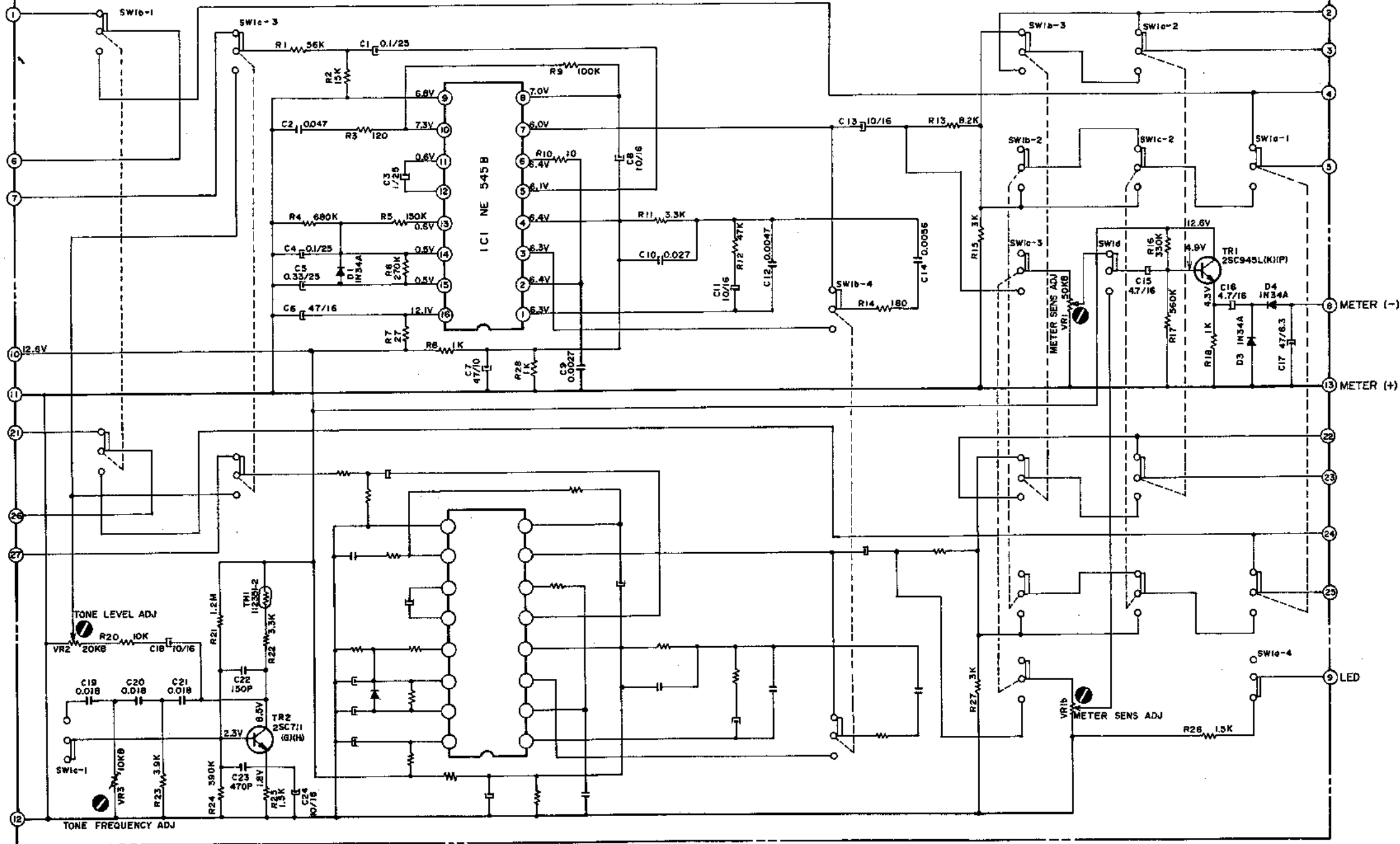

SW1a-1 to 4	DOLBY N.R.	OFF
SW1b-1 to 4	REC/RB	REC
SW1c-1 to 3	DOLBY TONE	OFF
SW1b	METER	Lch

NOTE
 1. UNLESS OTHERWISE SPECIFIED
 ALL RESISTORS IN OHMS 1/4W(J)
 ALL CAPACITORS IN µF 50WV(J)

AA-1020DB DOLBY NR.
 SCHEMATIC DIAGRAM
 NO.4-3 1521042A
 2C

AA-1020DB

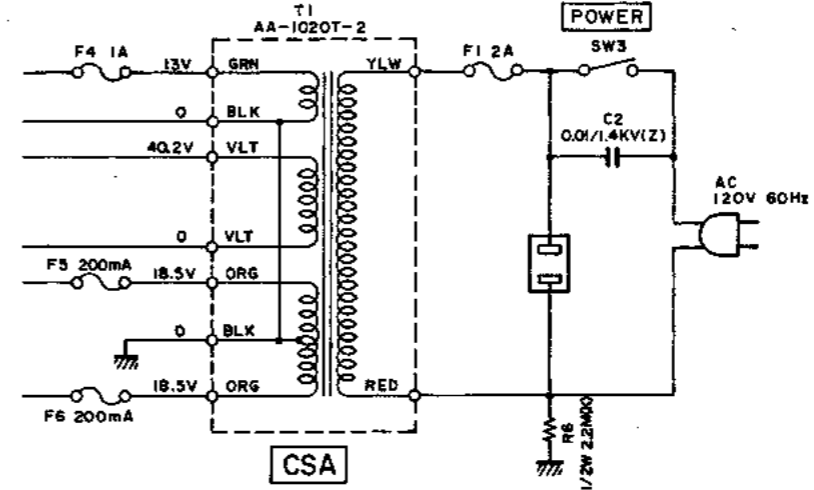
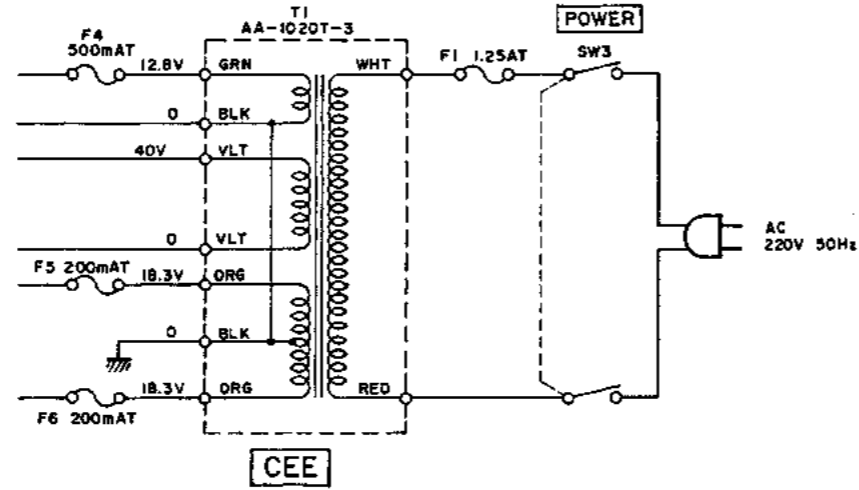

NOTE
POWER TRANSFORMER BLOCK IS
DIFFERENT ACCORDING TO AREA

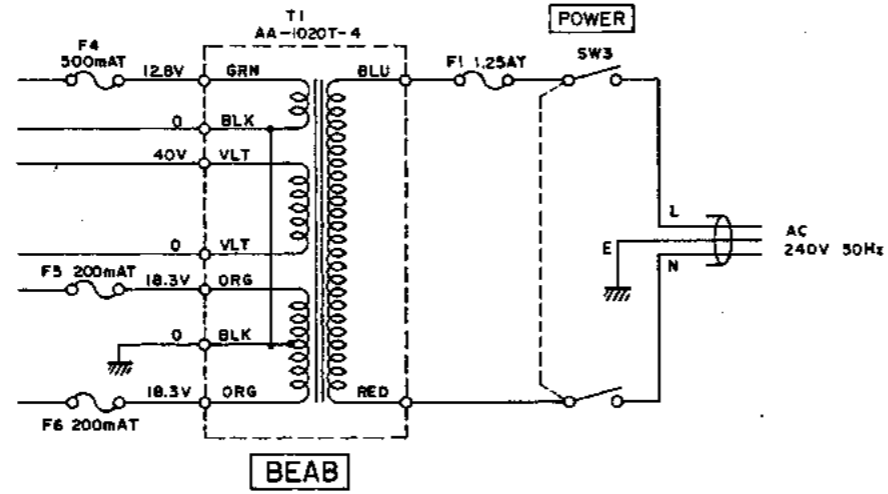

AA-1020DB
POWER TRANS
SCHEMATIC DIAGRAM
NO4-4 1521043A