

SERVICE MANUAL

PARTS LIST

AA-1115
MODEL AA-1125

AKAI

ALSO APPLICABLE TO BLACK MODEL

AA-1115

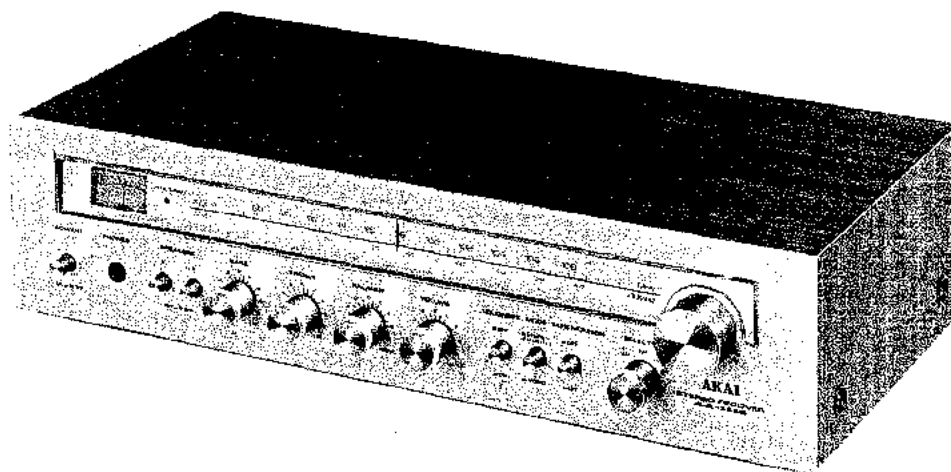

AA-1115

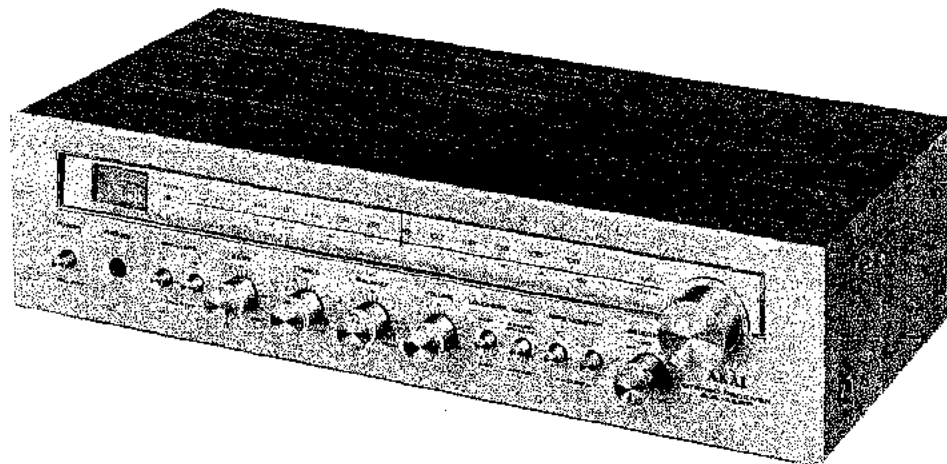

AA-1125

AKAI STEREO RECEIVER

AA-1115
MODEL **AA-1125**

ALSO APPLICABLE TO BLACK MODEL

SECTION 1	SERVICE MANUAL	3
SECTION 2	PARTS LIST	29
SECTION 3	SCHEMATIC DIAGRAM	44

SECTION 1

SERVICE MANUAL

TABLE OF CONTENTS

I.	TECHNICAL DATA	4
II.	DISMANTLING OF UNIT	6
III.	CONTROLS	7
	1. MODEL AA-1115	7
	2. MODEL AA-1125	8
IV.	PRINCIPAL PARTS LOCATION	9
	1. MODEL AA-1115	9
	2. MODEL AA-1125	10
V.	OPERATING PRINCIPLES OF QUADRATURE DETECTION SYSTEM ..	11
VI.	OPERATING PRINCIPLES OF PLL CIRCUIT EMPLOYED	
	IN STEREO DEMODULATION CIRCUIT	12
	1. PLL CIRCUIT OPERATION	12
	2. STEREO DEMODULATION CIRCUIT	12
VII.	LEVEL DIAGRAM	14
	1. MODEL AA-1115	14
	2. MODEL AA-1125	15
VIII.	TUNER ADJUSTMENT	16
	1. FM SECTION ADJUSTMENT	17
	2. AM SECTION ADJUSTMENT	18
IX.	MAIN AMPLIFIER ADJUSTMENT	19
X.	TUNING CORD THREADING	21
XI.	CLASSIFICATION OF VARIOUS P.C BOARDS	22
	1. RELATION OF P.C BOARD TITLE AND	
	IDENTIFICATION NUMBER	22
	2. COMPOSITION OF VARIOUS P.C BOARDS	23

For basic adjustments measuring methods, and operating principles, refer to GENERAL OPERATING PRINCIPLES AND ADJUSTMENTS.

I. TECHNICAL DATA

AMPLIFIER SECTION

		AA-1115	AA-1125
POWER OUTPUT		15 watts per channel, min. RMS, at 8 ohms from 40 to 20,000 Hz with no more than 0.5% T.H.D.	25 watts per channel, min. RMS, at 8 ohms from 20 to 20,000 Hz with no more than 0.3% T.H.D.
POWER BANDWIDTH (IHF)		15 Hz to 40 kHz T.H.D. 0.5% at 8 ohms	15 kHz to 40 kHz T.H.D. 0.3% at 8 ohms
S/N RATIO (IHF)	PHONO AUX	Better than 75 dB Better than 90 dB	Better than 75 dB Better than 90 dB
RESIDUAL NOISE		Less than 0.8mV at 8 ohms	Less than 0.8mV at 8 ohms
CHANNEL SEPARATION (IHF)	PHONO	Better than 50 dB at 1 kHz	Better than 50 dB at 1 kHz
DAMPING FACTOR		More than 30 (1 kHz, 8 ohms)	More than 30 (1 kHz, 8 ohms)
OUTPUT	SPEAKERS HEADPHONES	A, B (4 to 16 ohms) A+B (8 to 16 ohms) 4 to 16 ohms	A, B (4 to 16 ohms) A+B (8 to 16 ohms) 4 to 16 ohms
INPUT SENSITIVITY/IMPEDANCE	PHONO AUX	3 mV/47 kohms 150 mV/100 kohms	3 mV/47 kohms 150 mV/100 kohms
TAPE MONITOR	1) INPUT	PIN: 150 mV/100 kohms DIN: 150 mV/100 kohms	PIN: 150 mV/100 kohms DIN: 150 mV/100 kohms
	OUTPUT	PIN: 150 mV/100 kohms DIN: 30 mV/180 kohms	PIN: 150 mV/100 kohms DIN: 30 mV/180 kohms
	2) INPUT		PIN: 150 mV/100 kohms
	OUTPUT		PIN: 150 mV/100 kohms
FREQUENCY RESPONSE	PHONO (RIAA) AUX/TAPE MONITOR	30 Hz to 15 kHz ± 1 dB 10 Hz to 70 kHz +0 dB, -2 dB	30 Hz to 15 kHz ± 1 dB 10 Hz to 70 kHz +0 dB, -2 dB
TONE CONTROL	BASS TREBLE	± 9 dB at 100 Hz ± 9 dB at 10 kHz	± 9 dB at 100 Hz ± 9 dB at 10 kHz
LOUDNESS CONTROL		+10 dB at 100 Hz, +5 dB at 10 kHz (Volume control set at -30 dB position)	+10 dB at 100 Hz, +5 dB at 10 kHz (Volume control set at -30 dB position)

TUNER SECTION

FM

		AA-1115	AA-1125
FREQUENCY RANGE		88 MHz to 108 MHz	88 MHz to 108 MHz
SENSITIVITY (IHF)		1.9 μ V	1.9 μ V
CAPTURE RATIO		1.3 dB	1.3 dB
SELECTIVITY (IHF)		More than 60 dB	More than 70 dB
IMAGE REJECTION		More than 65 dB (at 98 MHz)	More than 65 dB (at 98 MHz)
IF REJECTION		More than 90 dB (at 98 MHz)	More than 90 dB (at 98 MHz)
SPURIOUS REJECTION		More than 90 dB (at 98 MHz)	More than 90 dB (at 98 MHz)
AM SUPPRESSION		50 dB	50 dB
S/N RATIO		65 dB	65 dB
HARMONIC DISTORTION	MONO	Less than 0.3% (100% Mod.)	Less than 0.3% (100% Mod.)
	STEREO	Less than 0.6% (100% Mod.)	Less than 0.6% (100% Mod.)
STEREO SEPARATION		More than 40 dB at 1 kHz	More than 40 dB at 1 kHz
SUBCARRIER SUPPRESSION		More than 52 dB	More than 52 dB

AM

	AA-1115	AA-1125
FREQUENCY RANGE	520 kHz to 1,605 kHz	520 kHz to 1,605 kHz
SENSITIVITY (IHF)	180 μ V/m (Bar antenna) 10 μ V (External antenna)	180 μ V/m (Bar antenna) 10 μ V (External antenna)
SELECTIVITY (IHF)	More than 30 dB	More than 30 dB
IMAGE REJECTION	More than 65 dB at 1 kHz	More than 65 dB at 1 kHz
IF REJECTION	More than 45 dB	More than 45 dB
S/N RATIO	More than 45 dB	More than 45 dB
TUNING INDICATOR METER	FM Center Tuning/AM Signal Strength Meter	FM Center Tuning/AM Signal Strength Meter
MUTING LEVEL CONTROL	ON (Stereo)/OFF (Monaural) Switch	ON (Stereo)/OFF (Monaural) Switch
ANTENNA INPUT IMPEDANCE	300 ohms balanced, 75 ohms unbalanced	300 ohms balanced, 75 ohms unbalanced

MISCELLANEOUS

	AA-1115	AA-1125
TRANSISTORS	25	27
DIODES	10	12
FET	1	1
ICs	4	4
POWER REQUIREMENTS	U.S.A. & Canada models: 120V, 60 Hz CEE models: 220V, 50 Hz Other models: 110/220/240V switchable, 50/60Hz	U.S.A & Canada models: 120V, 60 Hz CEE models: 220V, 50 Hz Other models: 110/220/240V switchable, 50/60 Hz
DIMENSIONS	480(W) \times 128(H) \times 268(D) mm, (18.9 \times 4.8 \times 10.6 inches)	480(W) \times 128(H) \times 268(D) mm, (18.9 \times 4.8 \times 10.6 inches)
WEIGHT	5.8 kg (12.8 lbs)	6.8 kg (15 lbs)

* For improvement purposes, specifications and design are subject to change without notice.

II. DISMANTLING OF UNIT

In case of trouble, etc. necessitating disassembly, please disassemble in the order shown in photographs. Reassemble in reverse order.

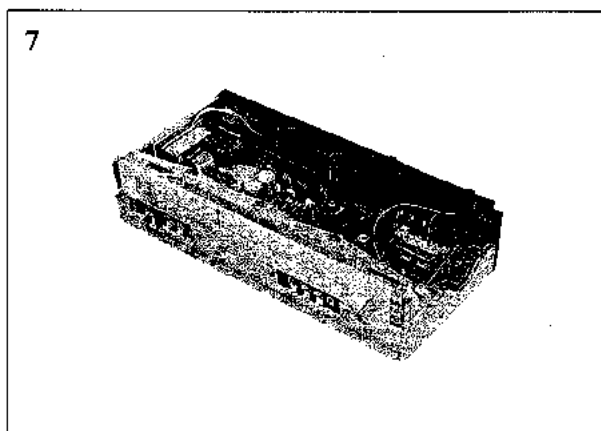
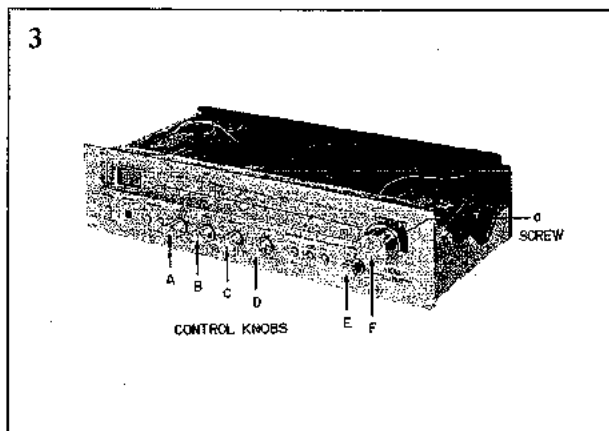
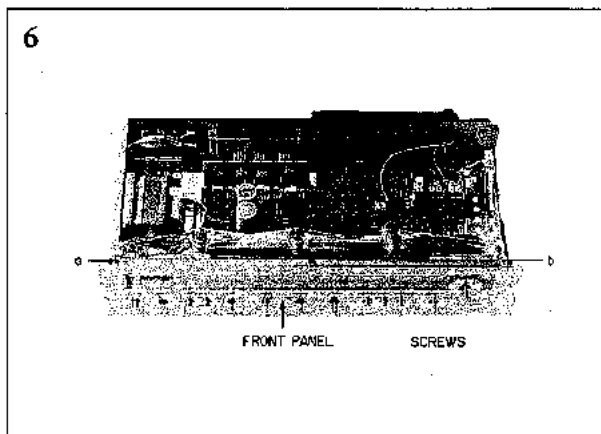
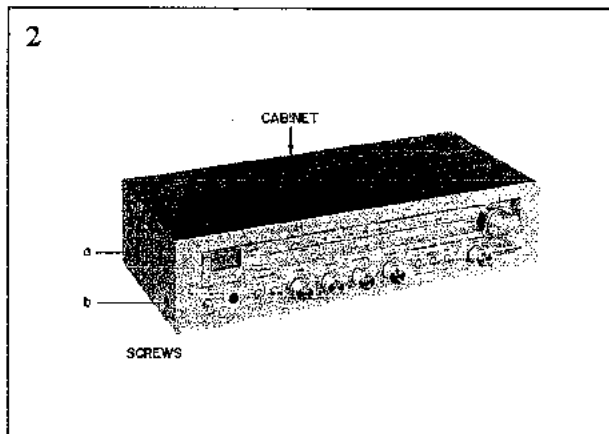
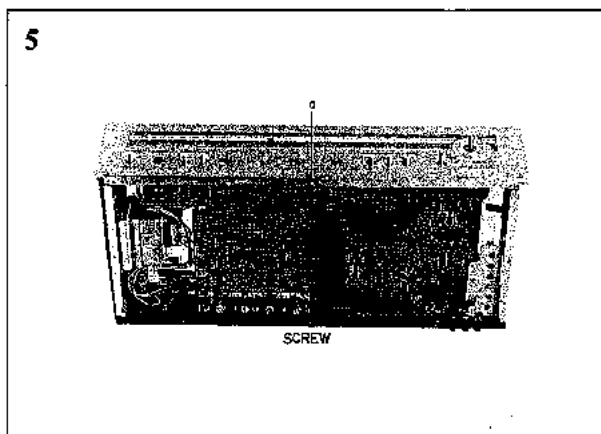
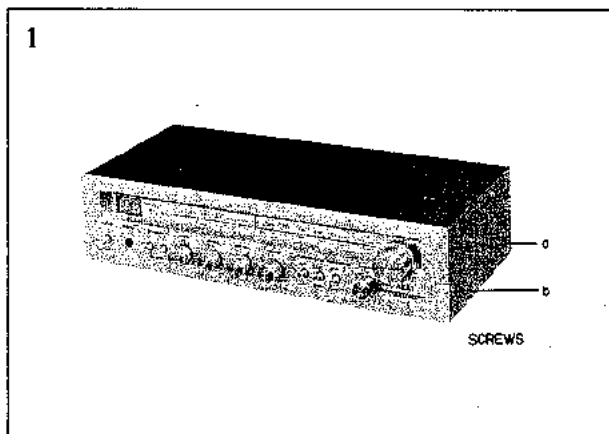
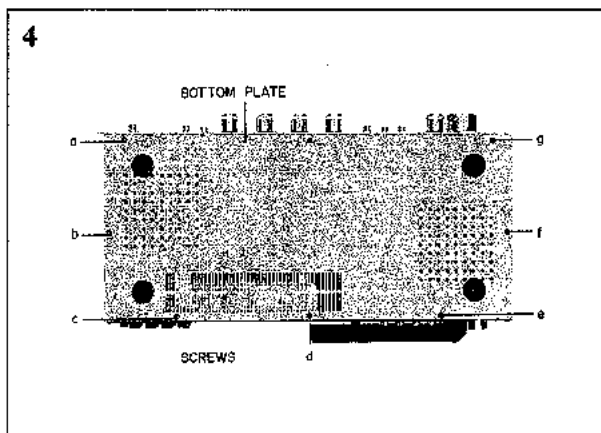

III. CONTROLS

1. MODEL AA-1115

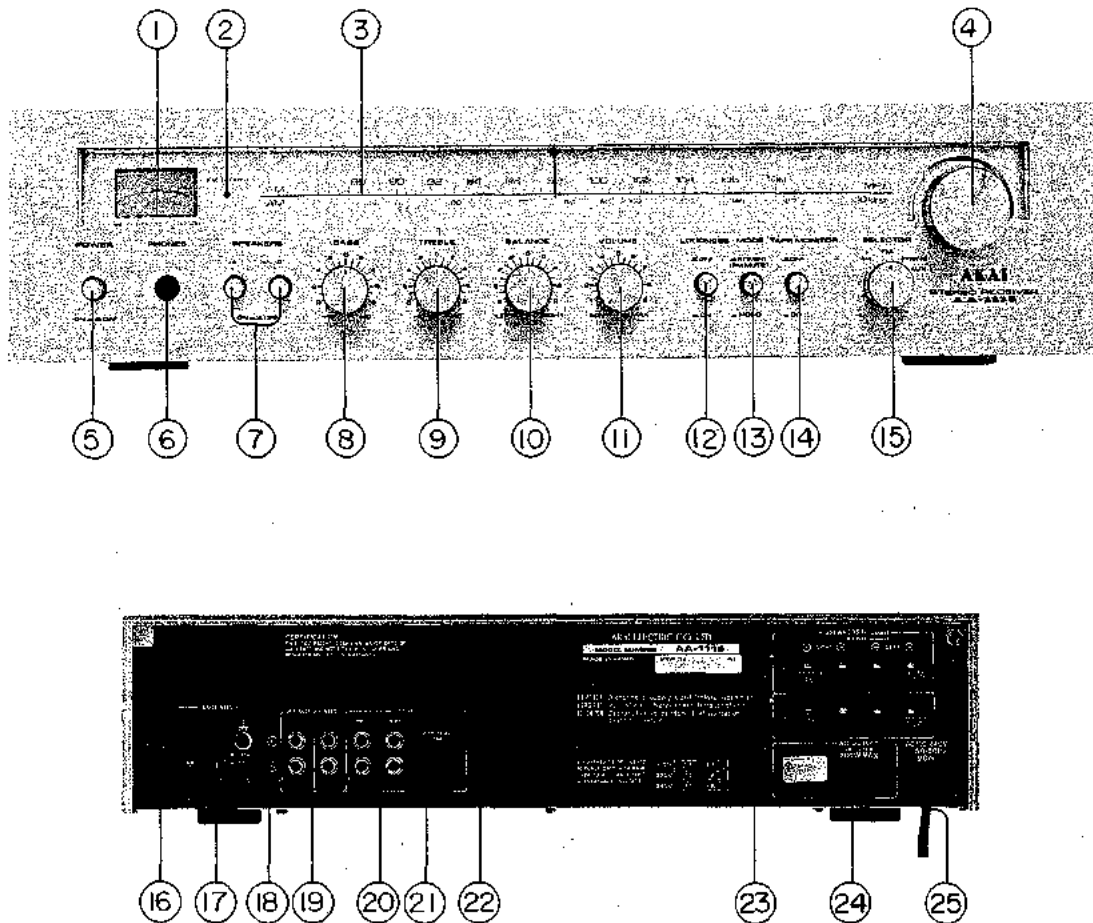

Fig. 1 Controls

- | | |
|-----------------------------|--|
| 1. FM/AM TUNING METER | 14. TAPE MONITOR SWITCH |
| 2. FM STEREO INDICATOR LAMP | 15. SOURCE SELECTOR |
| 3. DIAL SCALES | 16. AM FERRITE BAR ANTENNA |
| 4. TUNING KNOB | 17. AM AND FM ANTENNA TERMINALS |
| 5. POWER SWITCH | 18. PHONO JACKS |
| 6. HEADPHONE JACK | 19. AUX JACKS |
| 7. SPEAKER SWITCHES | 20. TAPE REC JACKS |
| 8. BASS CONTROL | 21. TAPE PB (PLAY) JACKS |
| 9. TREBLE CONTROL | 22. DIN JACK |
| 10. STEREO BALANCE CONTROL | 23. A AND B SPEAKER SYSTEM TERMINALS |
| 11. VOLUME CONTROLS | 24. AC OUTLET (CEE models not equipped with this facility) |
| 12. LOUDNESS SWITCH | 25. AC CORD (CEE models is equipped with an AC Inlet instead of an AC cord. Connect with an appropriate power cord.) |
| 13. MODE SWITCH | |

2. MODEL AA-1125

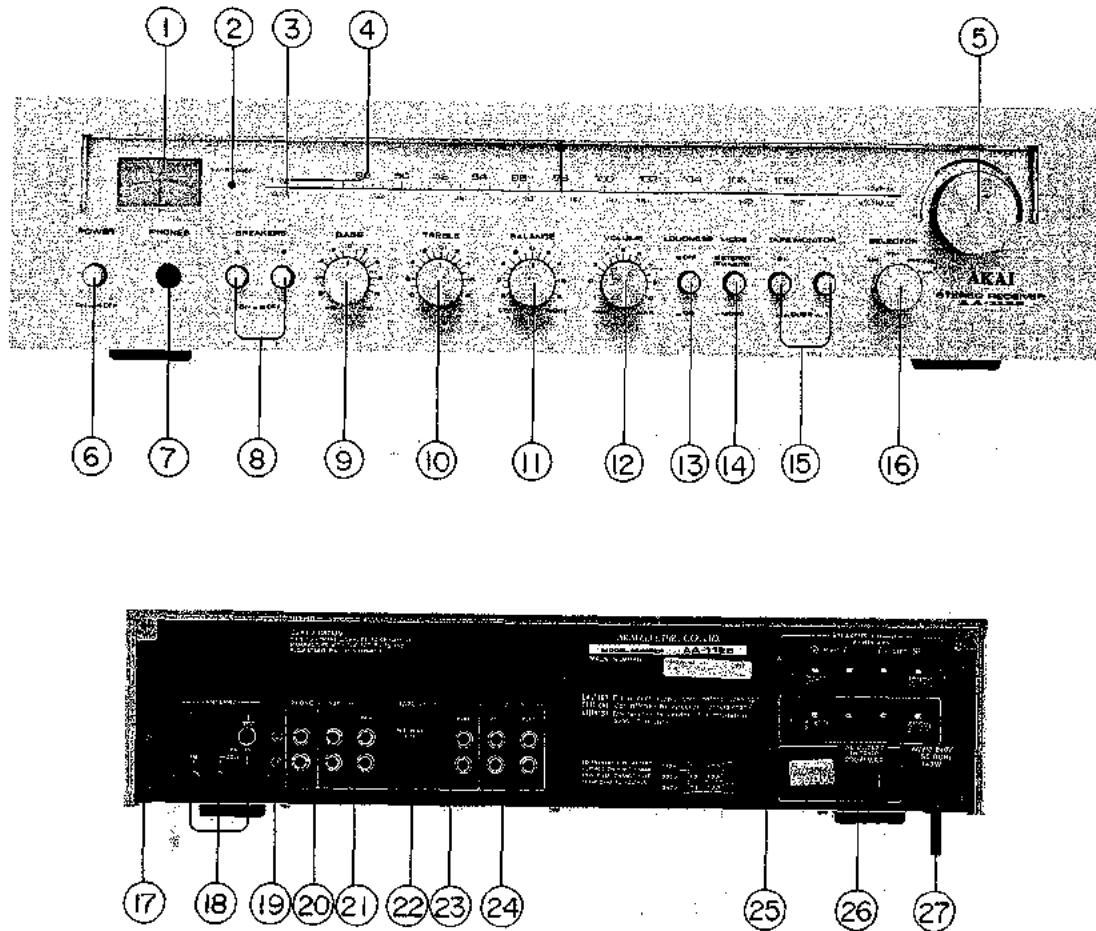

Fig. 2 Controls

- | | |
|-----------------------------|---|
| 1. AM/FM TUNING METER | 15. TAPE MONITOR SWITCHES |
| 2. FM STEREO INDICATOR LAMP | 16. SOURCE SELECTOR |
| 3. AM DIAL SCALE | 17. AM FERRITE BAR ANTENNA |
| 4. FM DIAL SCALE | 18. AM AND FM ANTENNA TERMINALS |
| 5. TUNING KNOB | 19. PHONO JACKS |
| 6. POWER SWITCH | 20. AUX JACKS |
| 7. HEADPHONE JACK | 21. TAPE 1 SYSTEM REC JACKS |
| 8. SPEAKER SWITCHES | 22. TAPE 1 SYSTEM DIN JACK |
| 9. BASS CONTROL | 23. TAPE 1 SYSTEM PLAY JACKS |
| 10. TREBLE CONTROL | 24. TAPE 2 SYSTEM REC/PLAY JACKS |
| 11. STEREO BALANCE CONTROL | 25. A AND B SPEAKER SYSTEM TERMINALS |
| 12. VOLUME CONTROL | 26. AC OUTLET (CEE models not equipped with this facility) |
| 13. LOUDNESS SWITCH | 27. AC CORD (CEE model is equipped with an AC Inlet instead of an AC cord. Connect with an appropriate power cord.) |
| 14. MODE SWITCH | |

IV. PRINCIPAL PARTS LOCATION

1. MODEL AA-1115

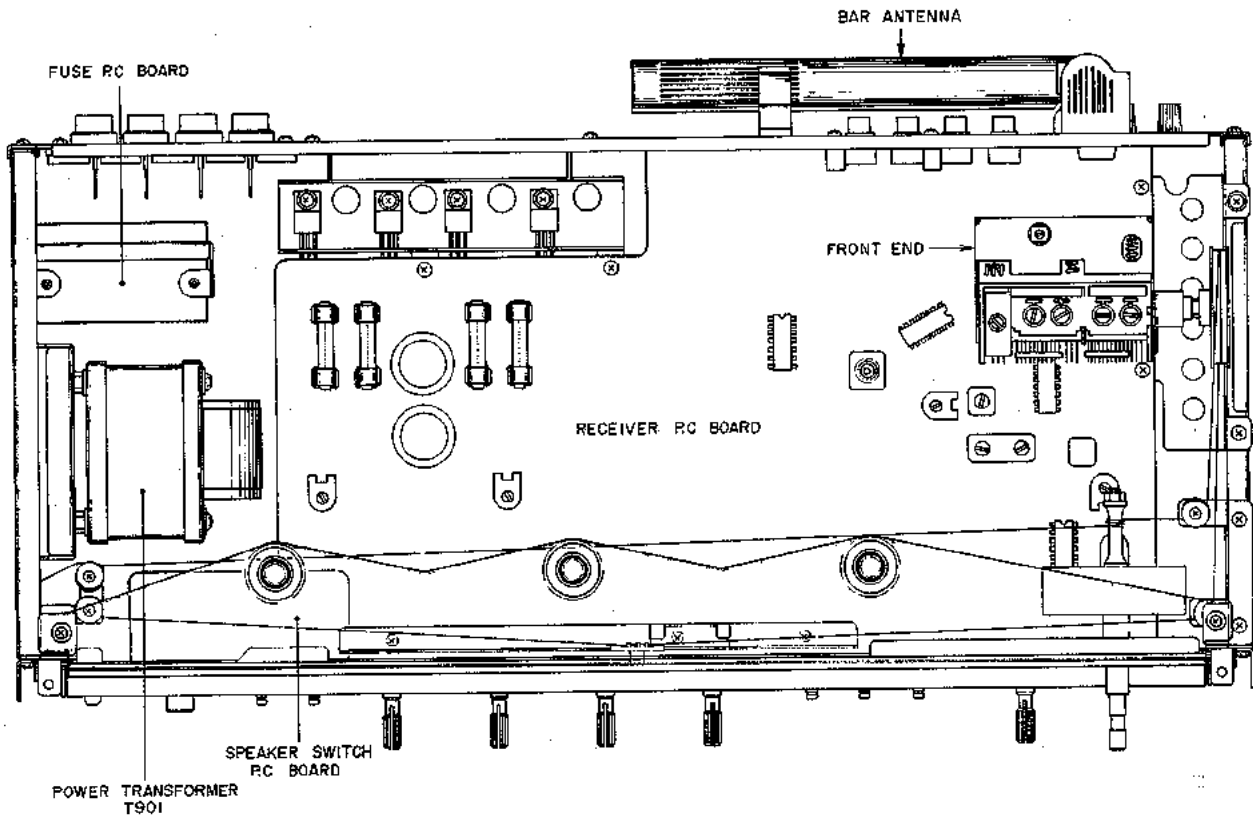

Fig. 3 Top View

NOTE:

	Receiver P.C Board	Fuse P.C Board	Speaker Switch P.C Board	LED P.C Board	Coil P.C Board
U/T, CSA, AAL	AB-1501A	AB-1501B only U/T	AB-1501C	AB-1501D	AB-1501E Except for U/T
CEE, BEAB	AB-1530A	AB-1530B	AB-1530C	AB-1530D	AB-1530E

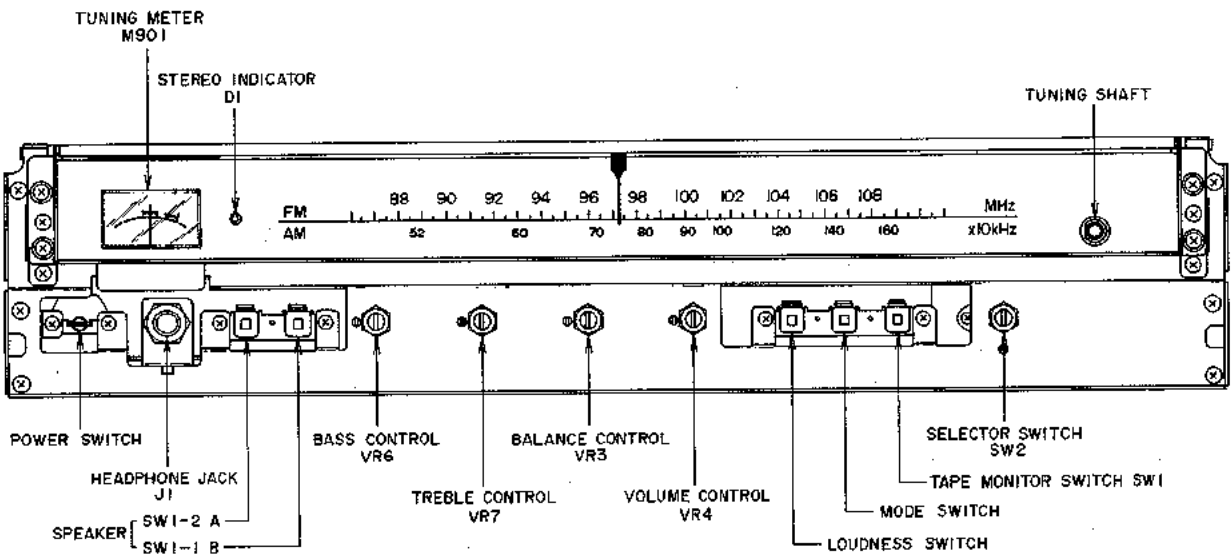

Fig. 4 Front View

2. MODEL AA-1125

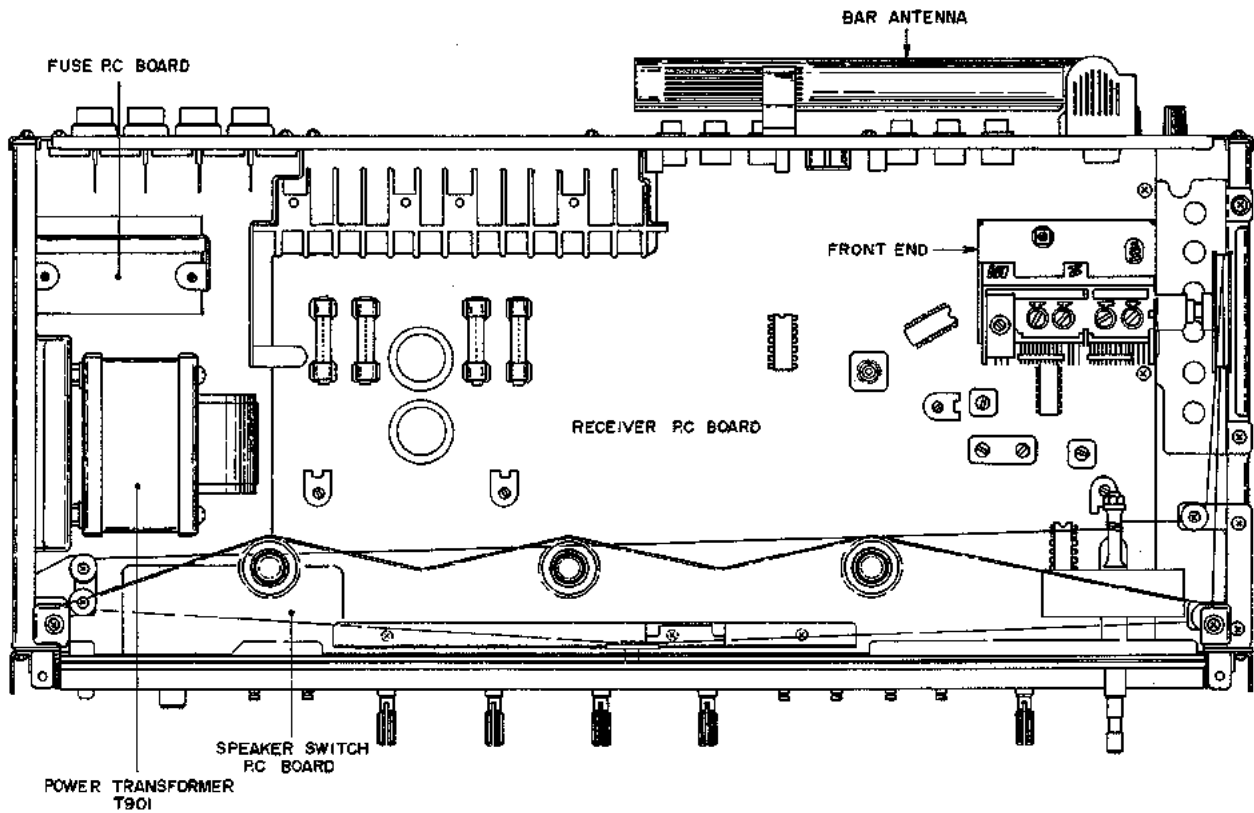

Fig. 5 Top View

NOTE:

	Receiver P.C Board	Fuse P.C Board	Speaker Switch P.C Board	LED P.C Board	Coil P.C Board
U/T, CSA, AAL	AB-2501A	AB-2501B only U/T	AB-2501C	AB-2501D	AB-2501E Except for U/T
CEE, BEAB	AB-2513A	AB-2513B	AB-2513C	AB-2513D	AB-2513E

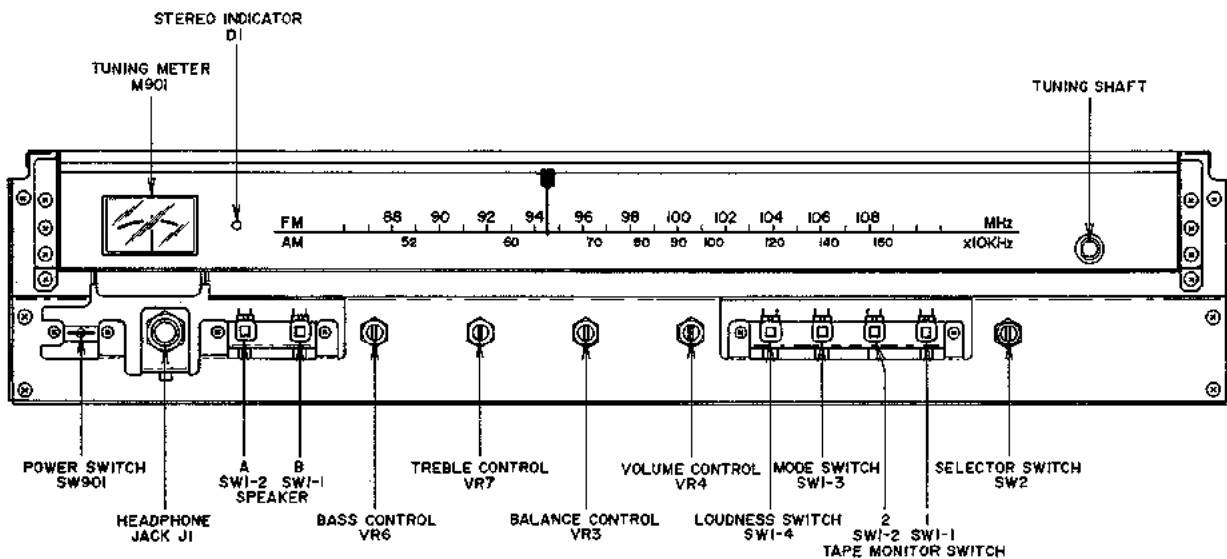

Fig. 6 Front View

V. OPERATING PRINCIPLES OF QUADRATURE DETECTION SYSTEM

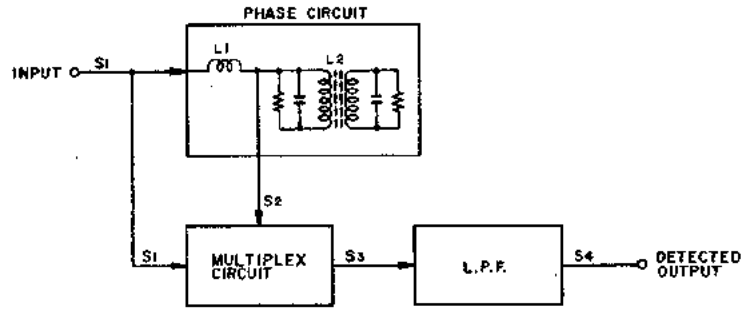

Fig. 7 Quadrature Detection Block Diagram

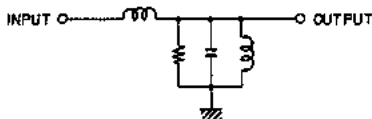

Fig. 8 Single Tuning Type

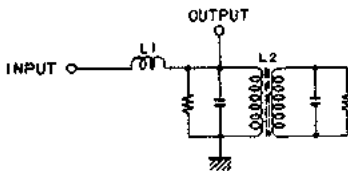

Fig. 9 Double Tuning Type

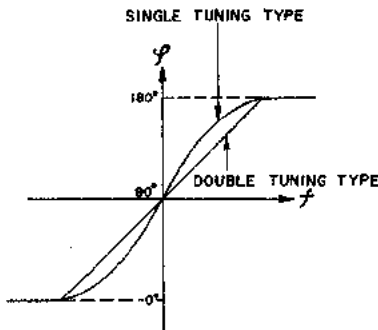

Fig. 10 Tuning Curve

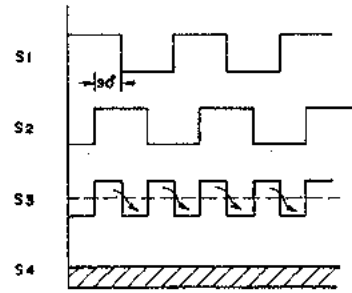

Fig. 11 Output at Non-modulation

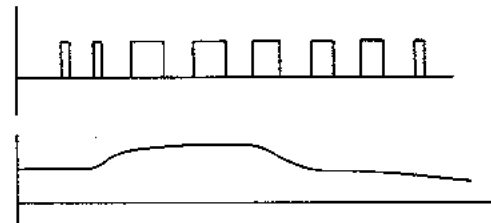

Fig. 12 Output at Modulation Time

The Quadrature Detection Circuit is comprised of a Phase Circuit, a Multiplier Circuit and a Low Pass Filter (L.P.F.) as shown in Fig. 7.

There are two types of Phase Circuits, the Single tuning type shown in Fig. 8 and the Double tuning type shown in Fig. 9. However, because with the double tuning type there is less frequency deviation in relation to carrier frequency, linearity is improved as shown in Fig. 10 and phase distortion is reduced, this type phase circuit is employed in the AA-1115 and AA-1125.

Input signal S_1 is divided into the part which enters the direct multiplier circuit and the part which passes the phase circuit and enters the multiplier circuit. The signal supplied to the phase circuit is always 90° phase delayed at L_1 . Also because at Non-modulation time, L_2 is tuned to 10.7 MHz, if modulation is applied and S_1 is changed from 10.7 MHz, phase deviation at L_2 will take place proportionately in relation to this changed part and this becomes S_2 signal which is delayed in relation to S_1 .

At Non-modulation, because as shown in Fig. 11, input signal S_1 and 90° phase delayed (by means of L_1) signal S_2 are switched by means of the multiplier circuit, the output signal becomes S_3 .

Because this S_3 passes the low pass filter and becomes S_4 fixed direct current, the detector output is zero. Then, when modulation is applied, because the switched output is varied according to the degree of modulation, and the output which passed the low pass filter becomes the pulsating current part as shown in Fig. 12, detector output is obtained.

VI. OPERATING PRINCIPLES OF PLL CIRCUIT EMPLOYED IN STEREO DEMODULATION CIRCUIT

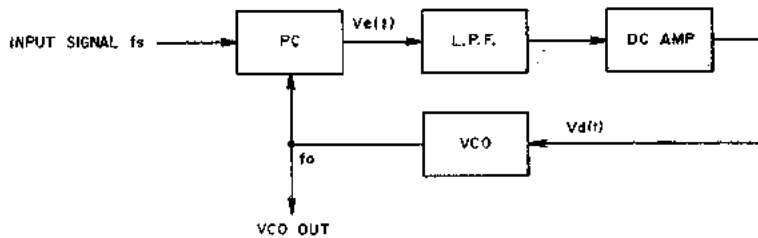

Fig. 13 PLL Circuit

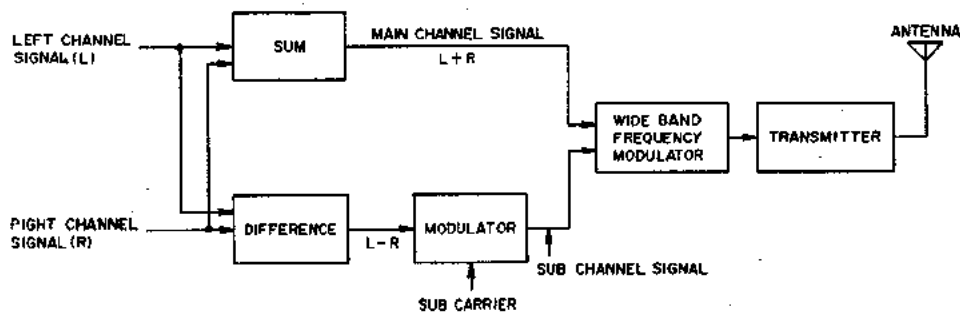

Fig. 14 FM Broadcasting System Diagram

To separate FM stereo broadcast signal received to date into left and right signals, a 19 kHz pilot signal was successively multiplier to form a 38 kHz signal and stereo separation was effected from this. However, with this multiplier system, change in coils due to wear occurred and adjustment points were numerous, etc. Therefore, this model employs a newly developed PLL circuit which produces an exceedingly accurate 38 kHz switching signal.

1. PLL CIRCUIT OPERATION

PLL circuit is a kind of feedback circuit and is comprised of a Phase Comparator (PC), a Low Pass Filter (LPF), a Direct Current Amplifier (DC Amp.) and a Voltage Control Oscillator (VCO) as shown in Fig. 13. The PC compares input signal F_s and VCO oscillator output and generate the difference in signal voltage $V_e(t)$ proportionately to this phase deviation. This $V_e(t)$ passes LPF and the DC Amp. and becomes control voltage. This control voltage supplied to VCO and VCO oscillation frequency is DC controlled. When there is no input signal F_s , because there is also no $V_e(t)$, control voltage $V_d(t)$ becomes zero, and VCO maintains a *Free-running oscillation frequency. When a signal enters, VCO oscillation frequency F_o is controlled to narrow the difference between F_s by means of feedback as described above, and the PLL circuit assumes a synchronous condition. This is referred to as input signal lock. (In case the difference between F_o and F_s is too large, the differential signal frequency becomes high and is reduced at the LPF. However, because the VCO control voltage does not change, PLL will not stay within the *lock range). Because of the ability of the signal interference removing LPF to accumulate the previous voltage in case the PLL deviates from within the lock range due

to certain interference, the original condition is quickly reinstated.

- * Free running frequency: Oscillating frequency when there is no input signal.
- * Lock range: At the condition in which the VCO oscillation frequency is locked to the input signal, the lock range is the oscillating frequency in which when the input signal changes, the PLL maintains it's input signal lock condition.

Accordingly, in case F_s is changed inside the PLL lock range, VCO oscillation frequency always follows this, and a no frequency deviation and no phase difference signal is obtained. In other words, VCO oscillation frequency can be locked to F_s .

2. STEREO DEMODULATION CIRCUIT

As shown in Fig. 14 for FM broadcasts, the sum signal (L+R) consists of left signal (L) and right signal (R) and the audio frequency band of this signal in its original form is frequency modulated.

On the other hand, the difference signal of both (L-R) is changed to high frequency through the use of the sub carrier, and is referred to as the sub channel signal. The carrier is further frequency modulated and sent to the FM stereo transmitter. Accordingly, for composite stereo signal demodulation, the sub carrier used for demodulation at the transmitter must be the same uniform 38 kHz signal as the frequency and phase. If the 38 kHz waveform is asymmetrical, channel separation will become poor. At the PLL employed MPX stereo demodulator circuit, as shown in Fig. 13 first a 76 kHz signal is oscillated and when this passes the divider, a symmetrical 38 kHz signal is obtained.

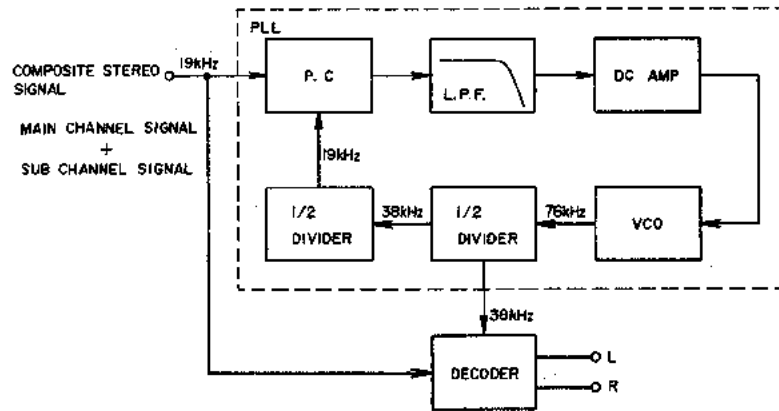

Fig. 15 MPX IC Function

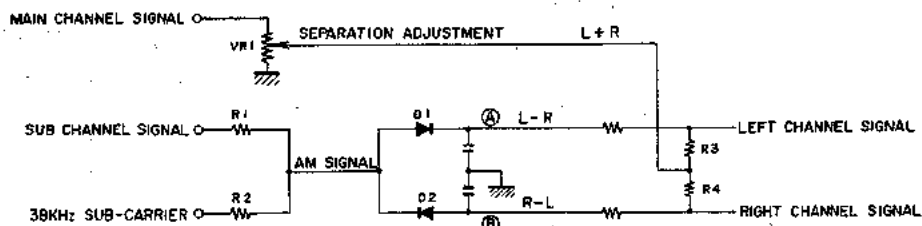

Fig. 16 Multiplex Decoder

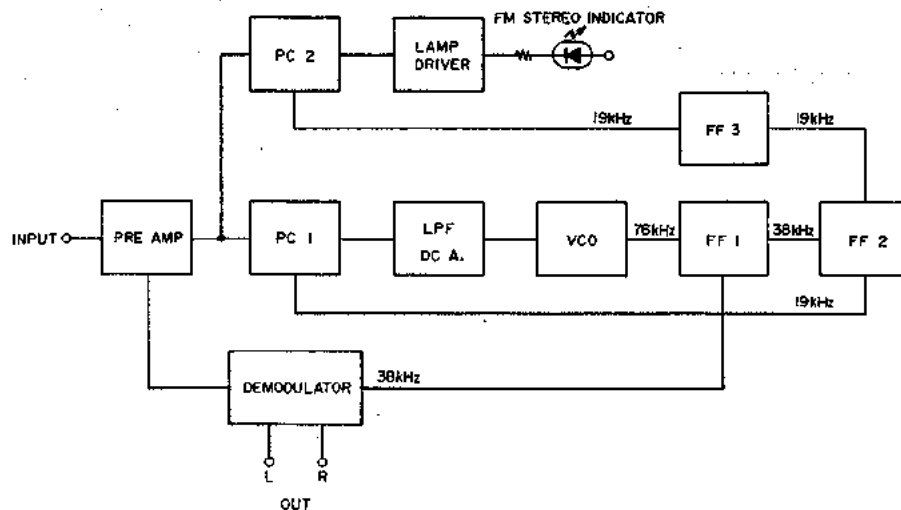

Fig. 17 LA-3350 Function System Diagram

This 38 kHz sub carrier is supplied to the multiplex decoder together with the sub channel of the composite stereo signal. At the multiplex decoder, left and right channel audio signals are separated in order as shown in Fig. 16.

The 38 kHz sub carrier composited with the sub channel signal of which the carrier part was removed when sub channel signal and sub carrier passed R1 R2 produces the regular AM wave. Then, because this envelop is detected by mutually reverse polarity connected diodes D1 and D2, L-R signal is emitted

at point A and R-L signal at point B.

Also, because main channel signal (L+R) is supplied to R3, R4 center point, A B point voltage is added and subtracted and becomes

$$(L+R) + (L-R) = 2L \text{ (left channel)}$$

$$(L+R) + (R-L) = 2R \text{ (right channel)}$$

The level of the main channel signal (L+R) can be adjusted by means of variable resistor VR(VR1) for optimum separation.

Thus, the function of actually employed PLL IC LA-3350 is a shown in Fig. 17.

VII. LEVEL DIAGRAM

1. MODEL AA-1115

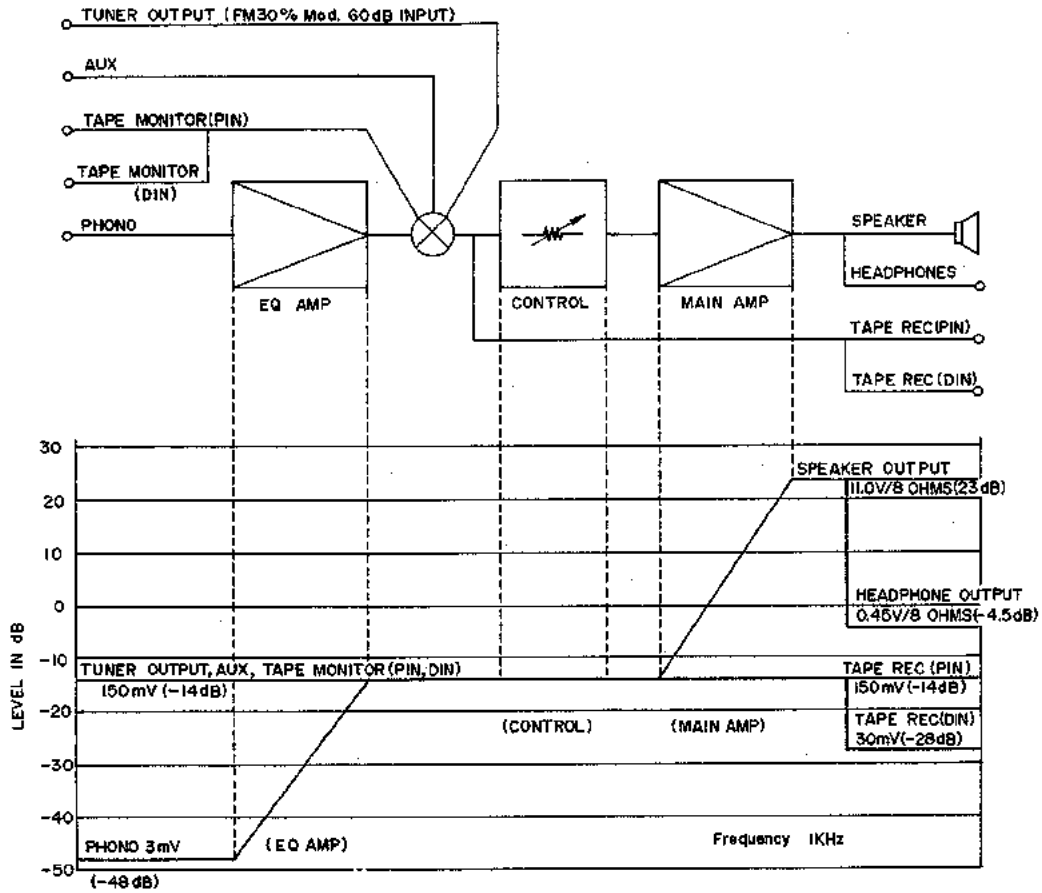

Fig. 18 Level Diagram

2. MODEL AA-1125

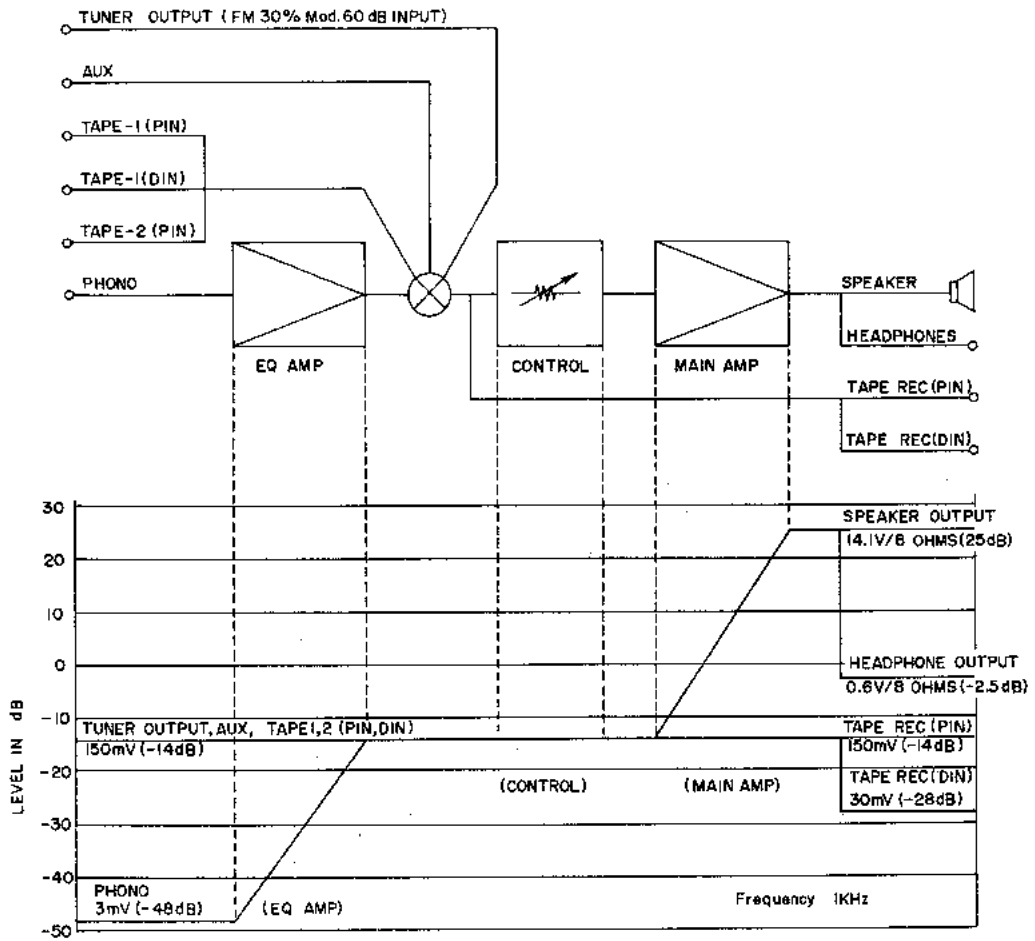

Fig. 19 Level Diagram

VIII. TUNER ADJUSTMENT

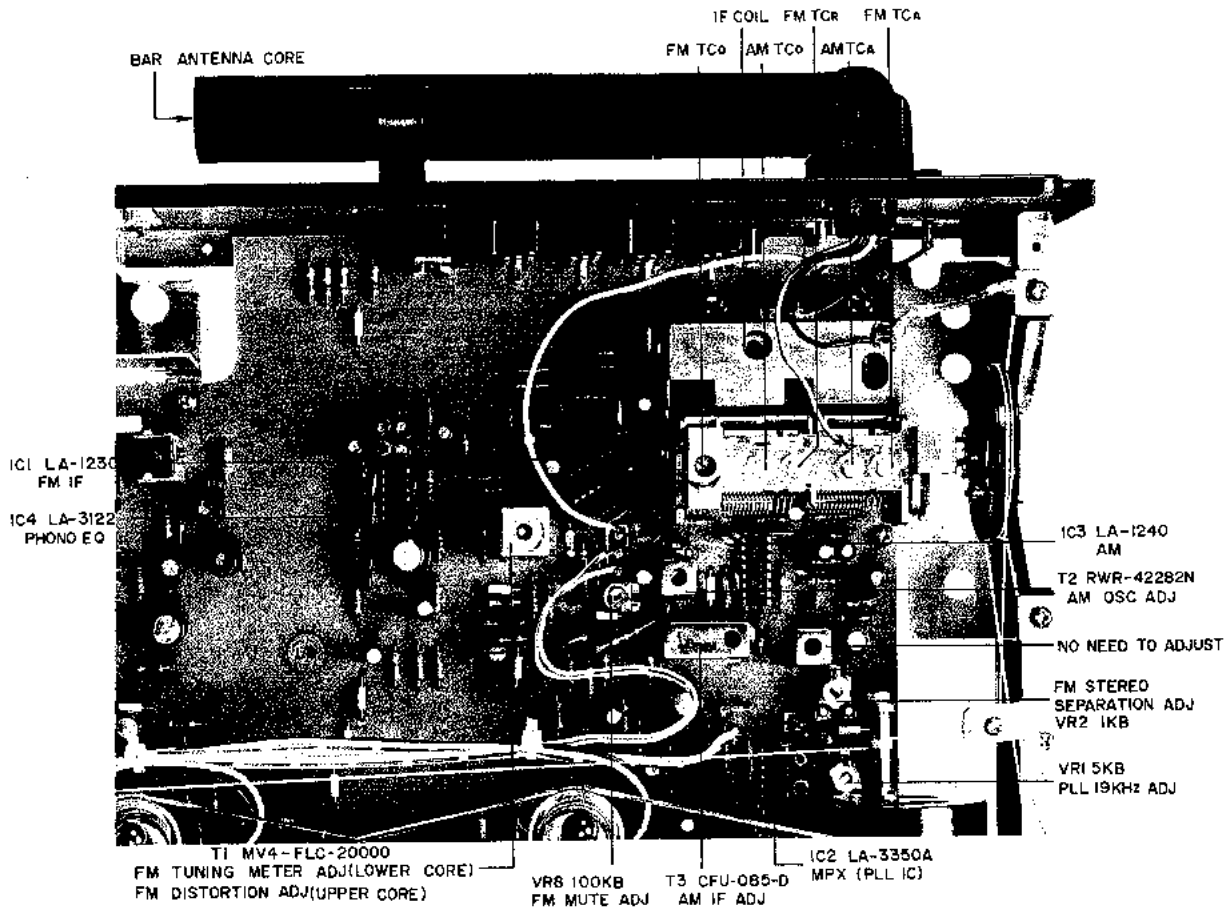

Fig. 20 Receiver P.C Board (AA-1115/AA-1125)

1. FM TUNER SECTION ADJUSTMENT (Refer to Fig. 20)

Step	Adjustment Item	Adjustment Point	Result	Remarks
1	Front End IF Coil	IF Coil (Front End)	Maximum Noise Level	SELECTOR to "FM". Tune in only Noise (without broadcasting interference).
2	Tuning Meter Centering	T1 Lower Side Core (Receiver P.C Board)	Center Tuning Meter Indication	Same as above
3	Distortion Factor	T1 Upper Side Core (Receiver P.C Board)	Less than 0.3% Distortion Factor	98 MHz, 60 dB (mono) input. Less than 0.3% on both channels.
4	Confirmation of Tuning Meter Indication			If Tuning Meter Indication is not at center position, re-adjust STEP 2 and 3 above.
5	Frequency Coverage	FM TCo (Front End)		108 MHz, 60 dB (mono) input error: within 300 kHz.
6	Sensitivity	FM TCA, TCR (Front End)	Less than 3% Distortion Factor	108 MHz, Less than 12 dB (mono) input.
7	Low Range Sensitivity Confirmation		Less than 3% Distortion Factor	88 MHz, Less than 12 dB (mono) input. See NOTE 1.
8	Mid Range Sensitivity Confirmation		Less than 3% Distortion Factor	98 MHz, Less than 12 dB (mono) input. See NOTE 1.
9	Mute Level	VR8 100 kB (Receiver P.C Board)	No signal emitted from output	MODE to "STEREO" 88 MHz, 20 dB (mono) input.
10	PLL IC Free Running Frequency	VR1 5 kB (Receiver P.C Board)	19.00 kHz	Frequency Counter to Test Point TP1 (Receiver P.C Board). See NOTE 2.
11	Stereo Indicator Lighting Confirmation			98 MHz, 60 dB (stereo) input. No lighting of stereo indicator indicates no stereo separation.
12	Stereo Separation	VR2 1 kB (Receiver P.C Board)	More than 40 dB (1 kHz)	98 MHz, 60 dB (stereo), L ch. input. Distortion Factor must be less than 0.6%.
13	Stereo Separation		More than 40 dB (1 kHz)	98 MHz, 60 dB (stereo), R ch. input. Distortion Factor must be less than 0.6%. If it exceeds 0.6% adjust the coil in STEP 1 within 1/2 turn.
14	Confirmation of Tuning Meter Indication		Center Tuning Meter Indication	

Chart 1

- NOTES: 1. When the distortion factor of less than 3% cannot be obtained at Step 7 and 8, repeat Front End IF Coil and Step 6 adjustments several times.
 2. Free Running Frequency of the PLL IC must be an exact 19.00 kHz.

2. AM TUNER SECTION ADJUSTMENT (Refer to Fig. 20)

Step	Adjustment Item	Adjustment Point	Result	Remarks
1	Low Range Scale Indication	T2 (RED) (Receiver P.C Board)	Maximum Output	Selector to AM. 520 kHz 50 dB input. Tuning Indicator to 520 kHz. Error within 2%.
2	Low Range Sensitivity	T3 (BLK and YLW) (Receiver P.C Board) Bar Antenna Core	Maximum Output Minimum Distortion Factor	520 kHz, 50 dB input. Tuning Indicator to 1,400 kHz. Error within 2%.
3	High Range Scale Indication	AM TCo (Front End)	Maximum Output	1,400 kHz, 50 dB input. Tuning Indicator to 1,400 kHz. Error within 2%.
4	High Range Sensitivity	AM TCA (Front End)	Maximum Output Minimum Distortion Factor	1,400 kHz, 50 dB input. Less than 10% Distortion Factor.

Chart 2

NOTE: For best results, repeat procedures Step 1 through 4 two or three times.

IX. MAIN AMPLIFIER ADJUSTMENT

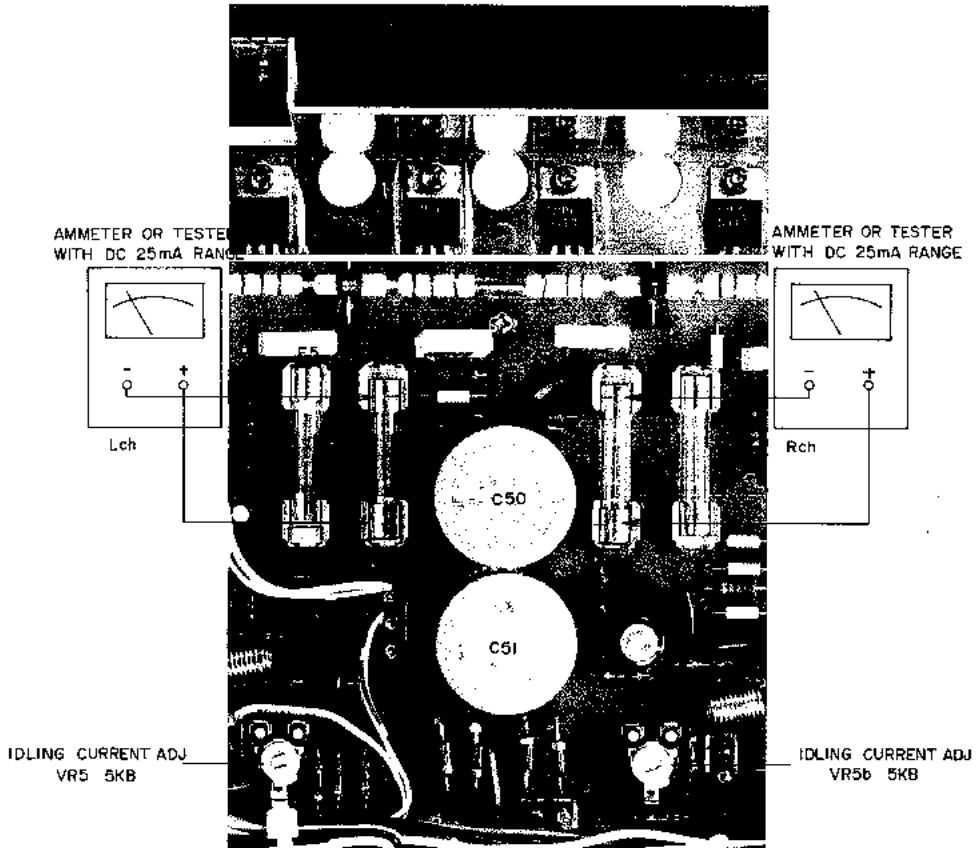

Fig. 21 Main Amplifier Adjustment (AA-1115)

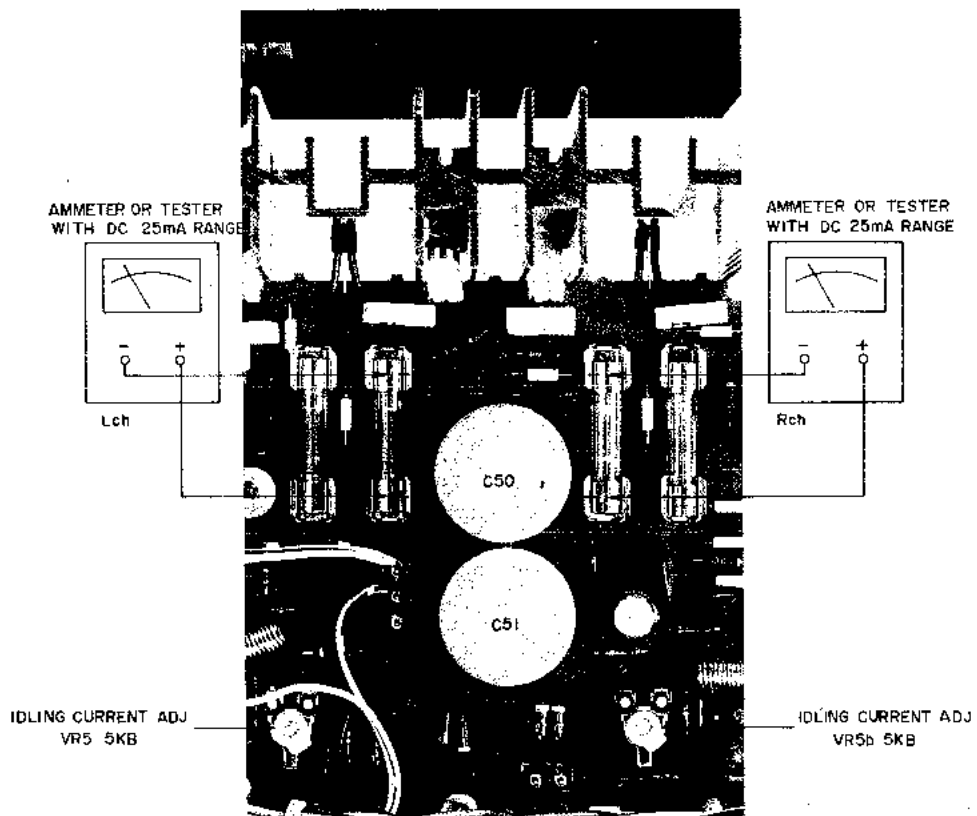

Fig. 22 Main Amplifier Adjustment (AA-1125)

(Refer to Figs. 21 and 22)

Step	Adjustment Item	Adjustment Point	Result	Remarks
1	Idling Current (L channel)	VR5 2 kB (Receiver P.C Board)	15 ± 5 mA	Disconnect fuses F4 and F5 prior to connecting an ammeter or tester.
2	Idling Current (R channel)	VR5b 2 kB (Receiver P.C Board)	15 ± 5 mA	

Chart 3

X. TUNING CORD THREADING

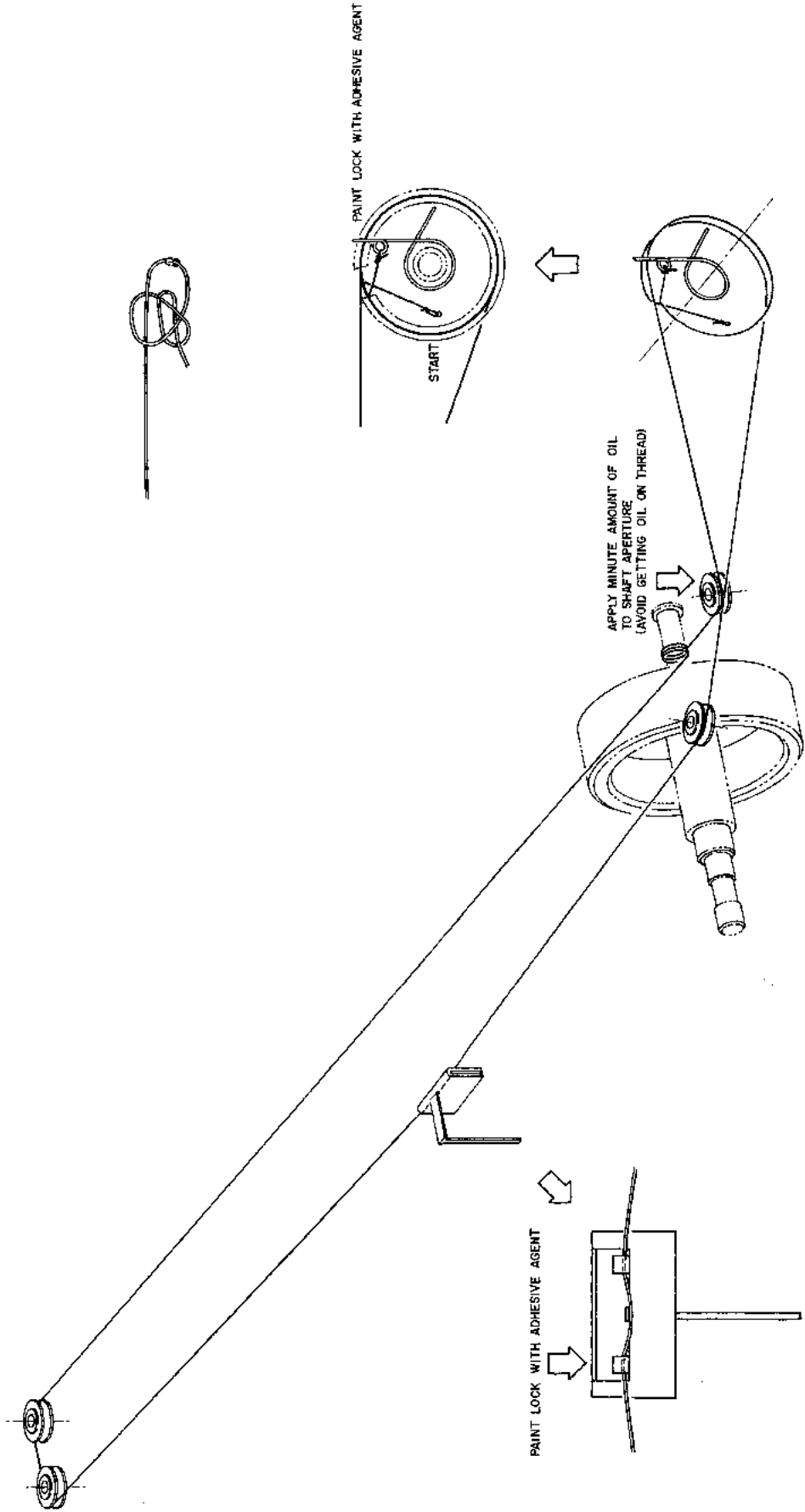

Fig. 23 Tuning Cord Threading

XI. CLASSIFICATION OF VARIOUS P.C BOARDS

1. RELATION OF P.C BOARD TITLE AND IDENTIFICATION NUMBER

1) MODEL AA-1115

P.C Board	P.C Board Number		
	U/T	CSA, AAL	CEE, BEAB
Receiver P.C Board	AB-1501A	AB-1501A	AB-1530A
Fuse P.C Board	AB-1501B	—	AB-1530B
Speaker Switch P.C Board	AB-1501C	AB-1501C	AB-1530C
LED P.C Board	AB-1501D	AB-1501D	AB-1530D
Coil P.C Board	—	AB-1501E	AB-1530E

Chart 4

2) MODEL AA-1125

P.C Board	P.C Board Number		
	U/T	CSA, AAL	CEE, BEAB
Receiver P.C Board	AB-2501A	AB-2501A	AB-2513A
Fuse P.C Board	AB-2501B	—	AB-2513B
Speaker Switch P.C Board	AB-2501C	AB-2501C	AB-2513C
LED P.C Board	AB-2501D	AB-2501D	AB-2513D
Coil P.C Board	—	AB-2501E	AB-2513E

Chart 5

2. COMPOSITION OF VARIOUS P.C BOARDS

1) MODEL AA-1115 P.C BOARD EXPLODED VIEW (U/T, CSA, AAL)

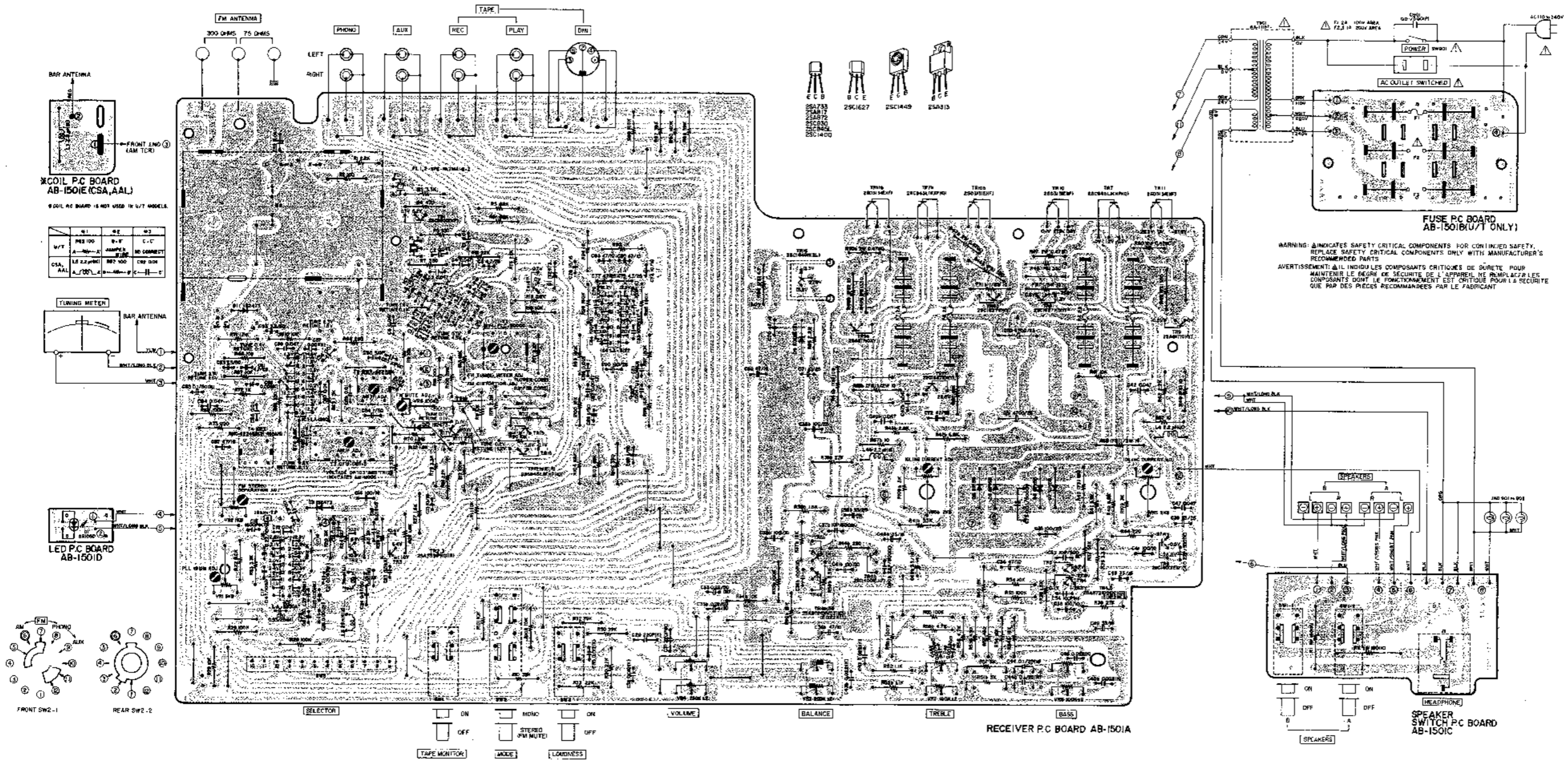

2) MODEL AA-1115 P.C BOARD EXPLODED VIEW (CEE, BEAB)

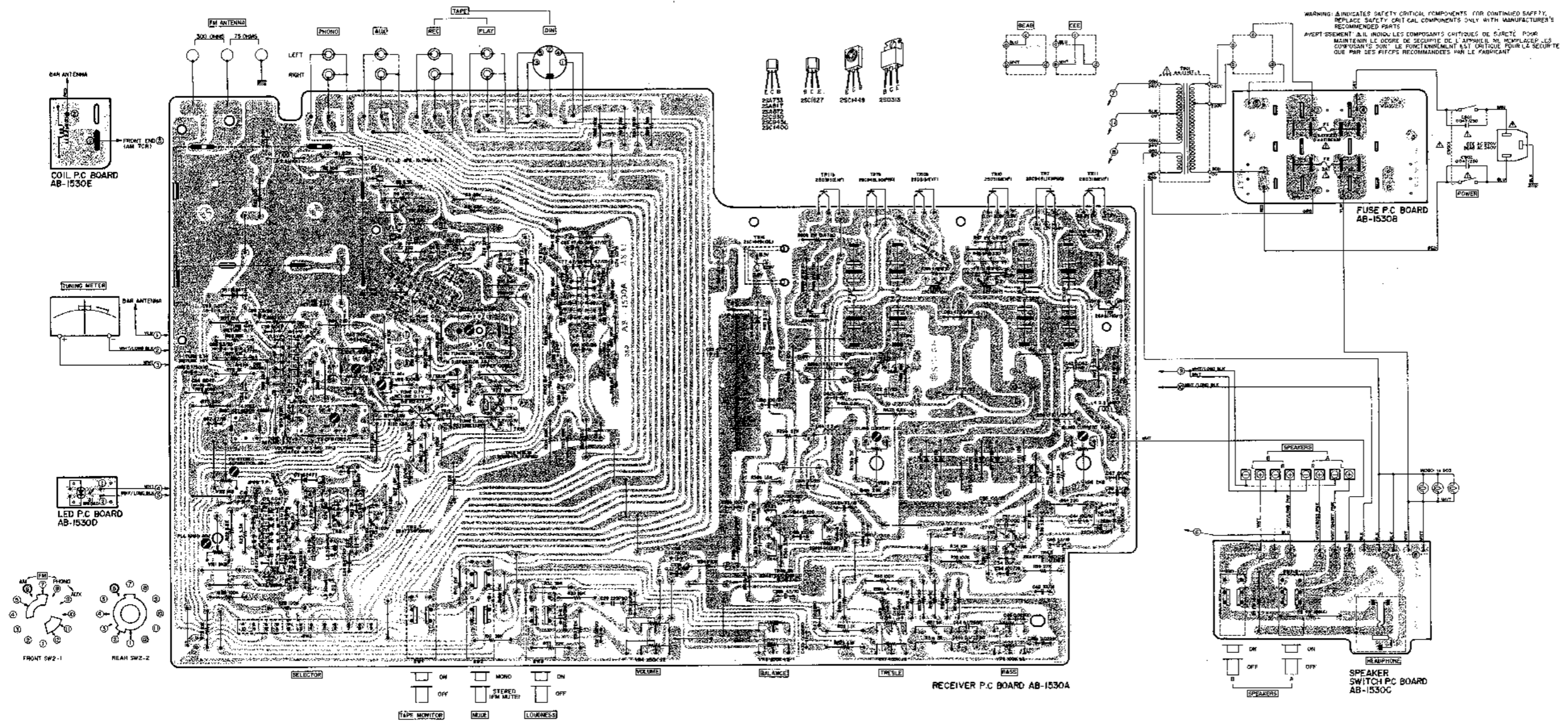

3) MODEL AA-1125 P.C BOARD EXPLODED VIEW (U/T, CSA, AAL)

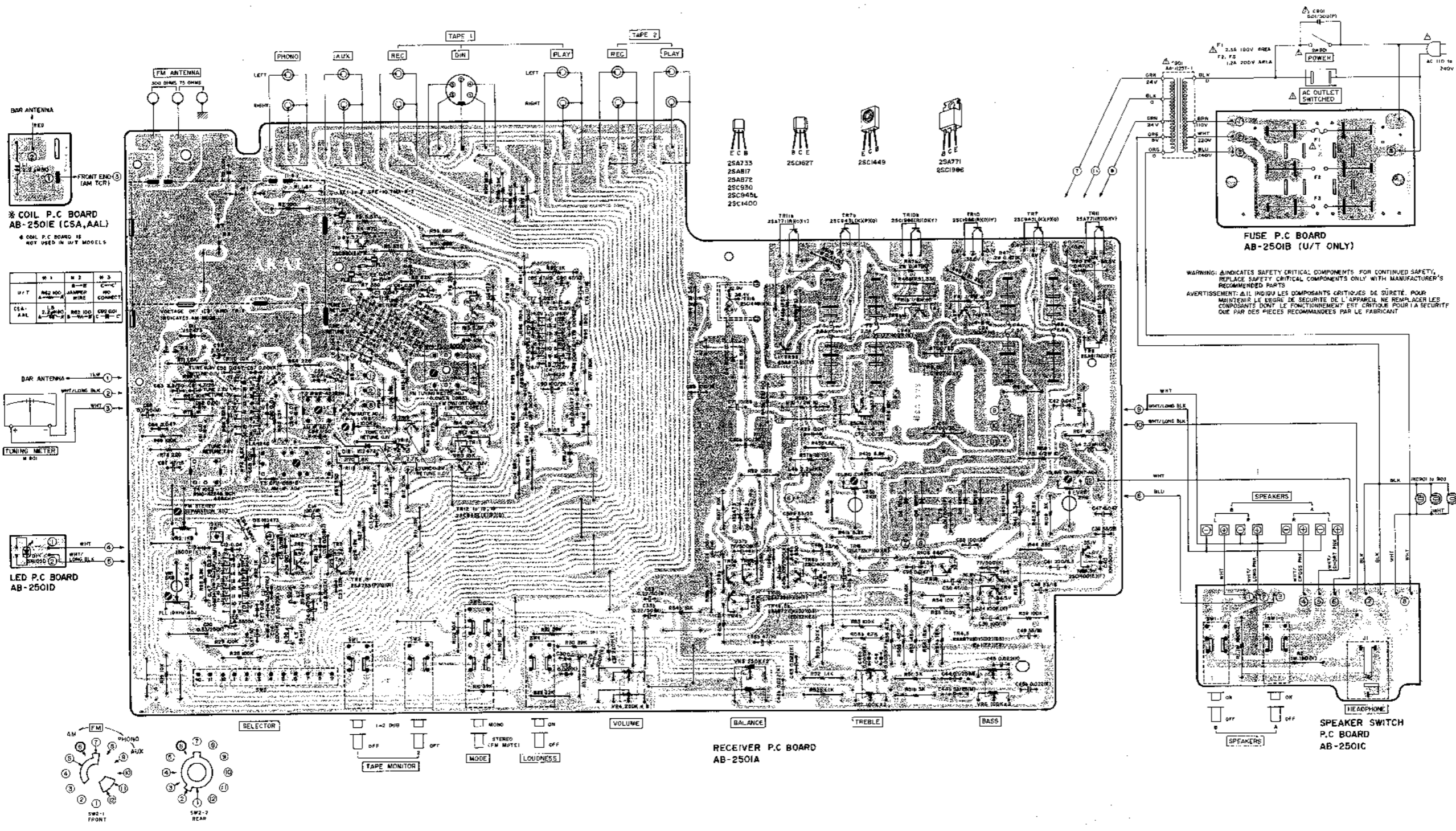

4) MODEL AA-1125 P.C BOARD EXPLODED VIEW (CEE, BEAB)

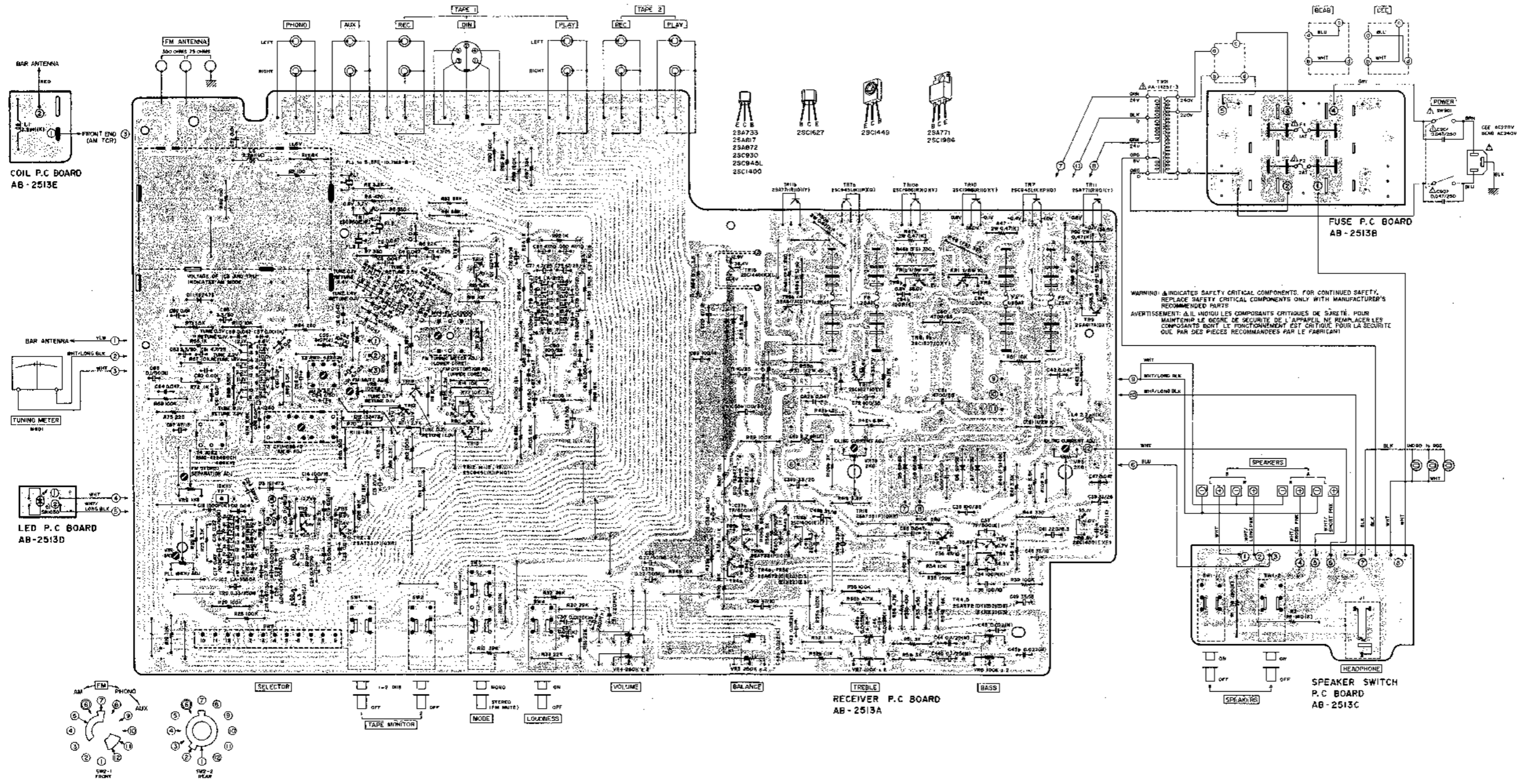

MEMO

SECTION 2

PARTS LIST

TABLE OF CONTENTS

1	RECOMMENDED SPARE PARTS LIST	32
2	RECEIVER P.C. BOARD (AB-1548) BLOCK	34
3	RECEIVER P.C. BOARD (AB-2525) BLOCK	35
4	AA-1115 ASSEMBLY BLOCK	36
5	AA-1125 ASSEMBLY BLOCK	38
6	AA-1115 FINAL ASSEMBLY BLOCK	40
7	AA-1125 FINAL ASSEMBLY BLOCK	41
8	LIST OF INTERCHANGEABLE SEMICONDUCTORS	42
	INDEX	43

Resistor and Capacitor which is not listed in this parts list, please refer to COMMON LIST FOR SERVICE PARTS.

HOW TO USE THIS PARTS LIST

1. This parts list is compiled by various individual blocks based on assembly process.
2. When ordering parts, please describe parts number, serial number, and model number in detail.
3. How to read List

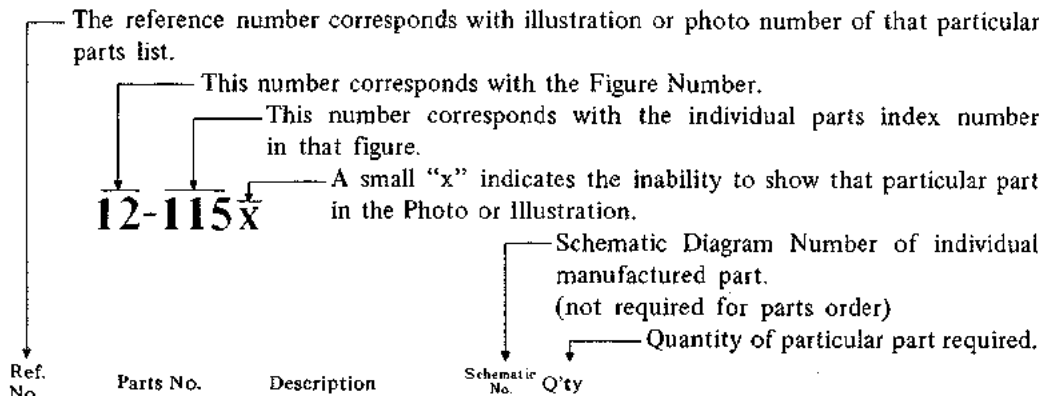

Ref. No.	Parts No.	Description	Schematic No.	Q'ty
FLYWHEEL BLOCK #13				
12-115x	800425	Flywheel Block Assy. Comp.	RDG #13	1
12-116	244506	Flywheel Only	RD-233	1
12-117x	244754	Felt, Flywheel	RD-275	1
12-118	251324	Main Metal Case	RD-236	1
12-119	253080	Main Metal	RD-237	1

4. The symbol numbers shown on the P.C. Board list can be matched with the Composite Views of Components of the Schematic Diagram or Service Manual.
5. Please utilize separate "Common List for Service Parts" for Resistor Parts orders.
6. The shape of the parts and parts name, etc. can be confirmed by comparing them with the parts shown on the Electrical Parts Table of P.C. Board.
7. Both the kind of part and installation position can be determined by the Parts Number. To determine where a parts number is listed, utilize Parts Index at end of Parts List.
It is necessary first of all to find the Parts Number. This can be accomplished by using the Reference Number listed at right of parts number in the Parts Index. (meaning of ref. no. outlined in Item 3 above).
8. Utilize separate "Price List for Parts" to determine unit price. The most simple method of finding parts Price is to utilize the reference number.

- CAUTION:**
1. When placing an order for parts, be sure to list the parts no., model no., and description. There are instances in which if any of this information is omitted, parts cannot be shipped or the wrong parts will be delivered.
 2. Please be careful not to make a mistake in the parts no. If the parts no. is in error, a part different from the one ordered may be delivered.
 3. Because parts number and parts unit supply in the Preliminary Service Manual (Basic Parts List) may be partially changed, please use this parts list for all future reference.

WARNING: ⚠ INDICATES SAFETY CRITICAL COMPONENTS. FOR CONTINUED SAFETY, REPLACE SAFETY CRITICAL COMPONENTS ONLY WITH MANUFACTURER'S RECOMMENDED PARTS.

AVERTISSEMENT: ⚠ IL INDIQU LES COMPOSANTS CRITIQUES DE SURETE. POUR MAINTENIR LE DEGRE DE SECURITE DE L'APPAREIL NE REMPLACER LES COMPOSANTS DONT LE FONCTIONNEMENT EST CRITIQUE POUR LA SECURITE QUE PAR DES PIECES RECOMMANDEES PAR LE FABRICANT.

AC INLET SYSTEM

This model is equipped with an AC INLET SYSTEM. Please refer to the AC INLET SYSTEM CHART below for the specific type. By the AC INLET SYSTEM, AC (mains) cord can be connected to and disconnected from the model because the model is provided with socket exclusively for AC (mains) cord on its main body. Please note, however, that certain models are not equipped with this system and has a built-in AC (mains) cord as before.

AC INLET SYSTEM CHART

CLASS I

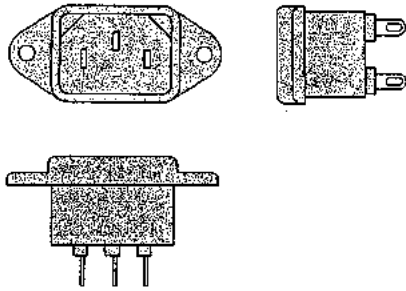

Picture 1
AC INLET
to be
installed
on machines

CLASS II

⊠ This mark indicating double insulation will be attached to machine's rear panel

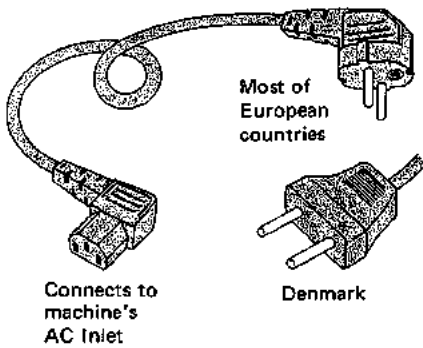
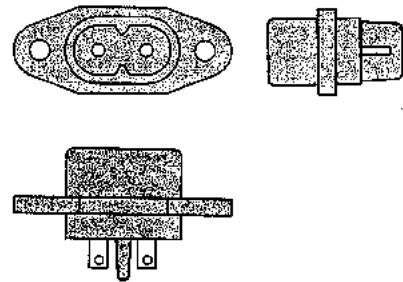

Picture 2
AC (mains)
cord

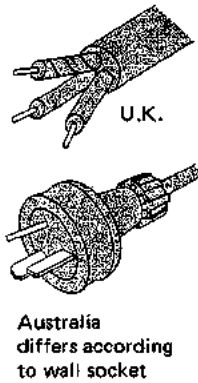
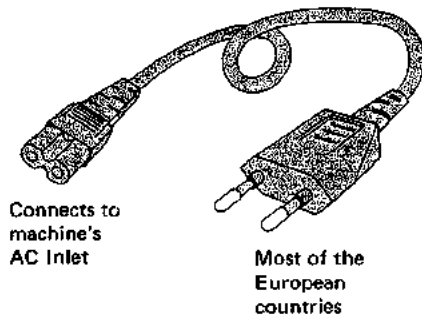

Parts List for AC (mains) Cord Set

	Standard	Description	Type of AC Inlet	Parts No.
Class I	CEE	Cord Set CEE (3 cores)	3P	EW302993
	BEAB	Cord Set BEAB (3 cores)	3P	EW302994
	SAA	Cord Set SAA (3 cores)	3P	EW302996
	U/T	Cord Set U/T (3 cores)	3P	EW302646
Class II	CEE	Cord Set CEE (2 cores)	2P	EW638144
	BEAB	Cord Set BEAB (2 cores)	2P	EW302995
	SAA	Cord Set SAA (2 cores)	2P	EW302991
	U/T	Cord Set U/T (2 cores)	2P	EW302899

1. RECOMMENDED SPARE PARTS LIST

Because, if the parts listed below are on hand, almost any repair can be accomplished, we suggest that you stock these Recommended Spare Parts Items.

Parts No.	Description	Note
BA297775	Receiver P.C Board Comp. AB-1501A	Only AA-1115 U/T
BA300143	Receiver P.C Board Comp. AB-1501A	Only AA-1115 CSA, AAL
BA297786	Receiver P.C Board Comp. AB-1530A	Only AA-1115 CEE, BEAB
BA287087	Speaker SW. P.C Board Comp. AB-1501C	Only AA-1115 U/T, CSA, AAL
BA287076	Speaker SW. P.C Board Comp. AB-1530C	Only AA-1115 CEE, BEAB
BA300496	Coil P.C Board Comp. AB-1501E	Only AA-1115 CSA, AAL
BA300497	Coil P.C Board Comp. AB-1530E	Only AA-1115 CEE, BEAB
BA297797	Receiver P.C Board Comp. AB-2501A	Only AA-1125 U/T
BA300144	Receiver P.C Board Comp. AB-2501A	Only AA-1125 CSA, AAL
BA297808	Receiver P.C Board Comp. AB-2513A	Only AA-1125 CEE, BEAB
BA287065	Speaker SW. P.C Board Comp. AB-2501C	Only AA-1125 U/T, CSA, AAL
BA291036	Speaker SW. P.C Board Comp. AB-2513C	Only AA-1125 CEE, BEAB
BA300139	Coil P.C Board Comp. AB-2501E	Only AA-1125 CSA, AAL
BA300140	Coil P.C Board Comp. AB-2513E	Only AA-1125 CEE, BEAB
BC298890	Cabinet AB-1525	
BD300013	Front Panel Block Comp. AA-1115	Only AA-1115
BD300015	Front Panel Block Comp. AA-1125	Only AA-1125
BT293670	△ Power Transformer AA-1115T-1	Only AA-1115 U/T
BT296730	△ Power Transformer AA-1115T-2	Only AA-1115 CSA
BT296785	△ Power Transformer AA-1115T-3	Only AA-1115 CEE, BEAB
BT296763	△ Power Transformer AA-1115T-4	Only AA-1115 AAL
BT293681	△ Power Transformer AA-1125T-1	Only AA-1125 U/T
BT296752	△ Power Transformer AA-1125T-2	Only AA-1125 CSA
BT295762	△ Power Transformer AA-1125T-3	Only AA-1125 CEE, BEAB
BT296774	△ Power Transformer AA-1125T-4	Only AA-1125 AAL
BT697950	AM IF Transformer CFU-085-D	
BT293398	AM IF Transformer 10EZ RMC-42246BCH46	
EC650430	Ceramic Filter SFE-10.7MA-8-Z	
ED293523	Luminous Diode SR105D	
ED219903	Silicon Diode GP15D	
ED223558	Zener Diode RD13E(B)	Only AA-1115
ED300829	Zener Diode RD13E(C)	Only AA-1125
ED215100	Front End FB512U18	
EE293657	Bar Antenna	
EI650586	IC LA-1230	
EI293185	IC LA-1240	
EI697871	IC LA-3122	
EI293207	IC LA-3350A	
EJ240581	4P Push Terminal	

Parts No.	Description	Note
EL267208	Lamp (Cord Type) 8V 300 mA (400mm×2)	
EM655727	Tuning Meter KL-218D-94	
EO539820	Peaking Coil 2.2μH (K)	
EO650823	Phase Compensation Coil 2.2μH (K)	
EO650608	Discriminator Coil MV4-FLC-20000	
EO293387	AM Oscillator Coil RWR-42282N	
ER293635	Fuseable Resistor FRN 158 1/4W 10 ohms(J) 700 mA	
ES293308	Push Switch (3 throw)	Only AA-1115
ES293310	Push Switch (4 throw)	Only AA-1125
ES293501	Push Switch (2 throw)	SW2 Speaker Selector
ES239218	△ Push Switch JP01 (TV-4)	SW901 Only AAL
ES224436	△ Push Switch JP01	SW901 Only U/T, CSA
ES242346	△ Push Switch JP17	SW901 Only CEE, BEAB
ES293275	Rotary Switch	SW2
ET293545	Transistor 2SA711 (R) (O) (Y)	
ET293220	Transistor 2SA817 (O) (Y)	
ET293218	Transistor 2SA872 (D1) (D2) (D3) (E1) (E2) (E3)	
ET618873	Transistor 2SC930 (E) (F)	
ET293264	Transistor 2SC1400 (E) (F)	
ET649034	Transistor 2SC1449 (K) (L)	
ET293253	Transistor 2SC1627 (O) (Y)	
ET293534	Transistor 2SC1986 (R) (O) (Y)	
EV224954	Single axial 2 throw Vol. V16L4G1Z 250k×2	VR3
EV293354	Single axial 2 throw Vol. V16LG15C 100k×2	VR6
EV293343	Single axial 2 throw Vol. V16LG3B 250kB×2	VR4
SK286367	Push Button Knob (A) AC-3537	
SK223705	Tuning Knob T2-5019	Same as AT-2200/L
SK646817	Single Knob AA-5250	Same as AT-2200/L
TA298980	Scale Plate AB-1513/AB-1514	

2. RECEIVER P.C BOARD (AB-1548) BLOCK

Symbol No.	Parts No.	Description	Schematic No.	Q'ty	Symbol No.	Parts No.	Description	Schematic No.	Q'ty
2-1	BA297775	Receiver P.C Board Comp. AA-1115(U/T)	AB-1548	1	2-FL1,2	ER650430	Ceramic Filter SFE-10.7 MA-8-Z	53-1-102	2
2-2	BA300143	Receiver P.C Board Comp. AA-1115(CSA)	AB-1548	1	2-L1	EO650610	Inductor 144LZ 18μH(J)	23-1-240	1
2-3	BA301507	Receiver P.C Board Comp. AA-1115(AAL)	AB-1548	1	2-L2,3	EO697915	Inductor RCP-095 39MH(J)	23-1-245	1
2-4	BA297786	Receiver P.C Board Comp. AA-1115(CEE)	AB-1548	1	2-L4	EO250143	Coil, Phase Equalizer 2.2μF(K)	23-1-260	2
2-IC1	EI650586	IC LA-1230	45-8-152	1	2-L5	EO539820	Peaking Coil 2.2μH(K) (CSA,CEE)	23-1-187	1
2-IC2	EI293207	IC LA-3350A	45-8-153	1	2-R47	ER552712	Metal Plate/R. MPC70F 2W		
2-IC3	EI293185	IC LA-1240	45-8-220	1	2-R50	ER552712	Metal Plate/R. MPC70F 2W		
2-IC4	EI697871	IC LA-3122	45-8-185	1	2-R50	ER552712	Metal Plate/R. MPC70F 2W		
2-TR1	ET618873	Transistor 2SC930(E)(F)	45-1-185	1	2-FR1	ER293635	Fuse/R. FRN158 1/4W 10 ohms(J) 700MA	35-14-20	2
2-TR2,3	ET539122	Transistor 2SA733(P)(Q)(R)	45-1-124	2	2-C16	EC559181	Solid Aluminum/C. (Vert. Type) 0.22μF(M) 10WV	24-19-2	1
2-TR4,5	ET293218	Transistor 2SA872(D1)(D2)(D3) (E1)(E2)(E3)	45-1-260	4	2-C17	EC538244	Solid Aluminum/C. (Vert. Type) 0.47μF(M) 10WV	24-19-2	1
2-TR6	ET293264	Transistor 2SC1400(E)(F)	45-1-261	2	2-C18	EC666494	Styrol/C. (Vert. Type) 1500PF(K) 50WV	24-11-3	1
2-TR7	ET632204	Transistor 2SC945L(K)(P)(Q)	45-1-85	2	2-C20	EC293602	Solid Aluminum/C. (Vert. Type) 0.33μF(M) 10WV	24-19-2	1
2-TR8	ET293253	Transistor 2SC1627(O)(Y)	45-1-263	2	2-C50,51	EC293400	Elect./C. 4700μF 25WV	24-10-117	2
2-TR9	ET293220	Transistor 2SA817(O)(Y)	45-1-262	2	2-C55	EC650406	Styrol/C. (Vert. Type) 310PF(J) 50WV	24-11-3	1
2-TR12to15	ET632204	Transistor 2SC945L(K)(P)(Q)	45-1-85	4	2-C73	EC684720	Ceramic/C. CLD16YE 0.01μF(P) 500WV	24-5-61	1
2-TR16	ET649034	Transistor 2SC1449(K)(L)	45-1-214	1	2-5	ZS325495	Tapping Screw #2, 3x6(BR)		1
2-TR17	ET293253	Transistor 2SC1627(O)(Y)	45-1-263	1	2-6	EE655301	Front End FB512U13	57-2-35	1
2-TR19	ET632204	Transistor 2SC945L(K)(P)(Q)	45-1-85	1	2-7	EE301419	Front End FB513U12 (CEE)	57-2-44	1
2-D1	ED624903	Silicon Diode 1S2473	45-3-28	1	2-8	EJ514822	Fuse Holder, P.C Board S-N5051 (U/T, CSA)	40-1-28	8
2-D3	ED624903	Silicon Diode 1S2473	45-3-28	1	2-9	EJ592503	Fuse Clip, P.C Board HO426(CEE)	40-1-37	8
2-D4	ED300829	Zener Diode RD-13E(C)	45-6-72	1					
2-D5to8	ED219903	Silicon Diode GP15D	45-2-71	4					
2-D11	ED300946	Silicon Diode 1S2473HC	45-3-42	1					
2-D12	ED624903	Silicon Diode 1S2473	45-3-28	1					
2-SW1,2,3	ES293308	Push SW. (3 throw) J-P7142	25-5-252	1					
2-SW5	ES293275	Rotary SW. SR26(PH-2)N 1-3-4	25-6-109	1					
2-J1	EJ698051	Din Jack	31-1-158	1					
2-J2	EJ293365	4P Pin Jack	31-1-197	2					
2-VR1	EV499364	Semi-fixed/Vol. V10K8-4-2 5 kΩ	36-10-250	1					
2-VR2	EV484863	Semi-fixed/Vol. V10K8-4-2 1 kΩ	36-10-250	1					
2-VR3	EV224954	Single axial 2 throw Vol. V16L4G1Z							
		250kx2	36-22-17	1					
2-VR4	EV293343	Single axial 2 throw Vol. V16LG3B							
		250kx2	36-22-26	1					
2-VR5	EV269572	Semi-fixed/Vol. V10K8-4-2 2 kΩ	36-10-250	2					
2-VR6,7	EV293354	Single axial 2 throw Vol. V16LG15C							
		100kx2	36-22-27	2					
2-VR8	EV464231	Semi-fixed/Vol. V8K4-1 100 kΩ	36-18-266	1					
2-T1	EO650608	Discri Coil MV4-FLC-20000	23-1-243	1					
2-T2	EO293387	OSC Coil RWR-42282N	23-4-41	1					
2-T3	BT697950	AM-IF Trans. CFU-085-D	23-1-241	1					
2-T4	BT293398	AM-IF Trans. 10EZ RMC-42246BCH 46	23-1-276	1					

When ordering parts, Please describe Parts Number, Description, and Model Number in detail.

3. RECEIVER P.C BOARD (AB-2525) BLOCK

Symbol No.	Parts No.	Description	Schematic No.	Q'ty	Symbol No.	Parts No.	Description	Schematic No.	Q'ty
3-1	BA297797	Receiver P.C Board			3-T4	BT293398	AM-IF Trans. 10EZ		
		Comp. AA-1125(U/T)	AB-2525	1			RMC-42246BCH 46	23-1-280	1
3-2	BA300144	Receiver P.C Board			3-EL1 to3	ER650430	Ceramic Filter		
		Comp. AA-1125(CSA)	AB-2525	1			SFE-10.7 MA-8-Z	53-1-102	3
3-3	BA301508	Receiver P.C Board			3-L1	EO650610	Inductor 144LZ		
		Comp. AA-1125(AAL)	AB-2525	1			18μH(J)	23-1-240	1
3-4	BA297808	Receiver P.C Board			3-L2,3	EO697915	Inductor RCP-095		
		Comp. AA-1125(CEE)	AB-2525	1			39MH(J)	23-1-245	1
3-IC1	EI650586	IC LA-1230	45-8-152	1	3-L4	EO250143	Coil, Phase Equalizer		
3-IC2	EI293207	IC LA-3350A	45-8-153	1			2.2μF(K)	23-1-260	2
3-IC3	EI293185	IC LA-1240	45-8-220	1	3-L5	EO539820	Peaking Coil		
3-IC4	EI697871	IC LA-3122	45-8-185	1			2.2μH(K) (CSA,CEE)	23-1-187	1
3-TR1	ET618873	Transistor			3-R47	ER552712	Metal Plate/R,		
		2SC930(E)(F)	45-1-185	1			MPC70F 2W		
3-TR2,3	ET539122	Transistor					0.47 ohm(K)	35-16-38	2
		2SA733(P)(Q)(R)	45-1-124	2	3-R50	ER552712	Metal Plate/R,		
3-TR4,5	ET293218	Transistor					MPC70F 2W		
		2SA872(D1)(D2)(D3)	45-1-260	4			0.47 ohm(K)	35-16-38	2
		(E1)(E2)(E3)			3-FR1	ER293635	Fuse/R. FRN1 58		
3-TR6	ET293264	Transistor					1/4W 10 ohms(J)		
		2SC1400(E)(F)	45-1-261	2			700MA	35-14-20	2
3-TR7	ET632204	Transistor			3-C16	EC559181	Solid Aluminum/C.		
		2SC945L(K)(P)(Q)	45-1-85	2			(Vert. Type)		
3-TR8	ET293253	Transistor					0.22μF(M) 10WV	24-19-2	1
		2SC1627(O)(Y)	45-1-263	2	3-C17	EC538244	Solid Aluminum/C.		
3-TR9	ET293220	Transistor					(Vert. Type)		
		2SA817(O)(Y)	45-1-262	2			0.47μF(M) 10WV	24-19-2	1
3-TR12to15	ET632204	Transistor			3-C18	EC666494	Styrol/C. (Vert. Type)		
		2SC945L(K)(P)(Q)	45-1-85	4			1500PF(K) 50WV	24-11-3	1
3-TR16	ET649034	Transistor			3-C20	EC293602	Solid Aluminum/C.		
		2SC1449(K)(L)	45-1-214	1			(Vert. Type)		
3-TR17	ET293253	Transistor					0.33μF(M) 10WV	24-19-2	1
		2SC1627(O)(Y)	45-1-263	1	3-C50,51	EC300742	Elect./C. (Vert. Type)		
3-TR18	ET539122	Transistor					4700μF 35WV	24-10-116	2
		2SA733(P)(Q)(R)	45-1-124	2	3-C55	EC650406	Styrol/C. (Vert. Type)		
3-TR19	ET632204	Transistor					310PF(J) 50WV	24-11-3	1
		2SC945L(K)(P)(Q)	45-1-85	1	3-C73	EC684720	Ceramic/C. CLD16YE		
3-D1	ED624903	Silicon Diode 1S2473	45-3-28	1			0.01μF(P) 500WV	24-5-61	1
3-D3	ED624903	Silicon Diode 1S2473	45-3-28	1	3-5	ZS325495	Tapping Screw #2,		
3-D4	ED300829	Zener Diode					3x6 (BR)		
		RD-13E(C)	45-6-72	1	3-6	EE655301	Front End FB512U13		
3-D5to8	ED219903	Silicon Diode GP15D	45-2-71	4	3-7	EE301419	Front End FB513U12		
3-D9,10	ED624903	Silicon Diode 1S2473	45-3-28	2			(CEE)	57-2-44	1
3-D11	ED300946	Silicon Diode			3-8	EJ514822	Fuse Holder,		
		1S2473HC	45-3-42	1			P.C Board S-N5051		
3-D12	ED624903	Silicon Diode 1S2473	45-3-28	1			(U/T, CSA)	40-1-28	8
3-SW1to4	ES293310	Push SW. (4 throw)			3-9	EJ592503	Fuse Clip, P.C Board		
		J-P7143	25-5-253	1			HO426 (CEE)	40-1-37	8
3-SW5	ES293275	Rotary SW.							
		SR26(PH-2)N 1-3-4	25-6-108	1					
3-J1	EJ698051	Din Jack							
		31-1-158	31-1-158	1					
3-J2	EJ293376	6P Pin Jack							
		31-1-198	31-1-198	2					
3-VR1	EV499364	Semi-fixed/Vol.							
		V10K8-4-2 5 kΩ	36-10-250	1					
3-VR2	EV484863	Semi-fixed/Vol.							
		V10K8-4-2 1 kΩ	36-10-250	1					
3-VR3	EV224954	Single axial 2 throw							
		Vol. V16L4G1Z							
		250kx2	36-22-17	1					
3-VR4	EV293343	Single axial 2 throw							
		Vol. V16LG3B							
		250kx2	36-22-26	1					
3-VR5	EV269572	Semi-fixed/Vol.							
		V10K8-4-2 2 kΩ	36-10-250	2					
3-VR6,7	EV293354	Single axial 2 throw							
		Vol. V16LG15C							
		100kx2	36-22-27	2					
3-VR8	EV464231	Semi-fixed/Vol.							
		V8K4-1 100 kΩ	36-10-266	1					
3-T1	EO650608	Discri Coil							
		MV4-FLC-20000	23-1-243	1					
3-T2	EO293387	OSC Coil							
		RWR-42282N	23-4-41	1					
3-T3	BT697950	AM-IF Trans.							
		CFU-085-D	23-1-241	1					

When ordering parts, Please describe Parts Number, Description, and Model Number in detail.

4. ILLUSTRATION OF AA-1115 ASSEMBLY BLOCK

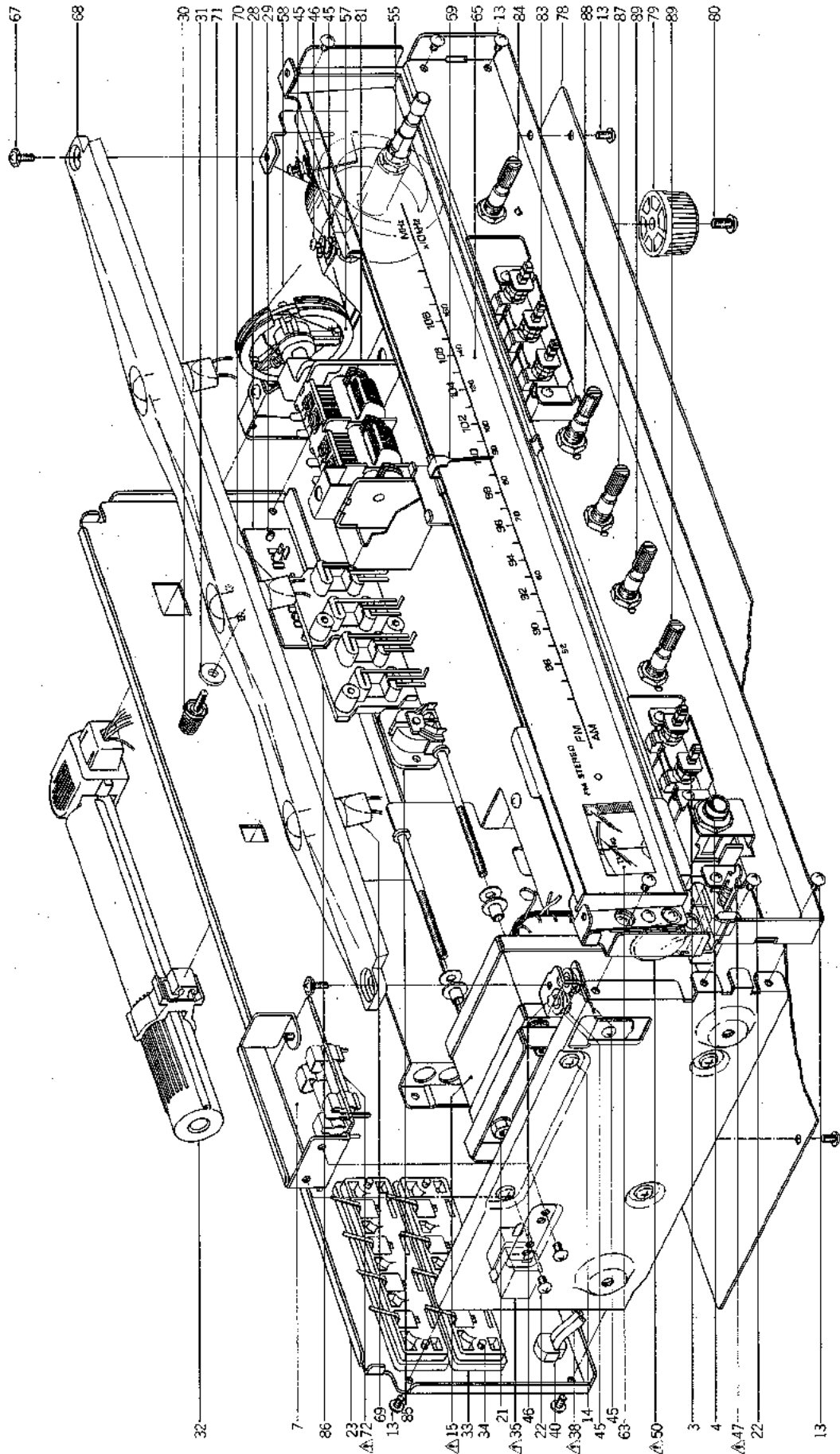

4) AA-1115 ASSEMBLY BLOCK

Ref. No.	Parts No.	Description	Schematic No.	Q'ty
SPEAKER SW. P.C BOARD BLOCK				
4-1x	BA287087	Speaker SW. P.C Board Comp. (U/T)	AB-1546	1
4-2x	BA287076	Speaker SW. P.C Board Comp. (CEE)	AB-1546	1
4-3	ES293501	Push SW. (2 throw) J-P7111	25-5-251	1
4-4	EJ225022	Headphone Jack LJ255-1-12	31-2-77	1
4-5x	ER511288	Metal Oxide Film/R. 1W 180 ohms(K)	35-15-10	2
LED P.C BOARD BLOCK				
4-6x	EO698826	LED SR-105D	45-15-16	1
FUSE P.C BOARD BLOCK				
4-7	BA300153	Fuse P.C Board 101 Comp. (U/T)	AB-1547	1
4-8x	BA300154	Fuse P.C Board 101 Comp. (CEE) (BEAB)	AB-1547	1
COIL P.C BOARD BLOCK				
4-9x	EO539820	Peaking Coil 2.2μH(K)	23-1-187	1
HEAT-SINK BLOCK				
4-10x	ET452531	Transistor 2SD313(E)(F)	45-1-105	4
4-11x	ZW632226	Insulator Washer Bush M	45-16-27	4
4-12x	ZS379350	Screw, pan head 3x6		4
SIDE PLATE (L) BLOCK				
4-13	ZS325495	Tapping Screw #2, 3x6(BR)		23
4-14	ZS416687	Screw, binding head 4x8		4
4-15	BT293670	△ Power Trans. AA-1115T-1 (U/T)	38-4-492	1
4-16x	BT296730	△ Power Trans. AA-1115T-2 (CSA)	38-4-493	1
4-17x	BT296763	△ Power Trans. AA-1115T-4 (AAL)	38-4-495	1
4-18x	BT296785	△ Power Trans. AA-1115T-3 (CEE, BEAB)	38-4-494	1
4-19x	ZW237857	Washer D4, 1x10x1t		4
4-20x	ZW273914	Spring Washer		4
4-21	ZW413188	Nut M4, #1		4
4-22	ZS417216	Screw, pan head 3x4		8
REAR PANEL BLOCK				
4-23	SP298732	Rear Panel (1) (U/T)	AB-1522	1
4-24x	SP298721	Rear Panel (2) (CSA)	AB-1522	1
4-25x	SP298765	Rear Panel (3) (AAL)	AB-1522	1
4-26x	SP298754	Rear Panel (4) (CEE)	AB-1523	1
4-27x	SP298743	Rear Panel (5) (BEAB)	AB-1524	1
4-28	EJ293646	3P Antenna Terminal Plate	32-1-78	1
4-29	ZW698308	Nylon Rivet (FNPR) 3x5.5(Black)	2-7-54	2
4-30	SK652397	Knob 0512-2	34-1-4	1
4-31	ZW651082	Washer (SPC) D3.2x10x1t		1
4-32	EE293657	Bar Antenna	55-1-51	1
4-33	EJ240581	4P Push Terminal	32-1-72	2
4-34	ZS522865	Tapping Screw #2, 3x12(BR)		4
4-35	EJ293668	AC Consent S-16432 (U/T, CSA, AAL)	31-1-147	1
4-36x	EJ296853	3P In-Let CM-3(CEE, BEAB)	31-1-199	1
4-37x	ZS463353	Tapping Screw #2, 3x8 (BR) (CEE, BEAB)		1
4-38	EW374894	AC Cord CUL 3M (U/T)	26-3-19	1
4-39x	EW207742	AC Cord CUL (CSA, AAL)	26-3-45	1
4-40	E2631945	Strain Relief SR-4N-4 (U/T, CSA, AAL)	2-7-49	1
4-41x	ZW273767	Earth Lug D3x20L (CSA, AAL, CEE, BEAB)		1
4-42x	ZS421740	Screw, pan head 3x8 (CSA, AAL, CEE, BEAB)		2
4-43x	ZW273802	Toothed Lock Washer (CSA, AAL, CEE, BEAB)		2
4-44x	ZW273756	Nut M3, #1 (CSA, AAL, CEE, BEAB)		2

Ref. No.	Parts No.	Description	Schematic No.	Q'ty
ASSEMBLY BLOCK				
4-45	MR530662	Roller B	91-5009	2
4-46	ZS530673	Roller Screw A	91-5010	2
4-47	ES224436	△ Push SW. JP01 (U/T, CSA)	25-5-221	1
4-48x	ES239218	△ Push SW. JP01 (TV-4) (AAL)	25-5-222	1
4-49x	ES242346	△ Push Sw. JP17 (CEE)	25-5-224	1
4-50	EC204671	△ Ceramic/C. DD31-6 0.01μF(P) 500WV(U/T)	24-5-66	1
4-51x	EC286198	△ Ceramic/C. AL-10 0.01μF(Z) 125WV (CSA, AAL)	24-5-69	1
4-52x	EC301320	△ MP/C. PME271Y447 4700PF 250WV (CEE)	24-9-118	2
4-53x	ZW273767	Earth Lug D3x20L		1
4-54x	ZS447840	Tapping Screw #2, 3x8(BR)		1
4-55	MF293714	Tuning Wheel	13-2-27	1
4-56x	ZS447761	Tapping Screw #2, 3x6(BR) (Black)		8
4-57	MI650136	Dial Wheel D45 N01008	2-15-11	1
4-58	TA207347	Thread D0.5 1600mm		1
4-59	TA299092	Pointer Part (U/T)	AB-1527	1
4-60x	TA302724	Pointer BL Part (BL-U/T)	AB-1527	1
4-61x	TA299070	Pointer UL Part (AAL)	AB-1527	1
4-62x	TA302802	Pointer UL BL Part(BL-AAL)	AB-1527	1
4-63	EM655727	Tuning Meter KL-218D-94	46-1-110	1
4-64x	EM288448	Tuning Meter KL-218D-103 (BL)	46-1-154	1
4-65	TA298980	Scale Plate	AB-1513/ AB-1514	1
4-66x	TA302725	Scale Plate BL	AB-1513/ AB-1514	1
4-67	ZS498273	Tapping Screw #2, 3x8 w/washer		4
4-68	TA298934	Illumination Plate	AB-1515	1
4-69	EL267197	Lamp (Cord Type) 8V 300 mA (200mmx2)	28-2-60	1
4-70	EL267063	Lamp (Cord Type) 8V 300 mA (300mmx2)	28-2-60	1
4-71	EL267208	Lamp (Cord Type) 8V 300 mA (400mmx2)	28-2-60	1
4-72	EF563703	△ Fuse 2A 250V (U/T, CSA)	39-1-50	1
4-73x	EF563681	△ Fuse 1A 250V	39-1-50	2
4-74x	EF296886	△ Fuse ST-6 2A (AAL)	39-1-63	4
4-75x	EF668474	△ Fuse (SEMKO T Type) 400 MAT	39-1-53	1
4-76x	EF623103	△ Fuse (SEMKO T Type)		1
4-77x	EF601301	△ Fuse (SEMKO T Type) 1AT 2AT	39-1-53	4
FINAL ASSEMBLY BLOCK				
4-78	SP292757	Bottom Plate (A)	AB-1517	1
4-79	SZ645243	Circular Foot A CA	CA-6014	4
4-80	ZS565942	Tapping Screw #2, 4x8(PAN)		4
RECEIVER P.C BOARD BLOCK				
4-81	EE655301	Front End FB512U13	57-2-35	1
4-82x	EE301419	Front End FB513U12 (CEE)	57-2-44	1
4-83	ES293308	Push SW. (3 throw) J-P7142	25-5-252	1
4-84	ES293275	Rotary SW. SR26(PH-2)N 1-3-4	25-6-109	1
4-85	EJ698051	Din Jack	31-1-158	1
4-86	EJ293365	4P Pin Jack	31-1-197	2
4-87	EV224954	Single axial 2 throw Vol. V16L4G1Z 250kx2	36-22-17	1
4-88	EV293343	Single axial 2 throw Vol. V16LG3B 250kx2	36-22-26	1
4-89	EV293354	Single axial 2 throw Vol. V16LG15C 100kx2	36-22-27	2

When ordering parts, Please describe Parts Number, Description, and Model Number in detail.

5. ILLUSTRATION OF AA-1125 ASSEMBLY BLOCK

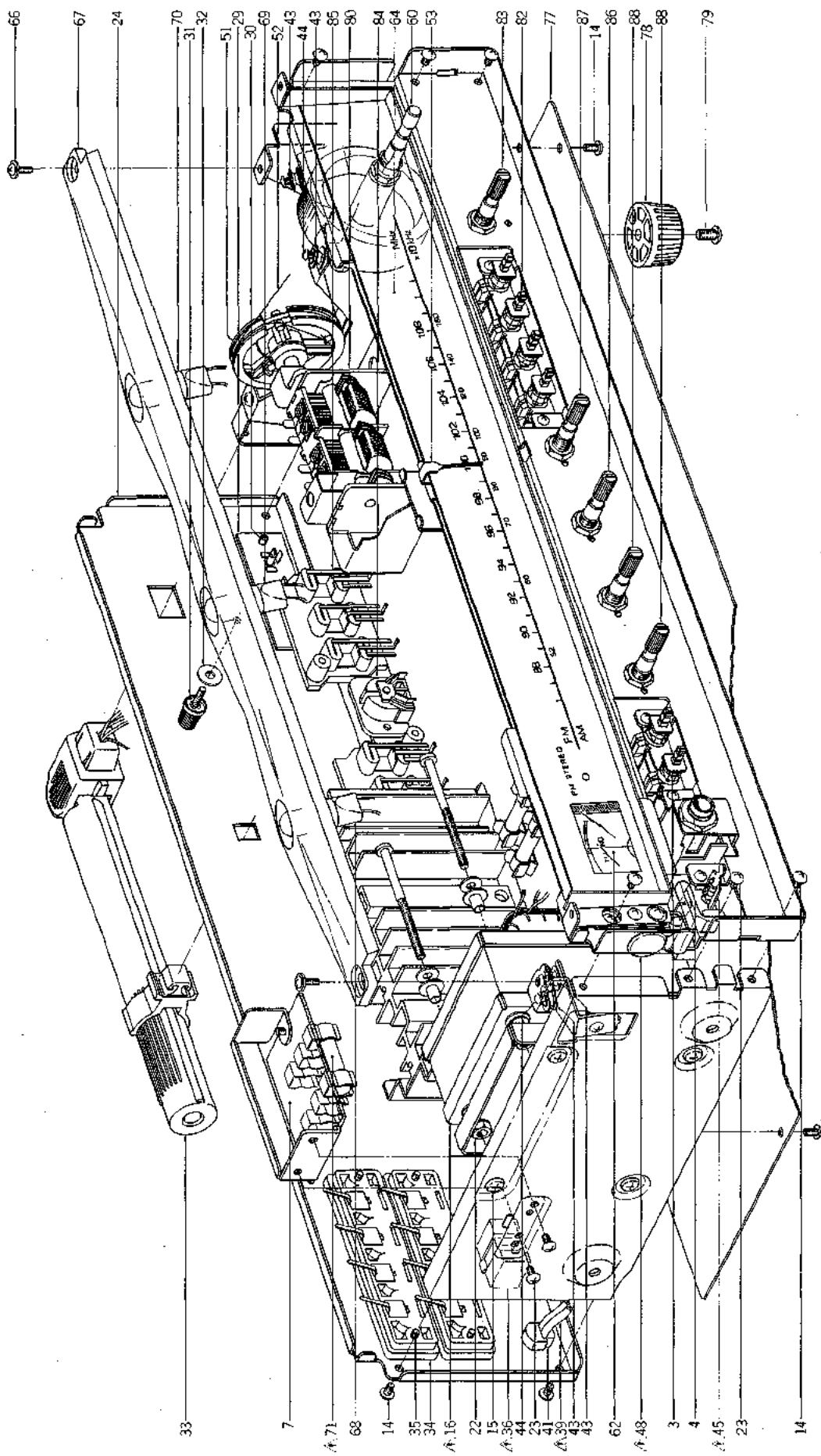

5) AA-1125 ASSEMBLY BLOCK

Ref. No.	Parts No.	Description	Schematic No.	Q'ty	Ref. No.	Parts No.	Description	Schematic No.	Q'ty
SPEAKER SW. P.C BOARD BLOCK									
5-1x	BA287065	Speaker SW. P.C Board Comp. AA-1125(U/T)	AB-2524	1	5-45	ES224436	△ Push SW. JP01(U/T,CSA)	25-5-221	1
5-2x	BA291036	Speaker SW. P.C Board Comp. AA-1125(CEE)	AB-2524	1	5-46x	ES239218	△ Push SW. JP01(TV-4) (AAL)	25-5-222	1
5-3	ES293501	Push Sw. (2 throw) J-P7111	25-5-251	1	5-47x	ES242346	△ Push SW. JP17(CEE)	25-5-224	1
5-4	EJ225022	Headphone Jack LJ255-1-12	31-2-77	1	5-48	EC204671	△ Ceramic/C. DD31-6 0.01μF(P) 500WV(U/T)	24-5-66	1
5-5x	ER511288	Metal Oxide Film/R. 1W 180 ohms(K)	35-15-10	2	5-49x	EC286198	△ Ceramic/C. AL-10 0.01μF(Z) 125WV (CSA, AAL)	24-5-69	1
LED P.C BOARD BLOCK									
5-6x	ED698826	LED SR-105D	45-15-16	1	5-50x	EC301320	△ MP/C. PME271Y447 4700PF 250WV(CEE)	24-9-118	2
FUSE P.C BOARD BLOCK									
5-7	BA300155	Fuse P.C Board 101 Comp. AA-1125(U/T)	AB-2526	1	5-51	MI650136	Dial Wheel D45 N01008	2-15-11	1
5-8x	BA300156	Fuse P.C Board 101 Comp. AA-1125(CEE)	AB-2526	1	5-52	TA207347	Thread D0.5 1600mm		1
COIL P.C BOARD BLOCK									
5-9x	EO539820	Peaking Coil 2.2μH(K)	23-1-187	1	5-53	TA299092	Pointer Part	AB-1527	1
HEAT-SINK BLOCK									
5-10x	ET293534	Transistor 2SC1986(R)(O)(Y)	45-1-264	2	5-54x	TA302724	Pointer BL Part (BL-U/T)	AB-1527	1
5-11x	ET293534	Transistor 2SA771(R)(O)(Y)	45-1-266	2	5-55x	TA299070	Pointer UL Part (AAL)	AB-1527	1
5-12x	ZW632226	Insulator Washer Bush M	45-16-27	4	5-56x	TA302802	Pointer UL BL Part(BL-AAL)	AB-1527	1
5-13x	ZS380046	Screw, pan head 3x10		4	5-57x	ZS417216	Screw, pan head 3x4		6
SIDE PLATE (L) BLOCK									
5-14	ZS325495	Tapping Screw #2, 3x6(BR)		25	5-58x	ZW562476	Earth Lug M3		1
5-15	ZS416687	Screw, binding head 4x8		4	5-59x	ZS447840	Tapping Screw #2, 3x8(BR)		1
5-16	BT293681	△ Power Trans. AA-1125T-1(U/T)	38-4-496	1	5-60	MF293714	Tuning Wheel	13-2-27	1
5-17x	BT296752	△ Power Trans. AA-1125T-2(CSA)	38-4-497	1	5-61x	ZS447761	Tapping Screw #2, 3x6(BR) (Black)		10
5-18x	BT296774	△ Power Trans. AA-1125T-4(AAL)	38-4-499	1	5-62	EM655727	Tuning Meter KL-218D-94	46-1-110	1
5-19x	BT295762	△ Power Trans. AA-1125T-3(CEE)	38-4-498	1	5-63x	EM288448	Tuning Meter KL-218D-103 (BL)		1
5-20x	ZW237857	Washer D4.1x10x1t		4	5-64	TA298980	Scale Plate	46-1-154	1
5-21x	ZW273914	Spring Washer		4	5-65x	TA302725	Scale Plate BL	AB-1513/ AB-1514	1
5-22	ZW413188	Nut M4, #1		4	5-66	ZS498273	Tapping Screw #2, 3x8, w/washer	AB-1513/ AB-1514	1
5-23	ZS417216	Screw, pan head 3x4		8	5-67	TA298934	Illumination Plate	AB-1515	1
REAR PANEL BLOCK									
5-24	SP293040	Rear Panel (1) (U/T)	AB-2508	1	5-68	EL267197	Lamp (Cord Type) 8V 300 MA (200mmx2)	28-2-60	1
5-25x	SP293038	Rear Panel (2) (CSA)	AB-2508	1	5-69	EL267063	Lamp (Cord Type) 8V 300 MA (300mmx2)	28-2-60	1
5-26x	SP293141	Rear Panel (3) (AAL)	AB-2509	1	5-70	EL267208	Lamp (Cord Type) 8V 300 MA (400mmx2)	28-2-60	1
5-27x	SP293051	Rear Panel (4) (CEE)	AB-2509	1	5-71	EF562691	△ Fuse 2.5A 250V	39-1-50	1
5-28x	SP293163	Rear Panel (5) (BEAB)	AB-2510	1	5-72x	EF590692	△ Fuse 1.2A 250V	39-1-50	1
5-29	EJ293646	3P Antenna Terminal Plate	32-1-78	1	5-73x	EF296875	△ Fuse ST-6 2.5A	39-1-63	1
5-30	ZW698308	Nylon Rivet (FNPR) 3x5.5 (Black)	2-7-54	3	5-74x	EF601301	△ Fuse (SEMKO T Type) 2AT	39-1-53	1
5-31	SK652397	Knob 0512-2	34-1-4	1	5-75x	EF623103	△ Fuse (SEMKO T Type) 1AT	39-1-53	1
5-32	ZW651082	Washer (SPC) D3.2x10x1t		1	5-76x	EF602550	△ Fuse (SEMKO T Type) 1.25AT 250V	39-1-53	4
5-33	EE293657	Bar Antenna	55-1-51	1	FINAL ASSEMBLY BLOCK				
5-34	EJ240581	4P Push Terminal	32-1-72	2	5-77	SP300695	Bottom Plate (B)	AB-1517	1
5-35	ZS522865	Tapping Screw #2, 3x12(BR)		8	5-78	SZ645243	Circular Foot A CA	CA-6014	4
5-36	EJ293668	△ AC Consent S-16432 (U/T, CSA, AAL)	31-1-147	1	5-79	ZS565942	Tapping Screw #2, 4x8(PAN)		4
5-37x	EJ296853	△ 3P In-Let CM-3 (CEE, BEAB)	31-1-199	1	RECEIVER P.C BOARD BLOCK				
5-38x	ZS463353	Tapping Screw #2, 3x8(BR) (CEE, BEAB)		1	5-80	EE655301	Front End FB512U13	57-2-35	1
5-39	EW374894	△ AC Cord CUL 3M(U/T)	26-9-19	1	5-81x	EE301419	Front End FB513U12 (CEE)	57-2-44	1
5-40x	EW207742	△ AC Cord CUL(CSA,AAL)	26-3-45	1	5-82	ES293310	Push SW. (4 throw) J-P7143	25-5-253	1
5-41	EZ631945	Strain Relief SR-4N-4 (U/T, CSA, AAL)	2-7-49	1	5-83	ES293275	Rotary SW. SR26(PH-2)N 1-3-4	25-6-109	1
5-42x	ZW273767	Earth Lug D3x20L		1	5-84	EJ698051	Djn Jack	31-1-158	1
5-43	MR530662	Roller B	91-5009	2	5-85	EJ293376	6P Pin Jack	31-1-198	2
5-44	ZS530673	Roller Screw A	91-5010	2	5-86	EV224954	Single axial 2 throw Vol. V16L4G1Z 250kx2	36-22-17	1
					5-87	EV293343	Single axial 2 throw Vol. V16LG3B 250kx2	36-22-26	1
					5-88	EV293354	Single axial 2 throw Vol. V16LG15C 100kx2	36-22-27	2

When ordering parts, Please describe Parts Number, Description, and Model Number in detail.

6. PHOTO OF AA-1115 FINAL ASSEMBLY BLOCK

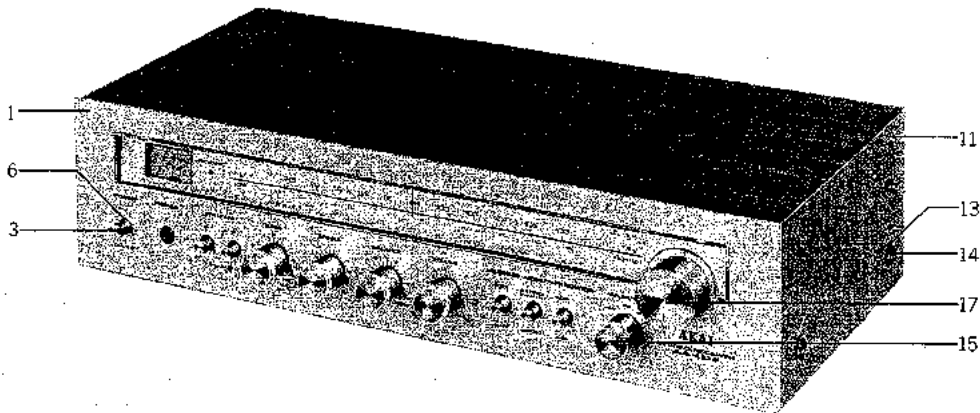

6) AA-1115 FINAL ASSEMBLY BLOCK

Ref. No.	Parts No.	Description	Schematic No.	Q'ty
FRONT PANEL BLOCK				
6-1	BD300013	Front Panel Block Comp.	AB-1535	1
6-2x	BD303264	Front Panel Block Comp.(BL)	AB-1535	1
6-3	SK286367	Push Button Knob (A)	AC-3537	6
6-4x	SK301304	Push Button Knob (C)	AC-3562	6
6-5x	ZG286435	Taper Spring	AC-3536	6
6-6	SE286560	Button Escutcheon (B)	AC-3538	3
FINAL ASSEMBLY BLOCK				
6-7x	ZS447840	Tapping Screw #2, 3x8(BR)		5
6-8x	ZW659182	Adjust. Washer (U) D4.5x10x0.4t		1
6-9x	ZW659193	Adjust. Washer (U) D4.5x10x0.5t		1
6-10x	ZS325495	Tapping Screw #2, 3x6(BR)		5
6-11	BC298890	Cabinet	AB-1525	1
6-12x	BC302692	Cabinet (BL)	AB-1525	1
6-13	ZW548010	Spot Facing Washer	MU-6028	4
6-14	ZS510344	Screw, binding head 4x12		4
6-15	SK646317	Single Knob	AA-5250	5
6-16x	SK281564	Single Knob (BL)	AA-5250	5
6-17	SK223705	Tuning Knob	T2-5019	1
6-18x	SK267445	Tuning Knob (BL)	T2-5019	1

When ordering parts, Please describe Parts Number, Description, and Model Number in detail.

7. PHOTO OF AA-1125 FINAL ASSEMBLY BLOCK

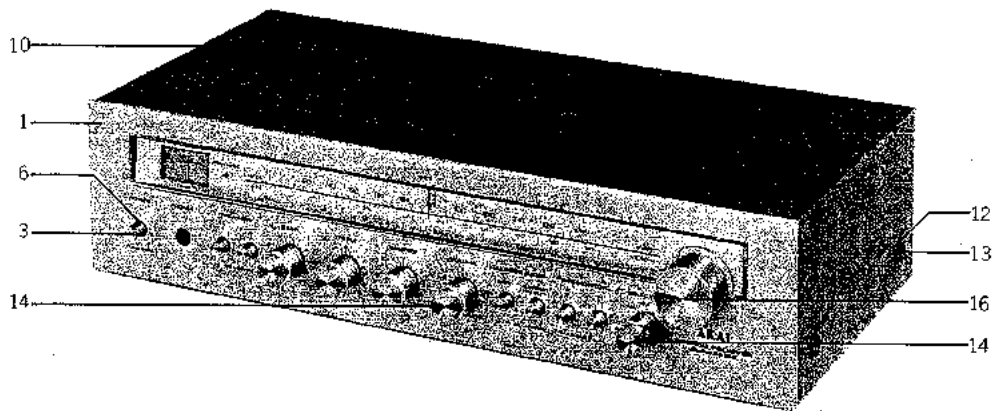

7) AA-1125-FINAL ASSEMBLY BLOCK

Ref. No.	Parts No.	Description	Schematic No.	Q'ty
FRONT PANEL BLOCK				
7-1	BD300015	Front Panel Block Comp. AA-1125	AB-1535	1
7-2x	BD303265	Front Panel Block Comp. AA-1125-BL	AB-1535	1
7-3	SK286367	Push Button Knob (A)	AC-3537	7
7-4x	SK301304	Push Button Knob (C) (BL)	AC-3562	7
7-5x	ZG286435	Taper Spring	AC-3536	7
7-6	SE286560	Button Escutcheon (B)	AC-3538	3.5
FINAL ASSEMBLY BLOCK				
7-7x	ZS447840	Tapping Screw #2, 3x8(BR)		3
7-8x	ZW659182	Adjust. Washer (U) D4.5x10x0.4t		1
7-9x	ZW659193	Adjust. Washer (U) D4.5x10x0.5t		1
7-10	BC298890	Cabinet	AB-1525	1
7-11x	BC302692	Cabinet (BL)	AB-1525	1
7-12	ZW548010	Spot Facing Washer	MU-6028	4
7-13	ZS510344	Screw, binding head 4x12		4
7-14	SK646817	Single Knob	AA-5250	5
7-15x	SK281564	Single Knob (BL)	AA-5250	5
7-16	SK223705	Tuning Knob	T2-5019	1
7-17x	SK267445	Tuning Knob (BL)	T2-5019	1

8. LIST OF INTERCHANGEABLE SEMICONDUCTORS

As far as service is concerned, in case the original parts cannot be obtained, the interchangeable parts listed below can be substituted.

Original Parts			Interchangeable Parts	
Description	Parts No.	Utilizing P.C Board	Description	Parts No.
2SA711 (R) (O) (Y)	ET293545	AB-2501A/2513A		
2SA733 (P) (Q) (R)	ET539122	AB-1501A/1530A AB-2501A/2513A	2SA564 (Q) (R) 2SA628 (D) (E) (F) (G)	ET538154 ET539144
2SA817 (O) (Y)	ET293253	AB-1501A/1530A AB-2501A/2513A	2SB560 (E) (F) 2SA815 (O) (Y)	ET219868 ET649708
2SA872 (D1) (D2) (D3) (E1) (E2) (E3)	ET293218	AB-1501A/1530A AB-2501A/2513A	2SA640-1 (E) (F) (G) (H)	ET204221
2SC930 (E) (F)	ET618873	AB-1501A/1530A AB-2501A/2513A	2SC454 (B) (C) 2SC839 (E)	ET591366 ET575313
2SC945L (K) (P) (Q)	ET632204	AB-1501A/1530A AB-2501A/2513A	2SC536 (F) (G) (H) 2SC711 (F) (G) (H)	ET632215 ET621268
2SC1400 (E) (F)	ET293264	AB-1501A/1530A AB-2501A/2513A	2SC1627 (O) (Y) 2SD438 (E) (F)	ET293254 ET219857
2SC1449 (K) (L)	ET649034	AB-1501A/1530A AB-2501A/2513A	2SD313 (E) (F)	ET452531
2SC1627 (O) (Y)	ET293253	AB-1501A/1530A AB-2501A/2513A	2SD438 (E) (F)	ET219857
2SC1986 (R) (O) (Y)	ET293534	AB-2501A/2513A		
2SD313 (E) (F)	ET452531	AB-1501A/1530A	2SC1061 (A) (B) (C)	ET371880
1S2473	ED624903	AB-1501A/1530A AB-2501A/2513A	1S1588 WG711	ED557447 ED515990
GP15D	ED219903	AB-1501A/1530A AB-2501A/2513A	10D1	ED539976
RD13E (B)	ED223558	AB-1501A/1530A	WZ-130	ED539976
RD13E (C)	ED300829	AB-2501A/2513A	WZ-130	ED539976
SR-105D	ED293523	AB-1501D/1530D AB-2501D/2513D		

INDEX

Parts No.	Ref. No. & Symbol No.	Parts No.	Ref. No. & Symbol No.	Parts No.	Ref. No. & Symbol No.	Parts No.	Ref. No. & Symbol No.	Parts No.	Ref. No. & Symbol No.
BA287065	5-1x	EF296875	5-73x	ES239218	5-46x	SK301304	6-4x	ZW413188	5-22
BA287076	4-2x	EF296886	4-74x	ES242346	4-49x	SK301304	7-4x	ZW548010	6-13
BA287087	4-1x	EF562691	5-71	ES242346	5-47x	SK267445	6-18x	ZW548010	7-12
BA291036	5-2x	EF563681	4-73x	ES293275	2-SW5	SK646817	6-15	ZW562476	5-58x
BA297775	2-1	EF563703	4-72	ES293275	3-SW5	SK646817	7-14	ZW632226	4-11x
BA297786	2-4	EF590692	5-72x	ES293275	4-84	SK652397	4-30	ZW632226	5-12x
BA297797	3-1	EF601301	4-77x	ES293275	5-83	SK652397	5-31	ZW651082	4-31
BA297808	3-4	EF601301	5-74x	ES293308	2-SW1,2,3	SP292757	4-78	ZW651082	5-32
BA300143	2-2	EF602550	5-76x	ES293308	4-83	SP293038	5-25x	ZW659182	6-8x
BA300144	3-2	EF623103	4-76x	ES293310	3-SW1 to4	SP293040	5-24	ZW659182	7-8x
BA300153	4-7	EF623103	5-75x	ES293310	5-82	SP293051	5-27x	ZW659193	6-9x
BA300154	4-8x	EF668474	4-75x	ES2933501	4-3	SP293141	5-26x	ZW659193	7-9x
BA300155	5-7	EI293185	2-IC3	ES293501	5-3	SP293163	5-28x	ZW698308	4-29
BA300156	5-8x	EI293185	3-IC3	ET293218	2-TR4,5	SP298721	4-24x	ZW698308	5-30
BA301507	2-3	EI293207	2-IC2	ET293218	3-TR4,5	SP298732	4-23		
BA301508	3-3	EI293207	3-IC2	ET293220	2-TR9	SP298743	4-27x		
BC298890	6-11	EI650586	2-IC1	ET293220	3-TR9	SP298754	4-26x		
BC298890	7-10	EI650586	3-IC1	ET293253	2-TR8	SP298765	4-25x		
BC302692	6-12x	EI697871	2-IC4	ET293253	2-TR17	SP300695	5-77		
BC302692	7-11x	EI697871	3-IC4	ET293253	3-TR8	SZ645243	4-79		
BD300013	6-1	EJ225022	4-4	ET293253	3-TR17	SZ645243	5-78		
BD300015	7-1	EJ225022	5-4	ET293264	2-TR6	TA207347	4-58		
BD303264	6-2x	EJ240581	4-33	ET293264	3-TR6	TA207347	5-52		
BD303265	7-2x	EJ240581	5-34	ET293534	5-10x	TA298934	4-68		
BT293398	2-T4	EJ293365	2-2	ET293534	5-11x	TA298934	5-67		
BT293398	3-T4	EJ293365	4-86	ET452531	4-10x	TA298980	4-65		
BT293670	4-15	EJ293376	3-2	ET539122	2-TR2,3	TA298990	5-64		
BT293681	5-16	EJ293376	5-85	ET539122	3-TR2,3	TA299070	4-61x		
BT295762	5-19x	EJ293646	4-28	ET539122	3-TR18	TA299070	5-55x		
BT296730	4-16x	EJ293646	5-29	ET618873	2-TR1	TA299092	4-59		
BT296752	5-17x	EJ293668	4-35	ET618873	3-TR1	TA299092	5-53		
BT296763	4-17x	EJ293668	5-36	ET632204	2-TR7	TA302724	4-60x		
BT296774	5-18x	EJ296853	4-36x	ET632204	2-TR12to15	TA302724	5-54x		
BT296785	4-18x	EJ296853	5-37x	ET632204	2-TR19	TA302725	4-66x		
BT697950	2-T3	EJ514822	2-8	ET632204	3-TR7	TA302725	5-65x		
BT697950	3-T3	EJ514822	3-8	ET632204	3-TR12to15	TA302802	4-62x		
EC204671	4-50	EJ592503	2-9	ET632204	3-TR19	TA302802	5-56x		
EC204671	5-48	EJ592503	3-9	ET649034	2-TR16	ZG286435	6-5x		
EC286198	4-51x	EJ698051	2-1	ET649034	3-TR16	ZG286435	7-5x		
EC286198	5-49x	EJ698051	3-1	EV224954	2-VR3	ZS325495	2-5		
EC293400	2-C50,51	EJ698051	4-85	EV224954	3-VR3	ZS325495	3-5		
EC293602	2-C20	EJ698051	5-84	EV224954	4-87	ZS325495	4-13		
EC293602	3-C20	EL267063	4-70	EV224954	5-86	ZS325495	5-14		
EC300742	3-C50,51	EL267063	5-69	EV269572	2-VR5	ZS325495	6-10x		
EC301320	4-52x	EL267197	4-69	EV269572	3-VR5	ZS379350	4-12x		
EC301320	5-50x	EL267197	5-68	EV293343	2-VR4	ZS380046	5-13x		
EC538244	2-C17	EL267208	4-71	EV293343	3-VR4	ZS416687	4-14		
EC538244	3-C17	EL267208	5-70	EV293343	4-88	ZS416687	5-15		
EC559181	2-C16	EM288448	4-64x	EV293343	5-87	ZS417216	4-22		
EC559181	3-C16	EM288448	5-63x	EV293354	2-VR6,7	ZS417216	5-23		
EC650406	2-C55	EM655727	4-63	EV293354	3-VR6,7	ZS417216	5-57x		
EC650406	3-C55	EM655727	5-62	EV293354	4-89	ZS421740	4-42x		
EC666494	2-C18	EO250143	2-L4	EV293354	5-88	ZS447761	4-56x		
EC666494	3-C18	EO250143	3-L4	EV464231	2-VR8	ZS447761	5-61x		
EC684720	2-C73	EO293387	2-T2	EV464231	3-VR8	ZS447840	4-54x		
EC684720	3-C73	EO293387	3-T2	EV484863	2-VR2	ZS447840	5-59x		
ED219903	2-D5to8	EO539820	2-L5	EV484863	3-VR2	ZS447840	6-7x		
ED219903	3-D5to8	EO539820	3-L5	EV499364	2-VR1	ZS447840	7-7x		
ED300829	2-D4	EO539820	4-9x	EV499364	3-VR1	ZS463353	4-37x		
ED300829	3-D4	EO539820	5-9x	EW207742	4-39x	ZS463353	5-38x		
ED300946	2-D11	EO650608	2-T1	EW207742	5-40x	ZS498273	4-67		
ED300946	3-D11	EO650508	3-T1	EW374894	4-38	ZS498273	5-66		
ED624903	2-D1	EO650610	2-L1	EW374894	5-39	ZS510344	6-14		
ED624903	2-D3	EO650610	3-L1	EZ631945	4-40	ZS510344	7-13		
ED624903	2-D12	EO697915	2-L2,3	EZ631945	5-41	ZS522865	4-34		
ED624903	3-D1	EO697915	3-L2,3	MF293714	4-55	ZS522865	5-35		
ED624903	3-D3	EO698826	4-6x	MF293714	5-60	ZS530673	4-46		
ED624903	3-D9,10	ER293635	2-FR1	MF650136	4-57	ZS530673	5-44		
ED624903	3-D12	ER293635	3-FR1	MR530662	5-51	ZS565942	4-80		
ED698826	5-6x	ER511288	4-5x	MR530662	4-45	ZS565942	5-79		
EE293657	4-32	ER511288	5-5x	MR530662	5-43	ZW237857	4-19x		
EE293657	5-33	ER552712	2-R47	SE286560	6-6	ZW237857	5-20x		
EE301419	2-7	ER552712	2-R50	SE286560	7-6	ZW273756	4-44x		
EE301419	3-7	ER552712	3-R47	SK223705	6-17	ZW273767	4-41x		
EE301419	4-82x	ER552712	3-R50	SK223705	7-16	ZW273767	4-53x		
EE301419	5-81x	ER650430	2-FL1,2	SK267445	7-17x	ZW273767	5-42x		
EE655301	2-6	ER650430	3-FL1to3	SK281564	6-16x	ZW273802	4-43x		
EE655301	3-6	ES224436	4-47	SK281564	7-15x	ZW273914	4-20x		
EE655301	4-81	ES224436	5-45	SK286367	6-3	ZW273914	5-21x		
EE655301	5-80	ES239218	4-48x	SK286367	7-3	ZW413188	4-21		

SECTION 3

SCHEMATIC DIAGRAM

1. AA-1115 NO. 3-1 1541650A SCHEMATIC DIAGRAM
2. AA-1125 NO. 3-2 1541651A SCHEMATIC DIAGRAM
3. AA-1115, 1125 NO. 3-3 1541652A SCHEMATIC DIAGRAM

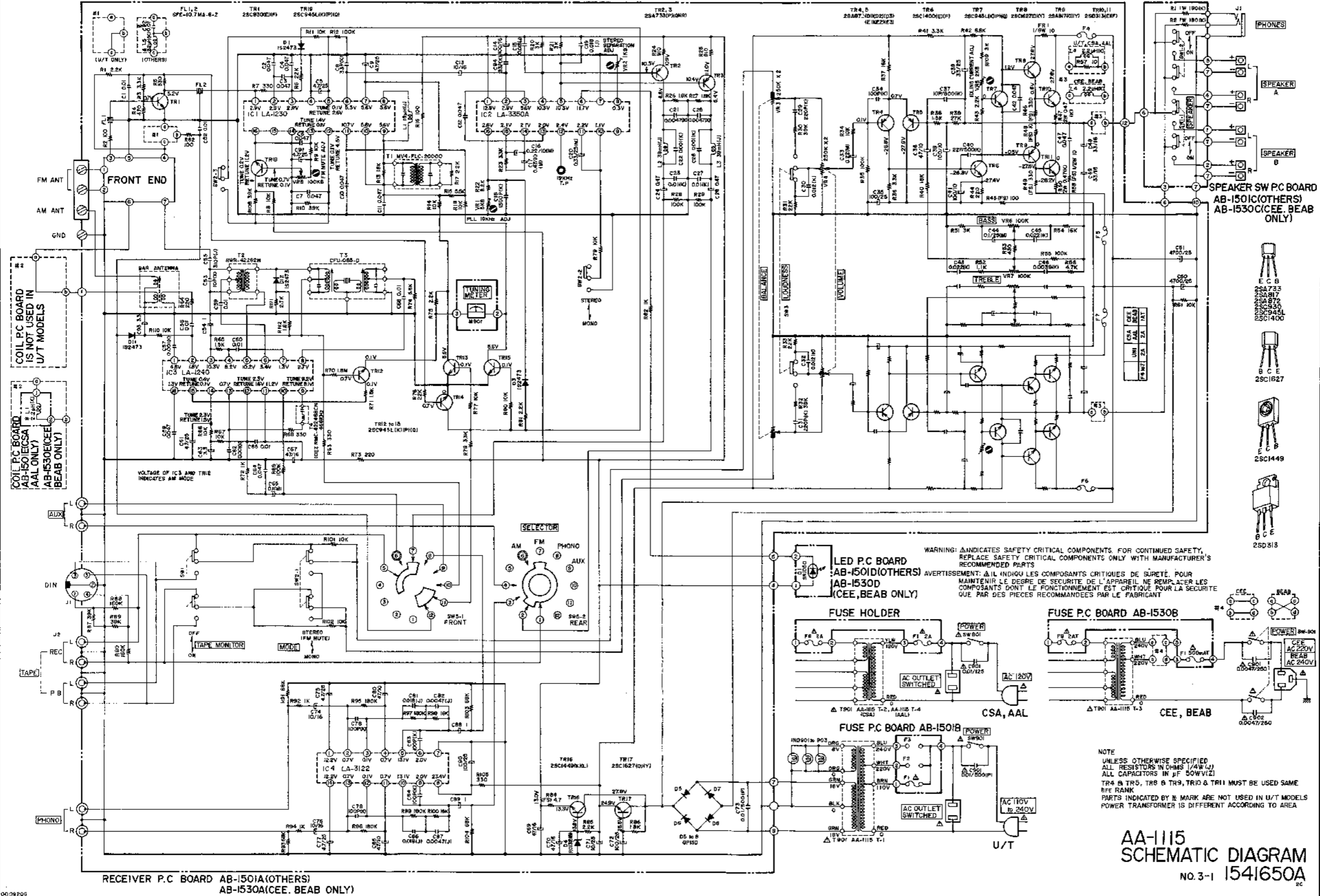

AA-1115
SCHEMATIC DIAGRAM
 NO. 3-1 1541650A

AA-1115,1125

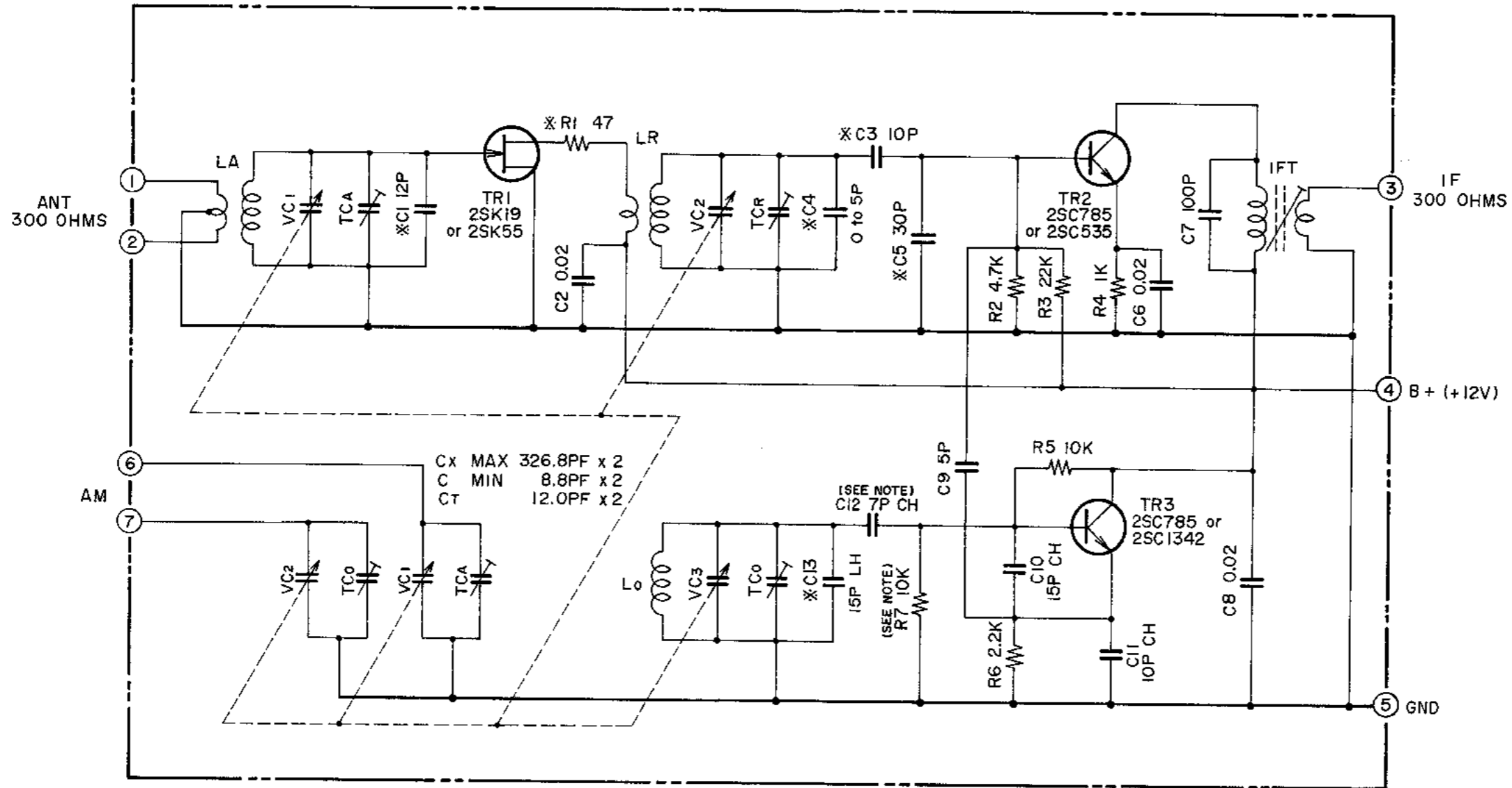

NOTE
 1. UNLESS OTHERWISE SPECIFIED
 ALL RESISTORS IN OHMS
 ALL CAPACITORS IN μ F
 2. * MARK : FACTORY ADJUSTED
 3. R7 : 6.8K OHMS (CEE MODEL)
 C12 : 5PF CH (CEE MODEL)
 4. CEE MODEL : FB513U12
 OTHERS MODEL : FB512U14

AA-1115,1125
 FRONT END
 SCHEMATIC DIAGRAM
 NO.3-3 1541652A

AA-1115,1125

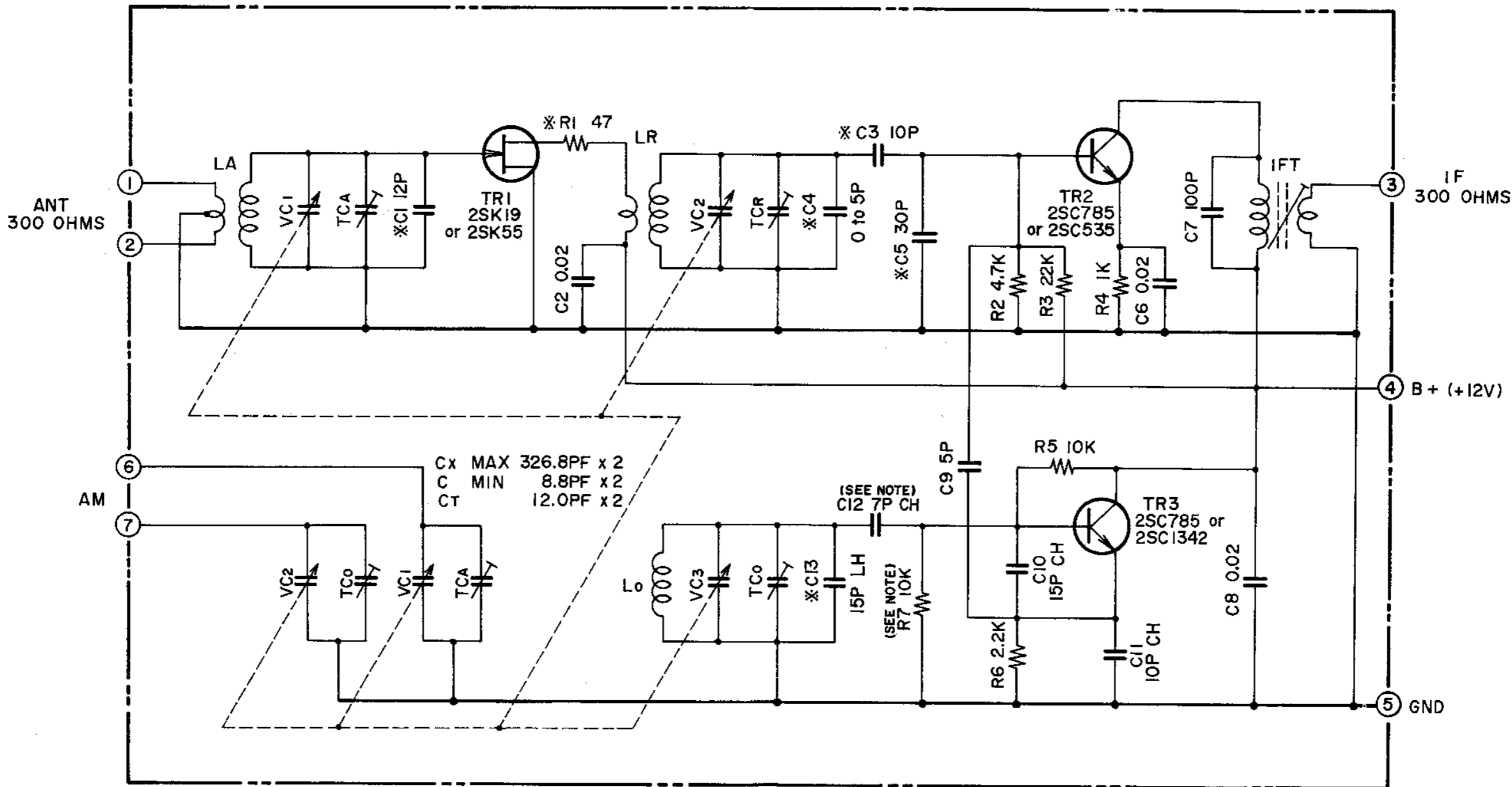

NOTE
 1. UNLESS OTHERWISE SPECIFIED
 ALL RESISTORS IN OHMS
 ALL CAPACITORS IN μ F
 2. * MARK : FACTORY ADJUSTED
 3. R7 : 6.8K OHMS (CEE MODEL)
 C12 : 5PF CH (CEE MODEL)
 4. CEE MODEL : FB513U12
 OTHERS MODEL : FB512U14

AA-1115,1125
 FRONT END
 SCHEMATIC DIAGRAM
 NO.3-3 1541652A

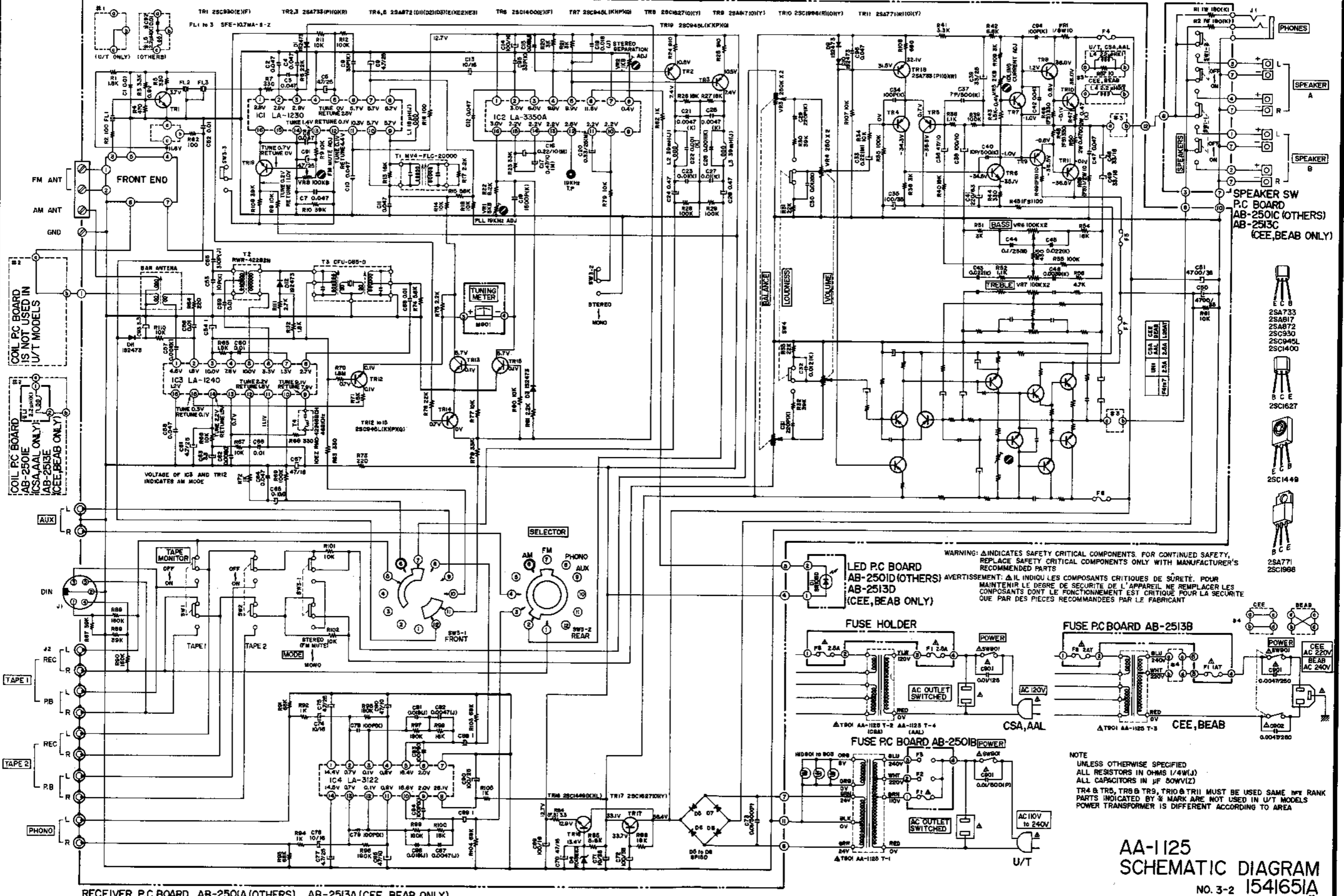

AA-1125
SCHEMATIC DIAGRAM
NO. 3-2 154165IA

NOTE
UNLESS OTHERWISE SPECIFIED
ALL RESISTORS IN OHMS 1/4W(1)
ALL CAPACITORS IN μF 50WV(2)
TR4 & TR5, TR8 & TR9, TR10 & TR11 MUST BE USED SAME RPT RANK
PARTS INDICATED BY 1/2 MARK ARE NOT USED IN U/T MODELS
POWER TRANSFORMER IS DIFFERENT ACCORDING TO AREA

WARNING: Δ INDICATES SAFETY CRITICAL COMPONENTS. FOR CONTINUED SAFETY, REPLACE SAFETY CRITICAL COMPONENTS ONLY WITH MANUFACTURER'S RECOMMENDED PARTS
AVERTISSEMENT: Δ IL INDIQUE LES COMPOSANTS CRITIQUES DE SÛRETÉ. POUR MAINTENIR LE DEGRÉ DE SECURITE DE L'APPAREIL NE REMPLACER LES COMPOSANTS DONT LE FONCTIONNEMENT EST CRITIQUE POUR LA SECURITE QUE PAR DES PIÉCES RECOMMANDÉES PAR LE FABRICANT

- EEB
- 2SA733
- 2SA817
- 2SA872
- 2SC930
- 2SC945L
- 2SC1400
- BCE
- 2SC1627
- EEB
- 2SC1449
- BCE
- 2SA771
- 2SC1998

COIL PC BOARD
AB-250IE
ICSA, AAL ONLY: L30
AB-2513E
(CEE, BEAB ONLY)

RECEIVER P.C BOARD AB-250IA (OTHERS) AB-2513A (CEE, BEAB ONLY)

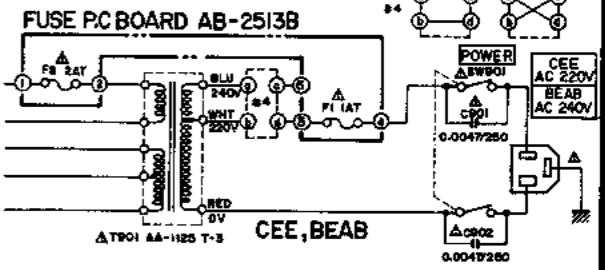
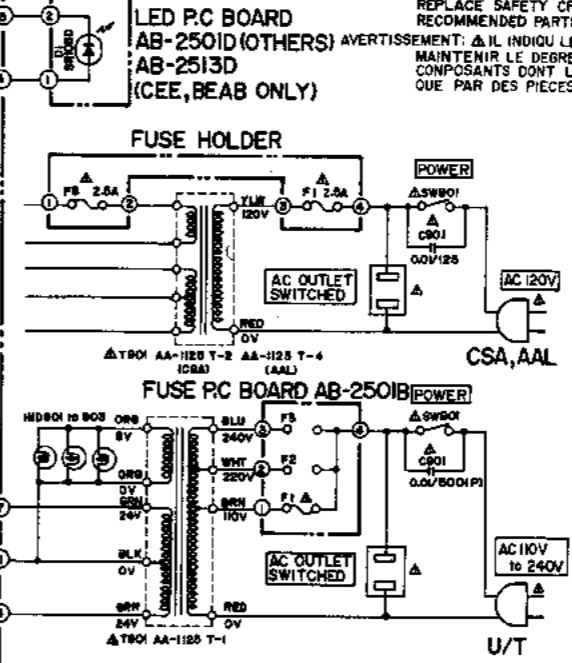

MODEL AA-1125 P.C BOARD EXPLODED VIEW (CEE, BEAB)

