

AA-5210

SERVICE MANUAL

PARTS LIST



AKAI STEREO AMPLIFIER

MODEL **AA-5210**

ALSO APPLICABLE TO MODEL AA-5210DE3

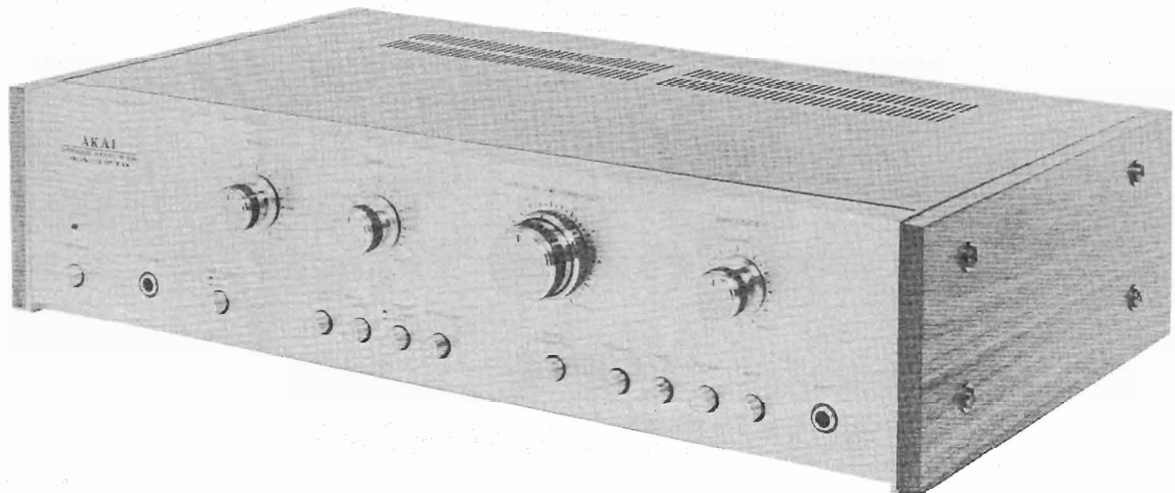

STEREO AMPLIFIER

MODEL AA-5210

ALSO APPLICABLE TO MODEL AA-5210DB
STEREO AMPLIFIER

SECTION 1 SERVICE MANUAL	2
SECTION 2 PARTS LIST	13
SECTION 3 SCHEMATIC DIAGRAM	28

SECTION 1
SERVICE MANUAL

TABLE OF CONTENTS

I. SPECIFICATIONS	3
II. DISMANTLING OF UNIT	4
III. ADJUSTMENTS.....	5
1. NECESSARY MEASURING INSTRUMENTS	5
2. CLASSIFICATION OF VARIOUS P.C. BOARDS	5
3. DOLBY N.R. ADJUSTMENT	5
4. MAIN AMP. ADJUSTMENT	7
IV. COMPOSITE VIEWS OF COMPONENTS	10

I. SPECIFICATIONS

An asterisk next to a figure indicates the minimum guaranteed performance.

RATED OUTPUT		15W x 2/8Ω (both channels activated)
HARMONIC DISTORTION		0.5% (8Ω) at rated output
POWER BAND WIDTH (IHF)		15 to 80,000 Hz *20 to 50,000 Hz at 1% distortion
INPUT SENSITIVITY	PHONO	2.75 mV (-49 dBm ±1.5 dB)
	MIC	2.75 mV (-49 dBm ±1.5 dB)
		0.85 mV (-59 dBm ±1.5 dB) ... AA-5210DB
	TUNER	155 mV (-14 dBm ±1.5 dB)
	AUX	155 mV (-14 dBm ±1.5 dB)
	TAPE	155 mV (-14 dBm ±1.5 dB)
RESIDUAL NOISE		Less than 1.4 mV (Less than -55 dBm)
SIGNAL TO NOISE RATIO	PHONO	Better than 37 dBm input shorted
	MIC	Better than 37 dBm input shorted
	TUNER	Better than 47 dBm input open
	AUX	Better than 47 dBm input open
	TAPE	Better than 47 dBm input open
TONE CONTROL	BASS	10 ±1.5 dB at 100 Hz -10 ±1.5 dB at 100 Hz
	TREBLE	10 ±1.5 dB at 10 kHz -10 ±1.5 dB at 10 kHz
LOUDNESS CONTROL		7 ±1.5 dB at 100 Hz 5 ±1.5 dB at 10 kHz
PHONO FREQUENCY RESPONSE		RIAA ±1 dB *13 ±1.5 dB at 100 Hz *-14 ±1.5 dB at 10 kHz
CHANNEL SEPARATION		Better than 50 dB at 1 kHz
L-R DEVIATION		Within 2 dB
RECORDING OUTPUT	PIN	140 mV (-15 ±1.5 dB)
	DIN	27 mV (-29 ±1.5 dB)
TRANSISTORS		2SA628 (E) (F) ... 0 (4) 2SC1312 (G) (H) ... 6 (6) 2SA720 (P) (Q) ... 2 (2) 2SC1312R (G) (H) ... 0 (10) 2SA725 (G) ... 2 (2) 2SC1313(F) (G) (H) ... 4 (2) 2SC711 (E) (F) (G) ... 0 (8) 2SC1318 (P) (Q) ... 4 (4) 2SC1061 (B) (C) ... 4 (4) 2SD313 (E) (F) ... 0 (1) 2SC1247A (B)(V) ... 1 (0) 2SD361 (D) (E) ... 0 (1)
F.E.T.		2SK30A (GR) ... 0 (2)
DIODES		10D-1 ... 0 (4) 1N4002 ... 4 (0)
		HIFI SPECIAL 400V 3A ... 4 (4) 1S2473VE ... 0 (6)
		1N34A ... 0 (8) ZW085 ... 0 (2)
		ZW240 ... 0 (1)
THERMISTERS		24D26 ... 0 (1)
VARISTORS		VD1222 ... 2 (2)
POWER SOURCE		100 to 240V A.C. 50/60 Hz
POWER CONSUMPTION		120W ... AA-5210, 150W ... AA-5210DB
DIMENSIONS		450(W) x 108(H) x 290(D) mm ... AA-5210 (17.7" x 4.2" x 11.4") 529(W) x 108 (H) x 340(D) mm ... AA-5210DB (20.8" x 4.3" x 13.4")
WEIGHT		7.2 kg (15.8 lbs.) ... AA-5210
		9.6 kg (21.1 lbs.) ... AA-5210DB

- NOTES: 1. The Transistors, F.E.T. Diodes, Thermistors and Varistors for model AA-5210DB are shown in parentheses.
2. Specifications subject to change without notice.

II. DISMANTLING OF UNIT

In case of trouble, etc. necessitating disassembly, please disassemble in the order shown in photographs. Reassemble in reverse order.

1

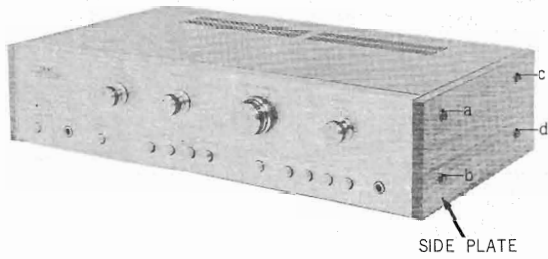

2

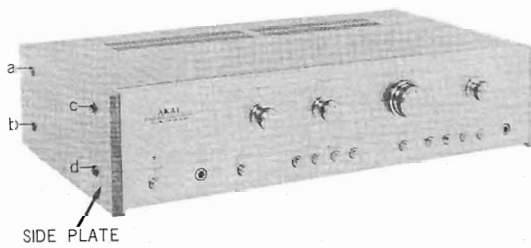

3

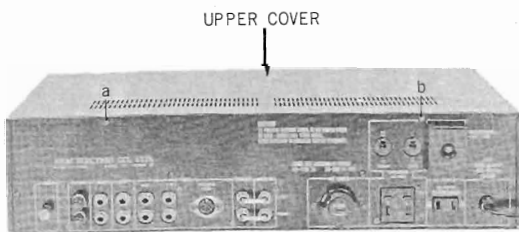

4

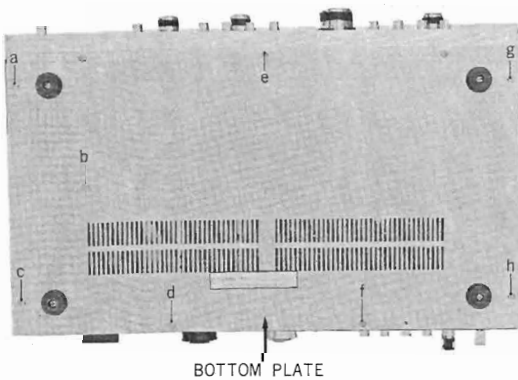

5

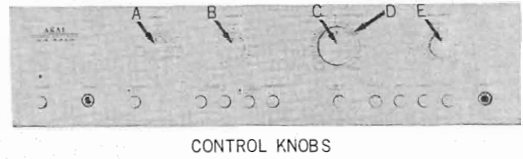

6

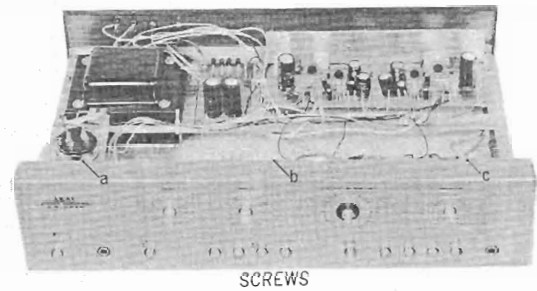

7

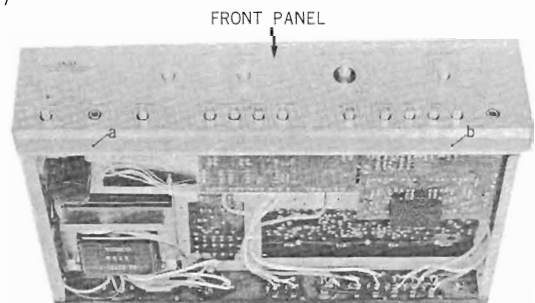

8

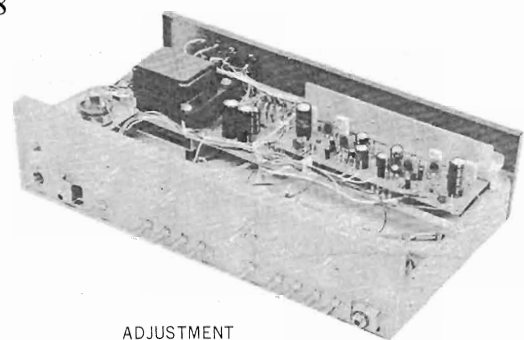

III. ADJUSTMENT

1. NECESSARY MEASURING INSTRUMENT

Measuring Instruments	Model	For
HIGH SENSITIVITY A.C. VOLTMETER	Kikusui 183E	DOLBY N.R. ADJUSTMENT
RC OSCILLATOR	Kikusui 418	
FREQUENCY COUNTER	National VP-475	
AMPERE METER OR TESTER	Yokogawa 2011	MAIN AMP. ADJUSTMENT
V.T.V.M. or Tester	Kikusui 107A	
Oscilloscope		

2. CLASSIFICATION OF VARIOUS P.C. BOARDS

P.C. Board	AA-5210	AA-5210DB
MAIN AMP. P.C. BOARD	96-5008	96-5008
EQUALIZER P.C. BOARD	A5-5028	A5-5083
TONE CONTROL P.C. BOARD	A5-5029	A5-5029
POWER SUPPLY P.C. BOARD	A5-5026	A5-5047
SWITCH P.C. BOARD	A5-5061	A5-5045
SPEAKER SW. P.C. BOARD	A5-5027	
DOLBY N.R. P.C. BOARD		A5-5046

3. DOLBY N.R. ADJUSTMENT

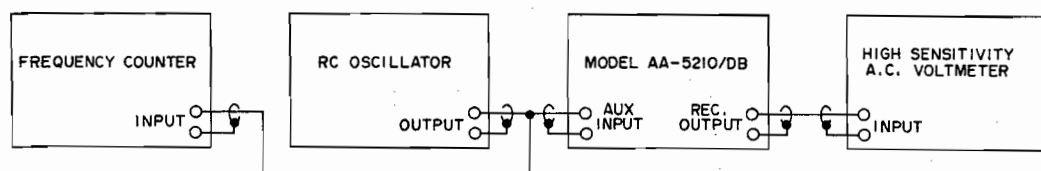

Fig. 1

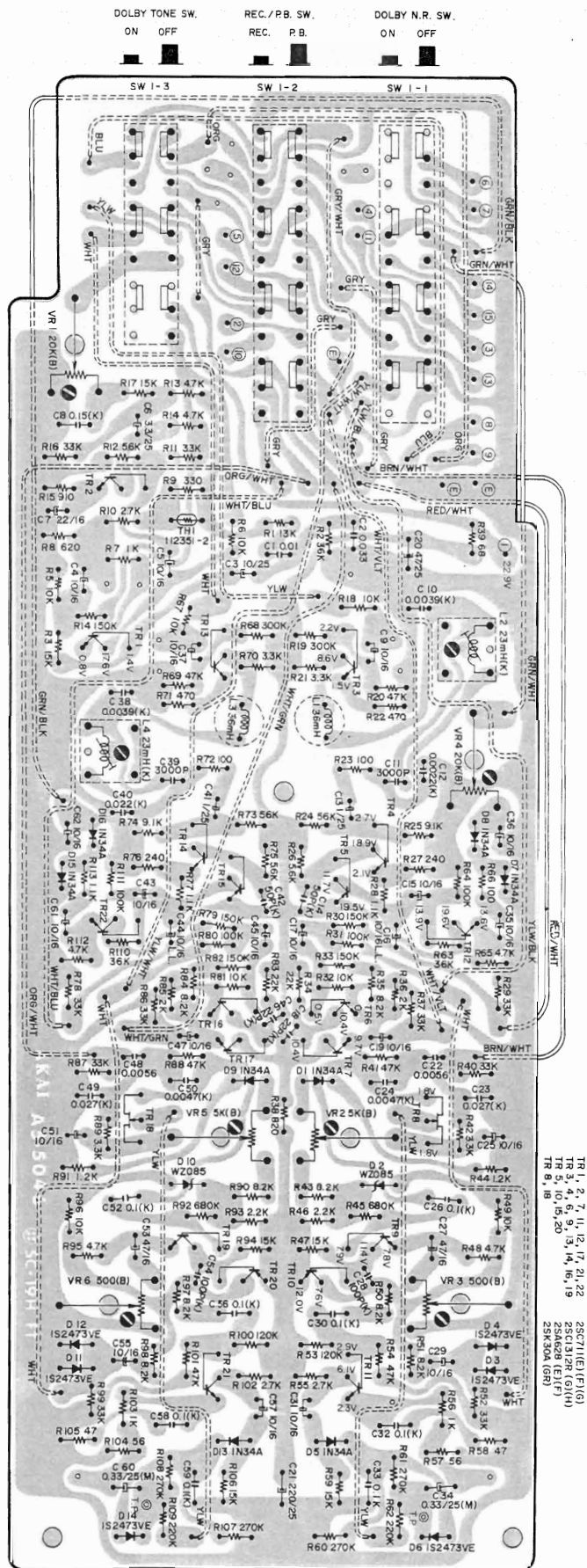

Fig. 2 DOLBY N.R. P.C. BOARD A5-5046 (reverse side)

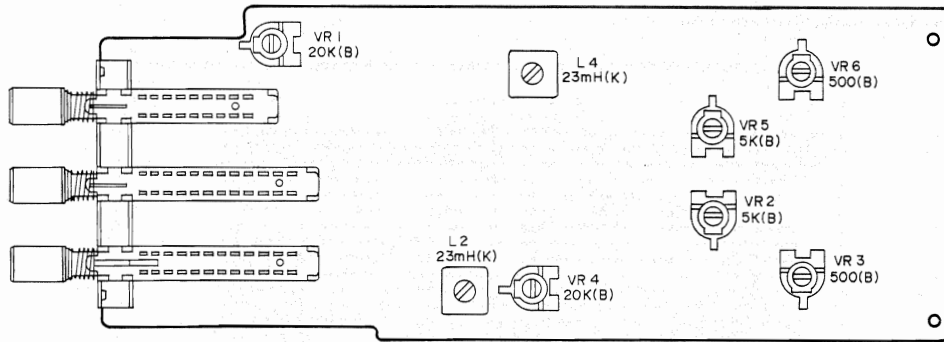

Fig. 3 DOLBY N.R. P.C. BOARD A5-5046 (face side)

DOLBY N.R. ADJUSTMENT

Adjustment Item	Adjustment Point	Reference Diagram	Remarks
19 KHz filter Adjustment	L2 (left channel), L4 (right channel) 23 mH	Figs. 1, 3	Adjust level of 19 KHz signal supplied to "Aux" to minimum.
REC. Mode Adjustment	VR3 (left channel), VR6 (right channel) 500 (B)	Figs. 1,2,3	With both semi-fixed volumes at maximum, ground T.P. and supply a 5 KHz signal to "AUX" and set output to -28.5 dB. Set Dolby SW. to ON and adjust for a 10 dB output increase.
	VR2 (left channel), VR5 (right channel) 5k (B)	Figs. 1,2,3	Disconnect T.P. from ground and adjust output to -20.5 dB.
Dolby Tone Level Adjustment	VR1 20k(B)	Fig. 3	Adjust to obtain right channel level meter indication of 0 VU.
Level Meter Sensitivity Adjustment	VR4 20k(B)	Fig. 3	Adjust to obtain left channel level meter indication of 0 VU.

NOTE: For Dolby Noise Reduction System operating principles, please refer to GENERAL OPERATING PRINCIPLES AND ADJUSTMENTS FOR AKAI TAPE RECORDERS AND TUNER AMPLIFIERS.

4. MAIN AMP. ADJUSTMENT

(1) IDLING CURRENT ADJUSTMENT

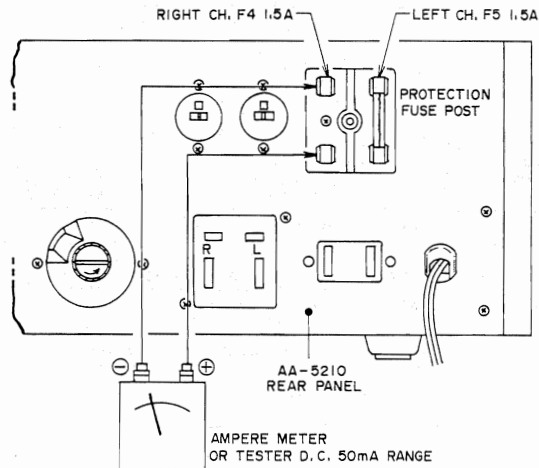

Fig. 4

(2) D.C. BALANCE ADJUSTMENT

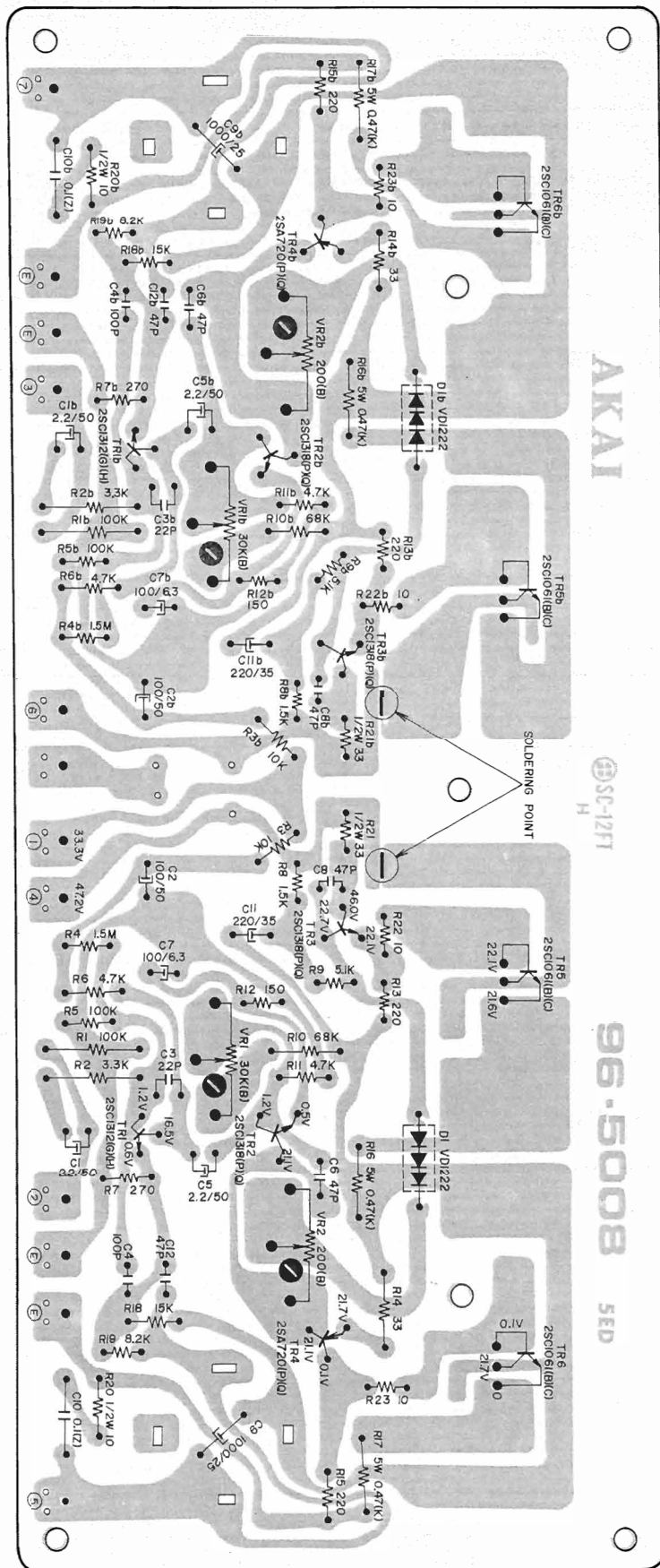

Fig. 5 MAIN AMP. P.C. BOARD 96-5008 (reverse side)

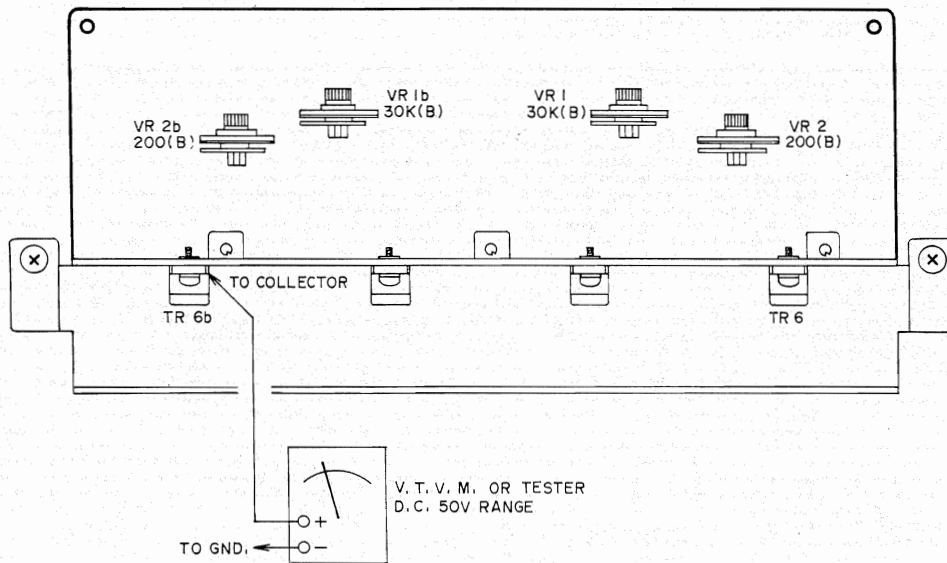

Fig. 6 MAIN AMP. P.C. BOARD 96-5008 (face side)

MAIN AMPLIFIER ADJUSTMENT

Adjustment Item	Adjustment Point	Reference Diagram	Remarks
IDLING CURRENT ADJUSTMENT	VR2, 2b 200(B)	Fig. 4	Adjust so that idling current is 25 to 30 mA.
D.C. BALANCE ADJUSTMENT	VR1, 1b 30k(B)	Figs. 5, 6	Adjust so that measured voltage is 1/2 the value of supply voltage.

IV. COMPOSITE VIEWS OF COMPONENTS

1. TONE CONTROL P.C. BOARD A5-5029

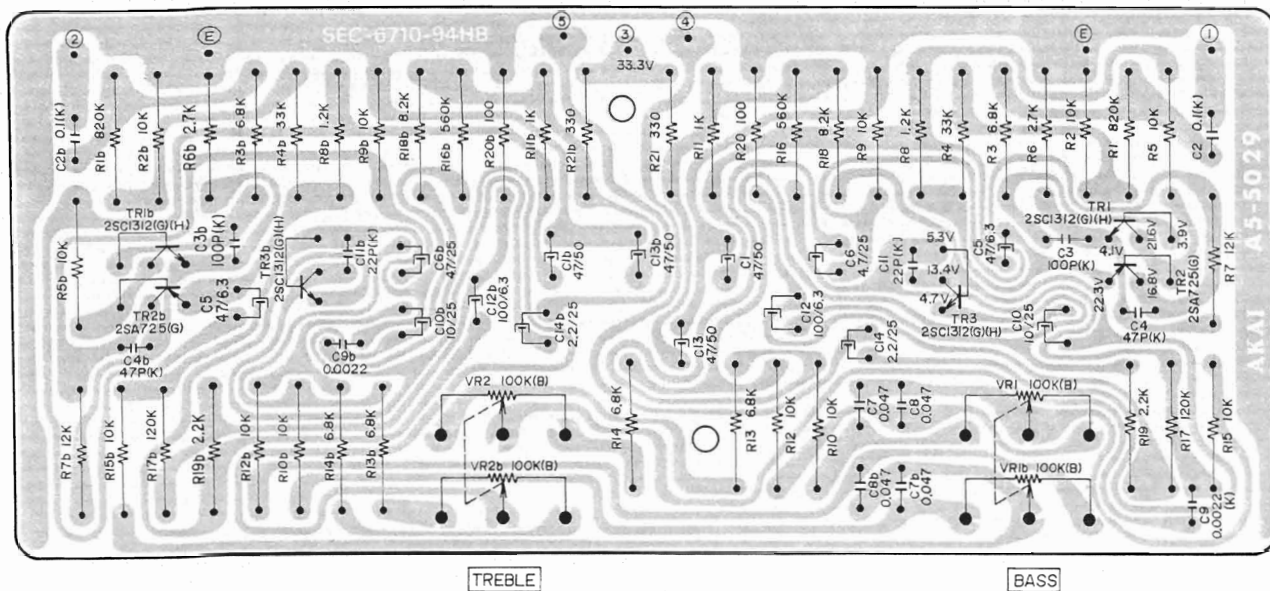

2. EQUALIZER P.C. BOARD A5-5028

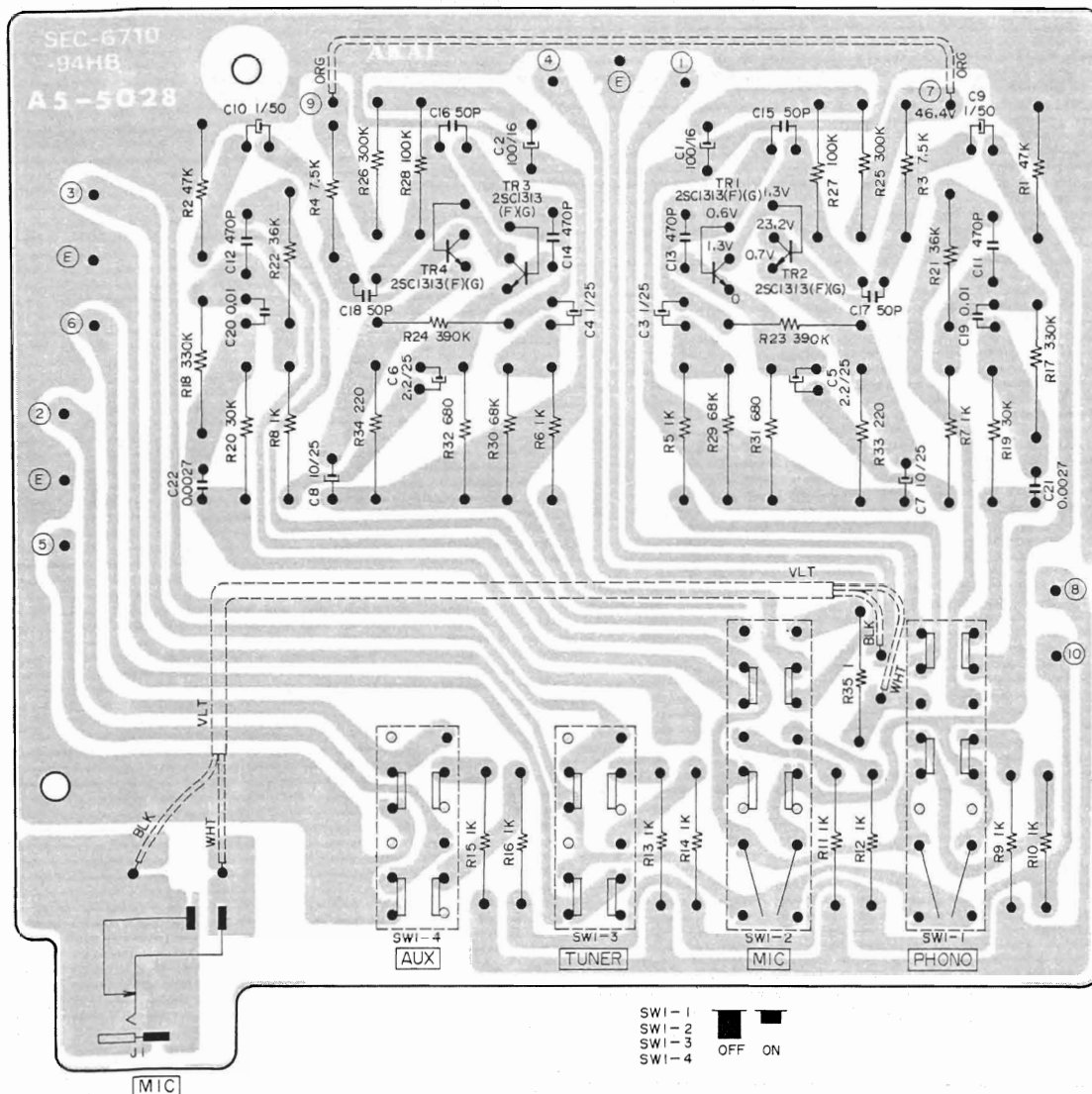

3. EQUALIZER P.C. BOARD A5-5083

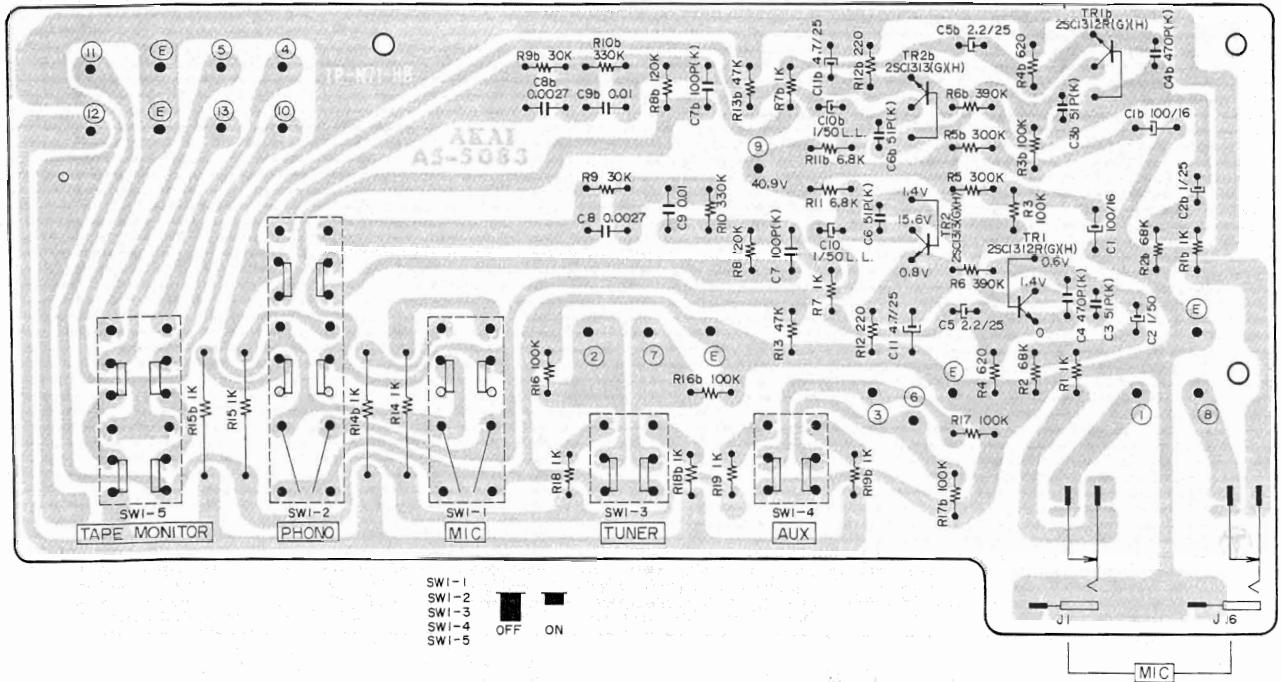

4. POWER SUPPLY P.C. BOARD A5-5047

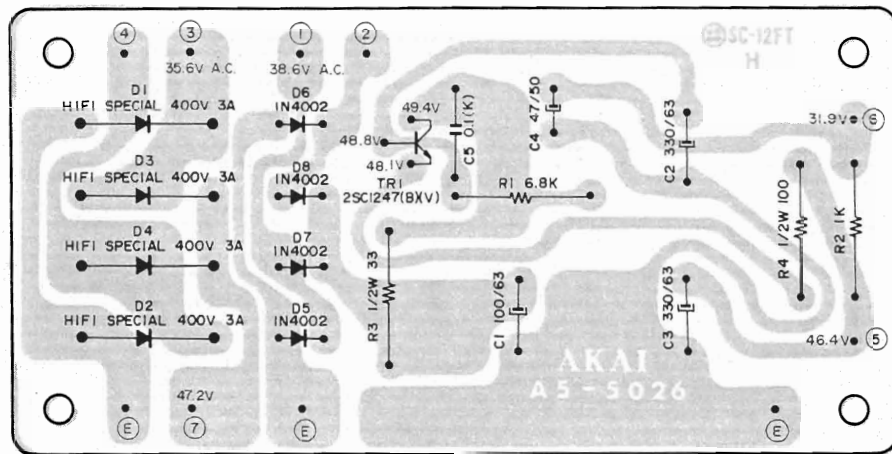

5. POWER SUPPLY P.C. BOARD A5-5047 (DB)

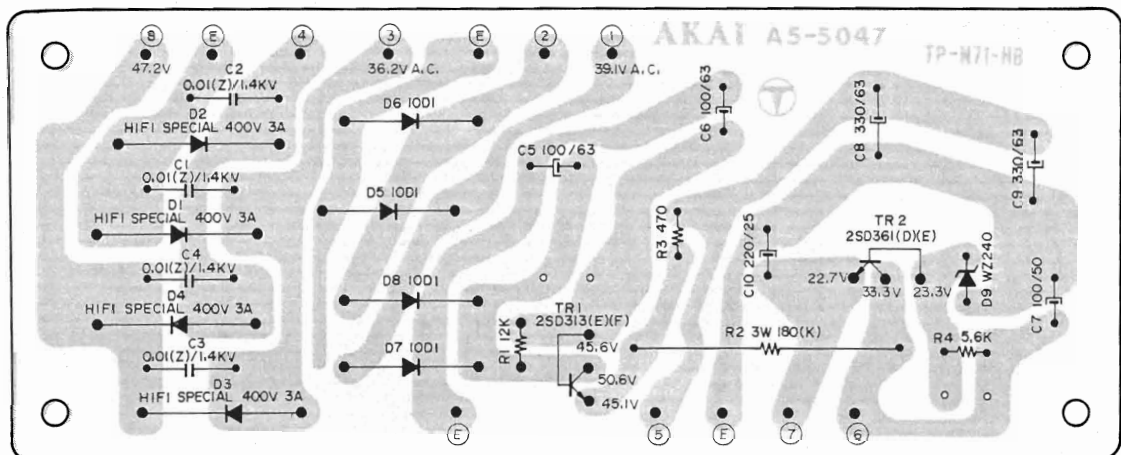

6. SW. P.C. BOARD A5-5061

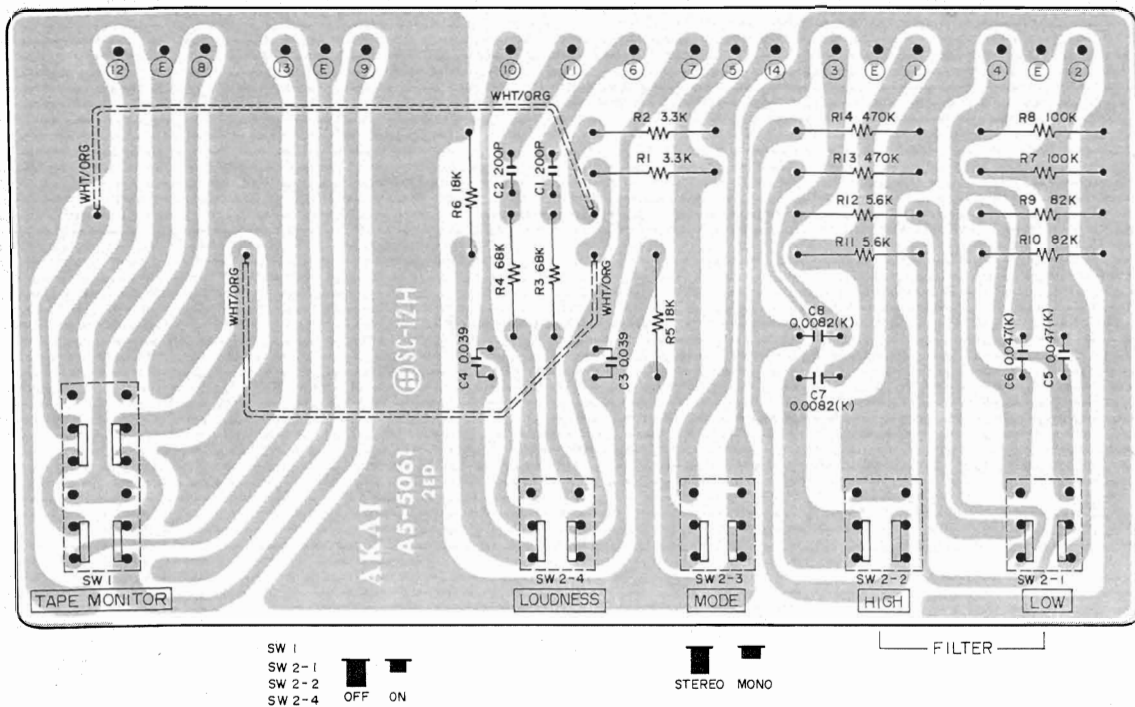

7. SW. P.C. BOARD A5-5061 (DB)

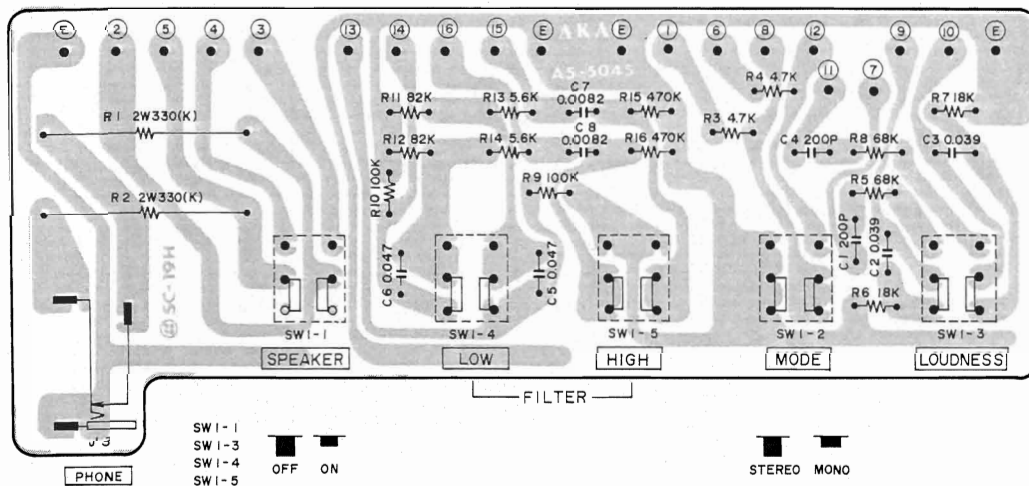

8. SPEAKER SW. P.C. BOARD A5-5027

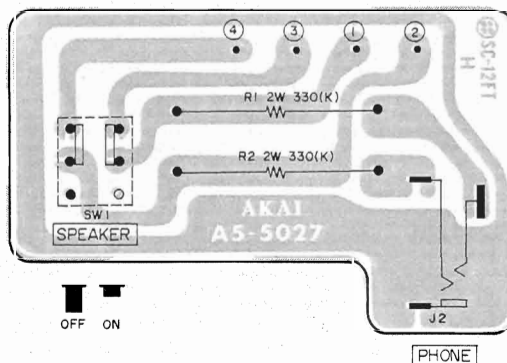

SECTION 2

PARTS LIST

TABLE OF CONTENTS

Fig. 1	MAIN AMP. P.C. BOARD (96-5008) BLOCK	16
Fig. 2	TONE CONTROL P.C. BOARD (A5-5029) BLOCK	17
Fig. 3	EQ. P.C. BOARD (A5-5028) BLOCK	18
Fig. 4	EQ. P.C. BOARD (A5-5083) BLOCK	19
Fig. 5	POWER SUPPLY P.C. BOARD (A5-5026) BLOCK	20
Fig. 6	POWER SUPPLY P.C. BOARD (A5-5047) BLOCK	20
Fig. 7	SW. P.C. BOARD (A5-5061) BLOCK	21
Fig. 8	SW. P.C. BOARD (A5-5045) BLOCK	21
Fig. 9	SPEAKER SW. P.C. BOARD (A5-5027) BLOCK	22
Fig. 10	DOLBY P.C. BOARD (A5-5046) BLOCK	22
Fig. 11	ASSEMBLY BLOCK	24
Fig. 12	FINAL ASSEMBLY BLOCK	26
INDEX	27

HOW TO USE THIS PARTS LIST

1. This parts list is compiled by various individual blocks based on assembly process.
2. When ordering parts, please describe parts number, serial number, and model number in detail.
3. How to read list.

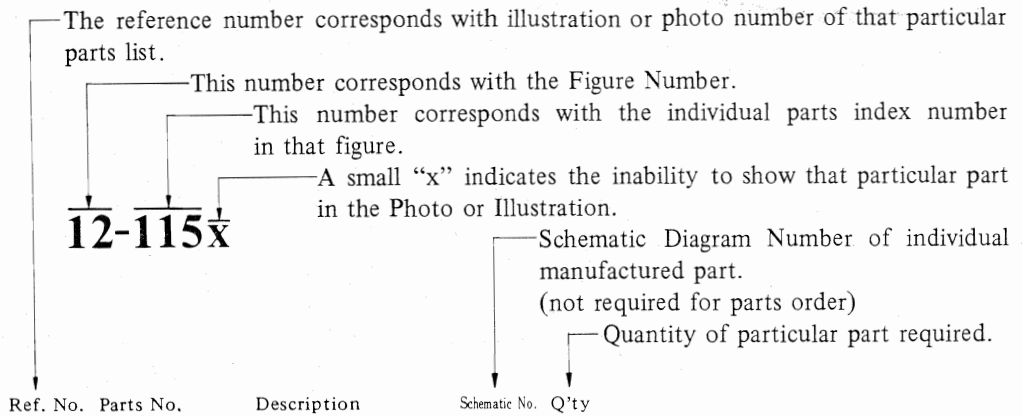

12-115x

Ref. No.	Parts No.	Description	Schematic No.	Q'ty
FLYWHEEL BLOCK #13				
12-115x	800425	Flywheel Block Assy. Comp.	RDG #13	1
12-116	244506	Flywheel Only	RD-233	1
12-117x	244754	Felt, Flywheel	RD-275	1
12-118	251324	Main Metal Case	RD-236	1
12-119	253080	Main Metal	RD-237	1

4. The symbol numbers shown on the P.C. Board list can be matched with the Composite Views of components of the Schematic Diagram or Service Manual.
5. The indications of Resistors and Capacitors in the photos of P.C. Board are being eliminated.
6. The shape of the parts and parts name, etc. can be confirmed by comparing them with the parts shown on the Electrical Parts Table of P.C. Board.
7. Please utilize separate "Common List for Service Parts" for Resistor parts orders.
8. Both the kind of part and installation position can be determined by the Parts Number. To determine where a parts number is listed, utilize Parts Index at end of Parts List.
It is necessary first of all to find the Parts Number. This can be accomplished by using the Reference Number listed at right of parts number in the Parts Index. (meaning of ref. no. outlined in Item 3 above).
9. Utilize separate "Price List for Parts" to determine unit price. The most simple method of finding parts Price is to utilize the reference number.

ELECTRICAL PARTS TABLE

<p>Because the indication of resistors and capacitors in the P. C. Board photos are being eliminated, please confirm parts name and shape by comparing them with the parts shown in this table.</p>	<p style="text-align: center;">1</p>  <p style="text-align: center;">Solid Resistor</p>	<p style="text-align: center;">2</p> <p style="text-align: right;">Stopper Type</p>  <p style="text-align: center;">Insulator Type</p> <p style="text-align: center;">Carbon Resistor</p>	<p style="text-align: center;">3</p>  <p style="text-align: center;">Metal Oxide Film Resistor</p>
<p style="text-align: center;">4</p>  <p style="text-align: center;">Cement Resistor</p>	<p style="text-align: center;">5</p>  <p style="text-align: center;">Wire-Wound Resistor</p>	<p style="text-align: center;">6</p>  <p style="text-align: center;">Thermister</p>	<p style="text-align: center;">7</p>  <p style="text-align: center;">Enamel Resistor</p>
<p style="text-align: center;">1</p>  <p style="text-align: center;">MP Capacitor (Tubular Type)</p>	<p style="text-align: center;">2</p>  <p style="text-align: center;">Plastic Capacitor</p>	<p style="text-align: center;">3</p>  <p style="text-align: center;">Mylar Capacitor</p>	<p style="text-align: center;">4</p>  <p style="text-align: center;">VFM (Hi-Q) Capacitor</p>
<p style="text-align: center;">5</p>  <p style="text-align: center;">Mylar Capacitor</p>	<p style="text-align: center;">6</p>  <p style="text-align: center;">Tantalum Capacitor</p>	<p style="text-align: center;">7</p>  <p style="text-align: center;">Oil Capacitor (Tubular Type)</p>	<p style="text-align: center;">8</p> <p style="text-align: right;">Vertical Type</p> <p>(Tubular Type)</p>  <p style="text-align: center;">Styrol Capacitor</p>
<p style="text-align: center;">9</p>  <p style="text-align: center;">Electrolytic Capacitor (Tubular Type)</p>	<p style="text-align: center;">10</p> <p style="text-align: right;">Vertical Type</p> <p>(Tubular Type)</p>  <p style="text-align: center;">Electrolytic Capacitor</p>	<p style="text-align: center;">11</p>  <p style="text-align: center;">Ceramic Capacitor</p>	<p style="text-align: center;">12</p>  <p style="text-align: center;">Metalized Mylar (Paper) Capacitor</p>
<p style="text-align: center;">13</p>  <p style="text-align: center;">Trimmer Condenser</p>		<p style="text-align: center;">VR</p>  <p style="text-align: center;">Semi-Fixed Volume</p>	
<p style="text-align: center;">L</p>  <p style="text-align: center;">Ferri Inductor</p>	<p style="text-align: center;">TR</p>  <p style="text-align: center;">Transistor</p>		
<p style="text-align: center;">CR</p>  <p style="text-align: center;">Spark Quencher</p>	<p style="text-align: center;">D</p>  <p style="text-align: center;">Diode (Silicon, Zener, Germanium)</p>		

FIG. 1 PHOTO OF MAIN AMP. P.C. BOARD (96-5008) BLOCK

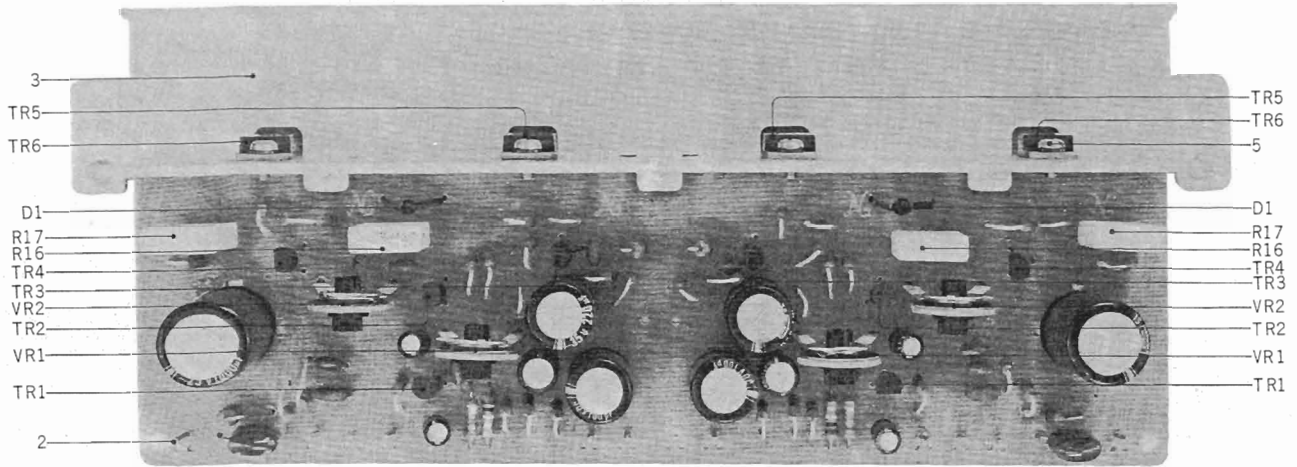

MAIN AMP. P.C. BOARD (96-5008) BLOCK

Symbol No.	Parts No.	Description	Q'ty
1-1x	BA602752	Main Amp. P.C. Board Comp. (96-5008)	1
1-TR1	ET516263	Transistor 2SC1312(G)(H)	2
1-TR2,3	ET562858	Transistor 2SC1318(P)(Q)	4
1-TR4	ET562860	Transistor 2SA720(P)(Q)	2
1-TR5,6	ET375603	Transistor 2SC1061(B)(C)	4
1-D1	ED490511	Varistor VD1222	2
1-VR1	EV383398	Semi-fixed/Vol. V18K3-2 30 kB (4 US)	2
1-VR2	EV221815	Semi-fixed/Vol. V18K3-2 200B (4 US)	2
1-2	EJ539662	Wrapping Post 1x17	11
1-3	EZ605957	Heat-sink	1
1-4	EZ602403	Insulator Washer YN27B	4
1-5	ZS379350	ISO Screw, Pan Head 3x6	4
1-6	ZS325495	Tapping Screw #2 3x6	3
1-R16,17	ER622978	Metal Plate/R.	4
Capacitor, Vertical Type			
1-C1	EC354947	Elect. 2.2 μ F 50WV	2
1-C2	EC321221	Elect. 100 μ F 50WV	4
1-C3	EC399565	VFM 22PF(J) 50WV	2
1-C4	EC290520	VFM 100PF(J) 50WV	2
1-C5	EC354947	Elect. 2.2 μ F 50WV	2
1-C6	EC377212	VFM 47PF(J) 50WV	2
1-C7	EC336104	Elect. 100 μ F 6.3WV	2
1-C8	EC377212	VFM 47PF(J) 50WV	2
1-C9	EC450270	Elect. 1000 μ F 25WV	2
1-C10	EC398957	Mylar 0.1 μ F(M) 50WV	2
1-C11	EC372148	Elect. 220 μ F 35WV	2
1-C12	EC377212	VFM 47PF(J) 50WV	2
Carbon Resistor Omitted			

FIG. 2 PHOTO OF TONE CONTROL P.C. BOARD (A5-5029) BLOCK

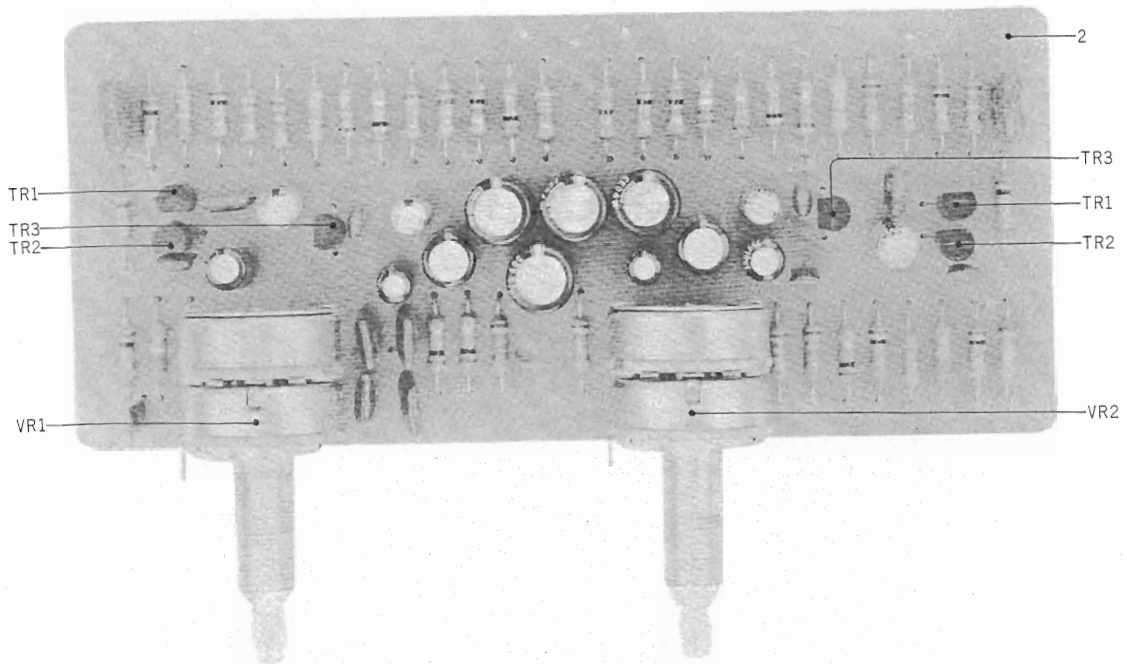

**TONE CONTROL P.C. BOARD
(A5-5029) BLOCK**

Symbol No.	Parts No.	Description	Q'ty
2-1x	BA602807	Tone Control P.C. Board Comp. (A5-5029)	1
2-TR1	ET517263	Transistor 2SC1312(G)(H)	2
2-TR2	ET555952	Transistor 2SA725(G)	2
2-TR3	ET517263	Transistor 2SC1312(G)(H)	2
2-VR1,2	EV602458	Co-axial 2-Throw Vol.(w/click) V24L5GPHN 1kB 100kx2	2
2-2	EJ539662	Wrapping Post 1x17	7
Capacitor, Vertical Type			
2-C1	EC346735	Elect. 47 μ F 50WV	2
2-C2	EC251291	Mylar 0.1 μ F(K) 50WV	2
2-C3	EC290531	VFM 100PF(K) 50WV	2
2-C4	EC487394	VFM 47PF(K) 50WV	2
2-C5	EC329771	Elect. 47 μ F 6.3WV	2
2-C6	EC450527	Elect. 4.7 μ F 25WV	2
2-C7, 8	EC379214	Mylar 0.047 μ F(J) 50WV	4
2-C9	EC250716	Mylar 0.0022 μ F(K) 50WV	2
2-C10	EC220994	Elect. 10 μ F 25WV	2
2-C11	EC556525	FM 22PF(K) 500WV	2
2-C12	EC336104	Elect. 100 μ F 6.3WV	2
2-C13	EC346735	Elect. 47 μ F 50WV	2
2-C14	EC220432	Elect. 2.2 μ F 25WV	2
Carbon Resistor Omitted			

FIG. 3 PHOTO OF EQ. P.C. BOARD (A5-5028) BLOCK

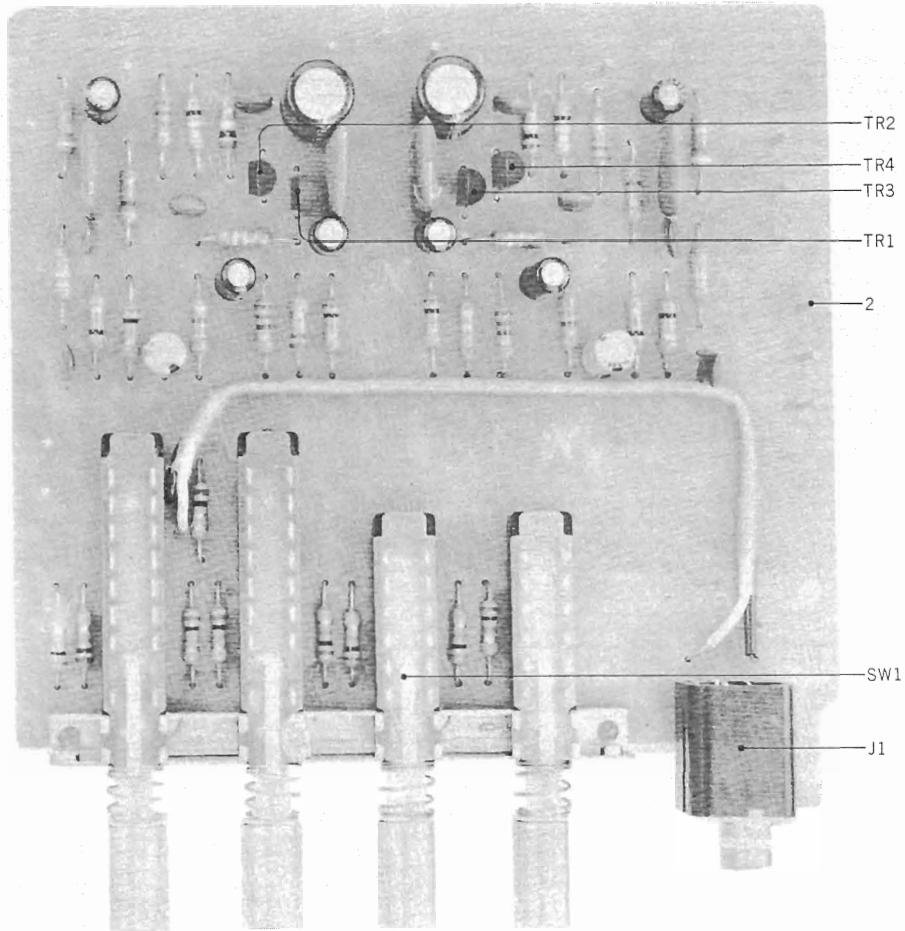

EQ. P.C. BOARD (A5-5028) BLOCK

Symbol No.	Parts No.	Description	Q'ty
3-1x	BA602818	EQ. P.C. Board Comp. (A5-5028)	1
3-TR1to4	ET602460	Transistor 2SC1313(F)(G)(H)	4
3-J1	EJ391094	Mic. Jack 2PMJ1P	1
3-SW1	ES628626	Push SW. 4FTM-0001FF-9920	1
3-2	EJ539662	Wrapping Post 1x17	13
Capacitor, Vertical Type			
3-C1,2	EC220127	Elect. 100 μ F 16WV	2
3-C3,4	EC450055	Elect. 1 μ F 25WV	2
3-C5,6	EC220432	Elect. 2.2 μ F 25WV	2
3-C7,8	EC220994	Elect. 10 μ F 25WV	2
3-C9,10	EC313108	Elect. 1 μ F 50WV	2
3-C11to14	EC423562	VFM 470PF(J) 50WV	4
3-C15to18	EC350616	VFM 50PF(J) 50WV	4
3-C19,20	EC302321	Mylar 0.01 μ F(J) 50WV	2
3-C21,22	EC379765	Mylar 0.002 μ F(J) 50WV	2
		Carbon Resistor Omitted	

FIG. 4 PHOTO OF EQ. P.C. BOARD (A5-5083) BLOCK

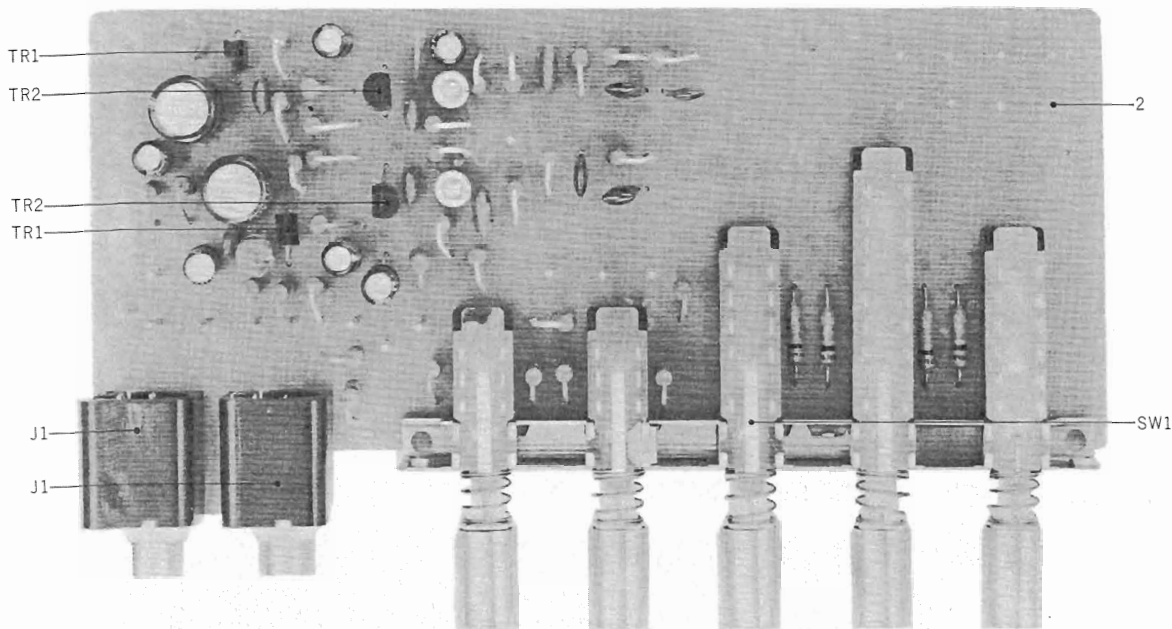

EQ. P.C. BOARD (A5-5083) BLOCK

Symbol No.	Parts No.	Description	Q'ty
4-1x	BA604258	EQ. P.C. Board Comp. (A5-5083) (DB)	1
4-TR1	ET517263	Transistor 2SC1312(G)(H)	2
4-TR2	ET604124	Transistor 2SC1313(G)(H)	2
4-SW1	ES628648	Push SW. 5FTM-0001FF-9920	1
4-J1	EJ391094	Mic. Jack 2PMJ1P	2
4-2	EJ539662	Wrapping Post 1x17	18
Capacitor, Vertical Type			
4-C1	EC220127	Elect. 100 μ F 16WV	2
4-C2	EC450055	Elect. 1 μ F 25WV	2
4-C3	EC556075	VFM 51PF(K) 50WV	2
4-C4	EC516767	Styrol 470PF(K) 50WV	2
4-C5	EC220432	Elect. 2.2 μ F 25WV	2
4-C6	EC556075	VFM 51PF(K) 50WV	2
4-C7	EC290531	VFM 100PF(K) 50WV	2
4-C8	EC379765	Mylar 0.0027 μ F(J) 50WV	2
4-C9	EC250841	Mylar 0.01 μ F(J) 50WV	2
4-C10	EC479621	Elect. 1 μ F 50WV NL	2
4-C11	EC450527	Elect. 4.7 μ F 25WV	2
Carbon Resistor Omitted			

FIG. 5 PHOTO OF POWER SUPPLY P.C. BOARD (A5-5026) BLOCK

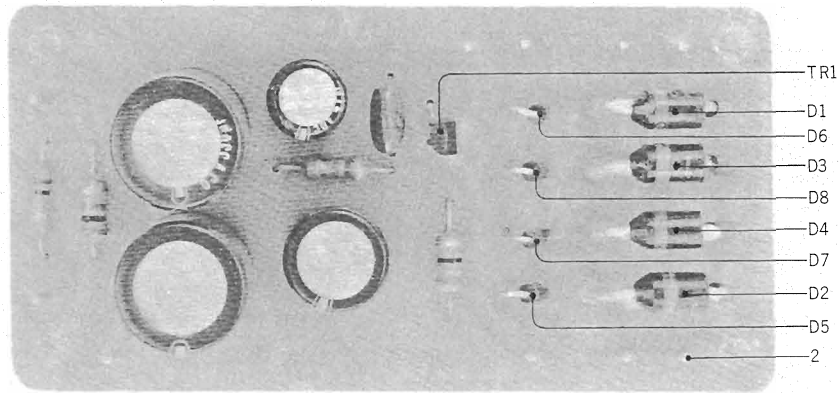
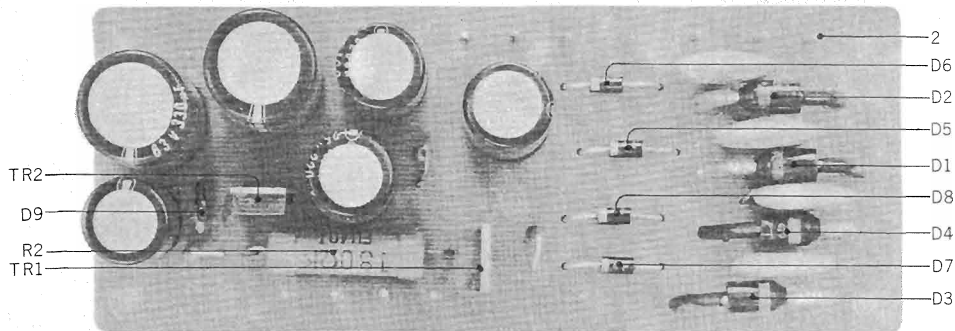

FIG. 6 PHOTO OF POWER SUPPLY P.C. BOARD (A5-5047) BLOCK



**POWER SUPPLY P.C. BOARD
(A5-5026) BLOCK**

Symbol No.	Parts No.	Description	Q'ty
5-1x	BA602763	Power Supply P.C. Board Comp. (A5-5026)	1
5-TR1	ET511920	Transistor 2SC1247(B)(V)	1
5-D1to4	ED558033	Silicon Diode HIFI 400V 3A (Special)	4
5-D5to8	ED511907	Silicon Diode 1N4002	4
5-2	EJ539662	Wrapping Post 1x17	10
		Capacitor, Vertical Type	
5-C1	EC349604	Elect. 100 μ F 63WV	1
5-C2, 3	EC603112	Elect. 330 μ F 63WV	2
5-C4	EC346735	Elect. 47 μ F 50WV	1
5-C5	EC251291	Mylar 0.1 μ F(K) 50WV Carbon Resistor Omitted	1

**POWER SUPPLY P.C. BOARD
(A5-5047) BLOCK**

Symbol No.	Parts No.	Description	Q'ty
6-1x	BA604225	Power Supply P.C. Board Comp. (A5-5047) (DB)	1
6-TR1	ET452531	Transistor 2SD313(E)(F)	1
6-TR2	ET537300	Transistor 2SD361(D) (E)	1
6-D1to4	ED558033	Silicon Diode HIFI 400V 3A(Special)	4
6-D5to8	ED224526	Silicon Diode 10D1	4
6-D9	ED511918	Zener Diode WZ-240	1
6-2	EJ539662	Wrapping Post 1x17	16
6-R2	ER604078	Metal Oxide FILM/R. 3W 180 Ω (K)	1
		Capacitor, Vertical Type	
6-C1to4	EC551160	Ceramic NB821 YZ 0.01 μ F(Z) 1.4WV	4
6-C5, 6	EC349604	Elect. 100 μ F 63WV	2
6-C7	EC321221	Elect. 100 μ F 50WV	1
6-C8, 9	EC603112	Elect. 330 μ F 63WV	2
6-C10	EC336115	Elect. 220 μ F 25WV Carbon Resistor Omitted	1

FIG. 7 PHOTO OF SW. P.C. BOARD (A5-5061) BLOCK

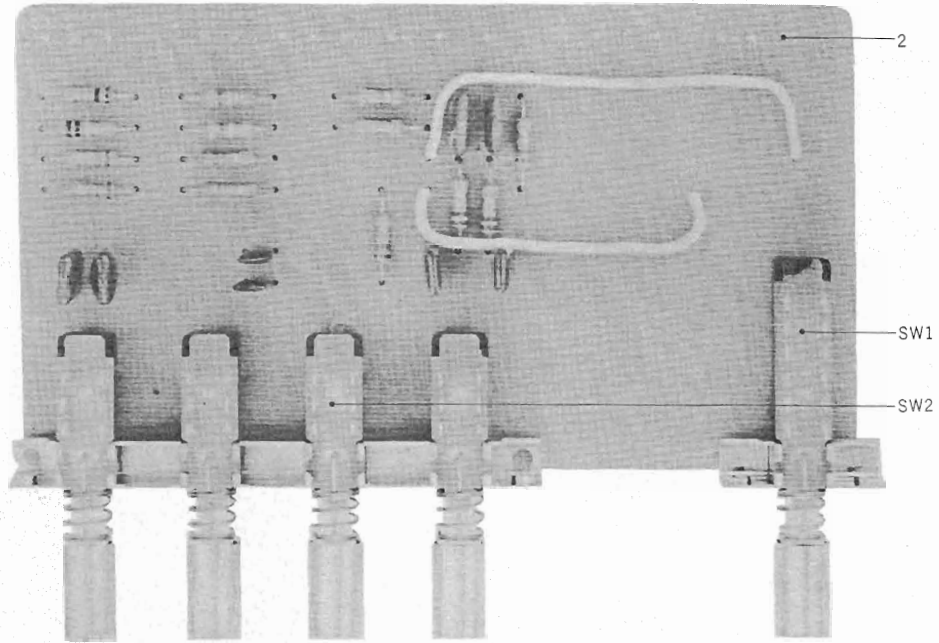
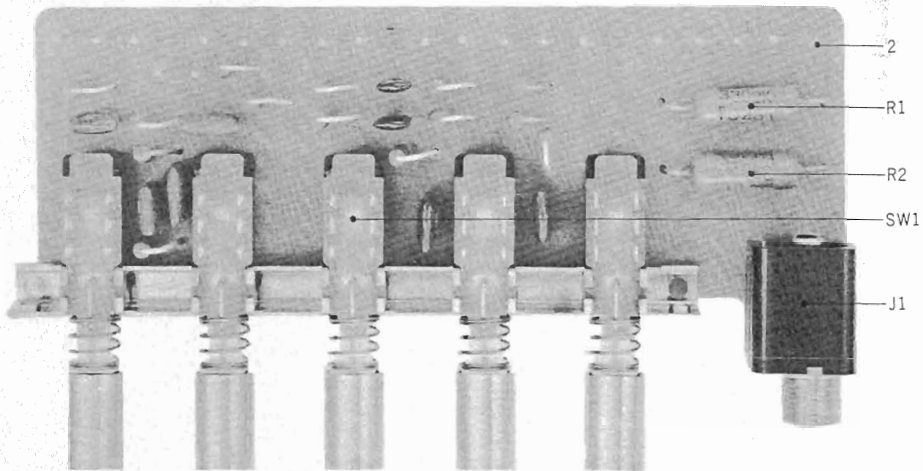

FIG. 8 PHOTO OF SW. P.C. BOARD (A5-5045) BLOCK



SW. P.C. BOARD (A5-5061) BLOCK

Symbol No.	Parts No.	Description	Q'ty
7-1x	BA602831	SW. P.C. Board Comp. (A5-5061)	1
7-SW1	ES562781	Push SW. 1FS-4U-8	1
7-SW2	ES628560	Push SW. 4FT-0007FF-1320	1
7-2	EJ539662	Wrapping Post 1x17	18
Capacitor, Vertical Type			
7-C1, 2	EC389237	VFM 200PF(J) 50WV	2
7-C3, 4	EC379192	Mylar 0.039μF(J) 50WV	2
7-C5, 6	EC308711	Mylar 0.047μF(K) 50WV	2
7-C7, 8	EC379833	Mylar 0.0082μF(K) 50WV	2
Carbon Resistor Omitted			

SW. P.C. BOARD (A5-5045) BLOCK

Symbol No.	Parts No.	Description	Q'ty
8-1x	BA604260	SW. P.C. Board Comp. (A5-5045) (DB)	1
8-SW1	ES628650	Push SW. 5FT-0004FF-2020	1
8-J1	EJ391083	Mic. Jack 3PMJ1P	1
8-2	EJ539662	Wrapping Post 1x17	18
8-R1, 2	ER517094	Metal Oxide Film/R. 2W 330Ω(K)	2
Capacitor, Vertical Type			
8-C1	EC389237	VFM 200PF(J) 50WV	1
8-C2, 3	EC379192	Mylar 0.039μF(J) 50WV	2
8-C4	EC389237	VFM 200PF(J) 50WV	1
8-C5, 6	EC379124	Mylar 0.047μF(J) 50WV	2
8-C7, 8	EC411827	Mylar 0.0082μF(J) 50WV	2
Carbon Resistor Omitted			

FIG. 9 PHOTO OF SPEAKER SW.
P.C. BOARD (A5-5027) BLOCK

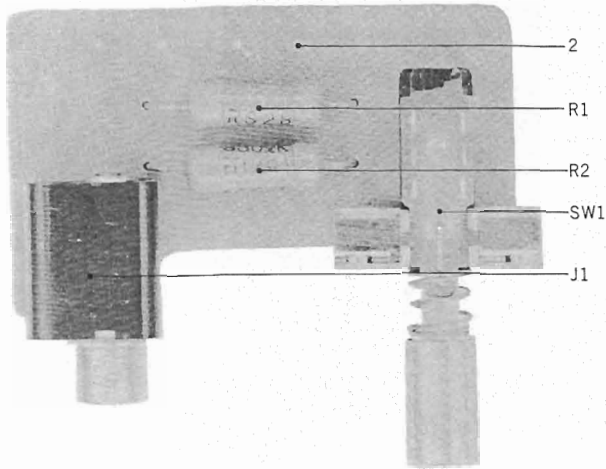

SPEAKER SW. P.C. BOARD
(A5-5027) BLOCK

Symbol No.	Parts No.	Description	Q'ty
9-1x	BA602820	Speaker SW. P.C. Board Comp. (A5-5027)	1
9-J1	EJ391083	Mic. Jack 3PMJ1P	1
9-SW1	ES551171	Push SW. 1FS-2U-12	1
9-2	EJ539662	Wrapping Post 1x17	4
9-R1, 2	ER559034	Metal Oxide Film/R. 2W 330Ω(K)	2

FIG. 10 PHOTO OF DOLBY P.C. BOARD
(A5-5046) BLOCK

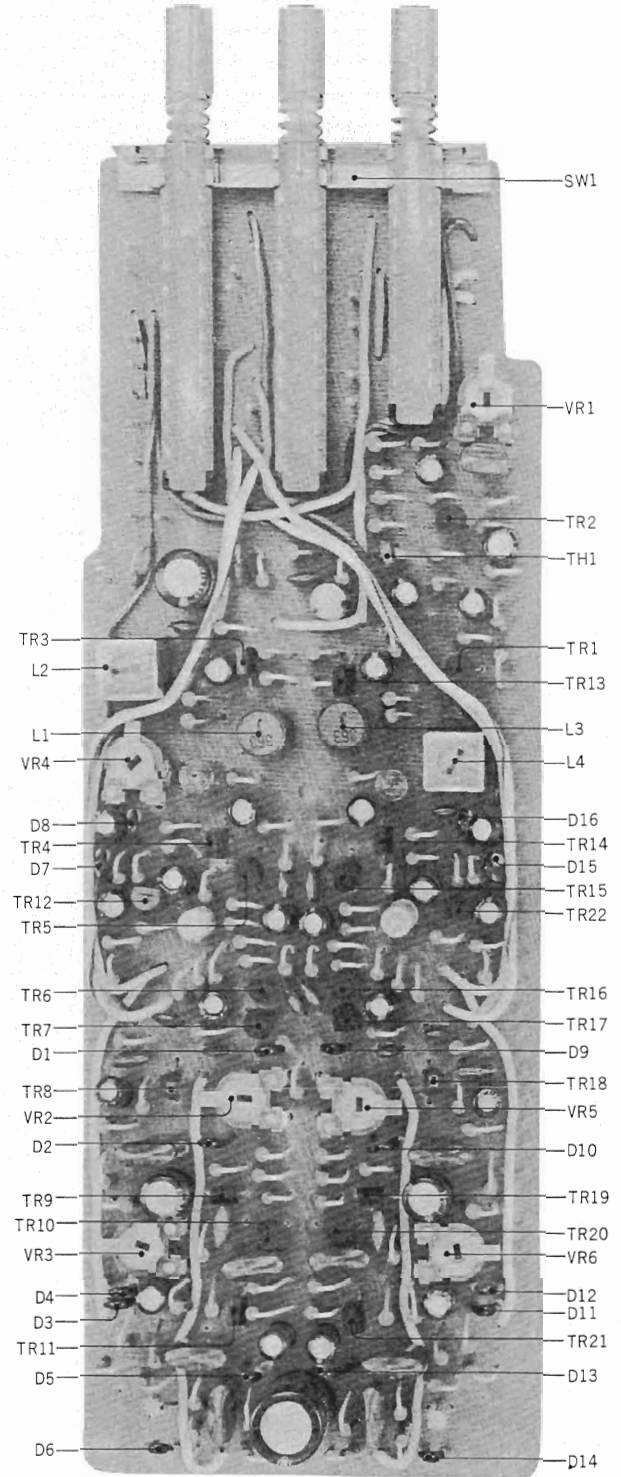

DOLBY P.C. BOARD (A5-5046) BLOCK

Symbol No.	Parts No.	Description	Q'ty	Symbol No.	Parts No.	Description	Q'ty
10-1x	BA 604247	Dolby P.C. Board Comp. (A5-5046)	1	10-C26	EC251291	Mylar 0.1 μ F(K) 50WV	1
10-TR1, 2	ET 520841	Transistor 2SC711(E)(F)(G)	2	10-C27	EC320040	Elect. 47 μ F 16WV	1
10-TR3, 4	ET 517263	Transistor 2SC1312(G) (H)	2	10-C28	EC290531	VFM 100PF(K) 50WV	1
10-TR5	ET 557976	Transistor 2SA628(E)(F)	1	10-C29	EC320051	Elect. 10 μ F 16WV	1
10-TR6	ET 517263	Transistor 2SC1312(G)(H)	1	10-C30	EC251291	Mylar 0.1 μ F(K) 50WV	1
10-TR7	ET 520841	Transistor 2SC711(E)(F) (G)	1	10-C31	EC320051	Elect. 10 μ F 16WV	1
10-TR8	ET 491051	FET 2SK30A(GR)	1	10-C32, 33	EC251291	Mylar 0.1 μ F(K) 50WV	2
10-TR9	ET 517263	Transistor 2SC1312(G)(H)	1	10-C34	EC604440	Solid Aluminum 0.33 μ F(M) 25WV	1
10-TR10	ET 557976	Transistor 2SA628(E)(F)	1	10-C35to37	EC320051	Elect. 10 μ F 16WV	3
10-TR11,12	ET 520841	Transistor 2SC711(E)(F)(G)	2	10-C38	EC357232	Mylar 0.0039 μ F(K) 50WV	1
10-TR13,14	ET 517263	Transistor 2SC1312(G)(H)	2	10-C39	EC495865	Styrol 3000PF(J) 50WV	1
10-TR15	ET 557976	Transistor 2SA628(E)(F)	1	10-C40	EC250716	Mylar 0.0022 μ F(K) 50WV	1
10-TR16	ET 517263	Transistor 2SC1312(G)(H)	1	10-C41	EC450055	Elect. 1 μ F 25WV	1
10-TR17	ET 520841	Transistor 2SC711(E)(F)(G)	1	10-C42	EC357827	VFM 50PF(K) 50WV	1
10-TR18	ET 491051	FET 2SK30A(GR)	1	10-C43	EC320051	Elect. 10 μ F 16WV	1
10-TR19	ET 517263	Transistor 2SC1312(G)(H)	1	10-C44	EC432810	Elect. 10 μ F 16WV NL	1
10-TR20	ET 557976	Transistor 2SA628(E) (F)	1	10-C45	EC320051	Elect. 10 μ F 16WV	1
10-TR21,22	ET 520841	Transistor 2SC711(E)(F)(G)	2	10-C46	EC556525	FM 22PF(K) 500WV	1
10-D1	ED219464	Germanium Diode 1N34A	1	10-C47	EC320051	Elect. 10 μ F 16WV	1
10-D2	ED491130	Zener Diode WZ-085	1	10-C48	EC362125	Mylar 0.0056 μ F(K) 50WV	1
10-D3, 4	ED560913	Silicon Diode 1S2473 VE	2	10-C49	EC251122	Mylar 0.027 μ F(K) 50WV	1
10-D5	ED219464	Germanium Diode 1N34A	1	10-C50	EC362158	Mylar 0.0047 μ F(K) 50WV	1
10-D6	ED560913	Silicon Diode 1S2473 VE	1	10-C51	EC320051	Elect. 10 μ F 16WV	1
10-D7,8,9	ED219464	Germanium Diode 1N34A	3	10-C52	EC251291	Mylar 0.1 μ F(K) 50WV	1
10-D10	ED491130	Zener Diode W Z-085	1	10-C53	EC320040	Elect. 47 μ F 16WV	1
10-D11,12	ED560913	Silicon Diode 1S2473 VE	2	10-C54	EC290531	VFM 100PF(K) 50WV	1
10-D13	ED219464	Germanium Diode 1N34A	1	10-C55	EC320051	Elect. 10 μ F 16WV	1
10-D14	ED560913	Silicon Diode 1S2473 VE	1	10-C56	EC251291	Mylar 0.1 μ F(K) 50WV	1
10-D15, 16	ED219464	Germanium Diode 1N34A	2	10-C57	EC320051	Elect. 10 μ F 16WV	1
10-VR1	EV560136	Semi-Fixed/Vol. V10K8-4-2 20k Ω	1	10-C58,59	EC251291	Mylar 0.1 μ F(K) 50WV	2
10-VR2	EV499364	Semi-Fixed/Vol. V10K8-4-2 5k Ω	1	10-C60	EC604440	Solid Aluminum 0.33 μ F(M) 25WV	1
10-VR3	EV484863	Semi-Fixed/Vol. V10K8-4-2 1k Ω (Metalized Film)	1	10-C61,62	EC320051	Elect. 10 μ F 16WV Carbon Resistor Omitted	2
10-VR4	EV560136	Semi-Fixed/Vol. V10K8-4-2 20k Ω	1				
10-VR5	EV499364	Semi-Fixed/Vol. V10K8-4-2 5k Ω	1				
10-VR6	EV484863	Semi-Fixed/Vol. V10K8-4-2 1k Ω (Metalized Film)	1				
10-L1	EO496350	Inductor 146LY 36MH(J)	1				
10-L2	EO496361	Inductor 6070GE 23MH(J)	1				
10-L3	EO496350	Inductor 146Y 36MH(J)	1				
10-L4	EO496361	Inductor 6070GE 23MH(J)	1				
10-SW1	ES628637	Push SW. 3FT-0008FF-2020	1				
10-TH1	ED485370	Thermister 24D26	1				
10-2	EJ539662	Wrapping Post 1x17	20				
Capacitor, Vertical Type							
10-C1	EC250841	Mylar 0.01 μ F(J) 50WV	1				
10-C2	EC379157	Mylar 0.03 μ F(J) 50WV	1				
10-C3	EC220994	Elect. 10 μ F 25WV	1				
10-C4, 5	EC320051	Elect. 10 μ F 16WV	2				
10-C6	EC331828	Elect. 3.3 μ F 25WV	1				
10-C7	EC331705	Elect. 22 μ F 16WV	1				
10-C8	EC302253	Mylar 0.15 μ F(K) 50WV	1				
10-C9	EC320051	Elect. 10 μ F 16WV	1				
10-C10	EC357232	Mylar 0.0039 μ F(K) 50WV	1				
10-C11	EC495865	Styrol 3000PF(J) 50WV	1				
10-C12	EC250716	Mylar 0.0022 μ F(K) 50WV	1				
10-C13	EC450055	Elect. 1 μ F 25WV	1				
10-C14	EC357827	VFM 50PF(K) 50WV	1				
10-C15	EC320051	Elect. 10 μ F 16WV	1				
10-C16	EC432810	Elect. 10 μ F 16WV NL	1				
10-C17	EC320051	Elect. 10 μ F 16WV	1				
10-C18	EC556525	FM 22PF(K) 500WV	1				
10-C19	EC320051	Elect. 10 μ F 16WV	1				
10-C20	EC336126	Elect. 47 μ F 25WV	1				
10-C21	EC336115	Elect. 220 μ F 25WV	1				
10-C22	EC362125	Mylar 0.0056 μ F(K) 50WV	1				
10-C23	EC251122	Mylar 0.027 μ F(K) 50WV	1				
10-C24	EC362158	Mylar 0.0047 μ F(K) 50WV	1				
10-C25	EC320051	Elect. 10 μ F 16WV	1				

When ordering parts, please describe Parts Number, Serial Number, and Model Number in detail.

Dolby is a trademark of Dolby Laboratories, Inc. Under License from Dolby Laboratories, Inc.

FIG. 11 PHOTO OF ASSEMBLY BLOCK

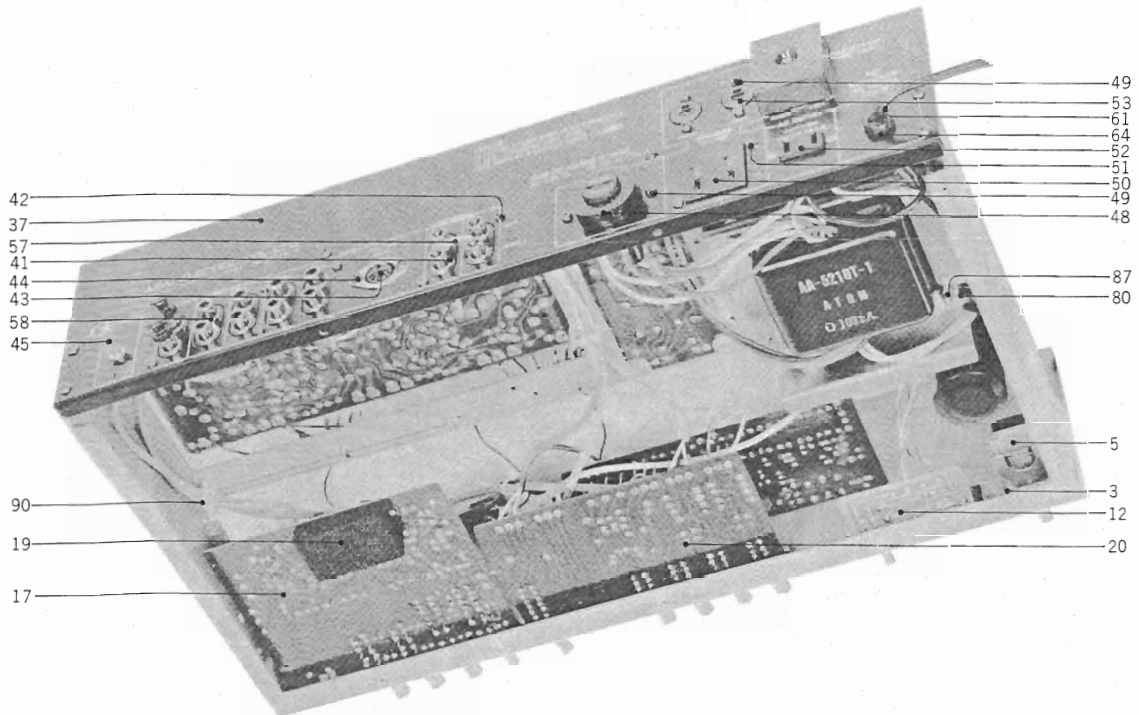
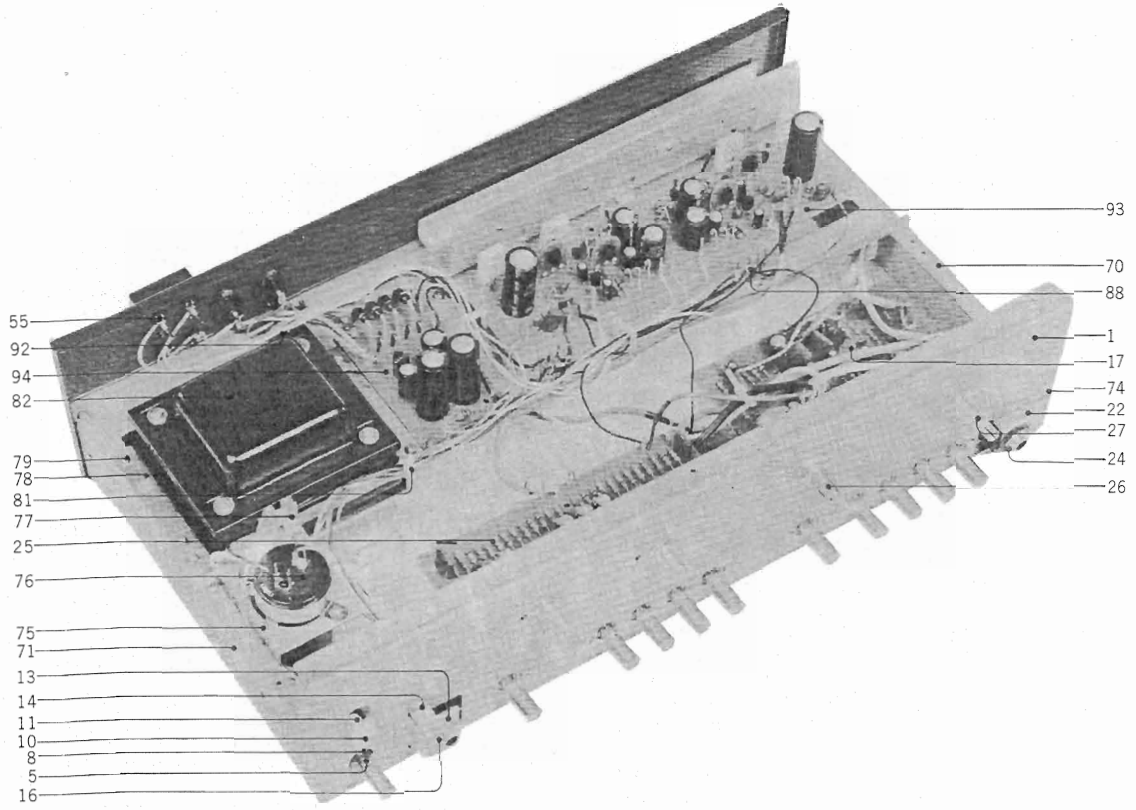

ASSEMBLY BLOCK

Ref. No.	Parts No.	Description	Schematic No.	Q'ty	Ref. No.	Parts No.	Description	Schematic No.	Q'ty
		FRONT CHASSIS BLOCK			11-50	EJ551316	Speaker Consent Assy. P0409	31-1-98	1
11-1	TA605970	Front Chassis	A5-5008	1	11-51	ZS570385	ISO Screw, Pan Head 3x8		2
11-2x	TA604236	Front Chassis B(DB)	A5-5034	1	11-52	EJ378944	Socket, AC U/L S-1 9122	31-1-47	1
11-3	TA609761	SW. Angle	A5-5009	1	11-53	EJ602537	Connector Socket 2P	31-1-116	2
11-4x	TA609761	SW. Angle (EC)	A5-5009	1	11-54x	ZW516993	Nut M3		4
11-5	ES469541	Push SW. TV-3 JB52	25-5-60	1	11-55	EJ539796	2P Fuse Holder	40-1-29	1
11-6x	ES602594	Push SW. 250V 4A(EC)	25-5-147	1	11-56x	ZS463353	Tapping Screw #2 3x8(BR)		2
11-7x	EC551160	Cermic/C. NB821 YZ 0.01μF(Z) 1.4KWV	24-5-55	1	11-57	EJ554578	Short Plug	42-1-66	2
11-8	ZS422076	Screw, Pan Head 3x5		2	11-58	EJ551340	6P Wrapping Pin Jack B T-5347(B)	31-1-102	1
11-9x	TA606576	Power Insulator Paper (CSA,EC)	A5-5074	1	11-59x	ER452777	Carbon/R. (Insu. Type) RD1/4 160K(J)	35-9-5	2
11-10	EL458864	Pilot Lamp (L/T) 8V 80MA(150M/Mx2)	28-2-22	1	11-60x	ER364994	Carbon/R. (Insu. Type) RD1/4 39K(J)	35-9-5	2
11-11	TA510502	Lamp Holder	T5-5035	1	11-61	EW374894	U/L AC Cord 3M	26-3-19	1
11-12	BA602820	Speaker SW. P.C. Board Comp. AA-5210	A5-5027	1	11-62x	EW559260	Power Cord (EC) TYPE-412	26-3-33	1
11-13	TA609772	Jack MT. Table A	A5-5010	1	11-63x	EW315448	Australia Cord (3 Core)	26-3-11	1
11-14	ZS325495	Tapping Screw #2 3x6		2	11-64x	EZ382263	Strain Relief SR-4K-4	2-7-12	1
11-15x	ZW434597	Washer (ALP) D9.3x14.2x0.7T		1	11-65x	EZ246936	Strain Relief SR-6W-1 (WG. 3 Core)	2-7-8	1
11-16	ZW554624	E Jack Nut	7-1-56	2	11-66x	EF563703	Fuse 2A 250V	39-1-50	1
11-17	BA602818	EQ. SW. P.C. Board Comp. AA-5210	A5-5028	1	11-67x	ZW273881	Earth Lug M4 (3 Core)		1
11-18x	BA604258	EQ. P.C. Board Comp. AA-5210DB	A5-5083	1	11-68x	ZW413188	Nut M4 (3 Core)		1
11-19	EZ478675	Upper Cover Cushion	55-5053	1	11-69x	ZW273914	Spring Washer M4(3Core)		1
11-20	BA602831	SW. P.C. Board Comp. AA-5210	A5-5061	1			ASSEMBLY BLOCK		
11-21x	BA604260	SW. P.C. Board Comp. AA-5210DB	A5-5045	1	11-70	TA605924	Side Plate Metal Parts A (Right)	A5-5002	1
11-22	TA609783	Jack MT. Table B	A5-5011	1	11-71	TA606058	Side Plate Metal Parts B (Left)	A5-5002	1
11-23x	EZ225180	Nylon Collar, Jack	LD-520	1	11-72x	TA610446	Side Plate Metal Fitting D (Right) (DB)	A5-5031	1
11-24x	ZW260368	Washer (Fiber) D9.2x18x0.5T		1	11-73x	TA610132	Side Plate Metal Fitting C (Left) (DB)	A5-5031	1
11-25	BA602807	Tone Control P.C. Board Comp. AA-5210	A5-5029	1	11-74	ZS325495	Tapping Screw #2 3x6		20
11-26	EV602414	Co-axial 2-throw Vol. (W/Preset) V24L5DGM 2BM250K x 2	36-29-4	1	11-75	EZ594325	Condenser Retaining Plate	A5-5004	1
11-27	EV602425	Co-axial 2-throw Vol. V24L5GWTH 1Z500Kx2	36-1-33	1	11-76	EC602368	Elect./C. (Lug Type) 2200μF 63WV	24-10-93	1
11-28x	TA610031	Jack Retaining Base C (DB)	A5-5035	1	11-77	EJ254957	Lug Plate KP1L	33-3-2	1
11-29x	BA604247	Dolby P.C. Board Comp. AA-5210DB	A5-5046	1	11-78	TA605935	Trans. MT. Table	A5-5003	1
11-30x	TA610007	Spring, Meter Retainer	A5-5036	1	11-79	ZS447840	Tapping Screw #2 3x8(BR)		4
11-31x	EM604091	Meter	46-1-95	2	11-80	EZ621900	Cord Holder 4772	2-7-47	1
11-32x	TA610018	Lamp Case	A5-5037	1	11-81	MZ229138	Wire Bundle Holder N-108	2-35-1	1
11-33x	EL539684	Lamp, Fuse Type 8V 0.3A	28-2-27	1	11-82	BT602370	Power Trans. AA-5210T-1	38-4-300	1
11-34x	EJ367986	Fuse Holder 1P AC125V 5A	40-1-8	1	11-83x	BT602638	Power Trans. AA-5210T-2	38-4-299	1
11-35x	EV604080	2-axial 2-throw/Vol. V24L5DWTN 15A 250Kx2	36-3-57	2	11-84x	BT602548	Power Trans. AA-5210T-3	38-4-298	1
11-36x	TA610042	Vol. Retaining Plate	A5-5052	1	11-85x	BT604067	Power Trans. AA-5210DBT-1	38-4-303	1
		REAR PANEL BLOCK			11-86x	ZW273914	Spring Washer M4		4
11-37	SP605981	Rear Panel A	A5-5012	1	11-87	ZW273960	Nut M4		4
11-38x	SP605992	Rear Panel B (CSA)	A5-5012	1	11-88	EJ551035	4P Wrapping Terminal T-5251	32-1-36	2
11-39x	SP606003	Rear Panel C (EC)	A5-5012	1	11-89x	EJ539447	2P Earth Terminal T4460	32-1-32	1
11-40x	TA610154	Rear Panel 1 (DB)	A5-5038	1	11-90	EJ496686	Wire Clip 220-JD486010-110	2-7-16	4
11-41	EJ539763	4P Wrapping pin Jack B T5346-B	31-1-106	2	11-91x	EJ551057	Wire Clip 220-JD481010-0021(DB)	2-7-27	4
11-42	ZS570385	ISO Screw, Pan Head 3x8		4	11-92	TA605878	Lead Protector	A5-5007	1
11-43	EJ299316	Jack, 5P Din S-1 8123	31-1-24	1	11-93	BA602752	Main Amp. P.C. Board Comp. AA-5210	96-5008	1
11-44	ZS447761	Tapping Screw #2 3x6 (BR) (Black)		2	11-94	EA602763	Power Supply P.C. Board Comp. (DB)	A5-5026	1
11-45	EZ486257	Metal Terminal T-10	32-1-27	1	11-95x	BA604225	Power Supply P.C. Board Comp.	A5-5047	1
11-46x	ZW273802	Toothed Lock Washer M3		1	11-96x	EZ629820	Main Amp. Cushion	A5-5090	1
11-47x	EC551160	Cermic/C. NB821 YZ 0.01μF(Z) 1.4KWV	24-4-55	1	11-97x	EA606914	Fuse P.C. Board (EC,CSA)	A5-5062	1
11-48	EJ233370	Socket (Volt. Selector) S-18010	40-2-3	1	11-98x	EJ592503	Fuse Clip, P.C. Board H0426 (EC, CSA)	40-1-37	10
11-49	ZS421740	Screw, Pan Head 3x8		6	11-99x	EJ539662	Wrapping Post 1x17 (EC, CSA)	32-1-48	10
					11-100x	EZ605913	Fuse Angle A5 (EC,CSA)	A5-5064	2
					11-101x	EZ605902	Terminal Mt. Table (EC, CSA)	A5-5063	1
					11-102x	EZ546625	Connector Insulator Paper (EC, CSA)	ND-1081	1
					11-103x	EJ561227	Terminal No. 500/2 (EC, CSA)	52-1-19	1

When ordering parts, please describe Parts Number, Serial Number, and Model Number in detail.

FIG. 12 PHOTO OF FINAL ASSEMBLY BLOCK

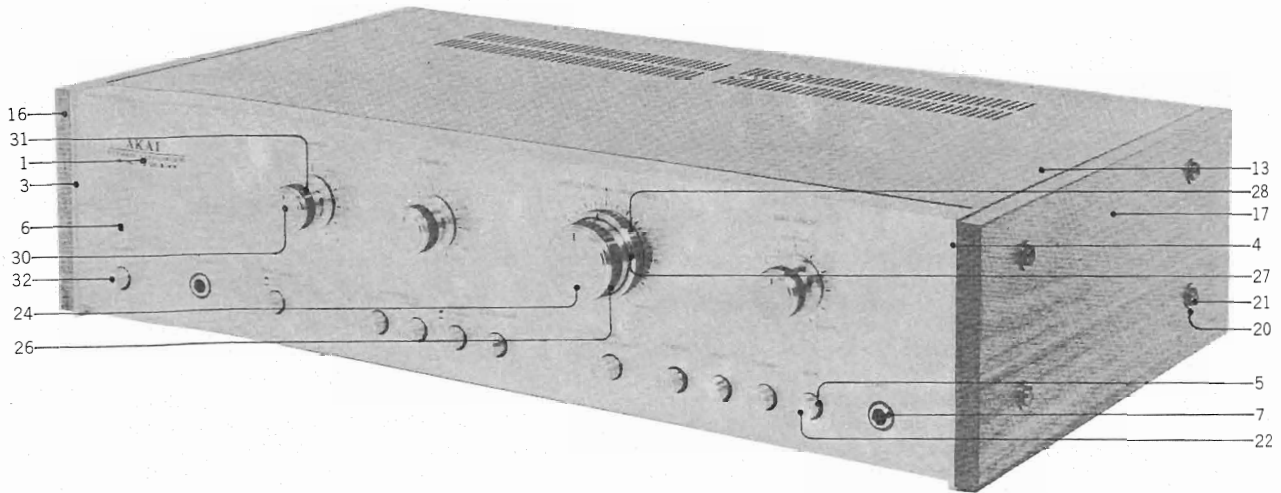

FINAL ASSEMBLY BLOCK

Ref. No.	Parts No.	Description	Schematic No.	Q'ty	Ref. No.	Parts No.	Description	Schematic No.	Q'ty
FRONT PANEL BLOCK									
12-1	SP606014	Front Panel	A5-5014	1	12-39x	TA539537	2P Fuse Holder Cover	2-34-78	1
12-2x	TA610200	Front Panel B (DB)	A5-5041	1	12-40x	EF601986	Fuse 1.5A 125V (CSA)	39-1-52	2
12-3	TA609794	Side Fitting Left	A5-5017	1	12-41x	EF623092	Fuse (SEMKO) 1.25A(EC)	39-1-54	2
12-4	TA609816	Side Fitting Right	A5-5017	1	12-42x	EF562746	Fuse 3A 125V (CSA)	39-1-47	1
12-5	TA545905	Push Button Bush	98-5061	11	12-43x	EF623103	Fuse (SEMKO T Type) 1AT (EC)	39-1-53	1
12-6	SZ457975	Lamp Lens B	55-5012	1	12-44x	EF602627	Fuse 0.3A 125V (CSA)	39-1-52	1
ASSEMBLY BLOCK									
12-7	ZW526577	Collar B, Jack	MC-5006	2	12-45x	EF623114	Fuse (SEMKO T Type) 200MAT (EC)	39-1-53	1
12-8x	SP606025	Bottom Plate	A5-5018	1	12-46x	EF588420	Fuse 1A 125V	39-1-52	1
12-9x	TA610187	Bottom Plate B (DB)	A5-5040	1	12-47x	EF623125	Fuse (SEMKO T Type) 2.5AT (EC)	39-1-53	1
12-10x	ZS447840	Tapping Screw #2 3x8(BR)		8	12-48x	EF563703	Fuse 2A 250V	39-1-50	1
12-11x	SA609952	Tran Leg D	2-6-11	4	12-49x	EJ552778	Short Pin Plug ASB-2	42-1-65	2
12-12x	ZW565942	Tapping Screw #2 4x8 Pan Head		4	12-50x	EJ550912	Speaker Plug ASP-1	42-1-64	2
12-13	SP606036	Upper Plate	A5-5019	1	12-51x	EJ602346	Speaker Plug CP045-1-1	42-1-75	2
12-14x	TA610108	Upper Plate B (DB)	A5-5043	1					
12-15x	ZS447761	Tapping Screw #2 3x6 (BR) (Black)		2					
12-16	SP605946	Side Plate A (Left)	A5-5020	1					
12-17	SP606047	Side Plate B (Right)	A5-5020	1					
12-18x	SP610143	Side Plate D (Left) (DB)	A5-5059	1					
12-19x	SP610435	Side Plate C (Right) (DB)	A5-5059	1					
12-20	ZW602381	Washer D4.2x11x1t		8					
12-21	ZW552824	ISO Screw, Binding Head 4x18		8					
12-22	SK531224	Push Button Knob	9F-5051	10					
12-23x	SB628108	Push Button F (Green) (DB)	9F-5051	1					
12-24	SK609838	Volume Knob	A5-5049	1					
12-25x	ZS444240	Set Screw, Hexagon Socket 4x8 (CUP/P.)		1					
12-26	MB609851	Knob Rubber Ring C	A5-5054	1					
12-27	SK631192	Memory Knob Ring	A5-5048	1					
12-28	MB605880	Knob Rubber Ring D	A5-5055	1					
12-29x	ZW493312	Washer D6.2x10x1t		1					
12-30	SK627535	Single Knob B-2	A5-5053	3					
12-31	MB551103	Double Knob Lower Rubber Ring	3-10-5	3					
12-32	SK627524	Push Button Knob G	9F-5051	1					
12-33x	SK628110	Double Knob 2 (DB)	A5-5087	2					
12-34x	MB610097	Knob Rubber Ring	A5-5419	2					
12-35x	SK628121	Double Knob 1	A5-5086	2					
12-36x	MB610086	Knob Rubber Ring	A5-5051	2					
12-37x	EF563681	Fuse 1A 250V	39-1-50	1					
12-38x	EF563692	Fuse 1.5A 250V	39-1-50	2					

When ordering parts, please describe Parts Number, Serial Number, and Model Number in detail.

INDEX

Parts No.	Ref. No. & Symbol No.	Parts No.	Ref. No. & Symbol No.	Parts No.	Ref. No. & Symbol No.	Parts No.	Ref. No. & Symbol No.	Parts No.	Ref. No. & Symbol No.
BA602752	1-1x	EC336104	1-C7	ED558033	6-D1to4	ET517263	2-TR1	TA545905	12-5
BA602752	11-93	EC336104	2-C12	ED560913	10-D3, 4	ET517263	2-TR3	TA604236	11-2x
BA602763	5-1x	EC336115	6-C10	ED560913	10-D6	ET517263	4-TR1	TA605878	11-92
BA602763	11-94	EC336115	10-C21	ED560913	10-D11,12	ET517263	10-TR3, 4	TA605924	11-70
BA602807	2-1x	EC336126	10-C20	ED560913	10-D14	ET517263	10-TR6	TA605935	11-78
BA602807	11-25	EC346735	2-C1	EF562746	12-42x	ET517263	10-TR9	TA605970	11-1
BA602818	3-1x	EC346735	2-C13	EF563681	12-37x	ET517263	10-TR13,14	TA606058	11-71
BA602818	11-17	EC346735	5-C4	EF563692	12-38x	ET517263	10-TR16	TA606576	11-9x
BA602820	9-1x	EC349604	5-C1	EF563703	11-66x	ET517263	10-TR19	TA609761	11-3
BA602820	11-12	EC349604	6-C5, 6	EF563703	12-48x	ET510841	10-TR1, 2	TA609761	11-4x
BA602831	7-1x	EC350616	3-C15to18	EF588420	12-46x	ET520841	10-TR7	TA609772	11-13
BA602831	11-20	EC354947	1-C1	EF601986	12-40x	ET520841	10-TR11,12	TA609783	11-22
BA604225	6-1x	EC354947	1-C5	EF602627	12-44x	ET520841	10-TR17	TA609794	12-3
BA604225	11-95x	EC357232	10-C10	EF623092	12-41x	ET520841	10-TR21,22	TA609816	12-4
BA604247	10-1x	EC357232	10-C38	EF623103	12-43x	ET537300	6-TR2	TA610007	11-30x
BA604247	11-29x	EC357827	10-C14	EF623114	12-45x	ET555952	2-TR2	TA610018	11-32x
BA604258	4-1x	EC357827	10-C42	EF623125	12-47x	ET557976	10-TR5	TA610031	11-28x
BA604258	11-18x	EC362125	10-C22	EJ233370	11-48	ET557976	10-TR10	TA610042	11-36x
BA604260	8-1x	EC362125	10-C48	EJ254957	11-77	ET557976	10-TR15	TA610108	12-14x
BA604260	11-21x	EC362158	10-C24	EJ299316	11-43	ET557976	10-TR20	TA610132	11-73x
BT602370	11-82	EC362158	10-C50	EJ367986	11-34x	ET562858	1-TR2, 3	TA610154	11-40x
BT602548	11-84x	EC372148	1-C11	EJ378944	11-52	ET562860	1-TR4	TA610187	12-9x
BT602638	11-83x	EC377212	1-C6	EJ391094	3-J1	ET602460	3-TR1to4	TA610200	12-2x
BT604067	11-85x	EC377212	1-C8	EJ391094	4-J1	ET604124	4-TR2	TA610446	11-72x
EA606914	11-97x	EC377212	1-C12	EJ391083	8-J1	EV221815	1-VR2	ZS325495	1-6
EC220127	3-C1, 2	EC379124	8-C5, 6	EJ391083	9-J1	EV383398	1-VR1	ZS325495	11-14
EC220127	4-C1	EC379157	10-C2	EJ496686	11-90	EV484863	10-VR3	ZS325495	11-74
EC220432	2-C14	EC379192	7-C3, 4	EJ539447	11-89x	EV484863	10-VR6	ZS379350	1-5
EC220432	3-C5, 6	EC379192	8-C2, 3	EJ539662	1-2	EV499364	10-VR2	ZS421740	11-49
EC220432	4-C5	EC379214	2-C7, 8	EJ539662	2-2	EV499364	10-VR5	ZS422076	11-8
EC220994	2-C10	EC379765	3-C21,22	EJ539662	3-2	EV560136	10-VR1	ZS444240	12-25x
EC220994	3-C7, 8	EC379765	4-C8	EJ539662	4-2	EV560136	10-VR4	ZS447761	11-44
EC220994	10-C3	EC379833	7-C7, 8	EJ539662	5-2	EV602414	11-26	ZS447761	12-15x
EC250716	2-C9	EC379237	7-C1, 2	EJ539662	6-2	EV602425	11-27	ZS447840	11-79
EC250716	10-C12	EC389237	8-C1	EJ539662	7-2	EV602458	2-VR1, 2	ZS447840	12-10x
EC250716	10-C40	EC389237	8-C4	EJ539662	8-2	EV604080	11-35x	ZS463353	11-56x
EC250841	4-C9	EC398957	1-C10	EJ539662	9-2	EW315448	11-63x	ZS570385	11-42
EC250841	10-C1	EC399565	1-C3	EJ539662	10-2	EW374894	11-61	ZS570385	11-51
EC251122	10-C23	EC411827	8-C7, 8	EJ539662	11-99x	EW559260	11-62x	ZW260368	11-24
EC251122	10-C49	EC423562	3-C11to14	EJ539763	11-41	EZ225180	11-23x	ZW273802	11-46x
EC251291	2-C2	EC432810	10-C16	EJ539796	11-55	EZ246936	11-65x	ZW273881	11-67x
EC251291	5-C5	EC432810	10-C44	EJ550912	12-50x	EZ382263	11-64x	ZW273914	11-69x
EC251291	10-C26	EC450055	3-C3, 4	EJ551035	11-88	EZ478675	11-19	ZW273914	11-86x
EC251291	10-C30	EC450055	4-C2	EJ551057	11-91x	EZ486257	11-45	ZW273960	11-87
EC251291	10-C32,33	EC450055	10-C13	EJ551316	11-50	EZ546625	11-102x	ZW413188	11-68x
EC251291	10-C52	EC450055	10-C41	EJ551340	11-58	EZ594325	11-75	ZW434597	11-15x
EC251291	10-C56	EC450270	1-C9	EJ552778	12-49x	EZ602403	1-4	ZW493312	12-29x
EC251291	10-C58,59	EC450527	2-C6	EJ554578	11-57	EZ605902	11-101x	ZW516993	11-54x
EC290520	1-C4	EC450527	4-C11	EJ561227	11-103x	EZ605913	11-100x	ZW526577	12-7
EC290531	2-C3	EC479621	4-C10	EJ592503	11-98x	EZ605957	1-3	ZW552824	12-21
EC290531	4-C7	EC487394	2-C4	EJ602346	12-51x	EZ621900	11-80	ZW554624	11-16
EC290531	10-C28	EC495865	10-C11	EJ602537	11-53	EZ629820	11-96x	ZW565942	12-12x
EC290531	10-C54	EC495865	10-C39	EL458864	11-10	MB551103	12-31	ZW602381	12-20
EC302253	10-C8	EC516767	4-C4	EL539684	11-33x	MB605880	12-28		
EC302321	3-C19,20	EC551160	6-C1to4	EM604091	11-31x	MB609851	12-26		
EC308711	7-C5, 6	EC551160	11-7x	EO496350	10-L1	MB610086	12-36x		
EC313108	3-C9, 10	EC551160	11-47x	EO496350	10-L3	MB610097	12-34x		
EC320040	10-C27	EC556075	4-C3	EO496361	10-L2	MZ229138	11-81		
EC320040	10-C53	EC556075	4-C6	EO496361	10-L4	SA609952	12-11x		
EC320051	10-C4, 5	EC556525	2-C11	ER364994	11-60x	SB628108	12-23x		
EC320051	10-C9	EC556525	10-C18	ER452777	11-59x	SK531224	12-22		
EC320051	10-C15	EC556525	10-C46	ER517094	8-R1, 2	SK609838	12-24		
EC320051	10-C17	EC602368	11-76	ER559034	9-R1, 2	SK627524	12-32		
EC320051	10-C19	EC603112	5-C2, 3	ER604078	6-R2	SK627535	12-30		
EC320051	10-C25	EC603112	6-C8, 9	ER622978	1-R16,17	SK628110	12-33x		
EC320051	10-C29	EC604440	10-C34	ES469541	11-5	SK628121	12-35x		
EC320051	10-C31	EC604440	10-C60	ES551171	9-SW1	SK631192	12-27		
EC320051	10-C35to37	ED219464	10-D1	ES562781	7-SW1	SP605946	12-16		
EC320051	10-C43	ED219464	10-D5	ES602594	11-6x	SP605981	11-37		
EC320051	10-C45	ED219464	10-D7,8,9	ES628560	7-SW2	SP605992	11-38x		
EC320051	10-C47	ED219464	10-D13	ES628626	3-SW1	SP606003	11-39x		
EC320051	10-C51	ED219464	10-D15,16	ES628637	10-SW1	SP606014	12-1		
EC320051	10-C55	ED224526	6-D5to8	ES628648	4-SW1	SP606025	12-8x		
EC320051	10-C57	ED485370	10-TH1	ES628650	8-SW1	SP606036	12-13		
EC320051	10-C61,62	ED490511	1-D1	ET375603	1-TR5, 6	SP606047	12-17		
EC321221	1-C2	ED491130	10-D2	ET452531	6-TR1	SP610143	12-18x		
EC321221	6-C7	ED491130	10-D10	ET491051	10-TR8	SP610435	12-19x		
EC329771	2-C5	ED511907	5-D5to8	ET491051	10-TR18	SZ457975	12-6		
EC331705	10-C7	ED511918	6-D9	ET511920	5-TR1	TA510502	11-11		
EC331828	10-C6	ED558033	5-D1to4	ET516263	1-TR1	TA539537	12-39x		

SECTION 3

SCHEMATIC DIAGRAM

1. AA-5210 SCHEMATIC DIAGRAM
2. AA-5210 DB SCHMATIC DIAGRAM
3. AA-5210 DB (DOLBY) SCHMATIC DIAGRAM

AA-5210

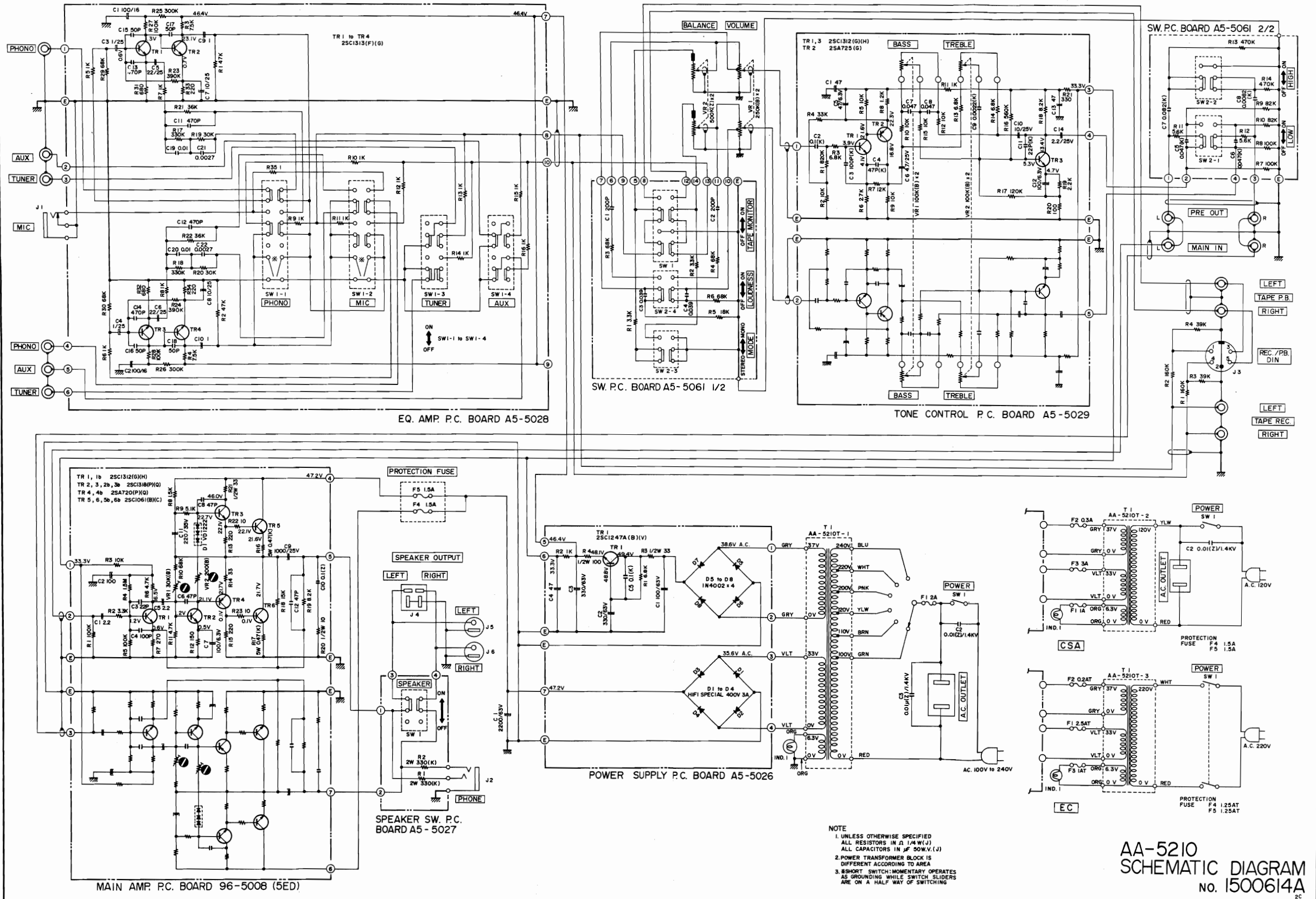

NOTE
 1. UNLESS OTHERWISE SPECIFIED
 ALL RESISTORS IN Ω, 1/4W(J)
 ALL CAPACITORS IN µF 50W.V.(J)
 2. POWER TRANSFORMER BLOCK IS
 DIFFERENT ACCORDING TO AREA
 3. SHORT SWITCH: MOMENTARY OPERATES
 AS GROUNDING WHILE SWITCH SLIDERS
 ARE ON A HALF WAY OF SWITCHING

AA-5210
 SCHEMATIC DIAGRAM
 No. 1500614A

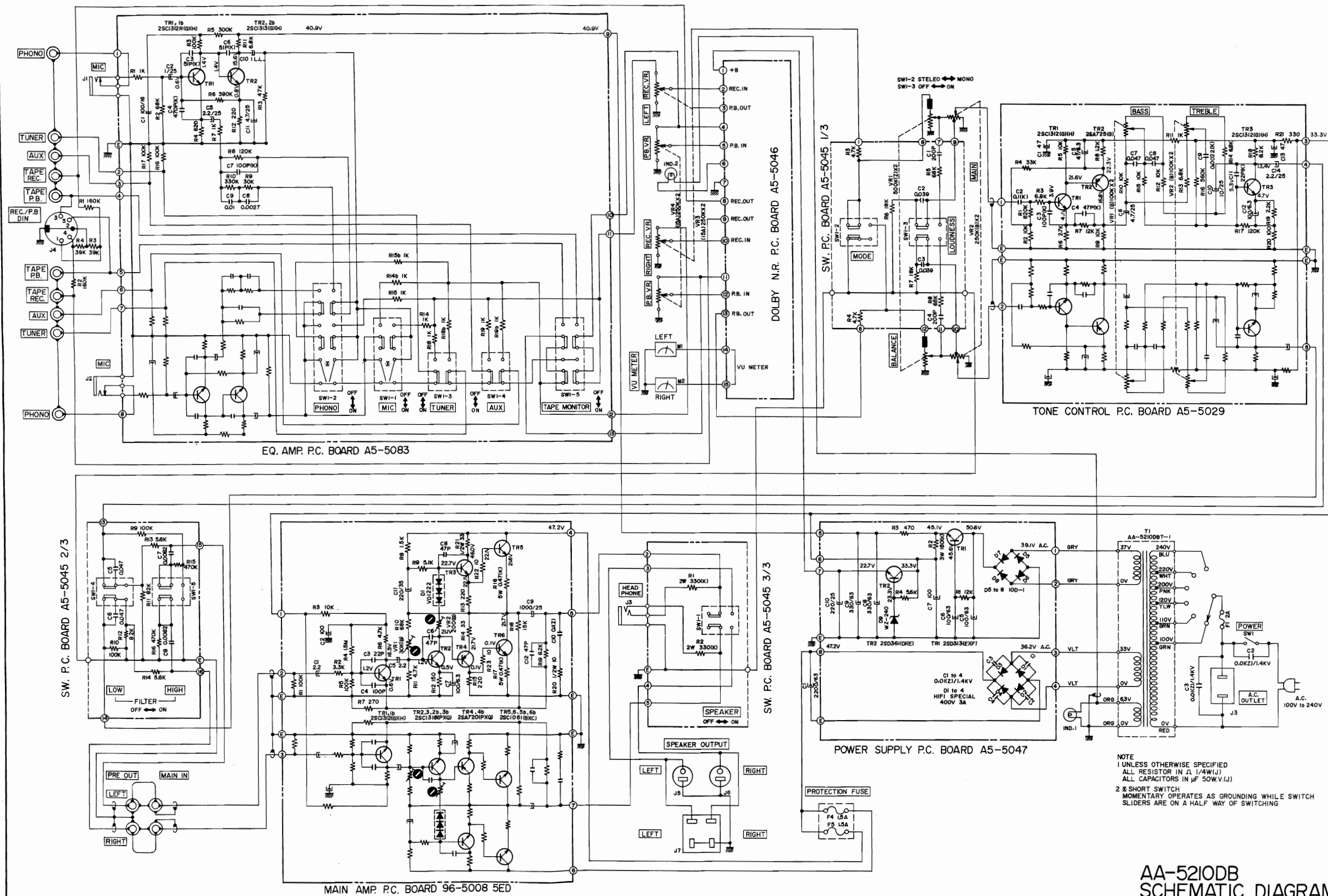

NOTE
 1 UNLESS OTHERWISE SPECIFIED
 ALL RESISTOR IN Ω, 1/4W (1)
 ALL CAPACITOR IN µF 50W.V.(1)
 2 X SHORT SWITCH
 MOMENTARY OPERATES AS GROUNDING WHILE SWITCH
 SLIDERS ARE ON A HALF WAY OF SWITCHING

AA-5210DB

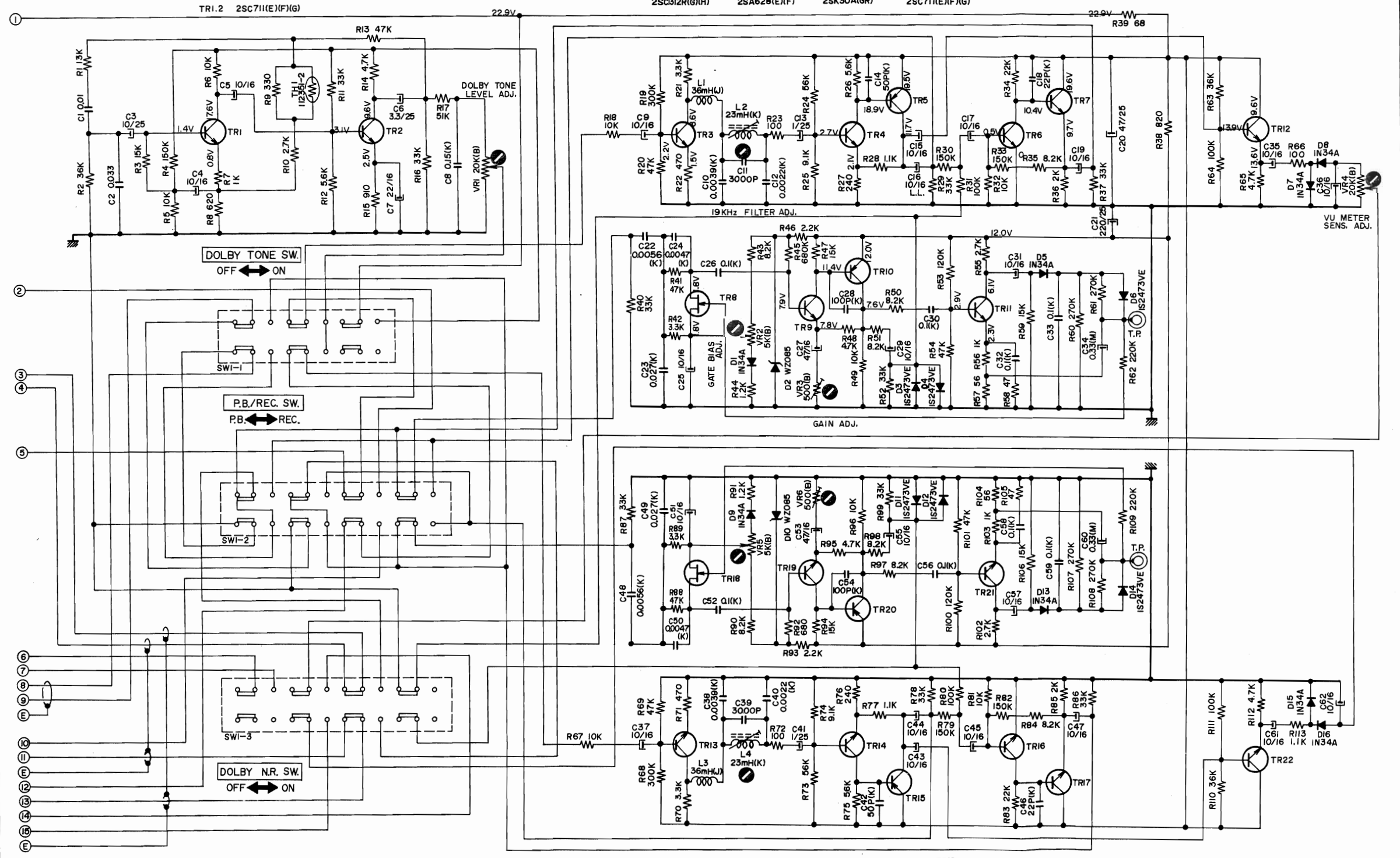

DOLBY N.R. P.C. BOARD A5-5046

AA-5210DB (DOLBY)
 SCHEMATIC DIAGRAM
 NO.2-2 1500617A
 2C