

# SERVICE MANUAL

**AKAI AMPLIFIER**

**MODEL AA-8500**



**TABLE OF CONTENTS**

I.	SPECIFICATIONS .....	3
II.	CONTROLS AND CONNECTIONS .....	4
III.	TUNER AND AMPLIFIER ADJUSTMENT .....	6
	1. POWER AMPLIFIER CIRCUIT ADJUSTMENTS	
	2. ADJUSTMENT OF PROTECTIVE CIRCUIT FOR POWER TRANSISTORS	
	3. TUNER SECTION ADJUSTMENTS	
	4. SEPARATION ADJUSTMENT	
	5. AM-IF CIRCUIT ADJUSTMENT	
	6. DIAL MECHANISM ADJUSTMENT	
IV.	TROUBLE SHOOTING CHART .....	12
V.	DIAL STRINGS DISASSEMBLY .....	14
VI.	COMPOSITE VIEW OF COMPONENTS .....	16
VII.	SCHEMATIC DIAGRAM	

# I. SPECIFICATIONS

---

## FM TUNER SECTION

RECEIVING FREQUENCY RANGE	:	87.5 to 108.5 MHz (U.S. Ch.)
	:	75.5 to 90.5 MHz (JAPAN Ch.)
IF FREQUENCY	:	10.7 MHz
SENSITIVITY	:	2 $\mu$ V (IHF) at 98 MHz
SELECTIVITY	:	Better than 60 dB ( $\pm$ 400 kHz)
HARMONIC DISTORTION	:	
	: MONO	: Less than 0.3% (400 Hz, 100% Mod.)
	: STEREO	: Less than 1.0% (400 Hz, 100% Mod.)
IMAGE FREQUENCY RATIO	:	Better than 90 dB at 98 MHz
IF REJECTION RATIO	:	Better than 90 dB at 98 MHz
CAPTURE RATIO	:	Less than 2 dB (IHF)
SPURIOUS RADIATION	:	Less than 34 dB
MUTING SENSITIVITY	:	20 dB $\pm$ 2 dB
SIGNAL TO NOISE RATIO	:	Better than 60 dB
FM STEREO SEPARATION	:	Better than 35 dB

## AM TUNER SECTION

RECEIVING FREQUENCY RANGE	:	520 – 1650 kHz
IF FREQUENCY	:	455 kHz
SENSITIVITY	: DIRECT	: 10 $\mu$ V (IHF)
	: LOOP	: 200 $\mu$ V (IHF)
SELECTIVITY	:	Better than 30 dB ( $\pm$ 20 kHz)
IMAGE FREQUENCY RATIO	:	Better than 70 dB
IF REJECTION RATIO	:	Better than 70 dB
HARMONIC DISTORTION	:	Less than 1.0% (400 Hz, 30% Mod.)
SIGNAL TO NOISE RATIO	:	Better than 50 dB

## AUDIO SECTION

POWER OUTPUT	:	
	: (MUSIC POWER)	: 240 W (120 W/120 W) at 4 $\Omega$
		: 170 W (85 W/85 W) at 8 $\Omega$
	: (RATED POWER)	: 180 W (90 W/90 W) at 4 $\Omega$
		: 130 W (65 W/65 W) at 8 $\Omega$
POWER BAND WIDTH	:	20 Hz – 30 kHz (at 8 $\Omega$ )
FREQUENCY RESPONSE	:	
	: (AUX)	: 20 Hz – 50 kHz ( $-3$ dB)
	: (PHONO)	: RIAA $\pm$ 1 dB
HARMONIC DISTORTION	:	Less than 0.05%, at 8 $\Omega$ , 30 W
INPUT SENSITIVITY	:	
	: PHONO	: 3 mV (Impedance 50 k $\Omega$ )
	: AUX.	: 150 mV (Impedance 50 k $\Omega$ )
	: TAPE MONITOR (PIN)	: 200 mV (Impedance 50 k $\Omega$ )
	: TAPE MONITOR (DIN)	: 200 mV (Impedance 50 k $\Omega$ )
	: MAIN	: 0.77 mV (Impedance 100 k $\Omega$ )

## TAPE REC. OUTPUT

	:	(PIN)	:	150 mV
	:	(DIN)	:	25 mV
HUM AND NOISE (BELOW RATED OUTPUT)	:	PHONO	:	Better than 70 dB
	:	AUX.	:	Better than 80 dB
	:	VOLUME MINIMUM	:	Less than 2 mV
CHANNEL SEPARATION (AT RATED OUTPUT)	:	PHONO	:	Better than 60 dB (at 1 kHz)
	:	AUX.	:	Better than 60 dB (at 1 kHz)
TONE CONTROL	:	BASS	:	100 Hz $\pm$ 10 dB ( $\pm$ 1 dB)
	:	TREBLE	:	10 kHz $\pm$ 10 dB ( $\pm$ 1 dB)
LOUDNESS CONTROL	:		:	100 Hz 8 dB $\pm$ 2 dB
( $-30$ dB FROM VOLUME MAXIMUM)	:		:	10 kHz 4 dB $\pm$ 1 dB
FILTER	:	HIGH	:	10 kHz $-5$ dB $\pm$ 1 dB
	:	LOW	:	50 Hz $-9$ dB $\pm$ 1 dB
SEMI-CONDUCTORS	:		:	65 Silicon Transistors
			:	1 FET
			:	2 IC
			:	29 Diodes
			:	1 VC Diode
			:	1 Tuner Diode
			:	4 Thermistors
POWER CONSUMPTION	:		:	350 W
POWER SOURCE	:		:	AC 100 to 240 V AC; 50/60 Hz
DIMENSIONS	:		:	165(H) $\times$ 487(W) $\times$ 346(D) mm
			:	(6.6 $\times$ 19.5 $\times$ 13.8")
WEIGHT	:		:	16 kg (35.2 lbs.)

## II. CONTROLS & CONNECTION

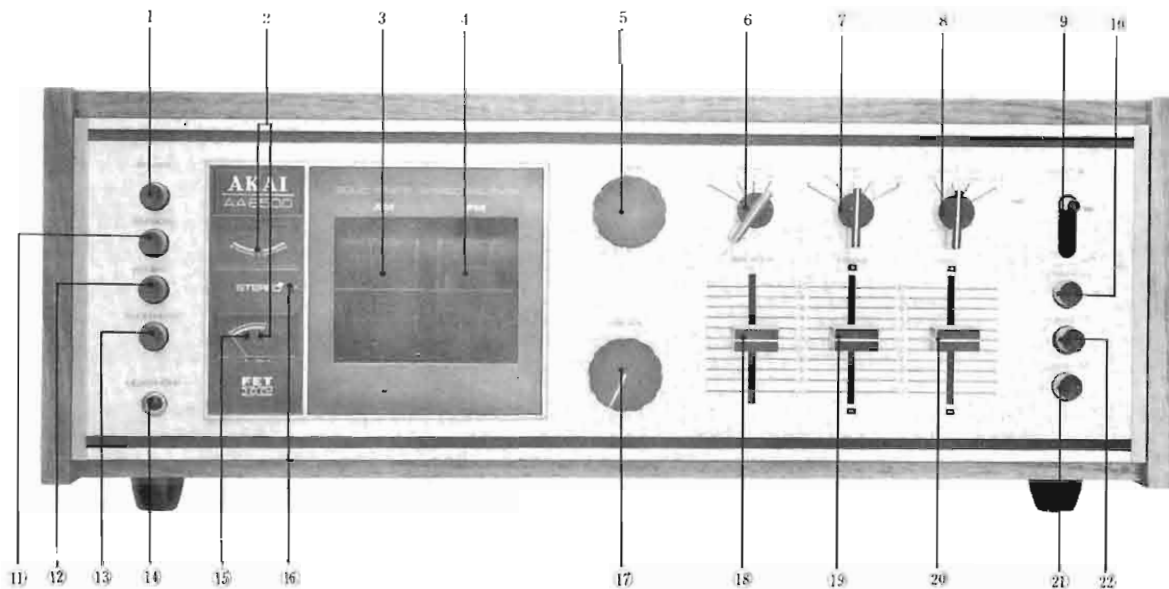

- ① POWER SWITCH: Depress to turn "ON"
- ② FM AND FM/AM SIGNAL STRENGTH METERS (for FM tuning): While observing both meters, rotate TUNING KNOB to tune in broadcasted signals. When signal is strong, the indicator needle of the FM/AM Meter (lower meter) will swing to the right. For good tuning, the needle must be within the green mark at extreme right.  
Movement of the FM Meter (upper meter) needle to the left and right (indicates the strength of the broadcasted signals. Mid-scale indicates perfect tuning. Turn TUNING KNOB until perfect tuning is attained. The Dial Scales are much easier to see. The AM DIAL SCALE will light up when the SELECTOR SWITCH is set to "AM" position.
- ③ AM DIAL SCALE: With this new type dial mechanism, the Dial Scales are much easier to see. The AM DIAL SCALE will light up when the SELECTOR SWITCH is set to "AM" position.
- ④ FM DIAL SCALE: The FM DIAL SCALE will light up when the SELECTOR SWITCH is set to "FM" position.
- ⑤ TUNING KNOB: For selection of AM or FM stations. Rotate Knob for receiving desired broadcasted signals.
- ⑥ SPEAKER SYSTEM SWITCH: For selection of "A + B", "A", or "B" speaker systems. When at "Off" position, the sound is cut off from all speaker systems. (Use this setting for private headphone listening.)
- ⑦ MODE SWITCH: For automatic selection of speaker systems.  
Left: Left speaker(s) only  
Right: Right speaker(s) only  
Stereo: Left and Right (Stereo tracks)  
L & R: Left and Right (monaural track through both speakers)  
Rev: Reverse left and right speaker sound (can be used to check balance of sound).
- ⑧ SELECTOR SWITCH: Set TAPE MONITOR SWITCH to "SOURCE" and select program source.  
AM: For AM Radio Reception  
FM: For FM Radio Reception  
PHONO: For Record player  
AUX: For Tape Recorders and external tuners or other sources connected to AUX terminals at rear of amplifier (high output players, ceramic or crystal pick-up, etc).
- ⑨ TAPE MONITOR SWITCH: For sound during recording or playback with a 3-head tape recorder, depress to "Tape Play" position. For sound from other sources (Record Player, FM, AM, etc.), set to "Source" position.
- ⑩ LOUDNESS SWITCH: Boosts bass and treble response at low volume level.
- ⑪ FM MUTE SWITCH: For use when receiving FM signals. When this switch is depressed and no signals are being received, interference is muted. When signals are being received, interstation tuning noise is automatically eliminated. (Do not use when tuning in weak stations).
- ⑫ FM AFC (Automatic Frequency Control) SWITCH: After the FM station has been tuned in and the signal strength meters indicate perfect tuning, depress this switch for finer tuning-perfection (perfects signal frequency even to point beyond capacity of the human ear).
- ⑬ AUDIO MUTE SWITCH: Reduces audio level to soft audibility. When switch is released audio level will be restored to former setting.
- ⑭ STEREO HEADPHONE JACK: Accommodates Stereo Headphones for monitoring or private listening. (Turn Speaker Switch to "Off" position for private listening). Dynamic Stereo type headphones should be used. AKAI Model No. ASE-20 is highly recommended.
- ⑮ FM/AM SIGNAL STRENGTH METER (for AM tuning): When receiving AM Signal broadcasts, the needle at the right scale indicates perfect tuning. When the broadcasted signals are very strong, the needle will point to the extreme right.
- ⑯ FM STEREO TUNING INDICATOR LAMP: When FM Stereo signals are being received, this lamp will automatically light.
- ⑰ VOLUME CONTROL KNOB: For overall adjustment of sound level (both channels). Turning Knob clockwise increases the volume.  
Caution:  
Before changing input or connections, etc., make sure that the Volume Control Knob is turned to minimum position.
- ⑱ BALANCE CONTROL KNOB: For balancing volume of left and right speakers. Sliding Knob upward will increase the volume of the left channel by reducing the output of the right channel and vice-versa.
- ⑲ TREBLE CONTROL KNOB: Use to control high range frequency response. Slide Knob upward to increase treble sound and downward to decrease treble sound.
- ⑳ BASS CONTROL KNOB: Use to control low range frequency response. Slide Knob upward to increase base sound and downward to decrease bass sound.
- ㉑ LOW FILTER SWITCH: An aid in the elimination of low frequency disturbances such as turntable rumble, etc. Use only when necessary.
- ㉒ HIGH FILTER SWITCH: An aid in the elimination of high frequency surface noise such as noise caused by nearby electrical appliances, noise from old or worn tapes, or phonograph record scratch, etc. Use only when such noise exists.

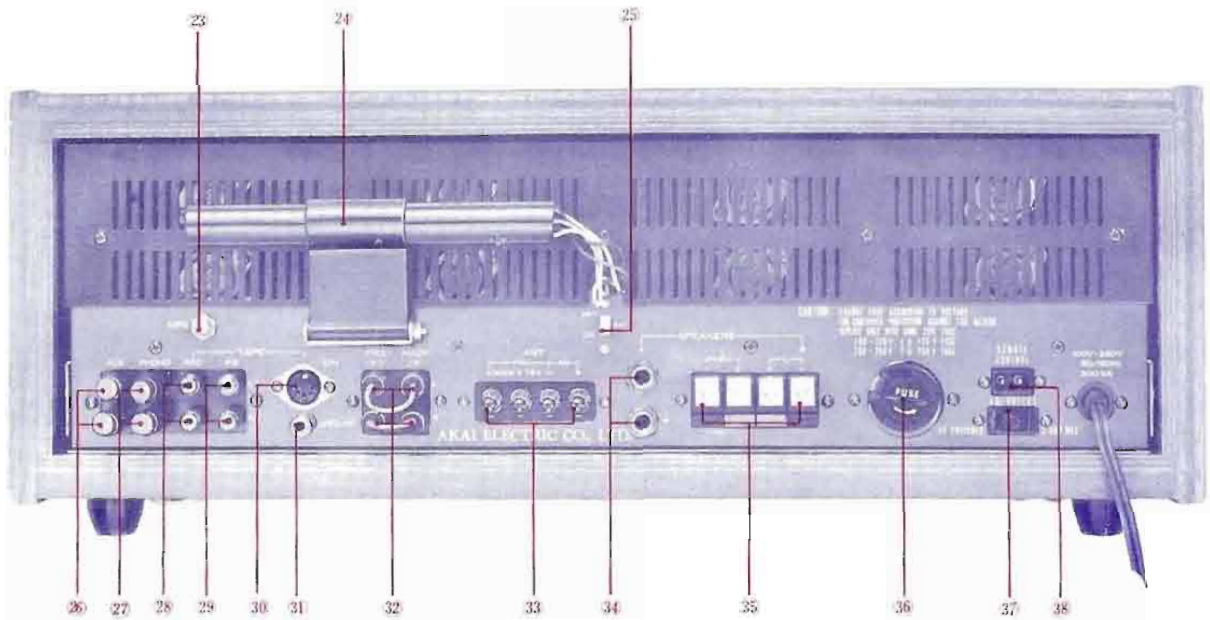

- 23 MPX (Multiplex Channel Separation Adjuster): For adjusting channel separation. Please do not touch or re-position (requires precise adjustment by qualified service engineer).
- 24 AM BAR ANTENNA: For AM broadcast reception, pull AM Bar Antenna away from back of amplifier and properly position for good reception. If broadcasted signals cannot be heard clearly, use AM antenna terminals.
- 25 AM HI-FI/DISTANCE SWITCH: Set according to strength of signals. If AM wave signals are strong, set to "HI-FI" position. If signals are weak, set to "DX" position.
- 26 AUX JACK: Use for relatively high voltage input such as radio tuner, output from the amplifier of a tape recorder or a recorder with a ceramic or crystal cartridge.
- 27 PHONO JACK: Can be used with magnetic cartridge (MM, MC, or IM). To avoid hum, these jacks must be shorted (shorting plugs provided) when not in use.
- 28 TAPE REC. JACK: Connects to line input (phono/radio) of a tape deck for recording of radio or phono programs. Recording source is selected by operating the SELECTOR SWITCH.
- 29 P.B. JACK: Connects to the line or pre-amp output of a tape deck and permits monitoring of the tape playback through use of the TAPE MONITOR SWITCH.
- 30 DIN JACK: This one-connection system can be used instead of Tape Rec. Jack and Tape P.B. Jack if the tape recorder has a corresponding connection. If your tape recorder is not equipped with a DIN Jack, AKAI Connection Cord DR-110 can be used.
- 31 GROUND TERMINAL: This terminal is for use in grounding the amp with a tape recorder, or with a record player. If this connection causes excessive noise, connect a thick cable from these terminals to a buried underground metal bar. Also when using an outside antenna, these terminals should be grounded to an underground metal bar as described above.

**Caution:**

Do not connect to a gas pipe or gas line, etc.

- 32 PRE-AMP OUTPUT JACK & MAIN AMP INPUT JACK:

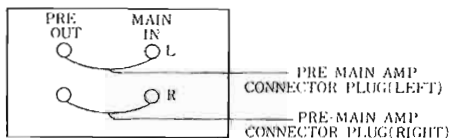

With the pre-main amp connector plugs connected as shown in the above figure, the pre-main amplifiers function normally. Removing these plugs separates the main amp from the pre-amp and only the main amp functions. This separation permits multiple amplifier operation through the main amplifier only.

**Caution:**

Be sure that the connection plugs are connected during normal operation.

- 33 ANTENNA TERMINALS

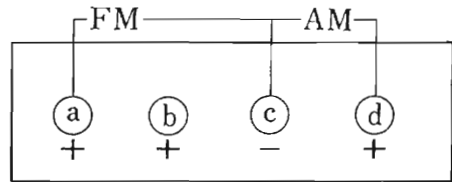

AM: (c + d) can be used if the signal is not strong enough to be picked up by the Bar Antenna.  
 FM: (a + b) For connection of 300Ω antenna feeder.  
 (a + c) Use when connecting a 75Ω coaxial cable with antenna.

- 34 SPEAKER JACKS: For connection of a single + - Plug for "A" Speaker System operation. AKAI Speaker Cord AS-170 (optional accessory) is recommended.
- 35 SPEAKER TERMINALS: Supplies output to Speaker System "B" Connect plus and minus terminals to correspond with polarity of speakers.
- 36 UNIVERSAL VOLTAGE SELECTOR & FUSE: Permits selection of voltage from 100 to 240V. Fuse must be changed to correspond with voltage.
 

100-120V .....	3A
200-240V .....	1.5A
- 37 AC OUTLET: Extra power supply for record player or tape recorder. This 300W unswitched outlet is not interlocked with the front panel power switch (power is applied even with the unit turned off).
- 38 REMOTE CONTROL SOCKET (for Audio Mute): With AKAI's remote control unit (optional accessory), the audio mute function can be remote controlled. Plug remote control cable into this socket.

### III. TUNER & AMPLIFIER ADJUSTMENT

#### 1. POWER AMPLIFIER CIRCUIT ADJUSTMENTS

In case power amplifier circuit has been repaired or power transistors have been replaced, the following adjustments are necessary for each channel:

##### 1-1 No-signal Current Adjustment of Power Amplifier

- Connect a 1.5 A full scale DC Ammeter in place of the protector fuse in the left channel amplifier. An Ammeter with range selector covering 1.5 – 0.1 A is recommended.
- Set VOLUME Knob (VR-403) on the front panel to the full counterclockwise (minimum) position.
- Turn Potentiometer VR-202 (1 KΩB, L. CH.) of the power amplifier printed board full counterclockwise, and VR-201 (100 KΩB, L. CH.) to the half way position of its movable range.
- Depress the power switch to "ON" position, and adjust VR-202 so that the Ammeter indicates 80 mA (0.08 A).
- Adjust VR-202 of the right channel amplifier in the same way.

##### 1-2 DC Balance Adjustments

Adjust the DC Balance after completing current adjustment of the power amplifier.

- Connect the audio oscillator to the AUX. input terminals of both the left and right channel amplifiers, and supply a 1,000 Hz sine wave, setting the oscillator output to zero.
- Connect an 8Ω 120 W resistor to the left and right channel speaker terminals, and connect the oscilloscope across this resistor (see Fig. 1).
- Set VOLUME Knob on the front panel to the full clockwise (maximum position).
- Gradually increase the output of the audio oscillator until the wave form on the oscilloscope (see Fig. 2) begins to be clipped. Adjust the left channel potentiometer VR-201 (100 KΩ) and the right channel VR-201 (100 KΩ) so that both upper and lower peaks of the wave forms begin to be clipped simultaneously at the same point of the curve.
- In case an audio oscillator or an oscilloscope is not available, adjust Potentiometer VR-201 (L. CH.) and VR-201 (R. CH.) so that the voltage between the plus side of the large capacity condenser which is connected to the speaker and ground is half of the supply voltage (80 V). At this time, the VOLUME knob on the front panel should be kept at minimum position.

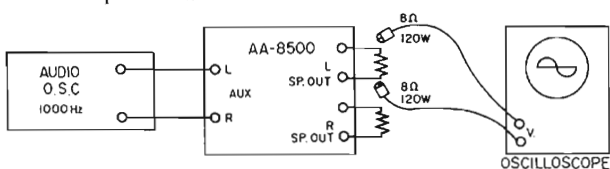

Fig. 1

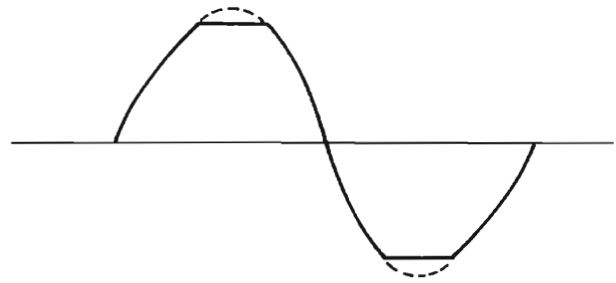

Fig. 2

#### 2. ADJUSTMENT OF PROTECTIVE CIRCUIT FOR POWER TRANSISTORS

Power transistors will be destroyed by an over-current when the output terminals of the speaker are shorted. To protect them, a protective circuit automatically operates to cut off the supply voltage in the driver stage and control the current to the power transistors.

- Connect instruments as shown in Fig. 1 and use a VTVM in place of the oscilloscope.
- Turn VOLUME knob on the front panel to the fully wound clockwise (maximum position).
- Connect a 8Ω 120 W resistor to the speaker output terminals as a load, and an Oscilloscope across the resistor.
- Set Potentiometer VR-101 (100 KΩB), the adjusting operation point of the protective circuit, to the fully wound counterclockwise position.
- Gradually increase the output of audio oscillator, which is connected to AUX terminals, until the wave form on the Oscilloscope (see Fig. 2) begins to be clipped.
- Then, exchange the load resistor at the speaker output terminals with a 4Ω 20 W resistor. At this position, adjust Potentiometer VR-101 to obtain a speaker output nearing the critical point of zero.
- Exchange the load resistor at the speaker output terminals with an 8 ohm 120 W resistor. Adjust the Oscillator output so that the wave-form on the oscilloscope is about 1/3 that of procedure 2. c). At this condition, check to see whether the protective circuits operates properly while shorting speaker terminals.

#### 3. TUNER SECTION ADJUSTMENTS

3-1 FM IF Circuit (AA-858 printed board) Adjustment  
FM-IF circuit adjustment should be made with calibrated instruments because this adjustment has a great influence on tone quality, separation, S/N, etc. in Stereo FM reception.

##### (1) Instrument Connection

- Connect the output lead of the Sweep Generator to test points (1) and (2) on the IF Printed Board (AA-858).

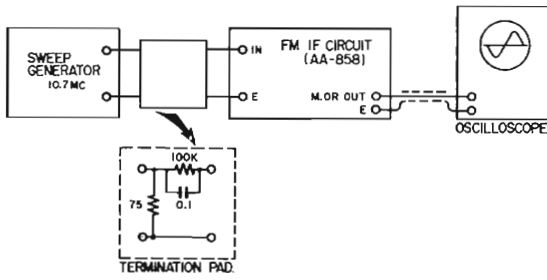

Fig. 3

- b) Connect the input lead of the Oscilloscope to test points (11) and (12).
- c) Set FREQUENCY BAND of the Sweep Generator to 10.7 MHz.
- d) Adjust V-POSITION, SWEEP-WIDTH and CENTER-FREQUENCY respectively so that the wave forms are in the center of the oscilloscope.
- e) Set STEREO MODE SWITCH on the front panel of AA-8500 to "MONO" position SELECTOR SWITCH to "FM" position and MUTE SWITCH to "Off" position.
- f) TUNING DIAL should be set to a non-receiving point on the dial.

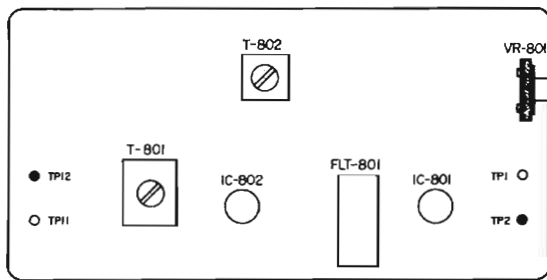

Fig. 4

(2) Adjustments

- a) For adjustment of cores of FM-IF transformers, adjust with 70 dB output level of the Sweep Generator.
- b) Adjust the upper and lower cores of T-801 to obtain the waveform shown in Fig. 5. Adjust to maximum amplitude and proper linearity between  $\pm 150$  kHz markers.
- c) Amplitude can be adjusted at the upper core of T-801 (left and right symmetry), and linearity can be adjusted at the lower core.
- d) There are 2 adjustment points for T-801. Adjust lower part at bottom position and upper part at top position (the upper part will protrude from one end of the coil and the lower part from the other end). This particular adjustment is made at the upper position.
- e) Because FLT-801 is a ceramic filter, the respective frequency responses cause the center frequency of 10.7 mHz to slightly fluctuate.

Ceramic Filter Center Frequency

Mark	Center Frequency	Tolerance
Green	10.62 MHz	$\pm 30$ kHz
Blue	10.66 MHz	"
Red	10.70 MHz	"
White	10.74 MHz	"
Yellow	10.78 MHz	"

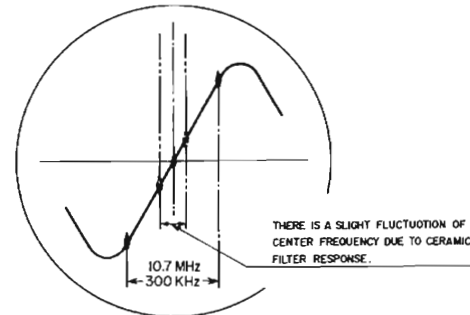
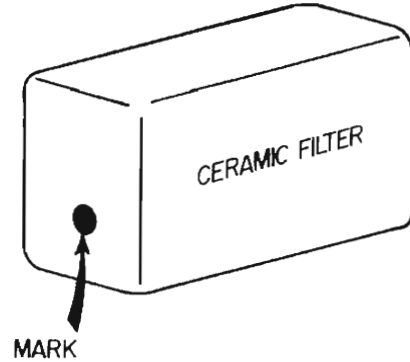

Fig. 5

3-2 Connection with Front End

(1) Instrument Connections

Use the same instruments as used in item 1), and connect the Sweep Generator output lead to FM antenna terminal and the input lead of the Oscilloscope to test point (11) and (12).

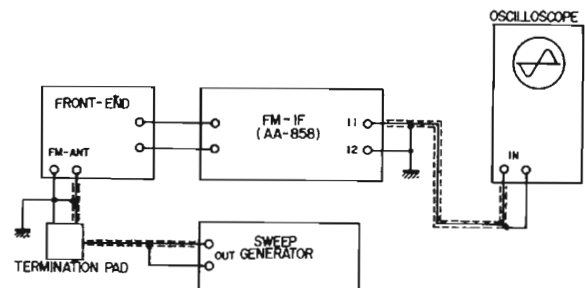

Fig. 6

- (2) Turn the core of the output transformer  $T_2$  on the front end so that the horizontal stripes visible in the center of the waveform in Fig. 8 and maximum amplitude is located in the center of the S-shaped curve. At this time, the horizontal stripe should be symmetrical at about the center line.



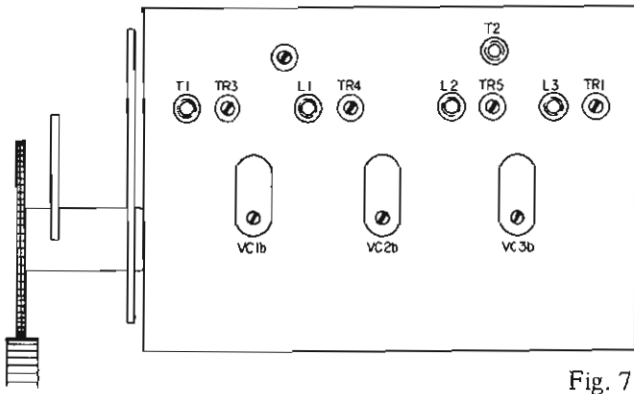

Fig. 7

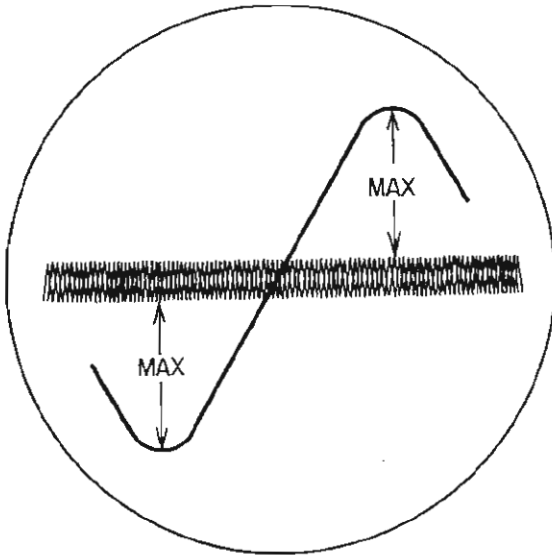

Fig. 8

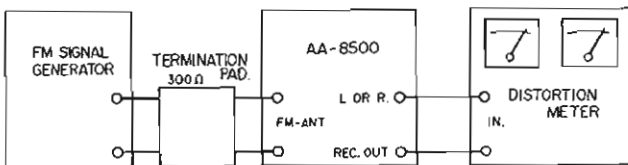

Fig. 9

### 3-3 Adjustment of FM Reception Frequency Range

#### (1) Instrument Connections

- Connect the Signal Generator (MSG-276A) output lead to the FM antenna terminals of AA-8500 through the 300 Ω terminal pad.
- Set SELECTOR switch of AA-8500 to the FM position, STEREO MODE switch to IN and AFC to OUT.
- Connect the Distortion Meter to "TAPE-REC" terminal on rear panel (See Fig. 9).

#### (2) Adjustments

- Set the Signal Generator frequency to 87.5 MHz (internal modulation 400 Hz, 75%), and the output to 60 dB (1 mV).
- Set the tuning dial of AA-8500 to the left end, and adjust  $L_2$  of the front end (see

Fig. 7) so that the Distortion meter level indicates maximum.

- Set the Signal Generator frequency to 108.5 MHz. Set the tuning dial of AA-8500 to the right end. Adjust  $C_0$  (see Fig. 7) on the front end so that the Distortion meter level indicates maximum.

- Repeat procedures b) and c) two or three times.

### 3-4 FM Tuner Tracking Adjustment

#### (1) Instrument Connections

Use the same instruments as used in item 3-3 (Fig. 9), and connect them in the same way.

#### (2) Adjustments

- Set the signal generator frequency to 90.0 MHz (internal modulation 400 Hz, 75%), and the output to 15 dB.
- Turn the tuning dial of AA-8500 to receive the 90.0 MHz signal. (Set SIGNAL GENERATOR to the position where the distortion factor on the meter is approximately 3%).
- Adjust the cores of  $L_1$  and  $T_1$  (see Fig. 7) on front end of AA-8500 so that the Distortion meter level indicates maximum and the distortion factor is minimum.
- Set the Signal Generator frequency to 106 MHz, then turn the tuning dial of AA-8500 to receive this signal. Adjust the trimmer condensers VC1a and VC2a of the tuning variable condenser in the front end so that the Distortion meter level indicates maximum and minimum distortion factors.
- Repeat procedures c) and d) two or three times.

### 3-5 Tuning Indicator Check and Muting Adjustment

- Use the same instruments as used in item 3-3 and connect them in the same way. (Fig. 9) Set the signal generator frequency to 98 MHz, and the output to 60 dB (1 mV). Turn the tuning dial of AA-8500 to receive this signal.
- Then decrease the attenuator of the Signal Generator to 20 dB and change the FM-MUTE SWITCH to "IN" position. Adjust VR-201 (50 KΩ -VR) of the FM IF BOARD (2007) until the distortion meter level indicates the critical point of "Zero".
- Next, set the signal generator output to 60 dB (1 mV) and make sure that the upper tuning indicator deflects more than 7 mm to both sides from beginning to end of signal reception. (If it is unbalanced, adjust the upper core of T-801). At this time, the distortion factor should be within 0.5% (If it is more than 0.5%, adjust the lower core of T-801).
- At this time, check to see that the lower tuning indicator is within the green area. If it is not within the green area, the core of T-802 must be adjusted until the needle indication is correct.

- e) If the upper tuner indication is “off-center” (about 7 mm to left or right), set AFC Switch to IN position and confirm that the needle returns toward center position.

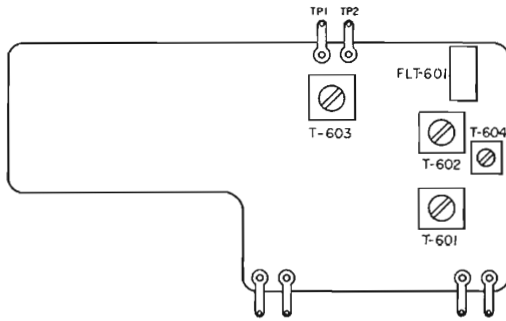

Fig. 10

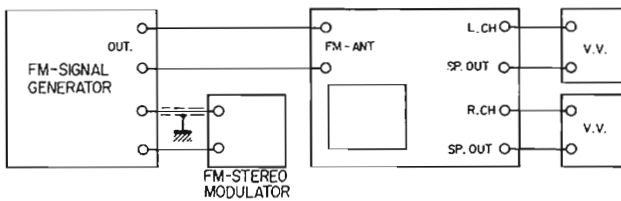

Fig. 11

- h) Set the FM stereo modulator signal to “L” and adjust T-601, T-602 and T-603 so that the millivoltmeter connected to R CH. indicates minimum. Then adjust VR-501 so that R CH. output becomes minimum.
- i) Set the FM stereo modulator signal to R CH. and note the indication of the millivoltmeter connected to L CH. Then re-adjust T-502 and VR-501 so that the leakages of R CH. and L CH. are as closely balanced as possible.
- 4-3 For adjustment of 19 kHz Filter (T-604), follow the same procedure outlined in item 4-2 (a) (b) (c) and (d) Connect a milli-voltmeter to TP-2 and connect TP-1 to ground.
- (e) Adjust core of T-604 so that the milli-voltmeter indicates minimum.

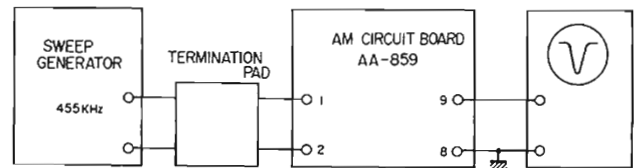

Fig. 12

#### 4. SEPARATION ADJUSTMENT

##### 4-1 Instruments Required:

- FM Signal Generator
- Stereo Modulator
- AC Voltmeter (VTVM)

##### 4-2 Instrument Connections:

- a) Adjust PILOT SIGNAL 19 kHz of the FM stereo modulator to 10% modulation and adjust MAIN SIGNAL (L + R) of the FM stereo modulator to 400 Hz, 90%. Then connect output to EXT. MOD terminals of the FM Signal Generator.
- b) Set the FM Signal Generator to EXT. MOD and its modulation to 100%.
- c) Set the FM Signal Generator frequency to 98 MHz and the output voltage to 60 dB (1 mV). Connect output to the FM-ANT terminals of Model AA-8500.
- d) Connect an 8 Ω 120 W dummy load resistor to the speaker terminal of AA-8500 and a milli-voltmeter (VTVM) to both terminal ends.
- e) Receive signal from the FM Generator by tuning the AA-8500. Adjust VOLUME on the front panel so that the milli-voltmeter indicates +10 dBm. (Stereo Mode)
- f) Turn MPX-SEPARATION variable resistor VR-501 located at the left end of the rear panel of AA-8500 fully clockwise.
- g) Set the FM stereo modulator signal to “MAIN” (L + R), and check whether the outputs of both channels are balanced. If they are out of balance, adjust by turning BALANCE knob on the front panel.

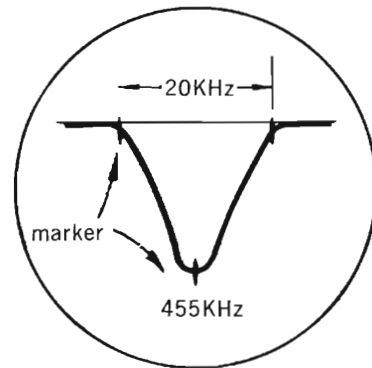

Fig. 13

#### 5. AM-IF CIRCUIT ADJUSTMENT

##### 5-1 Instrument Connections

##### 5-2 Adjustments

- a) Connect the Sweep Generator output lead to test point (1) and (2) of the AM-IF circuit board (AA-859). Connect the oscilloscope input lead to test point (9) and (8). (Fig. 12).
- b) Set the Sweep Generator FREQUENCY BAND to 455 kHz. Adjust V-POSITION, SWEEP-WIDTH, and CENTER FREQUENCY respectively so that the waveform is at the center of the Oscilloscope.
- c) Turn SELECTOR Switch on the front panel of AA-8500 to AM position, VOLUME to minimum position, and set AM Sensitivity SELECTOR Switch (rear panel) to DX position. Then adjust the cores of T-903 (yellow), T-904 (white), and T-905 (black) to obtain the waveform as shown in Fig. 13.

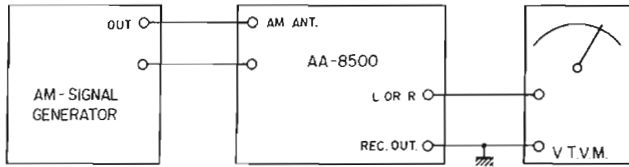

Fig. 14

### 5-3 AM Receiving Frequency Range Adjustment

#### (1) Instrument Connections

- a) Connect the AM signal generator to the AA-8500 AM antenna terminals. Connect the VTVM to Left or Right channel (TAPE REC Terminal on rear panel).
- b) After setting AA-8500 to AM, set the dial to the left end. Set the AM signal generator to 400 Hz, 30% internal modulation, frequency to 520 kHz, and output to 40 dB (100  $\mu$ V).
- c) Adjust the core of AM local oscillator transformer T-902 on AM-IF printed board (AA-859) so that the milli-voltmeter indicates maximum.
- d) Then, turn the tuning dial of the AA-8500 to the right end. Set the AM signal generator frequency to 1,650 kHz and adjust trimmer variable condenser VC3b of the AM local oscillator variable condenser of the front end so that the milli-voltmeter indicates maximum.
- e) Repeat procedures c) and d) two or three times.

### 5-4 AM Tuner Tracking Adjustment

#### (1) Instrument Connections

Use the same instruments and connections as shown in (Fig. 14).

#### (2) Adjustment

- a) Set the AM signal generator frequency to 600 kHz (internal modulation 400 Hz, 30%) and the output to 50 dB (310  $\mu$ V).
- b) Turn the dial of AA-8500 to receive the 600 kHz signal.
- c) Adjust the RF transformer to T-901 on the AM-IF printed board (AA-859) and core of the Ferrite Bar Antenna so that the milli-voltmeter which is connected to the speaker terminals indicates maximum.
- d) Next, set the AM signal generator frequency to 1,400 kHz, and turn the tuning dial of AA-8500 to receive the 1,400 kHz signal. Adjust trimmer condensers VC1b and VC2b which are variable condensers on the front end so that the milli-voltmeter indicates maximum.
- e) Repeat procedures c) and d) two or three times.

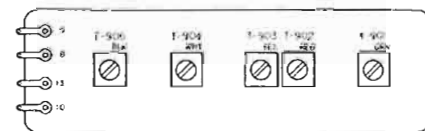

Fig. 15

## 6. DIAL MECHANISM ADJUSTMENT

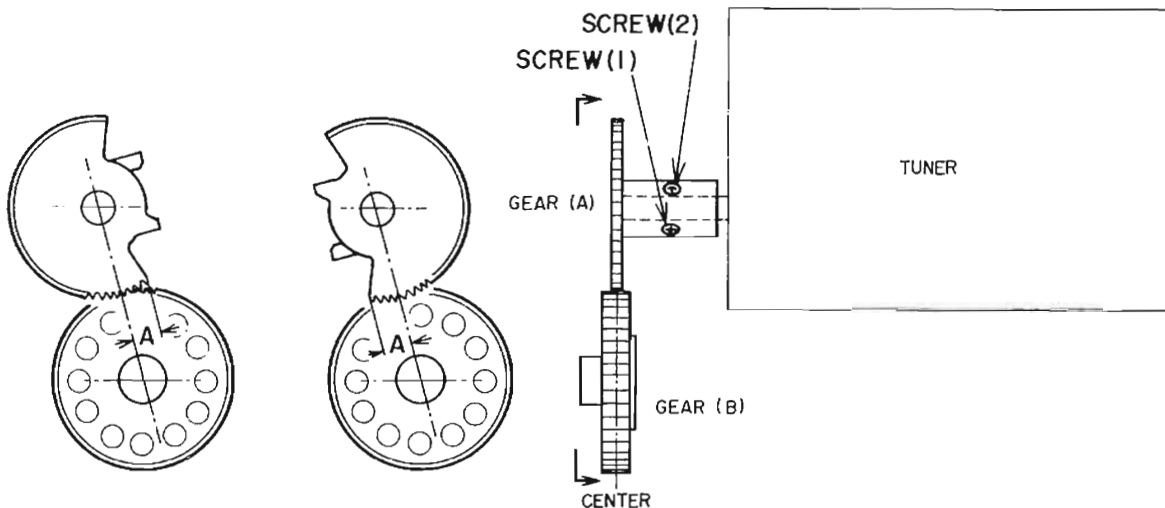

Fig. 16

- 1) Adjust Screws (1) and (2) so that as the dial is rotated from end to end, the teeth of the fan-shaped gear (last tooth on both ends) are symmetrical (left/right) and comes to the center of the meshing gear.

- 2) Adjustment is made with dial scale at extreme top position (knob turned to extreme left). Tighten screws (3) and (4) so that dial drum is in exact center of dial scale (Fig. 17) and at position where needle lines (right and left) are exactly aligned with horizontal line at middle of dial (as shown in Fig. 18).



## IV. TROUBLE SHOOTING CHART

### NO SOUND

Symptom	REMARKS	
Defective speaker system.	<ul style="list-style-type: none"> <li>• Speaker cables open or shorted.</li> <li>• Speaker voice coil open.</li> </ul>	<ul style="list-style-type: none"> <li>• Check speaker terminals for looseness.</li> <li>• Repair or replace speaker.</li> </ul>
No electrical supply.	<ul style="list-style-type: none"> <li>• Absence of power supply.</li> <li>• Defective power switch.</li> <li>• Line cord plug has faulty contact or is disconnected.</li> <li>• Line fuse blown.</li> </ul>	
Blown fuse upon replacement.	<ul style="list-style-type: none"> <li>• Short in power transformer.</li> <li>• Shorted diodes for D-101 to D-109.</li> <li>• Shorted electrolytic capacitors: C-103 to 107, C-109, 110, 116.</li> </ul>	<ul style="list-style-type: none"> <li>• Replace transformer.</li> <li>• Replace defective diodes.</li> <li>• Replace defective capacitors.</li> </ul>
Pilot lamp lights, but no sound from speaker.	<ul style="list-style-type: none"> <li>• Protection circuit in operation.</li> <li>• Speaker changeover switch at "PHONO".</li> <li>• "TAPE MONITOR" switch at "TAPE PLAY".</li> </ul>	<ul style="list-style-type: none"> <li>• Check speaker output terminals and leads for short.</li> <li>• Set to "A" or "B" position.</li> <li>• Set switch to "SOURCE".</li> </ul>
Internal Failure.	<ul style="list-style-type: none"> <li>• Inoperative B power source Circuit.</li> <li>• Fuses F-102 and F-103 (protecting power transistors) blown.</li> </ul>	<ul style="list-style-type: none"> <li>• Secondary winding in power transformer open. Resistors R-101 to R-105 open.</li> <li>• Shorted power transistors TR-206 to TR-209, TR-256 to TR-259.</li> </ul>
Sound from one channel only.	<ul style="list-style-type: none"> <li>• Improper position of balance control.</li> <li>• Defective channel audio circuit.</li> </ul>	<ul style="list-style-type: none"> <li>• Adjust balance control.</li> <li>• Check for defect by measuring voltages at check points, comparing them with normal channel.</li> </ul>

### LOW SOUND LEVEL

Symptom	REMARKS	
Low sound on both channels.	<ul style="list-style-type: none"> <li>• Defective power supply circuit.</li> </ul>	<ul style="list-style-type: none"> <li>• Check wiring and voltage.</li> </ul>
Low sound on the channel.	<ul style="list-style-type: none"> <li>• Defective speaker.</li> <li>• Discharged coupling capacitor.</li> </ul>	<ul style="list-style-type: none"> <li>• Replace Speaker.</li> <li>• Replace defective capacitor(s).</li> </ul>

### DISTORTION

Symptom	REMARKS	
Distorted sound on both channels.	<ul style="list-style-type: none"> <li>• Defective power supply circuit.</li> </ul>	<ul style="list-style-type: none"> <li>• Check AA-851.</li> </ul>
Distorted sound on one channel.	<ul style="list-style-type: none"> <li>• Defective speaker.</li> <li>• Leaky coupling capacitor(s).</li> <li>• Defective or unbalanced power transistors.</li> </ul>	<ul style="list-style-type: none"> <li>• Replace speaker.</li> <li>• Replace defective capacitor(s).</li> <li>• Adjust or replace.</li> </ul>

### HUM AND NOISE

Symptom	REMARKS	
Excessive hum.	<ul style="list-style-type: none"> <li>• Discharged capacitor in power supply circuit.</li> <li>• Defective rectifying diodes in power supply circuit.</li> <li>• Defective transistor in power supply filter circuit.</li> </ul>	<ul style="list-style-type: none"> <li>• Check C-104 to C-107, C-109, 110, 116.</li> <li>• Check D-101 to D-109.</li> <li>• Replace TR-101 or TR-102 for short.</li> </ul>

Symptom	REMARKS
Excessive noise.	<ul style="list-style-type: none"> <li>Defective transistor in pre-amplifier circuit.</li> <li>Defective volume control variable resistor.</li> </ul>
Inoperative loudness control.	<ul style="list-style-type: none"> <li>Defective loudness circuit AA-853.</li> </ul>
Inoperative tone control.	<ul style="list-style-type: none"> <li>At "TREBLE"</li> <li>At "BASS"</li> </ul>
	<ul style="list-style-type: none"> <li>Check TR-301, TR-351, TR-401 to TR-404, TR-451 to TR-454, TR-501, TR-502, TR-551 and TR-552.</li> <li>Check VR-403.</li> </ul>
	<ul style="list-style-type: none"> <li>Check C-301, 302, C-351, 352, R-301, 302, R-351, 352 and VR-403.</li> </ul>
	<ul style="list-style-type: none"> <li>Check C-408, 409, C-458, 459, R-411, 412, R-461, 462, R-415, 465, VR-402, 452.</li> <li>Check C-407, 457, C-416, 466, R-409, 459, R-410, 460, VR-401, 451.</li> </ul>

#### FM RECEPTION TROUBLE

Symptom	REMARKS
No FM reception.	<ul style="list-style-type: none"> <li>FM front-end, FM-IF or MPX circuit defective.</li> </ul>
Sound satisfactory but stereo indicator lamp not lit.	<ul style="list-style-type: none"> <li>Defective operation of stereo beacon circuit or defective lamp.</li> </ul>
Incomplete separation during FM reception.	<ul style="list-style-type: none"> <li>Defective FM multiplex circuit.</li> </ul>
Excessive noise.	<ul style="list-style-type: none"> <li>Weak broadcasting signal or weak input signal to amplifier.</li> </ul>
Intermittent noises.	<ul style="list-style-type: none"> <li>Due to automobile ignition noises.</li> </ul>
Noise increases during FM reception.	<ul style="list-style-type: none"> <li>Due to peculiar FM receiver noise when signal is very weak.</li> </ul>
Stereo indicator lamp always lit.	<ul style="list-style-type: none"> <li>Defective FM multiplex circuit.</li> </ul>
	<ul style="list-style-type: none"> <li>Check SELECTOR switch. Check voltage of IC-801, 802 and FLT-801.</li> <li>Check voltage of TR-604 to TR-608 printed board AA-856. Replace lamp if defective.</li> <li>Defective circuit of TR-601 to 603, TR-610 to 613 on printed board AA-856.</li> <li>Adjust VR-601 with measuring equipment or stereo FM wave.</li> </ul>
	<ul style="list-style-type: none"> <li>Orient or replace antenna with a higher gain. Antenna feeder open or loosely connected.</li> <li>Install FM antenna as far away from streets as possible.</li> <li>Set DISTANCE switch to ON. If sensitivity of FM receiver decreases, check or re-adjust FM-IF circuit.</li> </ul>
	<ul style="list-style-type: none"> <li>Defective transistor TR-607, 608.</li> </ul>

#### AM RECEPTION TROUBLE

Symptom	REMARKS
No AM reception.	<ul style="list-style-type: none"> <li>Defective AM IF circuit AA-859.</li> </ul>
Excessive Noise.	<ul style="list-style-type: none"> <li>Weak signal.</li> </ul>
Hum when tuned to broadcasting station.	<ul style="list-style-type: none"> <li>Due to transmission lines or generating noise of electrical apparatuses (e.g. fluorescent lamps, motors, etc.) nearby.</li> </ul>
Buzzing Noise.	<ul style="list-style-type: none"> <li>Due to a TV set nearby.</li> </ul>
	<ul style="list-style-type: none"> <li>Check voltage of TR-901 – TR-904. Check selector switch.</li> <li>Use external antenna.</li> <li>When bar antenna is used, reposition until noise is minimized. Reset AC cord plug.</li> <li>Relocate amplifier.</li> </ul>

#### WHEN EXTERNAL INPUT IS USED (Tape recorder, recorder, etc.)

Symptom	REMARKS
No sound or Increase of noise or Hum.	<ul style="list-style-type: none"> <li>Faulty connection.</li> </ul>
	<ul style="list-style-type: none"> <li>Check connections and polarity referring to operator's manual.</li> <li>Check selector switch.</li> </ul>

V. DISASSEMBLY / DIAL STRINGS

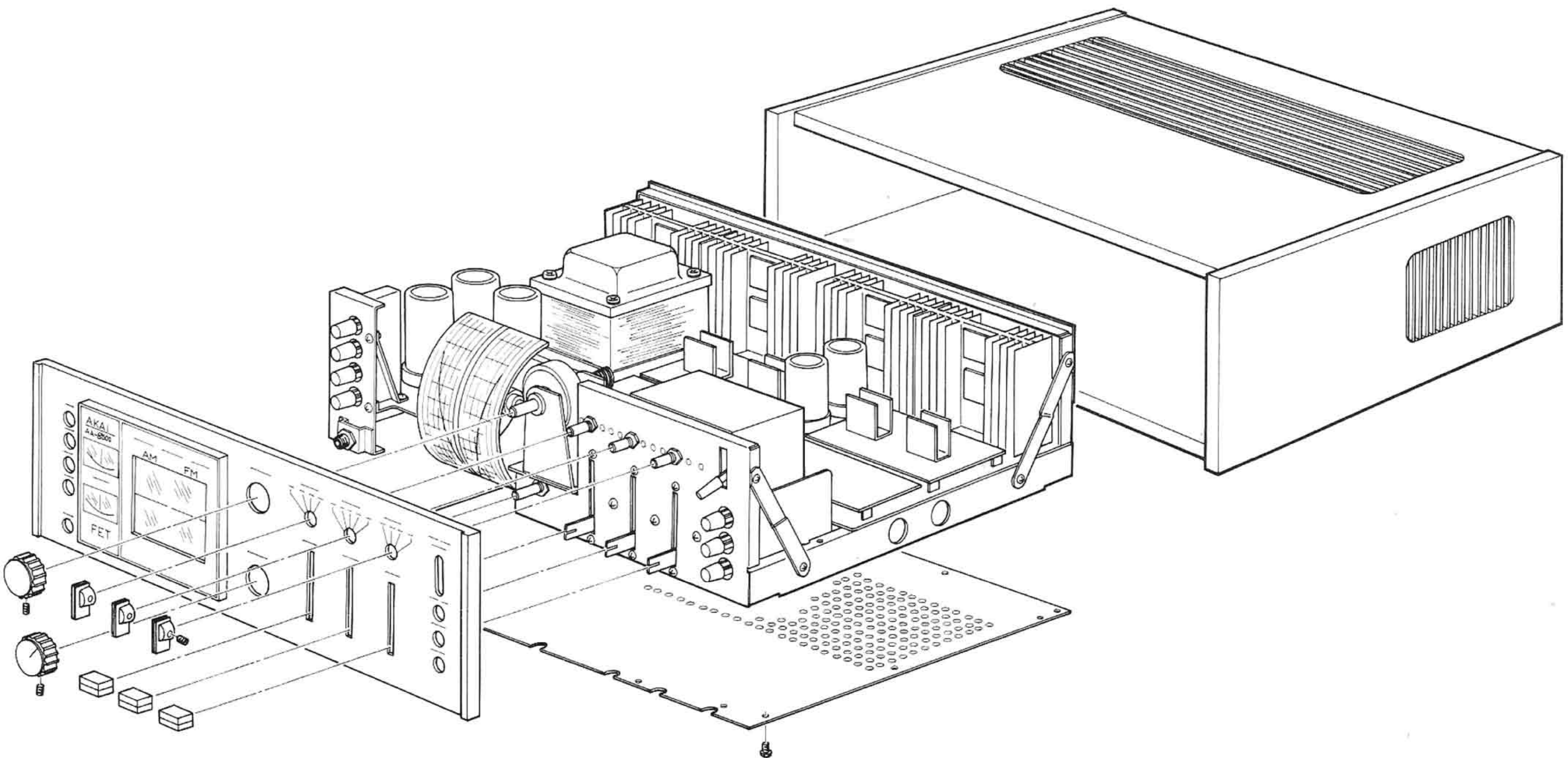

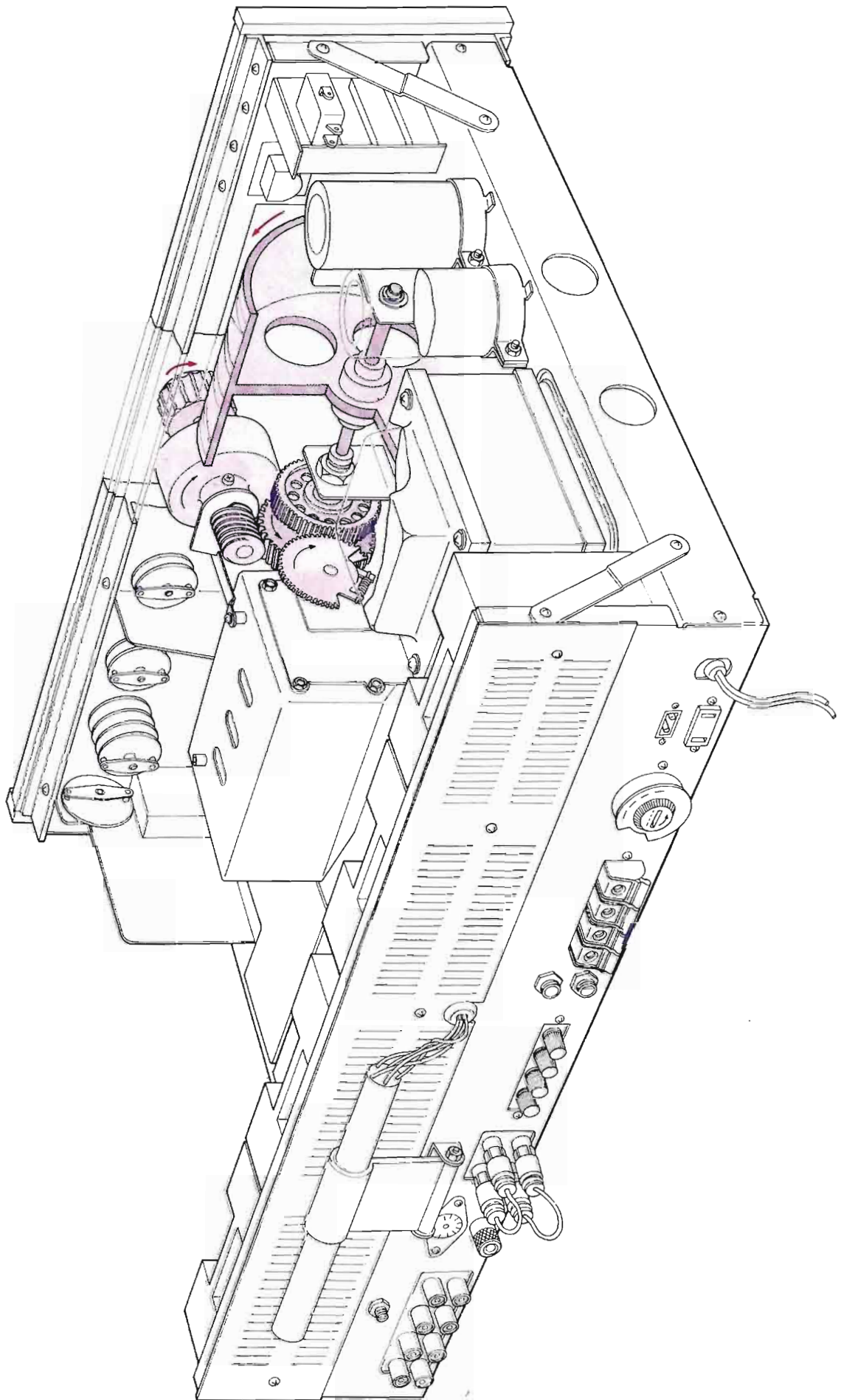



# VI. COMPOSITE VIEW OF COMPONENTS

## MAIN AMPLIFIER P.C. BOARD (AA-5539)

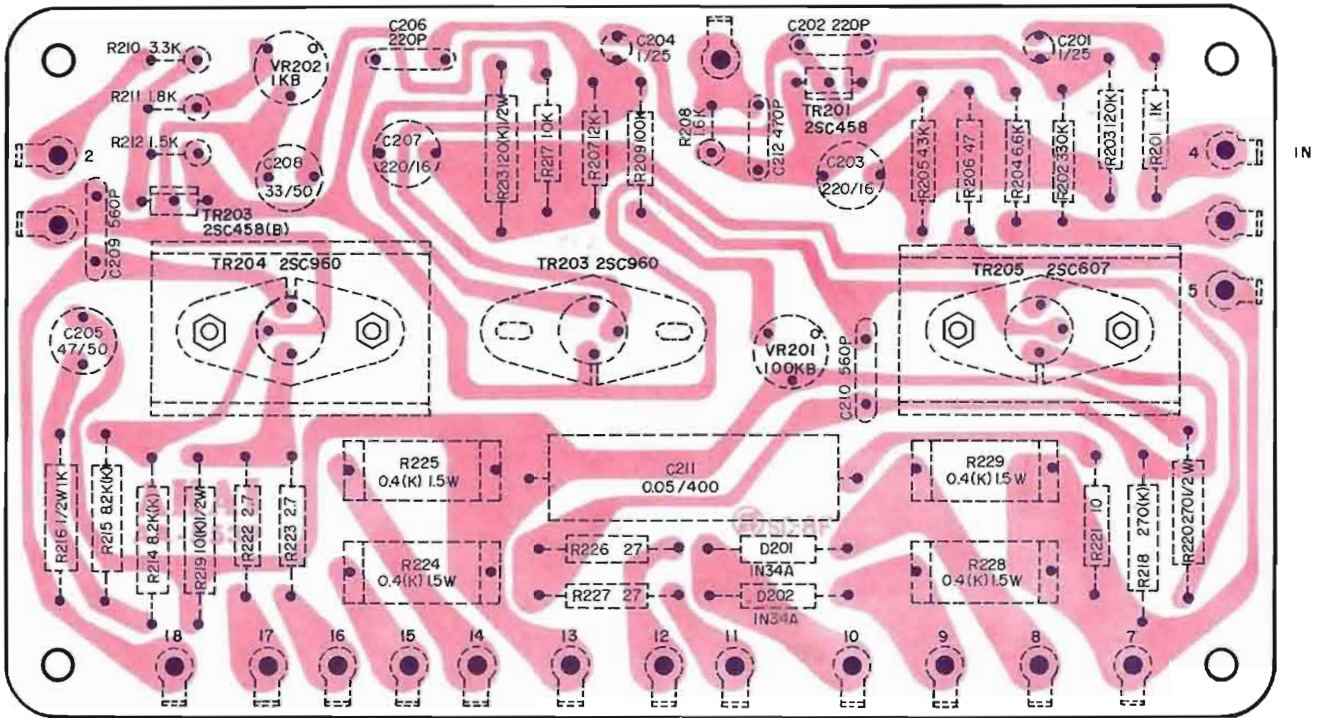

## PRE-AMPLIFIER P.C. BOARD (AA-5545)

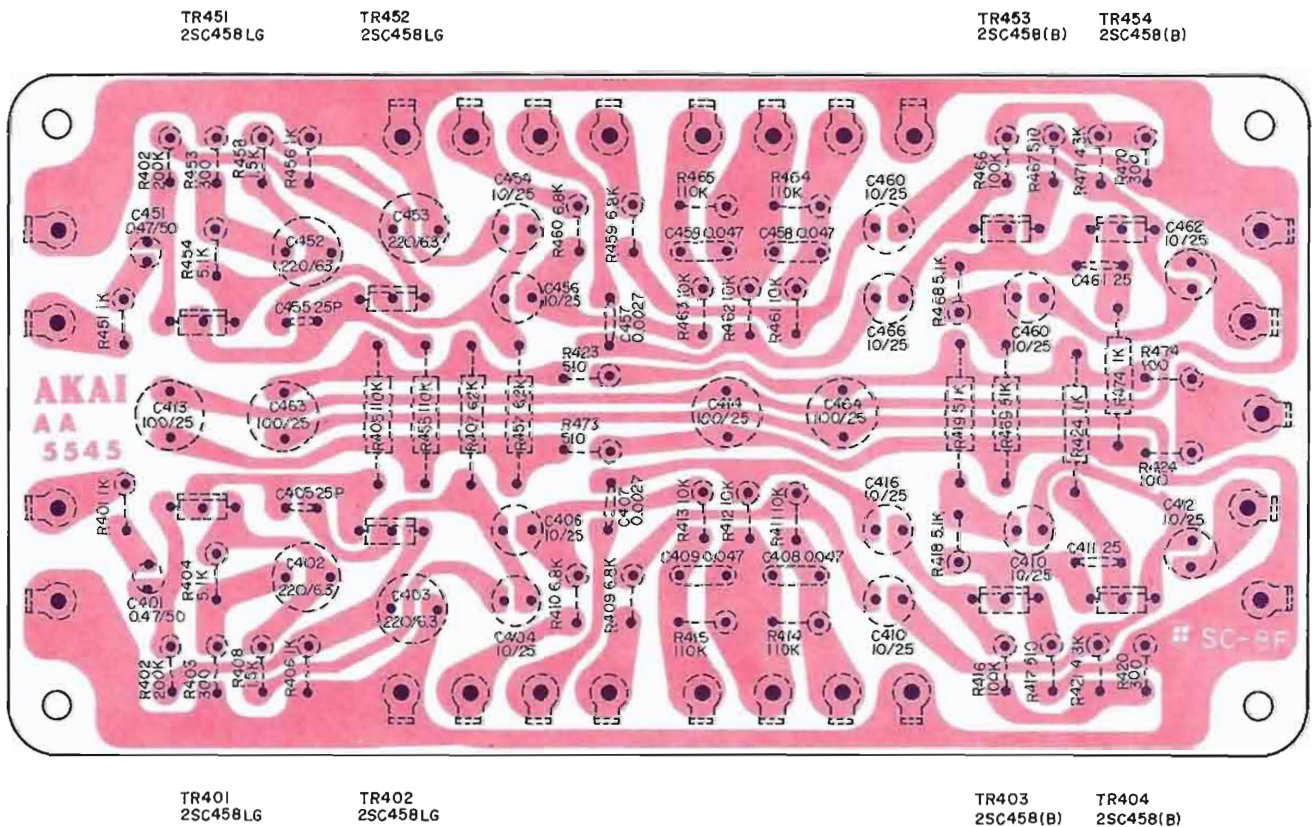

FM-IF P.C. BOARD (AA-5538)

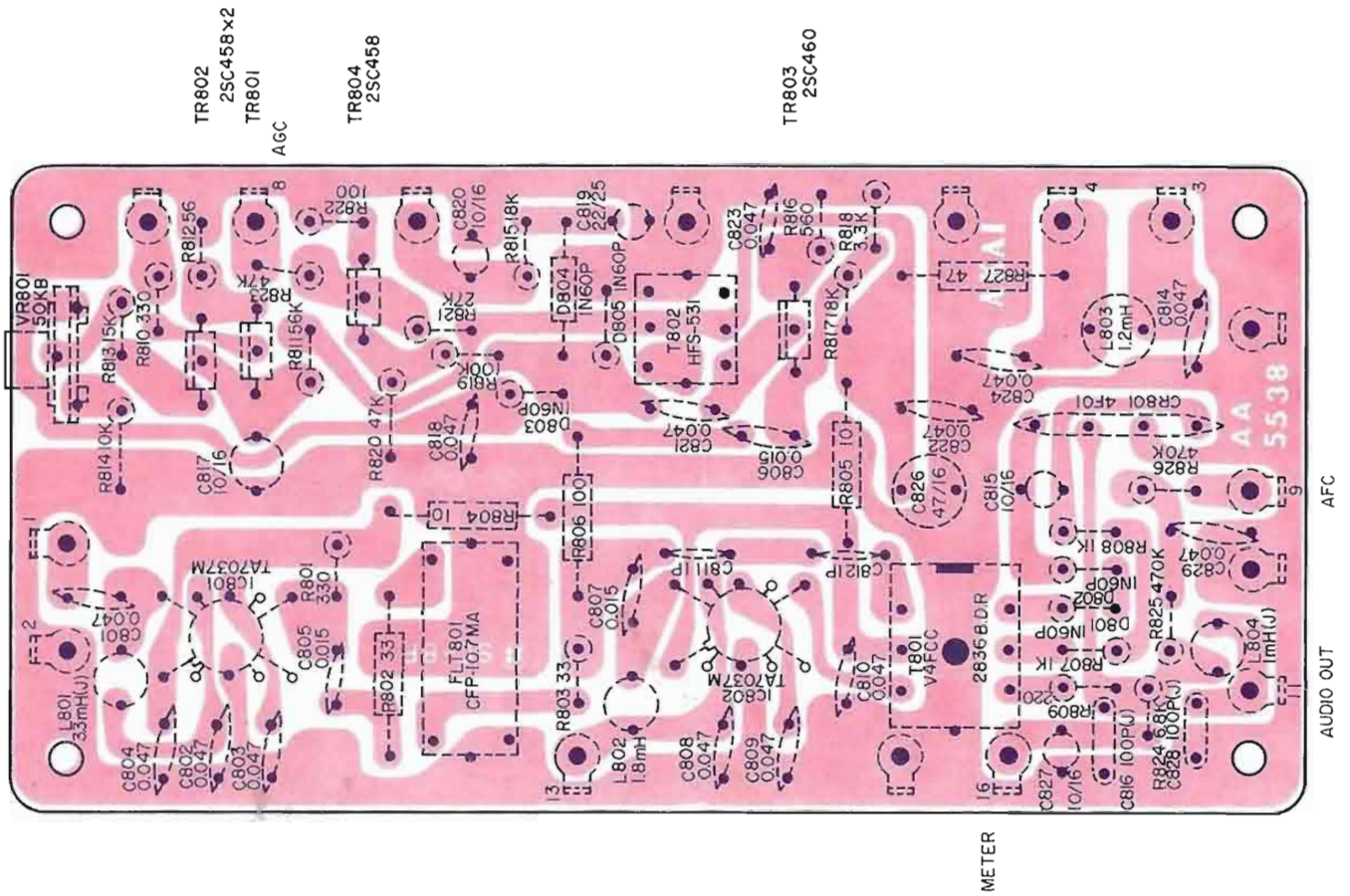

AM-IF P.C. BOARD (AA-5537)

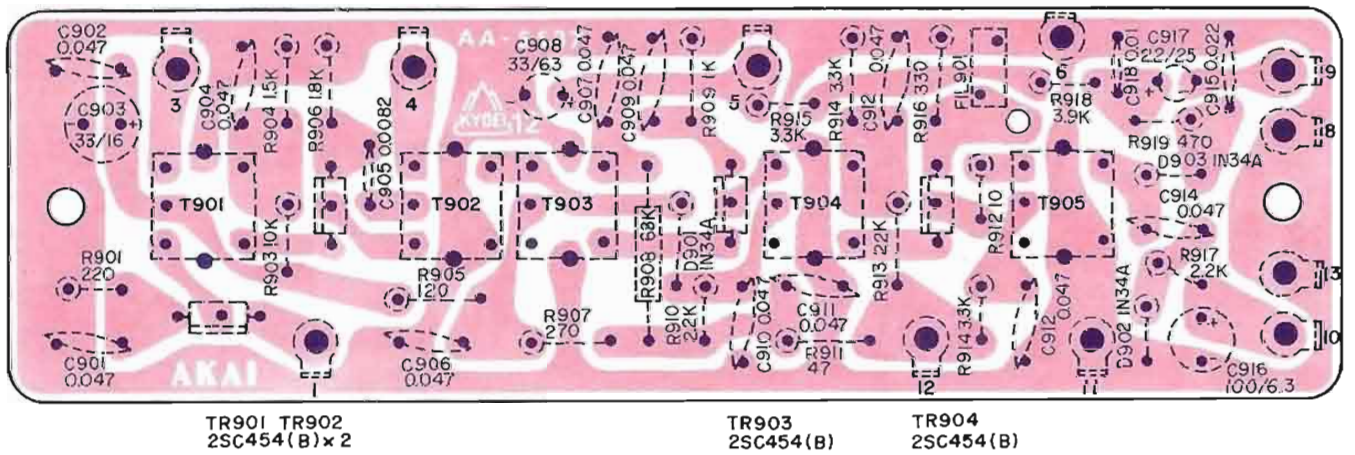

MPX P.C. BOARD (AA-5536)

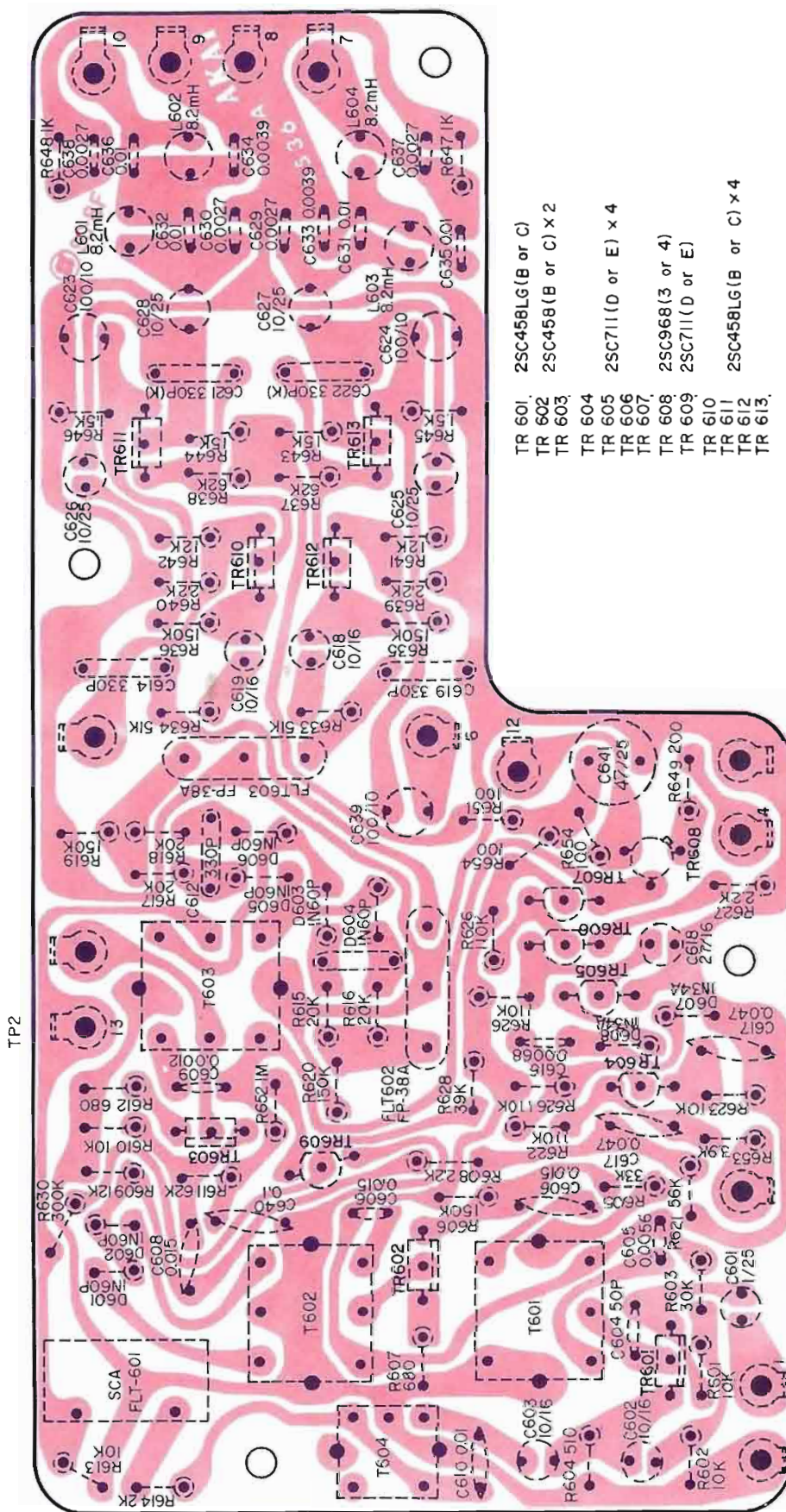

- TR 601, 2SC458LG(B or C)
- TR 602, 2SC458(B or C) x 2
- TR 603,
- TR 604,
- TR 605, 2SC711(D or E) x 4
- TR 606,
- TR 607,
- TR 608, 2SC968(3 or 4)
- TR 609, 2SC711(D or E)
- TR 610,
- TR 611,
- TR 612,
- TR 613, 2SC458LG(B or C) x 4

EQUALIZATION P.C. BOARD (AA-5546)

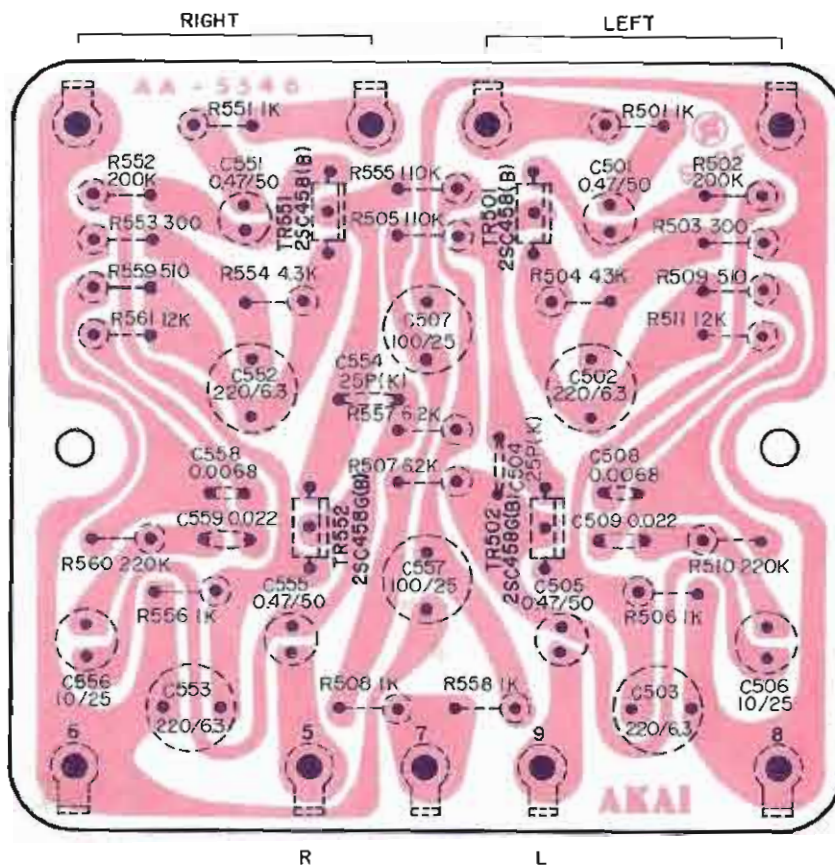

POWER SOURCE P.C. BOARD (AA-5547)

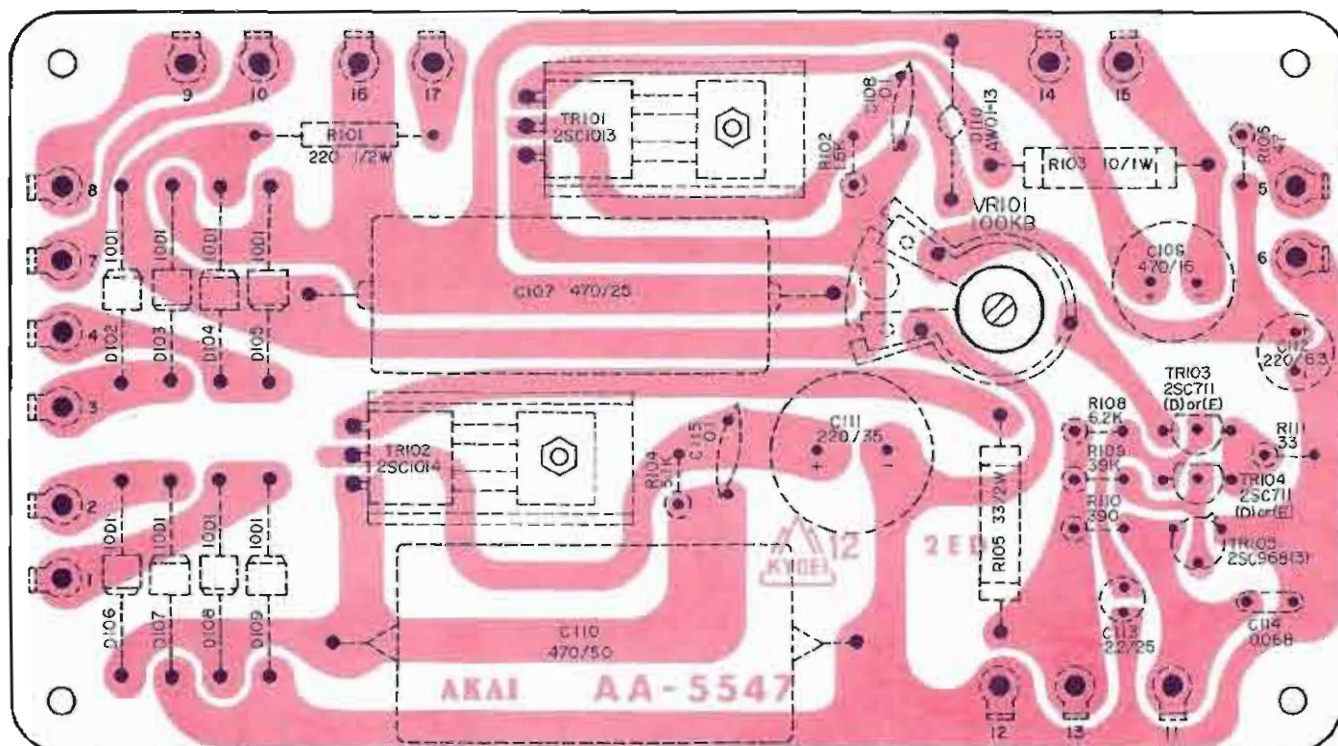

FILTER P.C. BOARD (AA-5532)

