

AKAI SERVICE MANUAL

AA-R22/L
AA-R32/L

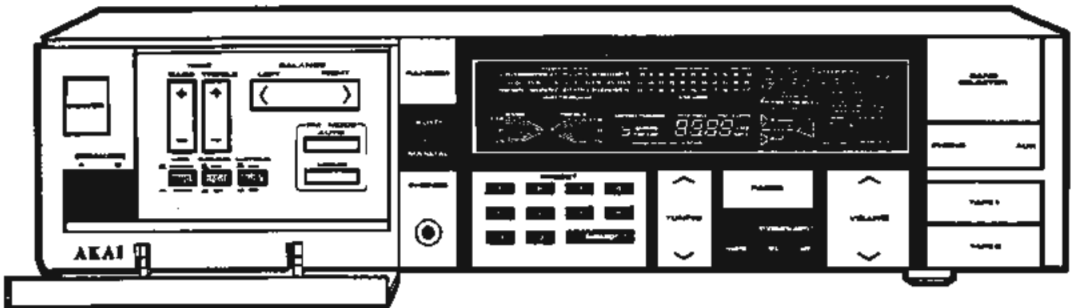
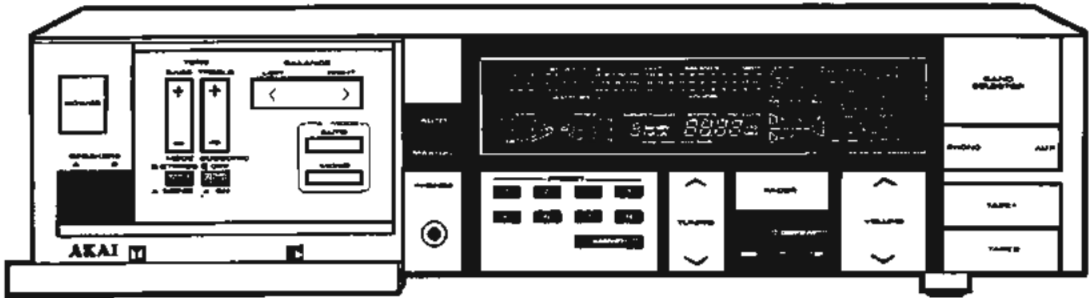
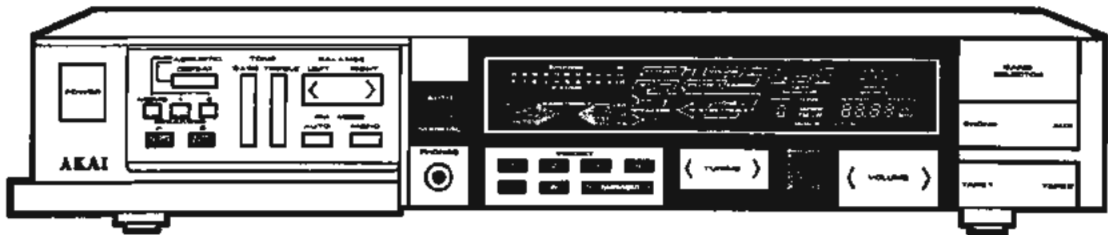

STEREO RECEIVER

MODEL **AA-R22/L**

MODEL **AA-R32/L**

MODEL **AA-R42**

ABBREVIATIONS FOR SERVICE MANUAL MODEL AA-R22/L, AA-R32/L, AA-R42

ABBREVIATION	EXPLANATION
A-SW	Analogue SWitch
CK	ClocK
C-MOS	Complementary Metal Oxide Semi-conductor
CPU	Central Processor Unit
f_L	Local oscillator Frequency divided by PLL factor
FLD	Fluorescent Display
f_R	Reference Frequency divided by PLL factor
GND	GrouND
H	High (referring to voltages)
INT	INTerrupt (terminal)
L	Left
L	Low (referring to voltages)
LD	Lock out Detection terminal
LPF	Low Pass Filter
LSB	Least Significant Bit
MSB	Most Significant Bit
NC	Not Connected
PIN	Programmable counter INput terminal
PLL	Phase Lock Loop
POUT	Programmable counter OUTput terminal
R	Right
ST	STrobe
SW	SWitch
SEG	SEGment
VCO	Voltage Controlled Oscillator
XT	Crystal controlled connection Terminal

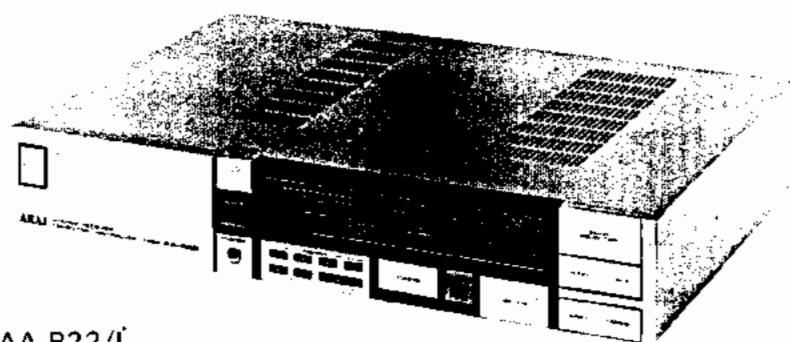

AA-R22/L

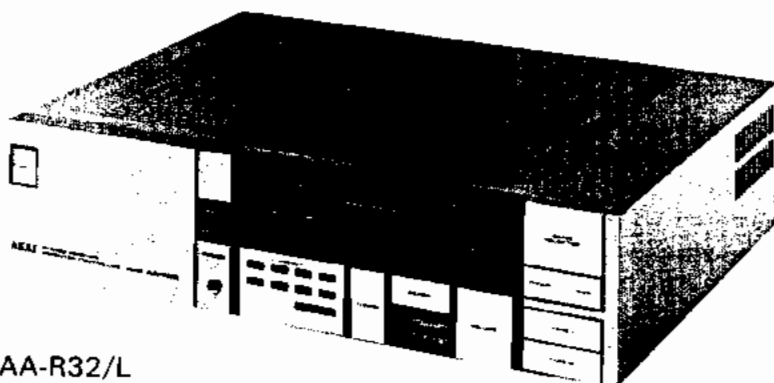

AA-R32/L

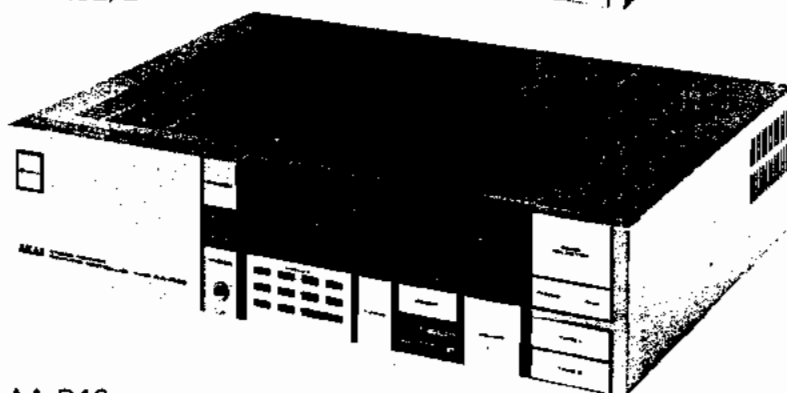

AA-R42

STEREO RECEIVER

MODEL **AA-R22/L**

MODEL **AA-R32/L**

MODEL **AA-R42**

THIS MANUAL IS APPLICABLE TO BOTH SILVER
AND PEARL SHADOW PANEL MODELS

SECTION 1	CIRCUIT OPERATION DESCRIPTION	1
SECTION 2	MODEL AA-R22/L SERVICE MANUAL	33
SECTION 3	MODEL AA-R32/L, AA-R42 SERVICE MANUAL	47
SECTION 4	PARTS LIST	75
SECTION 5	SCHEMATIC DIAGRAM	98

SAFETY INSTRUCTIONS

SAFETY CHECK AFTER SERVICING

Confirm the specified insulation resistance between power cord plug prongs and externally exposed parts of the set is greater than 10 Mohms, but for equipment with external antenna terminals (tuner, receiver, etc.) and is intended for **C** or **A**, specified insulation resistance should be more than 2.2 Mohms (ground terminals, microphone jacks, headphone jacks, line-in-out jacks etc.)

PRECAUTIONS DURING SERVICING

1. Parts identified by the Δ symbol parts are critical for safety.
Replace only with parts number specified.
2. In addition to safety, other parts and assemblies are specified for conformance with such regulations as those applying to spurious radiation. These must also be replaced only with specified replacements.
Examples: RF converters, tuner units, antenna selector switches, RF cables, noise blocking capacitors, noise blocking filters, etc.
3. Use specified internal wiring. Note especially:
 - 1) Wires covered with PVC tubing
 - 2) Double insulated wires
 - 3) High voltage leads
4. Use specified insulating materials for hazardous live parts. Note especially:
 - 1) Insulation Tape
 - 2) PVC tubing
 - 3) Spacers (Insulating Barriers)
 - 4) Insulation sheets for transistors
 - 5) Plastic screws for fixing microswitch (especially in turntable)
5. When replacing AC primary side components (transformers, power cords, noise blocking capacitors, etc.), wrap ends of wires securely about the terminals before soldering.

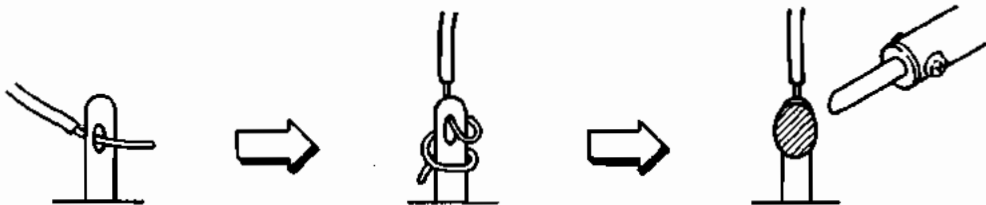

6. Observe that wires do not contact heat producing parts (heatsinks, oxide metal film resistors, fusible resistors, etc.).
 7. Check that replaced wires do not contact sharp edged or pointed parts.
 8. Also check areas surrounding repaired locations.
 9. Use care that foreign objects (screws, solder droplets, etc.) do not remain inside the set.
-

SECTION 1

CIRCUIT OPERATION DESCRIPTION

TABLE OF CONTENTS

I.	OUTLINE OF AA-R SERIES SYSTEM	2
	1. ACCEPTANCE OF INPUT SELECTOR DATA	2
	2. FL DISPLAY	2
	3. SELECTION OF INPUT SIGNAL	2
	4. VOLUME CONTROL	2
	5. TONE CONTROL	2
	6. LONG-TIME BACK-UP BY CAPACITOR	2
II.	OPERATION OF AMPLIFIER SECTION CONTROL	
	IC AA-100 PERIPHERAL CIRCUIT	3
	1. AA-100 PERIPHERAL BLOCK DIAGRAM	3
	2. AA100 TERMINALS DESCRIPTION	5
	3. DISPLAY DATA	6
	4. DIGIT OUTPUT OF AA-100	7
	5. DESCRIPTION OF INPUT SELECTOR	8
	6. OPERATION OF ELECTRONIC VOLUME CONTROL	
	AND TONE CONTROL	10
	7. THE STATUS THAT WILL BE ESTABLISHED WHEN	
	WHEN RESET BUTTON IS PRESSED	17
	8. RESET STATUS WHEN POWER IS ON	17
	9. HOW TO MAKE LETTERS	18
III.	OPERATION OF TUNER SECTION CONTROL	
	IC AT-600 PERIPHERAL CIRCUIT	20
	1. BLOCK DIAGRAM OF AT-600 PERIPHERAL	20
	2. AT600 TERMINALS DESCRIPTION	22
	3. KEY MATRIX AND TIMING CHART OF SIGNAL FOR	
	DISPLAY SELECTION BLANK PERIOD	23
	4. FREQUENCY DISPLAY SEGMENT DATA	23
	5. BLOCK DIAGRAM OF PLL IC TC9125P INTERIOR AND	
	DESCRIPTION OF THE FUNCTION OF EACH TERMINAL	24
	6. PLL DATA FOR PLL IC (TC9125P) CONTROL	25
	7. FREQUENCY CONTROL BY PLL	27
IV.	AKAI ZERO DRIVE CIRCUIT (AA-R42/R32)	28
	1. IN THE BEGINNING	28
	2. PRINCIPLE OF AKAI ZERO DRIVE CIRCUIT	28
V.	DUAL-POLE DC SERVO (AA-R42/R32/R22)	31

I. OUTLINE OF AA-R SERIES SYSTEM

The AA-R series contains two chips, a micro-computer (AA-100) for the amplifier section and a micro-computer (AT-600) for the tuner section. They control the

system operations. All controls such as input select, volume, tone control, tuner, etc. which have been done mechanically so far are now done electronically.

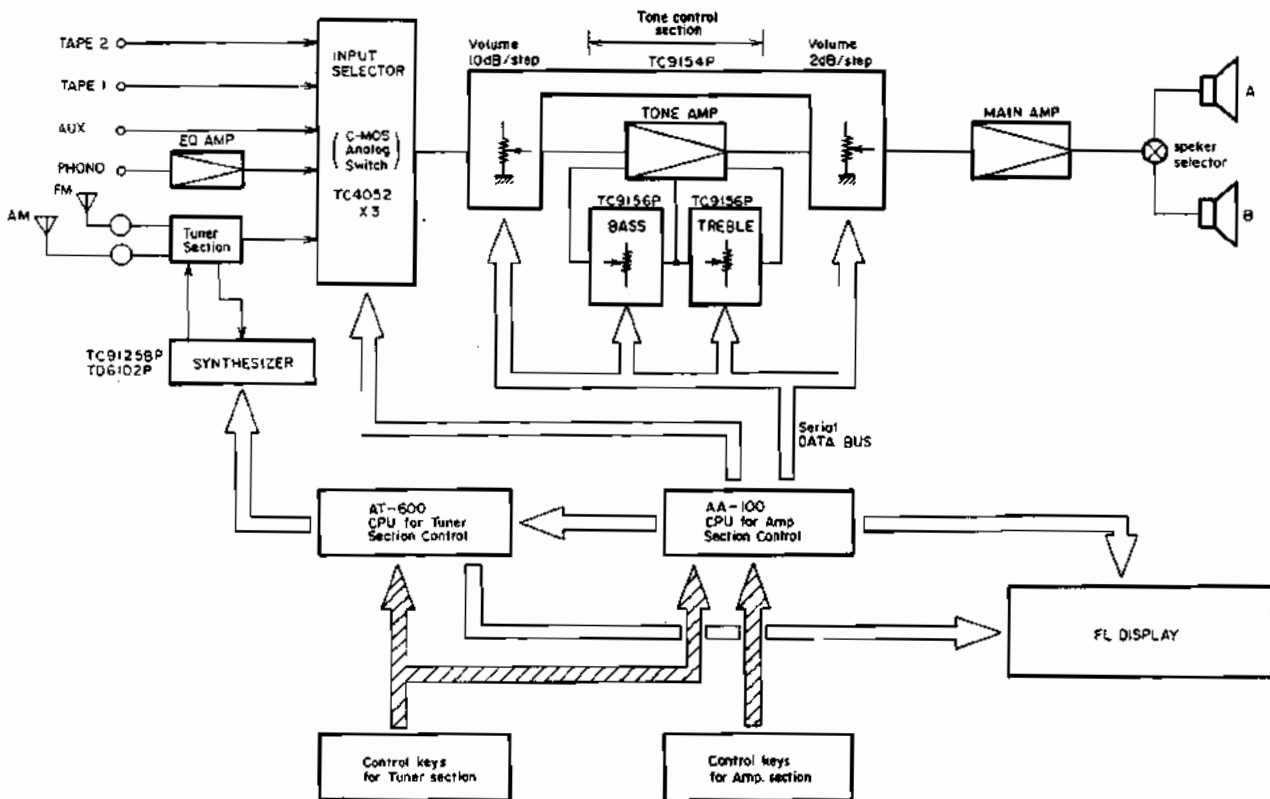

Fig. 1-1 AA-R Series System Block Diagram

1. ACCEPTANCE OF INPUT SELECTOR DATA

The amplifier section input selection is in charge of AA-100 and the tuner section input selector is in charge of AT-600, but the band selector also acts as a function selector for input signal switching, and is in charge of AA-100 which controls AT-600 in order to stop all the operations of the tuner section for functions other than tuner and to extinguish the display.

2. FL DISPLAY

The amplifier-related display and the tuner-related display consist of dynamic lighting of duty 1/6 provided by AA-100 and AT-600 respectively.

3. SELECTION OF INPUT SIGNAL

In accordance with the buttons, PHONO, BAND, AUX, TAPE 1 and TAPE 2, AA-100 controls the C-MOS analog switch (TC4052x3) to select the appropriate analog signal.

4. VOLUME CONTROL

AA-100 transfers serially the level data corresponding to the UP or DOWN action to the volume IC to change the volume level.

5. TONE CONTROL

AA-100 transfers serially the data corresponding to the + or - action of the BASS and TREBLE to the bass or treble IC to change the step.

Since the serial data include the data for chip selection, the data transfer bus to the volume IC, bass IC or treble IC uses in common 3 bus bars, DATA, CLOCK and STROB.

6. LONG-TERM BACK-UP BY CAPACITOR

AA-100 and AT-600, micro-computers for CMOS processing, have very low current consumption in hold mode, thus enabling long-term back-up by a capacitor to be realized.

This provides the last-setting memory which maintains the prior status when the power is OFF. However the volume position will be reset at -26 dB in order to protect the speaker, even if the power went off at a volume level higher than the prescribed level of -26 dB.

II. OPERATION OF AMPLIFIER SECTION CONTROL IC AA-100 PERIPHERAL CIRCUIT

1. AA-100 PERIPHERAL BLOCK DIAGRAM

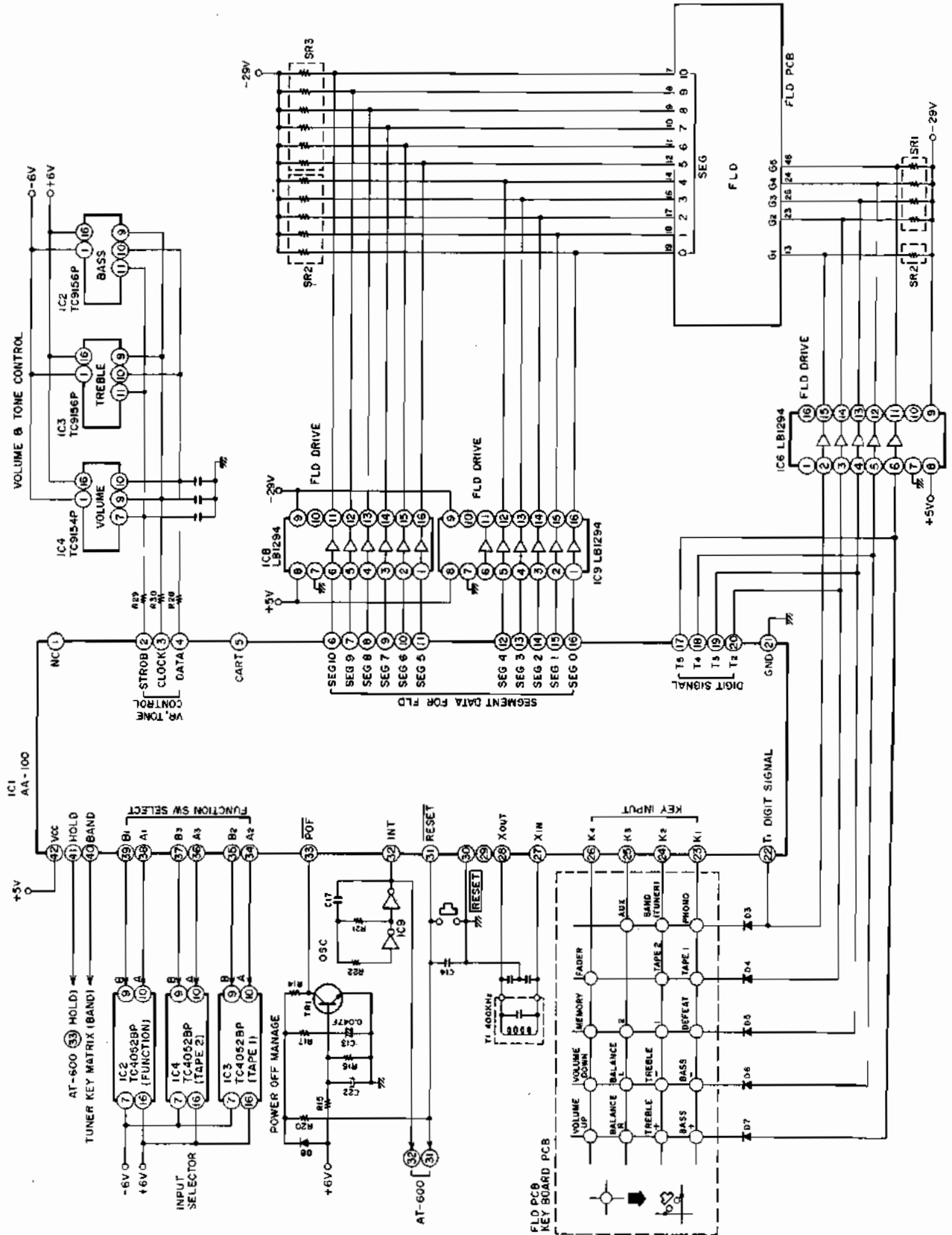

Fig. 1-2 AA-100 Peripheral Block Diagram (A1-R.22/L)

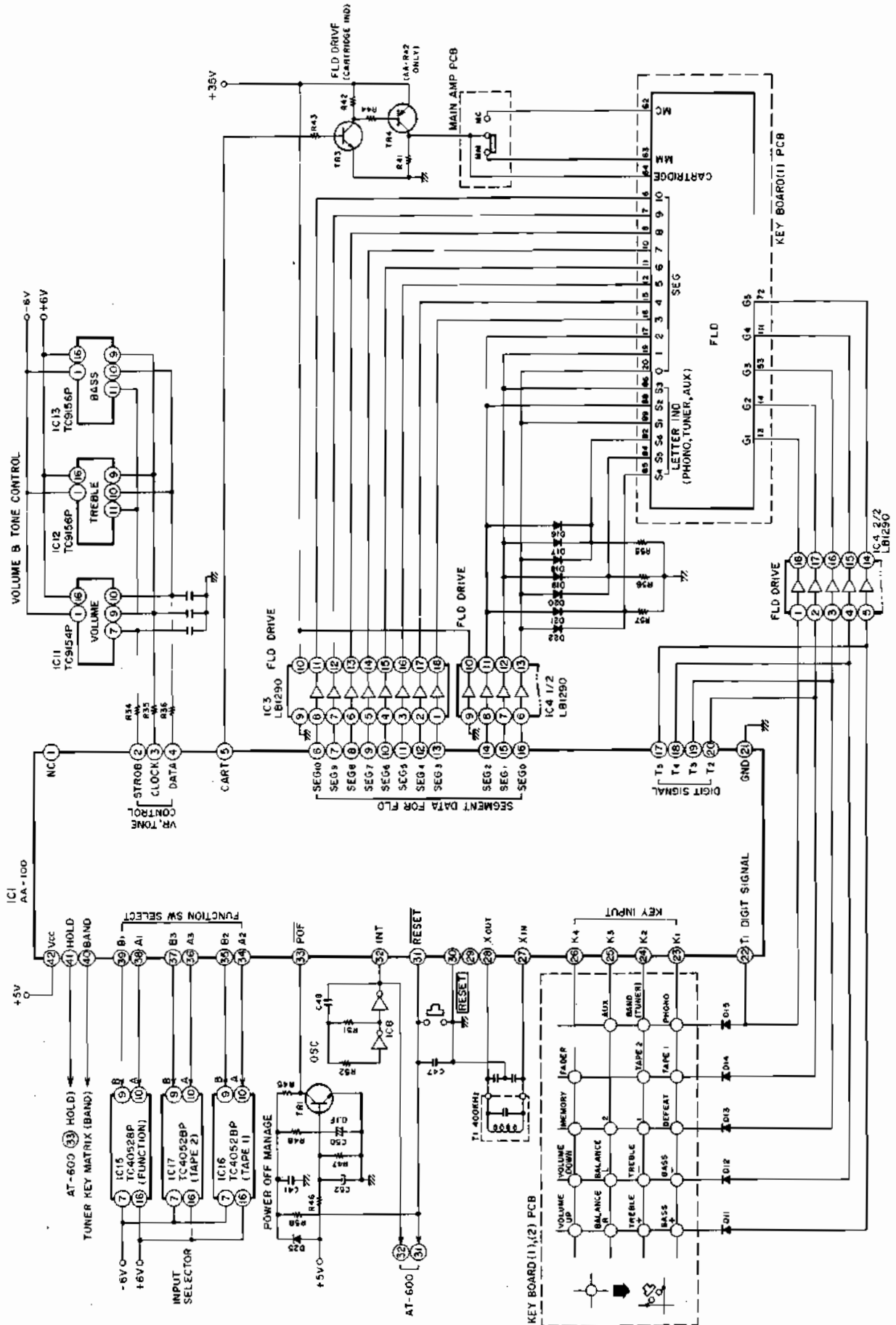

Fig. 1-3 AA-100 Peripheral Block Diagram (AA-R32/L, 42)

2. AA100 TERMINALS DESCRIPTION

No.	Terminal Description	Function
1	NC	
2	STROB	Output Control Signal for Elect. VR and TONE Output at ACTIVE "H"
3	CLOCK	
4	DATA	
5	CART (SEG11)	Output "H" when phono
6	SEG10	SEGMENT DATA for Display Output at ACTIVE "H"
7	SEG9	
8	SEG8	
9	SEG7	
10	SEG6	
11	SEG5	
12	SEG4	
13	SEG3	
14	SEG2	
15	SEG1	
16	SEG0	
17	T5	DIGIT Signal Output at ACTIVE "H"
18	T4	
19	T3	
20	T2	
21	GND	
22	T1	DIGIT Signal
23	K1	KEY Input Input at ACTIVE "H"
24	K2	
25	K3	
26	K4	
27	XIN	Clock OSC Coil
28	XOUT	
29	CK	unused
30	TEST	unused
31	RESET	Reset at ACTIVE "L"
32	INT	Interrupt Signal
33	POF	Power OFF at ACTIVE "H"
34	A2	FUNCTION SW Select Signal (B1, A1) TUNER, PHONO, AUX (B2, A2) Tape 1 (B3, A3) Tape 2 Output at ACTIVE "H"
35	B2	
36	A3	
37	B3	
38	A1	
39	B1	
40	BAND	
41	HOLD	Output "H" for HOLD of AT600
42	VCC	+5V

3. DISPLAY DATA

Segment data output (example: SEG 10 output when VOLUME 10, TREBLE 10 and BASS 10 are lit)

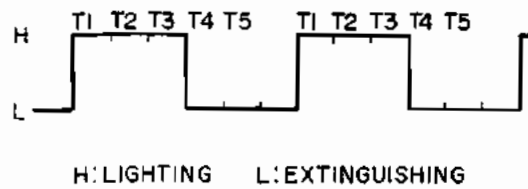

Segment Data	Digit Signal		T5 (Grid 5)	T4 (Grid 4)	T3 (Grid 3)	T2 (Grid 2)	T1 (Grid 1)
	Pin No.	Pin No.	17	18	19	20	22
SEG 11	5						
SEG 10	6				VOLUME 10	TREBLE +10	BASS +10
SEG 9	7			BALANCE	VOLUME 9	TREBLE +8	BASS +8
SEG 8	8		FADER	VOLUME	VOLUME 8	TREBLE +6	BASS +6
SEG 7	9		① ②	VOLUME 7	M2	TREBLE +4	BASS +4
SEG 6	10			VOLUME 6	M1	TREBLE +2	BASS +2
SEG 5	11		DUB 2 ← 1 ①	VOLUME 5	Frame of ACOUSTIC		
SEG 4	12			VOLUME 4	ACOUSTIC	TREBLE -2	BASS -2
SEG 3	13			VOLUME 3		TREBLE -4	BASS -4
SEG 2	14		AUX	VOLUME 2		TREBLE -6	BASS -6
SEG 1	15		TUNER	VOLUME 1	PASS LINE	TREBLE -8	BASS -8
SEG 0	16		PHONO	VOLUME 0	BALANCE	TREBLE -10	BASS -10

4. DIGIT OUTPUT OF AA-100

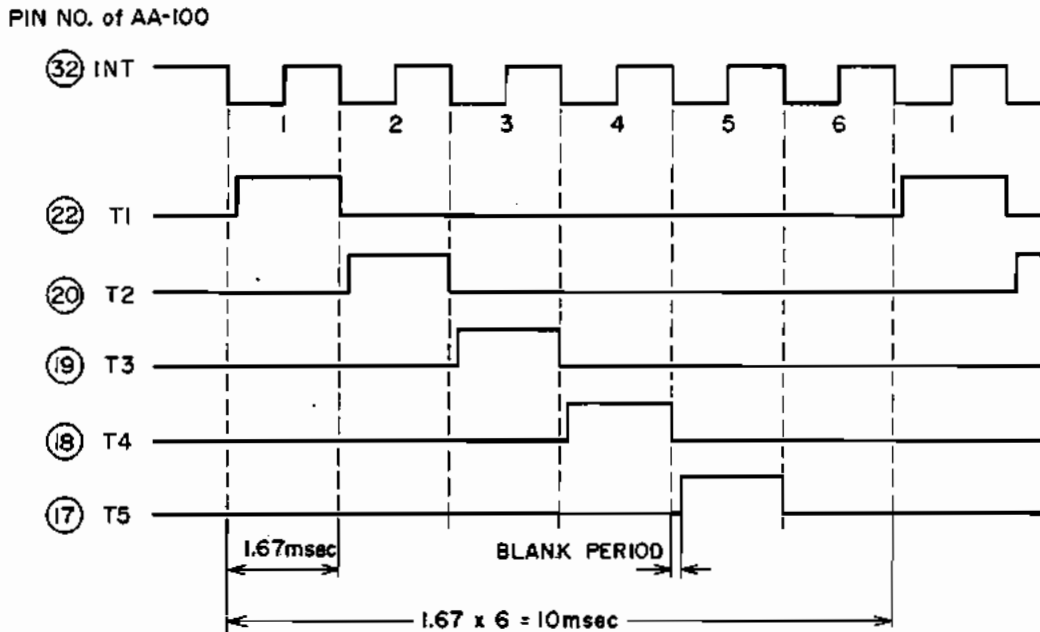

Fig. 1-4 Digit Output Timing Chart

Interrupt request is made at the repetition rate of 1.67 msec by the gate oscillator connected to the INT terminal and interrupt processing is carried out. Synchronized with this interrupt, digit output with the timing as shown in Fig. 1-4 is obtained at T1 to T5.

With the interrupts of 1.67 msec each, the digit data of 1 is output for one bit only in the set T1 to T5, and this is repeated 5 times. Then, every bit is provided with one 0 section, and then this cycle of 6 interrupts in total is repeated.

All the digits of key reading and dynamic fluorescent display are specified by this digit data.

All the 0 sections are provided at the 6th section in order to match the display duty cycle of the tuner micro-computer AT-600, and no display or key reading is available at this section. (AA-100 has only T1 to T5 while AT-600 has T1 to T6, and therefore, one dummy section without output is provided to meet the AT-600 duty cycle.)

5. DESCRIPTION OF INPUT SELECTOR

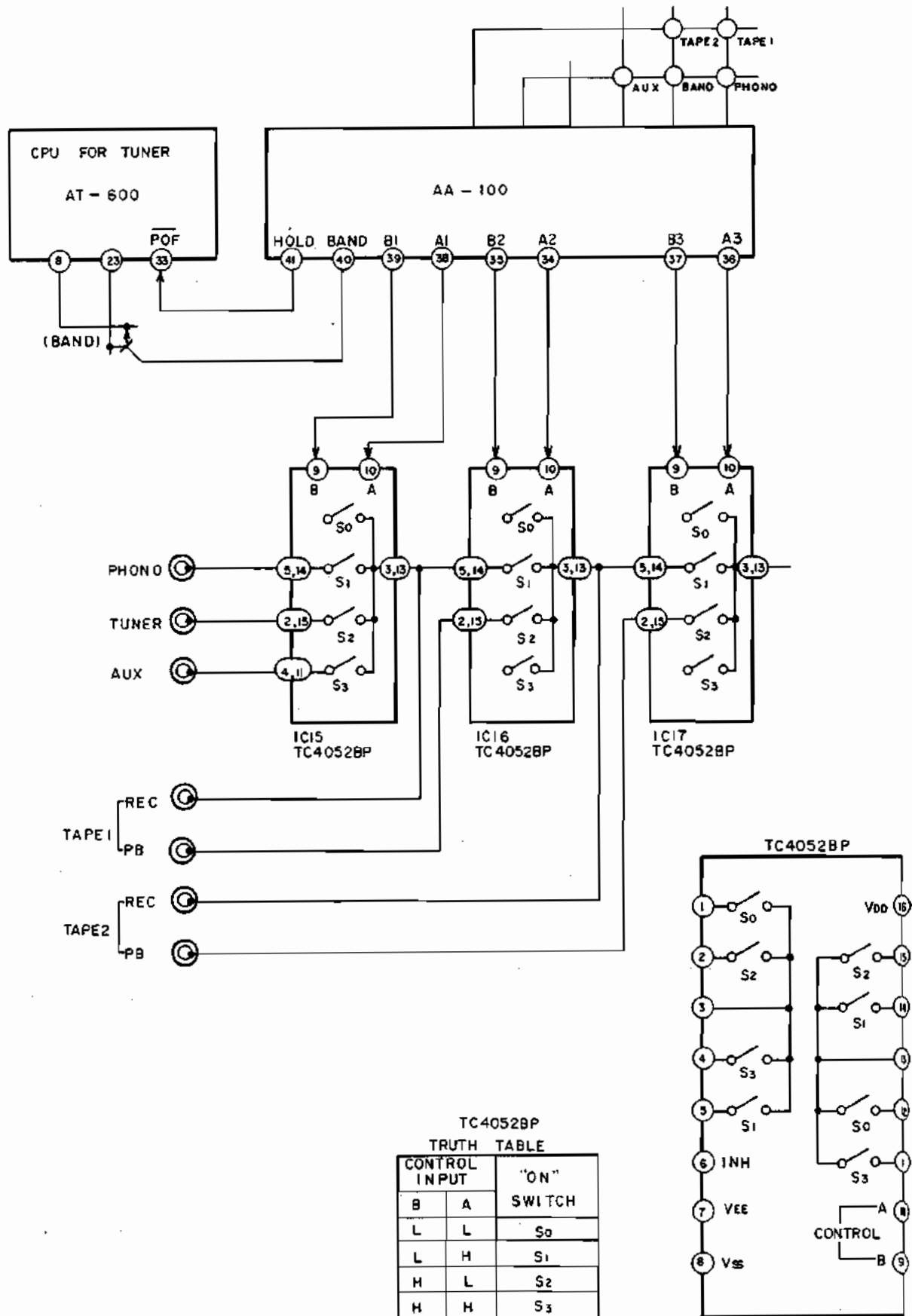

Fig. 1-5 Block Diagram of Input Switching Section

5-1. FUNCTION SWITCHING

KEY	④① HOLD	④② BAND	③⑨ B1	③⑧ A1
PHONO	H	L	L	H
BAND	L	L	H	L
AUX	H	L	H	H

Fig. 1-6 Output Data of AA-100 Pin ③⑧ to ④①

Fig. 1-6 shows the data output from PINS ③⑧ to ④① of AA-100 when each function key is pressed. This data is output when the status prior to the key operation is available in other function. When the PHONO key is pressed, "H" is applied to A of the analog switch TC4052BP and "L" to B, S1 is turned ON and the phono signal is selected. Similarly, when the BAND SELECTOR key is pressed, "L" is applied to A and "H" to B, and S2 is turned ON, and when the AUX key is pressed, "H" is applied to both A and B, S3 is turned ON, and the respective signal is selected. In the case of PHONO and AUX, "H" is output from HOLD (PIN ④①), and therefore, the tuner CPU AT-600 is put in hold mode and the tuner operation is stopped.

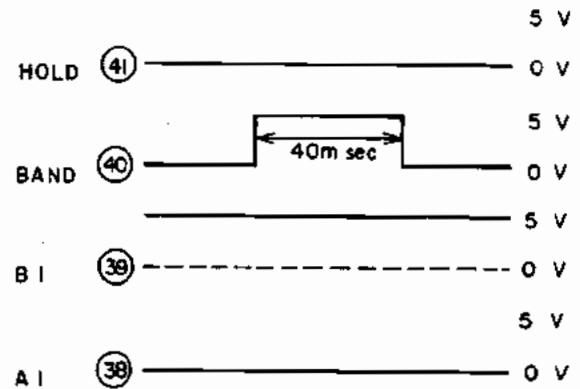

Fig. 1-7 Output Data of AA-100 Pin ③⑧ to ④① (When press the BAND key)

If the same function key is pressed a second time, no change occurs in the output of Pins ③⑧ to ④① of AA-100, except that if the BAND SELECTOR key is pressed repeatedly in tuner mode, the pulse of 40 msec is output at Pin ④② while the S2 (switch for tuner) ON data remains unchanged at Pins ③⑧ and ③⑨ as shown in Fig. 1-7. That is, it will turn ON the BAND SELECTOR key equivalent of the tuner key matrix and the band is switched in the sequence ... FM, LW, MW, FM ...

5-2. TAPE MONITOR SWITCHING

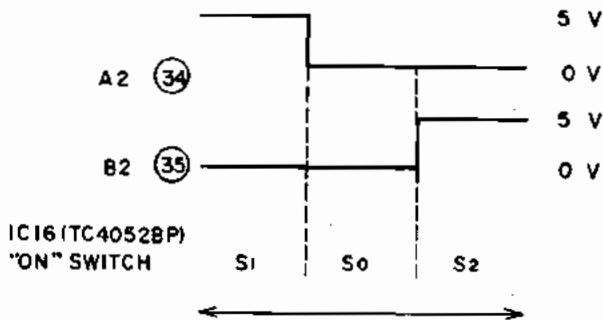

Fig. 1-8 Output of AA-100 Pin ③④, ③⑤ (TAPE 1)

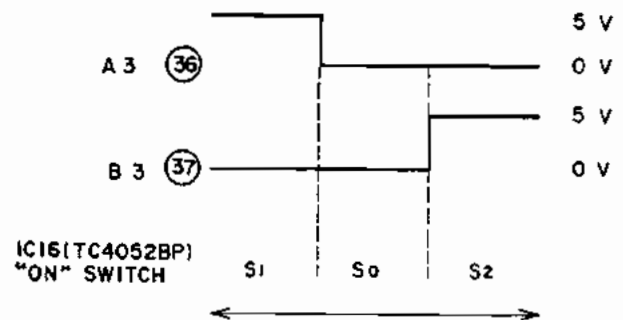

Fig. 1-9 Output of AA-100 Pin ③⑥, ③⑦ (TAPE 2)

Fig. 1-8 and Fig. 1-9 show the output of A and B and the operation switch timing chart of the analog switches IC16 and 17 (TC4052BP) when TAPE 1 or TAPE 2 keys are pressed.

In both cases, the control data sections of A = "L" and B = "L" are provided to operate the dummy switch S₀ so that no oscillating loop due to the short-circuit of the REC and PB lines can be created.

6. OPERATION OF ELECTRONIC VOLUME CONTROL AND TONE CONTROL

6-1. OPERATION OF ELECTRONIC VOLUME CONTROL

AA-100 has been given the functions of controlling the electronic volume and electronic tone control ICs. VOLUME, BASS and TREBLE control ICs are controlled by the serial data from Pins ② to ④ of AA-100. There are 3 data bits: DATA, CLOCK and STROB. The data bit includes the codes, C₀, C₁ and C₂, for chip selection, and by connecting the terminal of C₀, C₁ or C₂, "L" to (-) and "H" to (+), at each control IC, reception or non-reception of incoming serial data can be selected. For the VOLUME IC, all

the codes are specified as "0". In this system, the following codes are set for BASS and TREBLE.

	C ₀ ⑤	C ₁ ⑥	C ₂ ⑦
BASS	L	H	L
TREBLE	H	L	L

Fig. 1-10 Chip select Codes for BASS and TREBLE ICs (TC9156P)

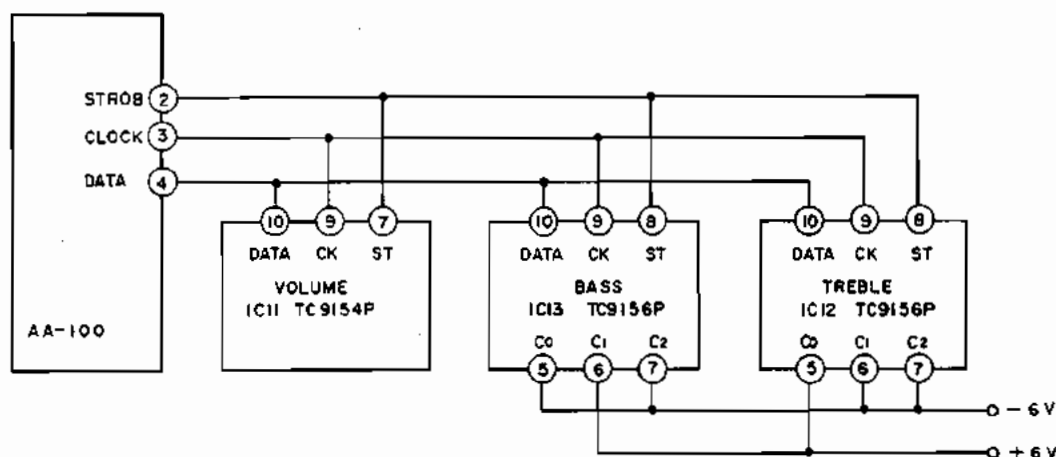

Fig. 1-11 Electronic volume and tone control

6-2. SERIAL TRANSFER DATA

VOLUME	-0	-10	-20	-30	-40	-50	-60	0	2	4	6	8	L	R	C ₀	C ₁	C ₂	
TONE	+6	+5	+4	+3	+2	+1	0	-1	-2	-3	-4	-5	-6	L	R	C ₀	C ₁	C ₂

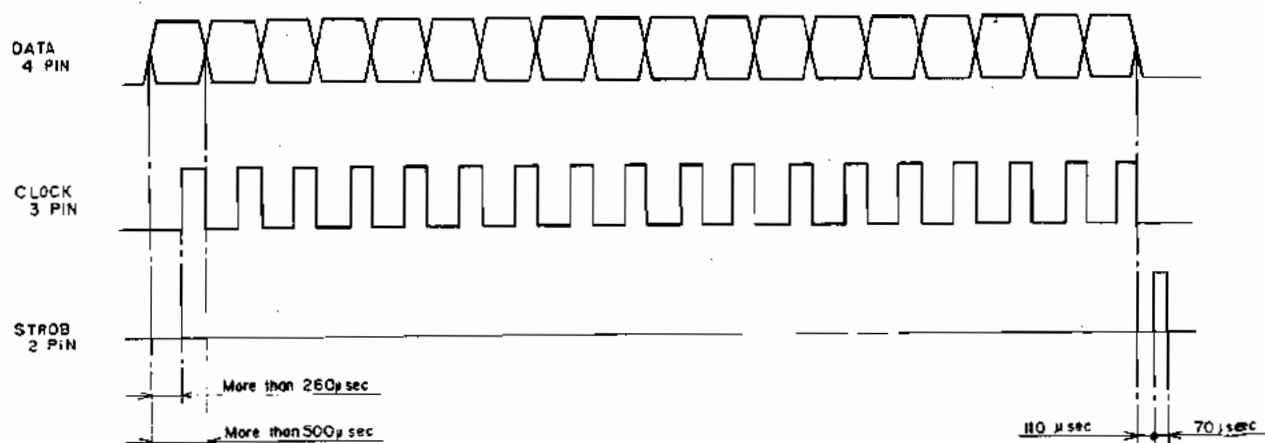

Fig. 1-12 Serial Transfer Data

The leading edge of the clock pulse occurs more than 260 μsec after the data bit is set, and at this point, reception of the data takes place. At the trailing edge of the clock pulse, the data bit sets the next data. When this is repeated for 18 bits, the clock is turned

OFF and after 110 μsec the pulse of 70 μsec is output, and the IC chip selected by C₀, C₁ or C₂ is set to the value corresponding to the data taken in. In the case of VOLUME, the data of the 13th bit is not used, but 0 is always output.

6-3. COMPOSITION OF VOLUME IC TC9154P AND TONE CONTROL (BASS, TREBLE) IC TC9156P

6-3-1. Internal Block Diagram of TC9154P (Volume)

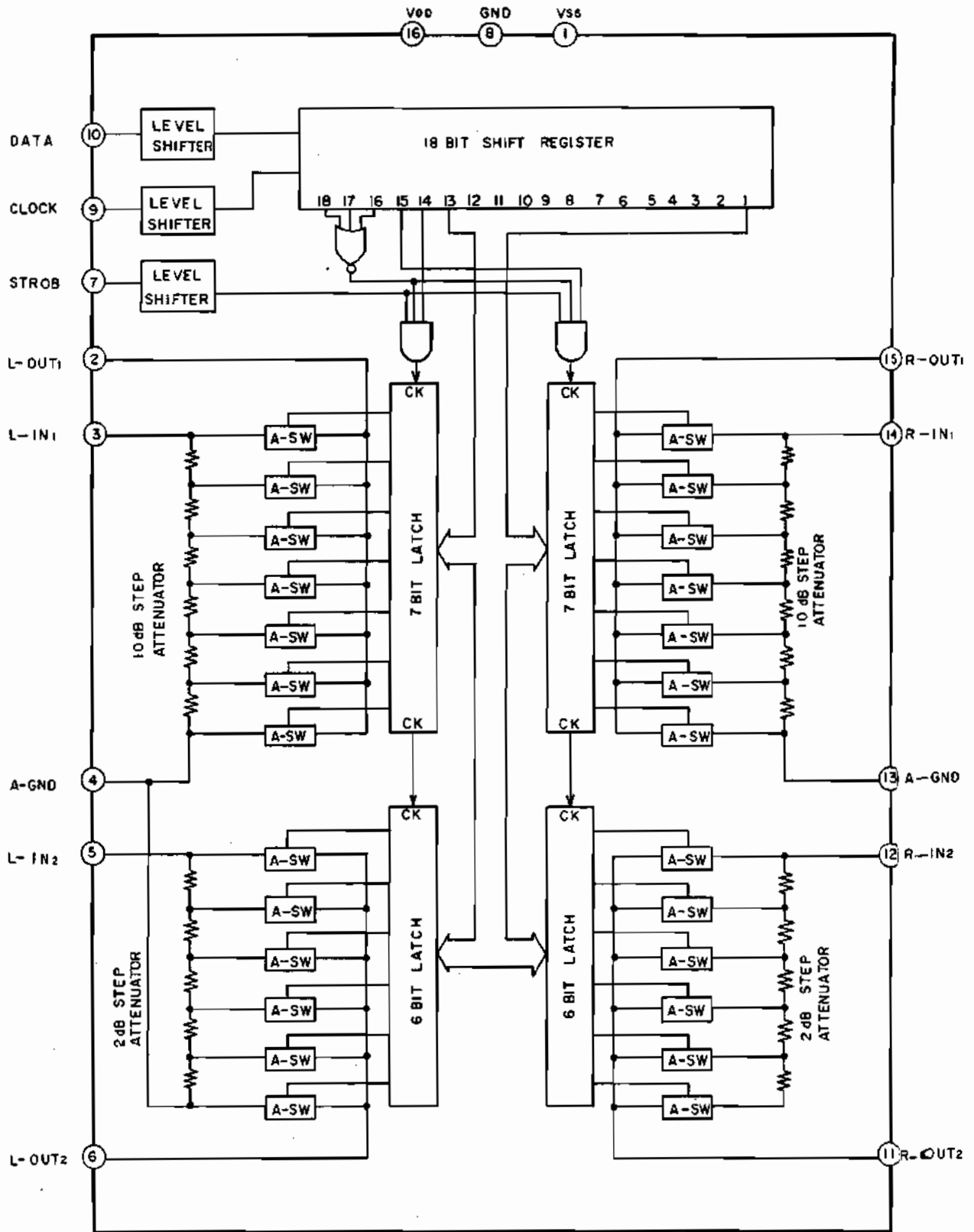

Fig. 1-13 Internal Block Diagram of TC9154P

6-3-2. Attenuator of TC9154P

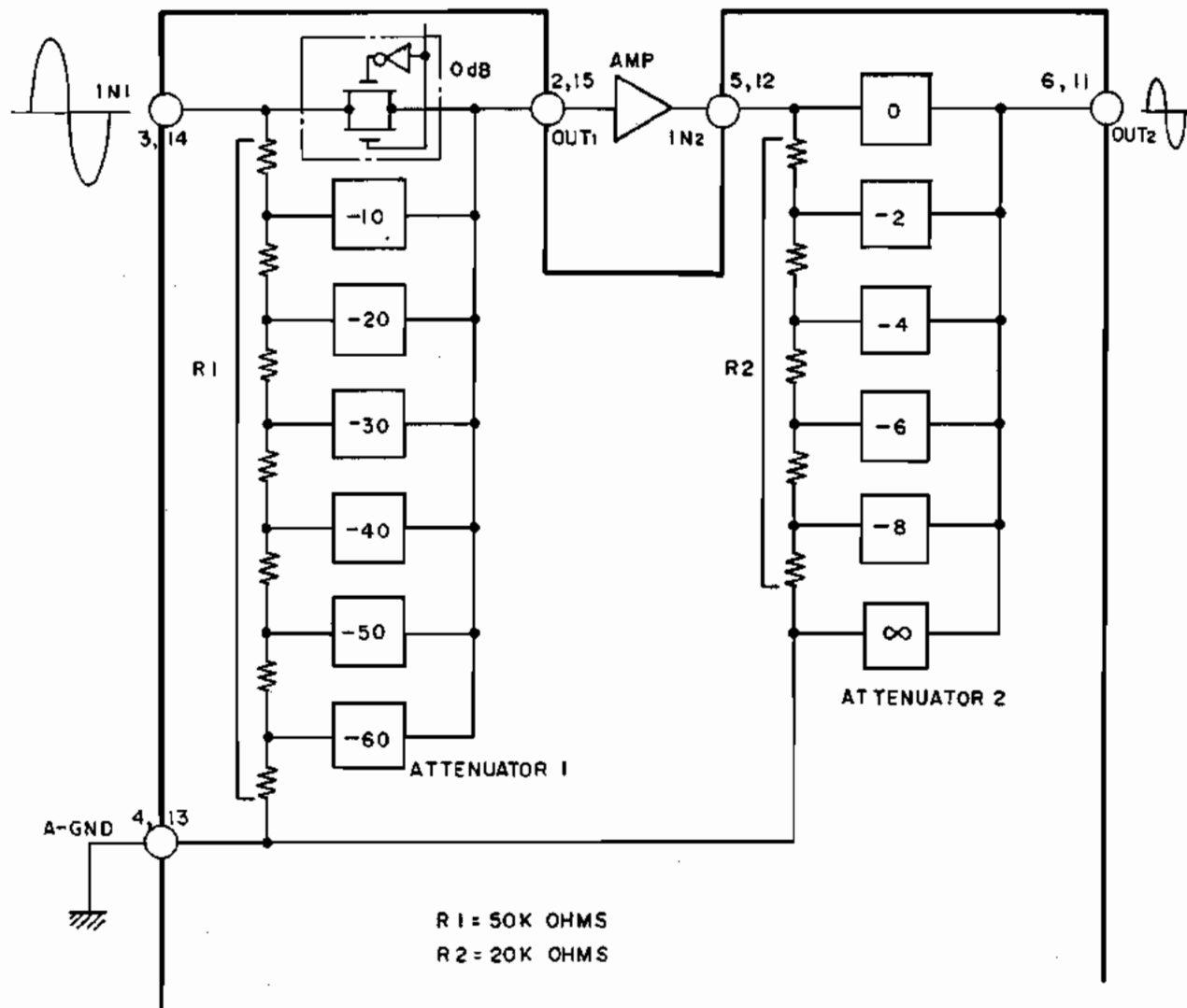

Fig. 1-14 Attenuator of TC9154P

The attenuator consists of diffused resistors and analog switches. Attenuator 1 attenuates 0dB to 60dB in steps of 10dB and Attenuator 2 attenuates 2 to 8dB in steps of 2dB, thus attenuating 0 to 66dB in total in steps of 2dB.

6-3-3. Internal Block Diagram of TC9156P (BASS, TREBLE)

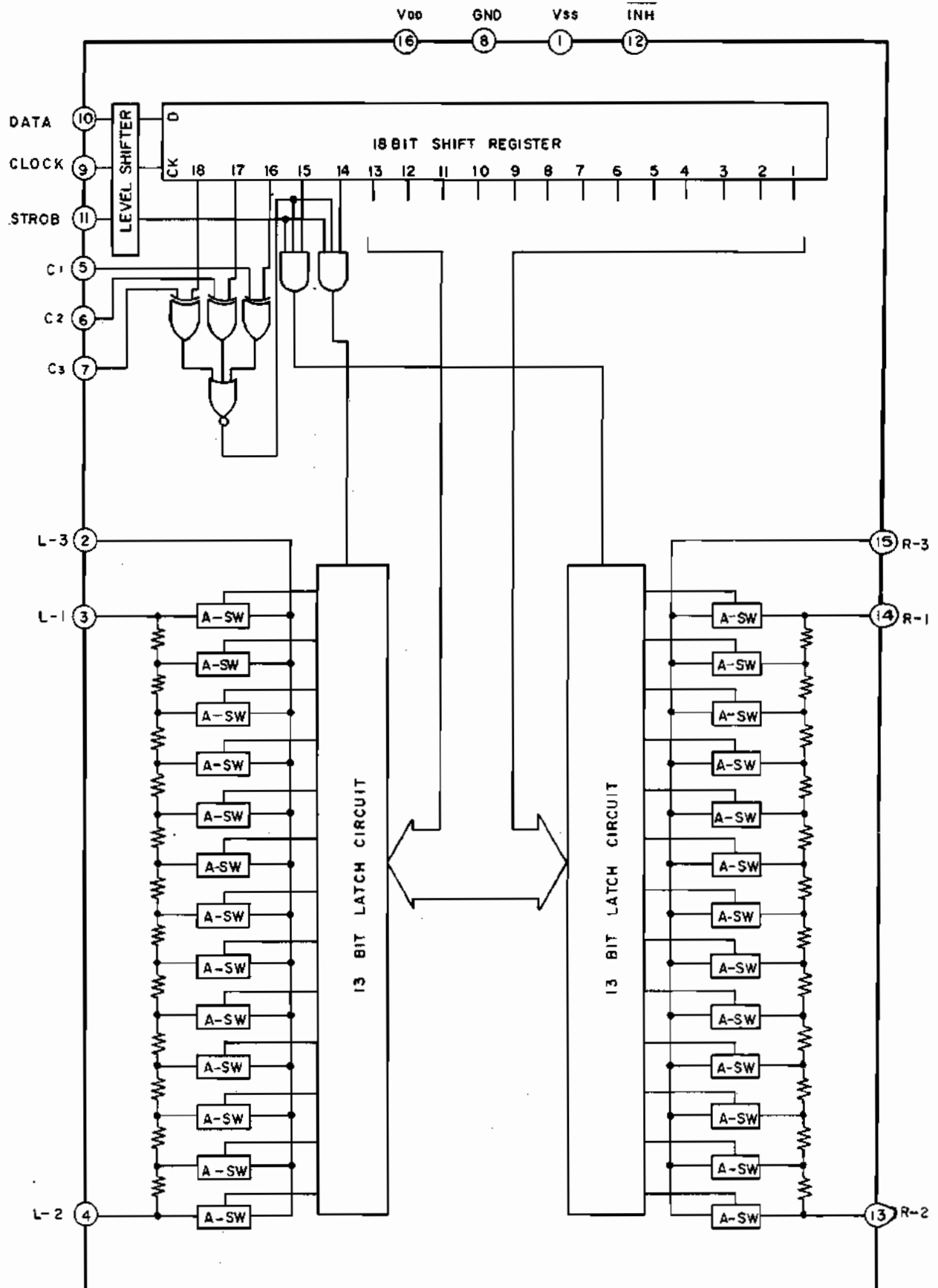

Fig. 1-15 Internal Block Diagram of TC9156P

6-3-4. Variable resistor of TC9156P

The variable resistor consists of diffused resistors and analog switches.

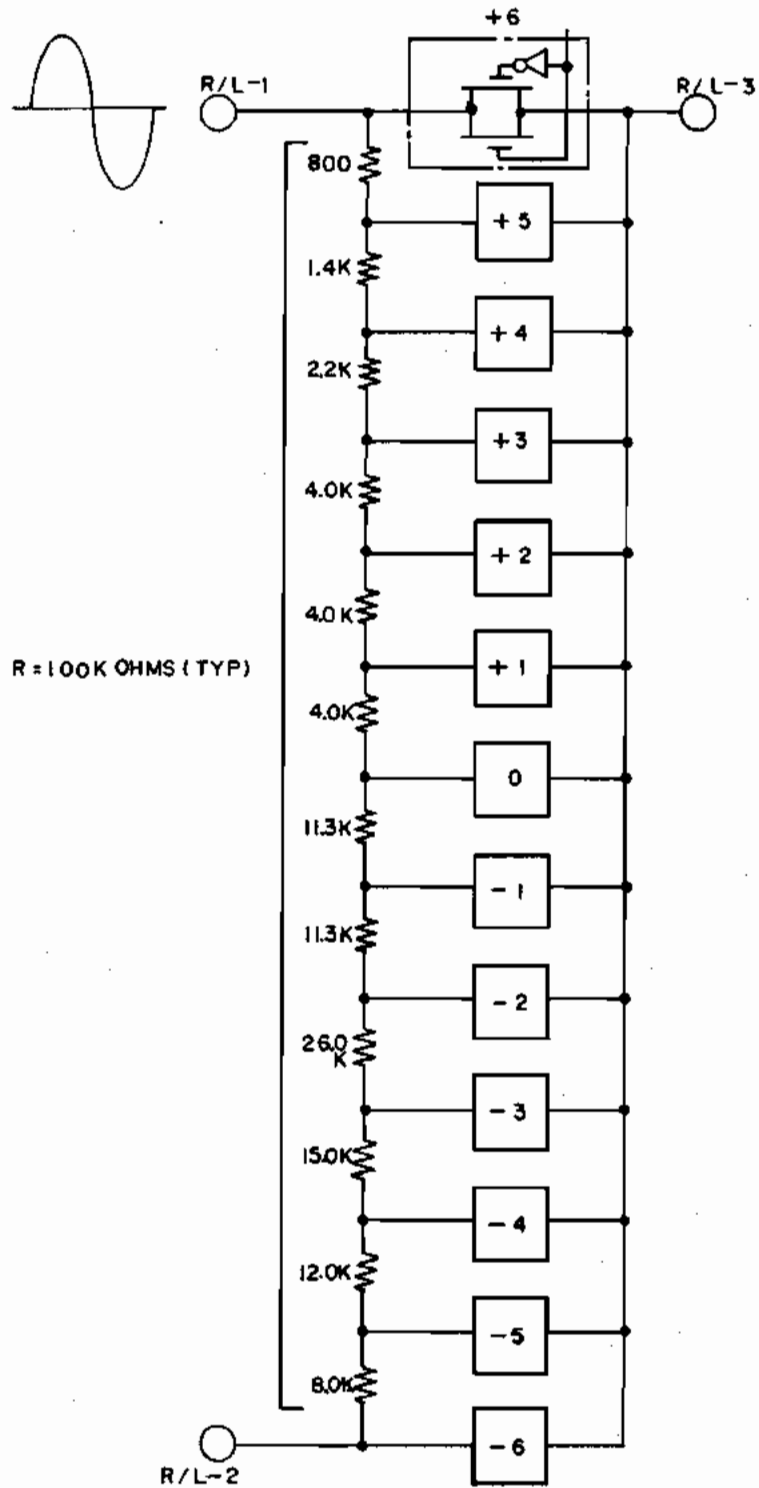

Fig. 1-16 Variable Resistor of TC9156P

6-3-5. Operation

By entering optional attenuation data from the DATA, CLOCK or STROB terminal, the internal attenuator is set. The data stream consists of 18 bits as follows.

1) VOLUME

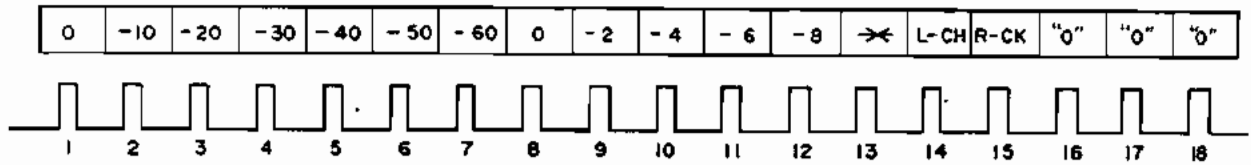

Fig. 1-17 Data of Volume Control

If, for example, the data stream 000100001000011000 is input by the clock from the data terminal, the attenuation will be -32dB.

2) TONE Control

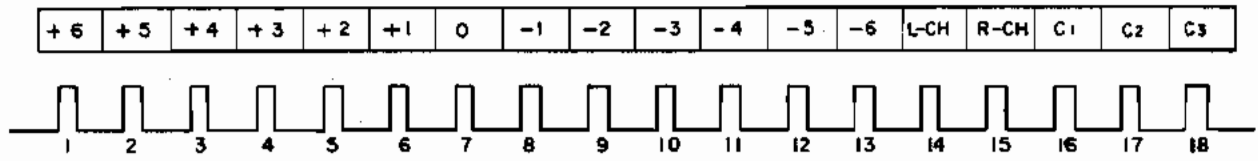

Fig. 1-18 Data of Tone Control

If, for example, the data stream 000100000000011000 is input by the clock from the data terminal, the position will be +3.

3) The data stream taken in is synchronized with the STROB signal to set the attenuator. (same for VOLUME and TONE controls)

Example: Volume IC

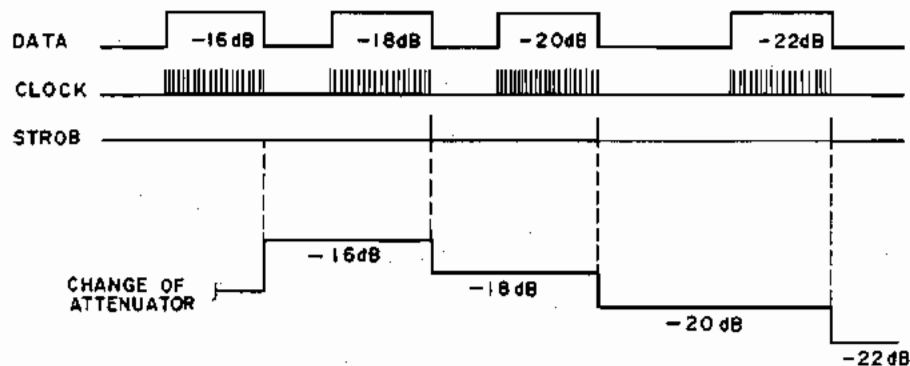

Fig. 1-19 Relation of Data and Attenuator

6-3-6. UP/DOWN Operation of VOLUME Control

The VOLUME varies in steps of 2dB each from 0dB to 66dB and the step ∞ totalling 35 electronic steps. (10 display steps for FL display)

- 1) Step by pressing of VOLUME Control
 - a. The volume moves UP or DOWN one step at a time, thus changing the display accordingly. Pressing VOLUME during the BALANCE display will only switch to the VOLUME display at the existing value without changing it.
 - b. No action will occur at MAX or MIN even if further UP or DOWN action is attempted.
- 2) Continuous pressing (Holding down the key)
 - a. After the first 2dB step, the second 2dB step occurs after 500msec and subsequently changes in 2dB steps occur every 170msec, and the display follows. But if the pressing is started during the BALANCE display, the first display is only switched to VOLUME without changing its value, and then, after 500msec, the volume setting is changed every 170msec.
 - b. The rest is the same as 1).

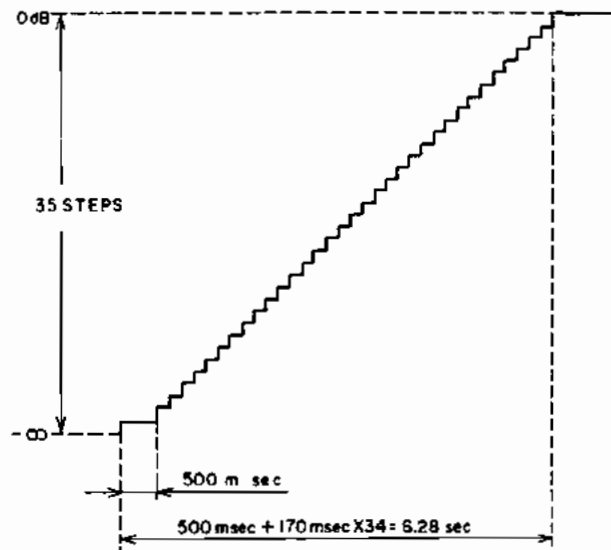

Fig. 1-20 Volume Change
(when the key is continuously pressed)

6-3-7. UP/DOWN Operation of BASS and TREBLE

Both BASS and TREBLE vary in steps of ± 5 from 0, totalling 11 steps.

- 1) Step by step pressing of Tone Controls
 - a. The value is changed one step at a time to the + or - side.
 - b. The display is changed (point display).
 - c. No further action after reaching MAX or MIN.
 - d. All the acoustic memory displays become invisible and the response line is lit.
- 2) Continuous pressing (Holding down the key)
 - a. After the first one step change, the second step change occurs after 500msec, and then, subsequently the value is changed every 170msec. However at the centre value, a 640msec stop occurs before going to the next step. (See Fig. 1-21)
 - b. The rest is the same as 1).

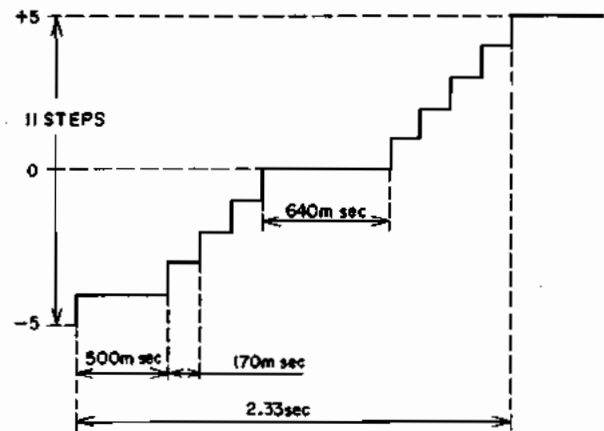

Fig. 1-21 Volume Change of BASS and TREBLE

6-3-8. BALANCE Control

The Balance value varies in ± 10 steps from 0 totalling 21 steps.

- 1) Step by step pressing
 - a. Change will occur one step at a time to LEFT or RIGHT and the display is also changed in sympathy. However operation of BALANCE during the display of VOLUME, results in the change of display to BALANCE without change of setting.
 - b. Once the LEFT or RIGHT end is reached, no further action will occur even if the key is pressed again.
 - c. After the key is pressed for the last time, the display is switched automatically to VOLUME after 5 sec.

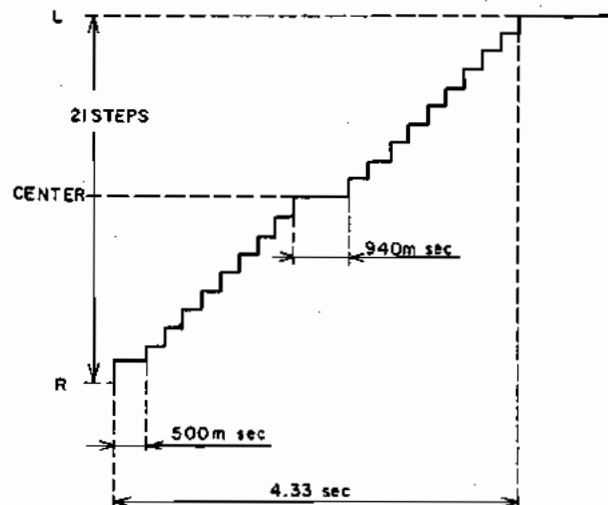

Fig. 1-22 BALANCE Change

- 2) Continuous pressing (Holding down the key)
 - a. After the first step change 500msec elapses and subsequently one step change is made every 170msec and the display changes in sympathy. But if the pressing is started during the VOLUME display, the first display is changed

6-3-9. Operation of FADER

- 1) 1st pressing
 - a. The attenuator is set to ∞ to create MUTE status. But the VOLUME display remains same.
 - b. The single segment of FADER is lit.
- 2) 2nd pressing
 - a. Fading-in occurs at about 60msec/step up to the VOLUME value prior to the MUTE condition.
 - b. FADER segment is lit every 5 steps, and finally extinguished.

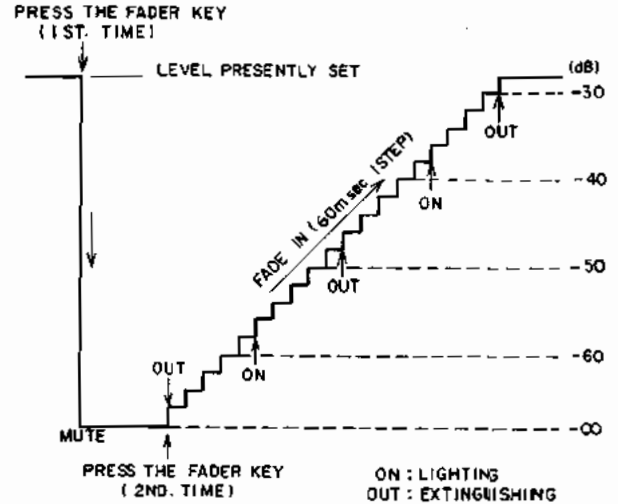

Fig. 1-23 FADE IN

7. THE STATUS THAT WILL BE ESTABLISHED WHEN RESET BUTTON IS PRESSED

Function:	Tuner (FM)
Tape 1:	OFF
Tape 2:	OFF
Bass:	Flat (Defeat)
Treble:	Flat (Defeat)
Volume:	40 dB Point (FLD Volume Indicator = "3")
Balance:	Center
Acoustic Memory:	Cancel
Preset Station:	Cancel

8. RESET STATUS WHEN POWER IS ON

When the power for this micro-computer becomes OFF, the clock ceases to operate and the inner status is maintained by the back-up capacitor. Therefore, the last setting is reset in principle.

Reset status when power is ON

Point	Preset status when power is recovered
Function:	Last selection
Tone:	Value of the last setting. If power is turned OFF while the acoustic memory is being loaded, the acoustic display will not be reset.
Volume:	OFF at less than 26dB → 1st setting OFF at 26dB or more → 26dB (indicator "5")
Balance:	Last setting
Acoustic Memory:	Last setting for the contents stored
Fader:	OFF in MUTE → MUTE released OFF in FADE-IN → FADE-IN terminated
Acoustic Lighting:	Lighting terminated
BALANCE Display:	VOLUME display

If the voltage of the back-up capacitor has fallen below the holding voltage of this micro-computer after the power has been switched OFF for a long time, the last setting cannot be reset when the power is recovered.

9. HOW TO MAKE LETTERS (AA-R32 and R42 only)

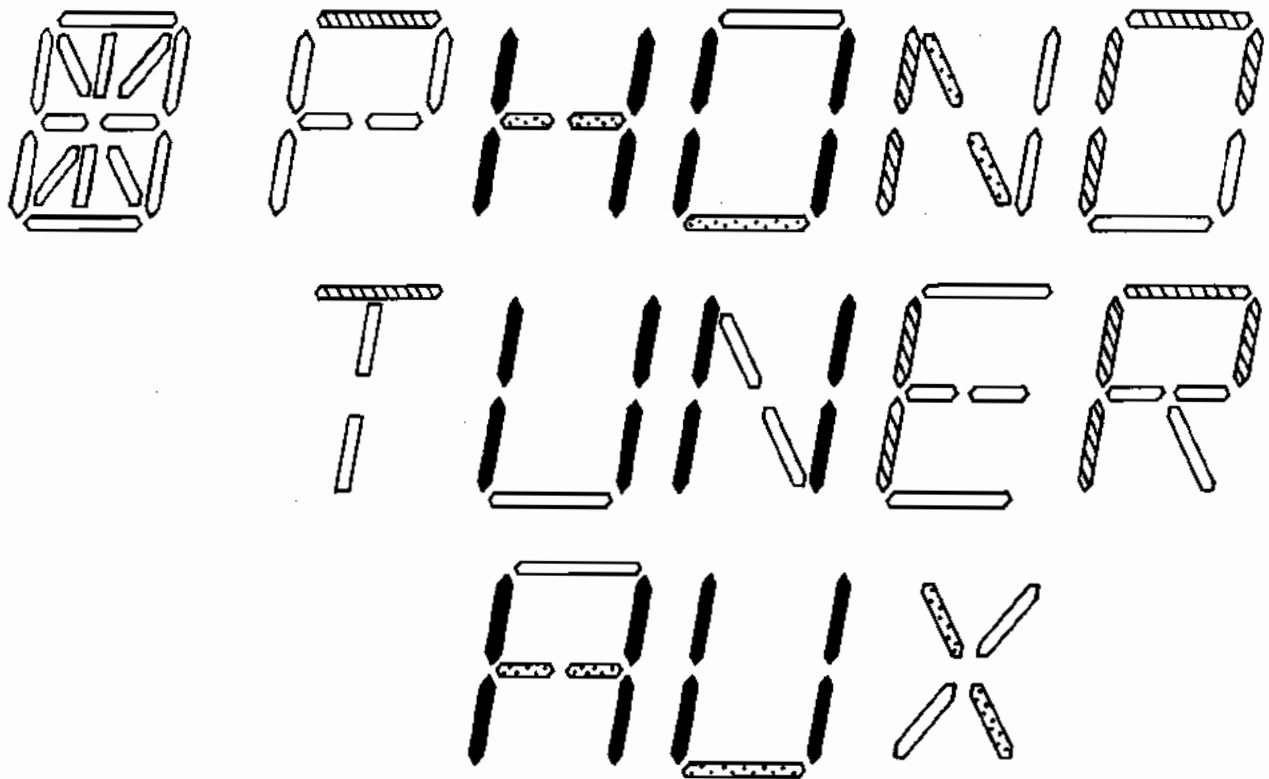

Fig. 1-24

Common parts in the above 3 patterns S6 (FLD PIN 82)



Common parts in PHONO, TUNER S5 (FLD PIN 84) (except S6)



Common parts in PHONO, AUX S4 (FLD PIN 85) (except S6 and S5)



Segment used in TUNER only S3 (FLD PIN 86)

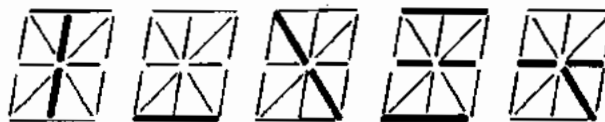

Fig. 1-25

Segment used in AUX only S2 (FLD PIN 88)

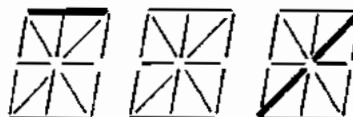

Fig. 1-26

Segment used in PHONO only S1 (PIN 89)



Fig. 1-27

That is, in order to display the letter of PHONO, AUX or TUNER, the data may be output so that S6, S5, S4 and S1; S6, S4 and S2, or S6, S5 and S3 are lit respectively.

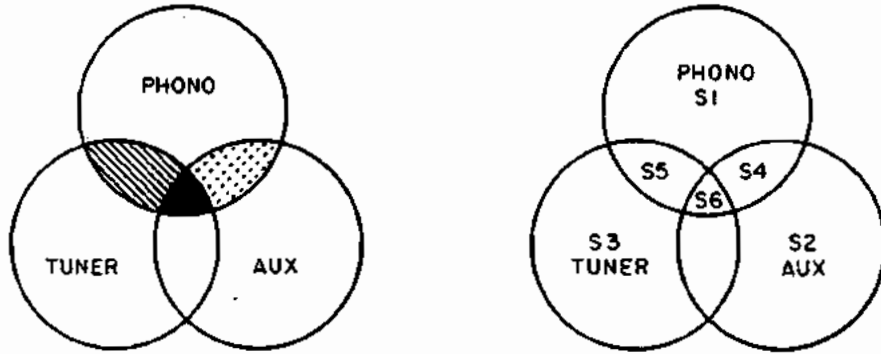

Fig. 1-28

Since the data from the micro-computer includes only one data each to become "H" in AUX, TUNER AND PHONO, it is resolved as follows.

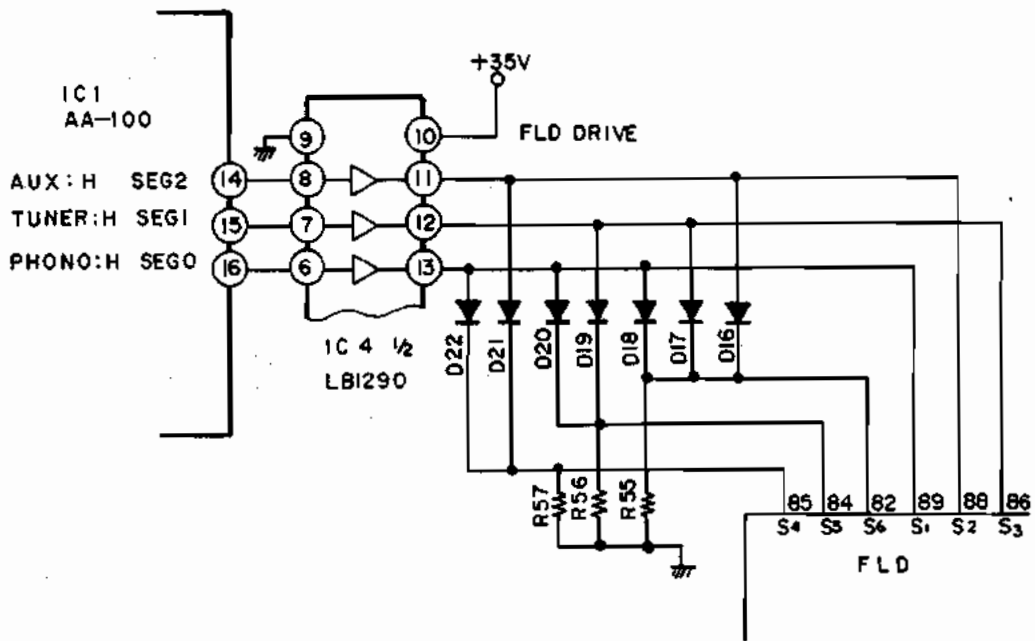

Fig. 1-29 Resolve Circuit of Data

III. OPERATION OF TUNER SECTION CONTROL IC AT-600 PERIPHERAL CIRCUIT

1. BLOCK DIAGRAM OF AT-600 PERIPHERAL

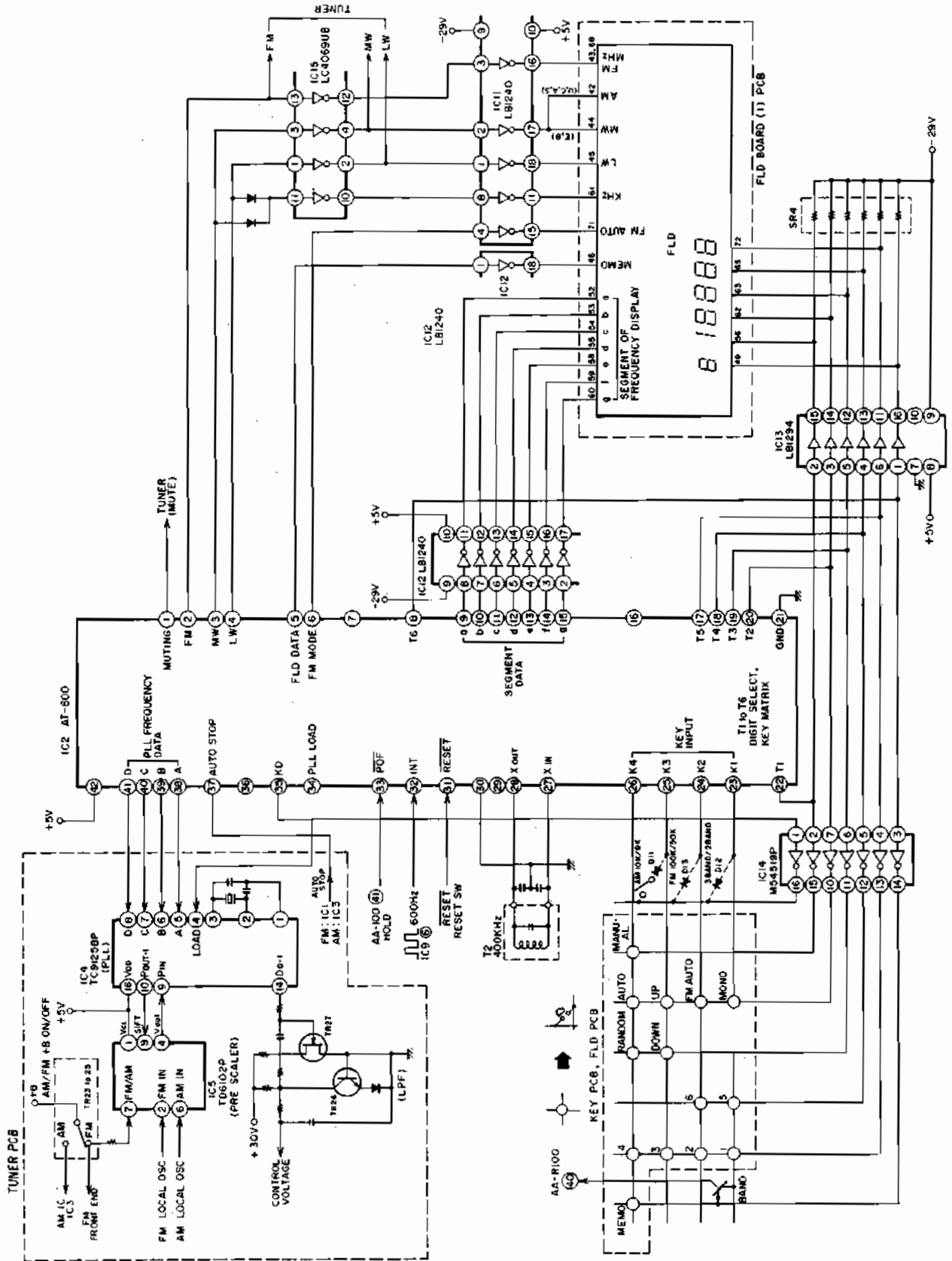

Fig. 1-30 Block Diagram of AT-600 Peripheral (AA-R21/L)

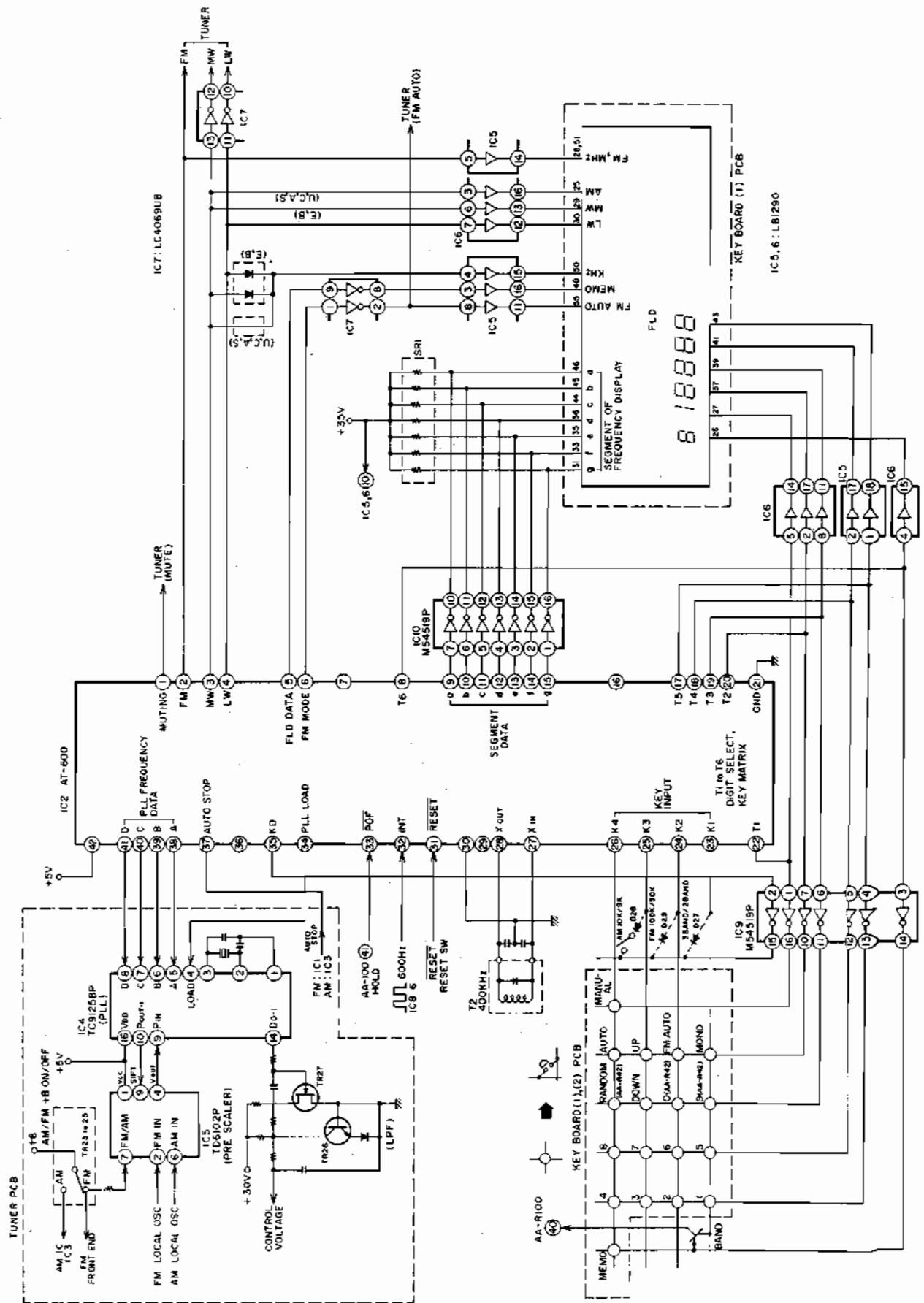
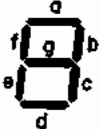

Fig. 1-31 Block Diagram of AT-600 Peripheral (AA-R2/L, 42)

2. AT600 TERMINALS DESCRIPTION

No.	Terminal Description	Function
1	Muting	H = Muting OFF L = Muting ON
2	FM	H = FM L = MW (AM) or LW
3	MW	H = MW (AM) L = FM or LW
4	LW	H = LW L = FM or MW
5	FLD DATA	Light up the FLD of MANUAL SCAN, AUTO SCAN, MEMO
6	K1 SIGNAL (FM MODE)	H = FM MONO L = FM AUTO
7	K2 SIGNAL	unused
9	a	 <p>Frequency Display, Preset Channel Segment Data</p>
10	b	
11	c	
12	d	
13	e	
14	f	
15	g	
16		
8	T6	TIMING CONTROL
17	T5	
18	T4	
19	T3	
20	T2	
22	T1	Display Digit Select
21	GND	Key Matrix
23	K1	KEY Input
24	K2	
25	K3	
26	K4	
27	XIN	Connect a OSC Coil
28	XOUT	
29	CK	CAL TONE Signal
30	TEST	
31	RESET	ACTIVE LOW → Reset
32	INT	Interrupt Signal
33	POF	Power OFF manage.
34	PLL LOAD	PLL Load Signal
35	KD	Lock SW input.
36	NC	
37	AUTO STOP	L = AUTO STOP
38	A	PLL Frequency Data
39	B	
40	C	
41	D	
42	VDD	Power terminal +5V

3. KEY MATRIX AND TIMING CHART OF SIGNAL FOR DISPLAY SELECTION BLANK PERIOD

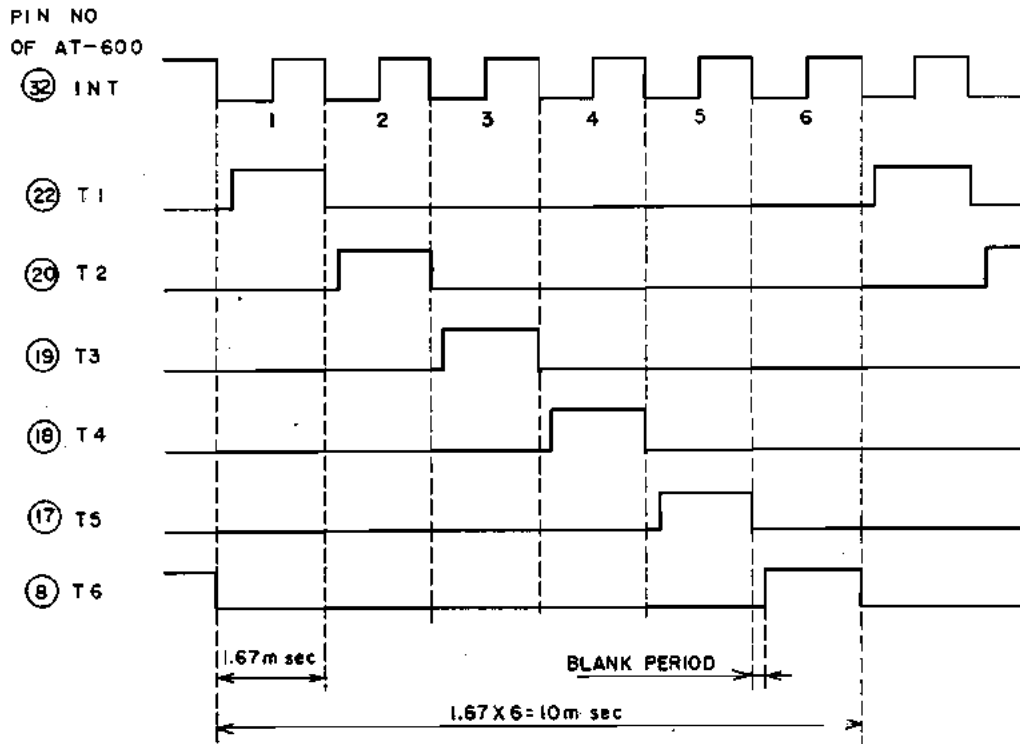

Fig. 1-32

4. FREQUENCY DISPLAY SEGMENT DATA (WHEN FREQUENCY IS 98.00 MHz)

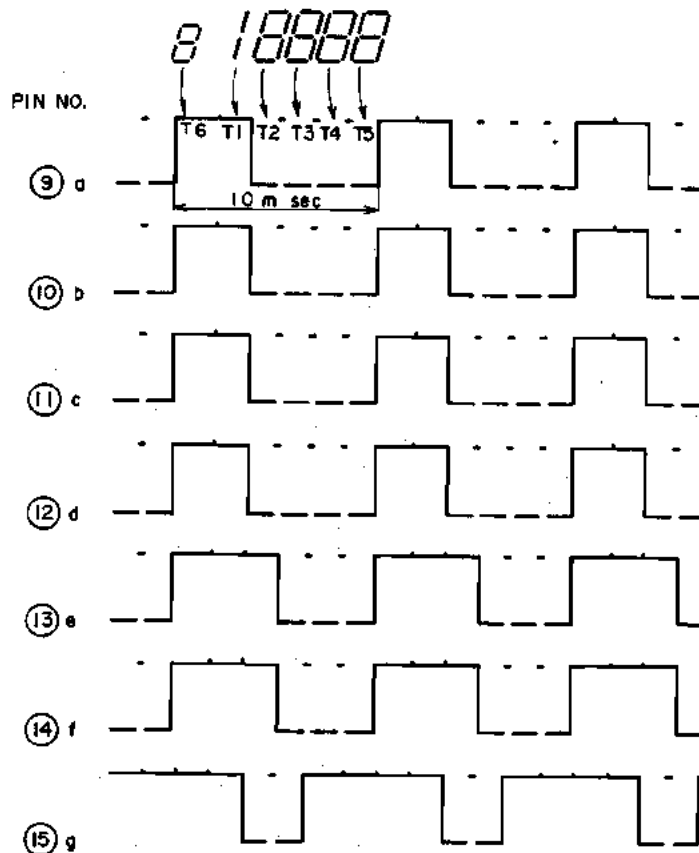

Fig. 1-33

5. BLOCK DIAGRAM OF PLL IC TC9125P INTERIOR AND DESCRIPTION OF THE FUNCTION OF EACH TERMINAL

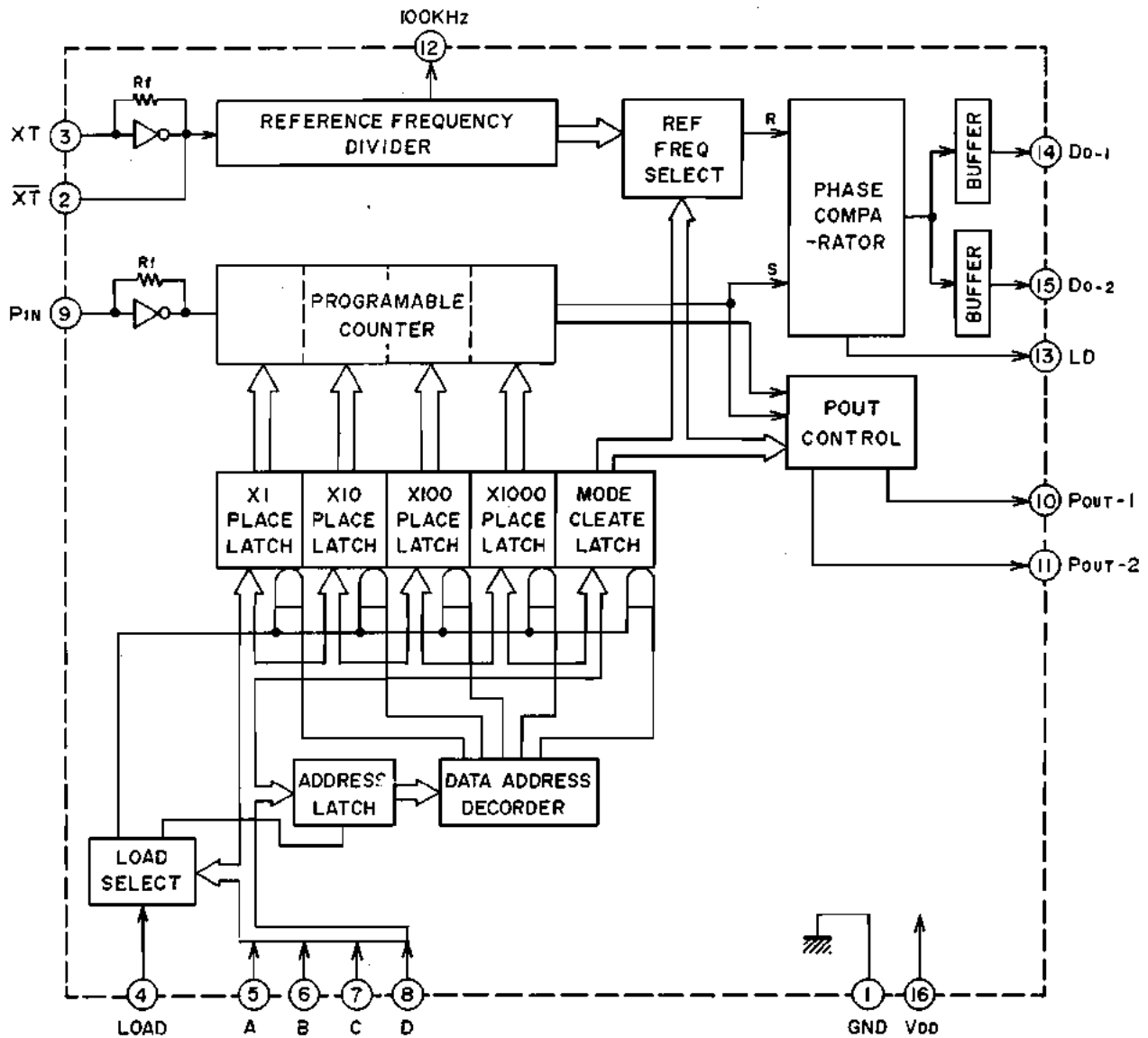

Fig. I-34

Pin No.	Symbol	Designation of terminal	Description of functions and operations
1	GND	Earth terminal	
2 3	\overline{XT} XT	Crystal oscillator connection terminal	Connection of 9.0MHz crystal oscillator.
4	LOAD	Load input terminal	Data reading instruction input terminal for A, B, C and D. Data is read when this terminal is at "H" level, but when at "L" level, the previous data is held regardless of other inputs.
5 6 7 8	A B C D	Program/data input terminals	Input terminal for reference frequency selection data and programmable counter division digit data.
9	PIN	Programmable counter input terminal	
10 11	POUT-1 POUT-2	Programmable counter output terminal	To be connected to the prescaler TD6102P for fine adjustment of IF frequency in FM or for 50 kHz shift in Europe. The signal of Pout-1 and Pout-2 is output at the point of different phase.
12	100 kHz	100 kHz clock output terminal	
13	LD	Lock-out detection terminal	"H" level when lock-out occurs.
14 15	Do-1 Do-2	Phase comparator output terminal	To be connected to low-pass filter.
16	VDD	Power terminal	+7V

Fig. 1-35

6. PLL DATA FOR PLL IC (TC9125P) CONTROL

The data received from ⑭ to ⑰ of Micro-computer (IC2 AT-600) includes the mode data to select the reference frequency and to control the P out output, and the PLL data to determine the dividing factor of the programmable counter. This PLL data is added to the A to D terminals (⑤ to ⑧) of TC9125P. The data reading is controlled by the load terminal (④), i.e. when the load terminal is at "H", the data from A to D is read into the latch, and when "L", no reading is done but the previous data is retained. The PLL data is determined in the following manner.

FM:

$$\text{PLL data} = [\text{received frequency} + \text{IF frequency}] \times 10$$

Example: 98MHz received.

$$\text{PLL data} = [98.0 + 10.7] \times 10 = 1087$$

MW (AM):

$$\text{PLL data} = \frac{\text{Received frequency} + \text{IF frequency}}{\text{frequency change of 1 step}}$$

Example: 530 kHz received (10 kHz steps)

$$\text{PLL data} = \frac{530 + 460}{10} = 99$$

LW:

$$\text{PLL data} = \text{received frequency} + \text{IF frequency}$$

Example: 137 kHz received

$$\text{PLL data} = 137 + 459 = 596$$

PLL data values for received frequencies are as follows.

Band	Received frequency	Tuning 1 step	PLL data	IF frequency
FM	87.4 ~ 108.1 MHz	50/100 kHz	981 ~ 1188	10.7 MHz
MW ₁	530 ~ 1610 kHz	10 kHz	99 ~ 208	460 kHz
MW ₂	522 ~ 1611 kHz	9 kHz	109 ~ 230	459 kHz
LW	137 ~ 362 kHz	1/9 kHz	596 ~ 821	459 kHz

Fig. 1-36 PLL Data

MODE data values are as follows.

Band	Tuning 1 step	Mode data
FM	100 kHz	4
FM	50 kHz	5
MW ₁	10 kHz	3
MW ₂	9 kHz	2
LW	1 kHz	0

Fig. 1-37 Mode Data

The PLL data and MODE data are received in the following way and added to A to D or TC9125P.

Example: FM 108 MHz (100kHz steps) received:

$$\text{PLL data} = (108 + 10.7) \times 10 = 1187$$

$$\text{MODE data} = 4$$

The each figure of PLL data is converted into binary code of 4 bits (A = LSB, D = MSB).

The MODE data is converted into binary code of 3 bits (A = LSB, C = MSB, D = 0).

In order to determine to which latch in TC9125 the above data should be set, the data that designates the address is input first.

The address is determined in the following manner.

Latch	×1 Place	×10 Place	×100 Place	×1000 Place	Mode cleate
Address	F = 11	F = 12	F = 13	F = 14	F = 15

$$F = 1 \cdot A + 2 \cdot B + 4 \cdot C + 8 \cdot D \quad (A, B, C, D = 1 \text{ or } 0)$$

Fig. 1-38 Address Data

If F = 11 is set, $F = 1 \times 1 + 2 \times 1 + 4 \times 0 + 8 \times 1 = 11$, and A, B, C and D will be 1, 1, 0, and 1 respectively. Each

PLL data value is sent together with the data designating the address and set to the latch.

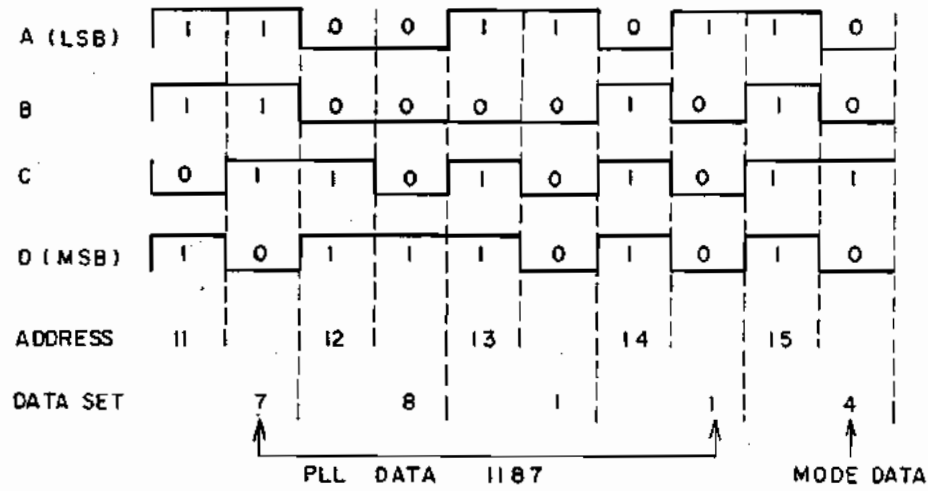

Fig. 1-39 PLL Data Transfer

7. FREQUENCY CONTROL BY PLL

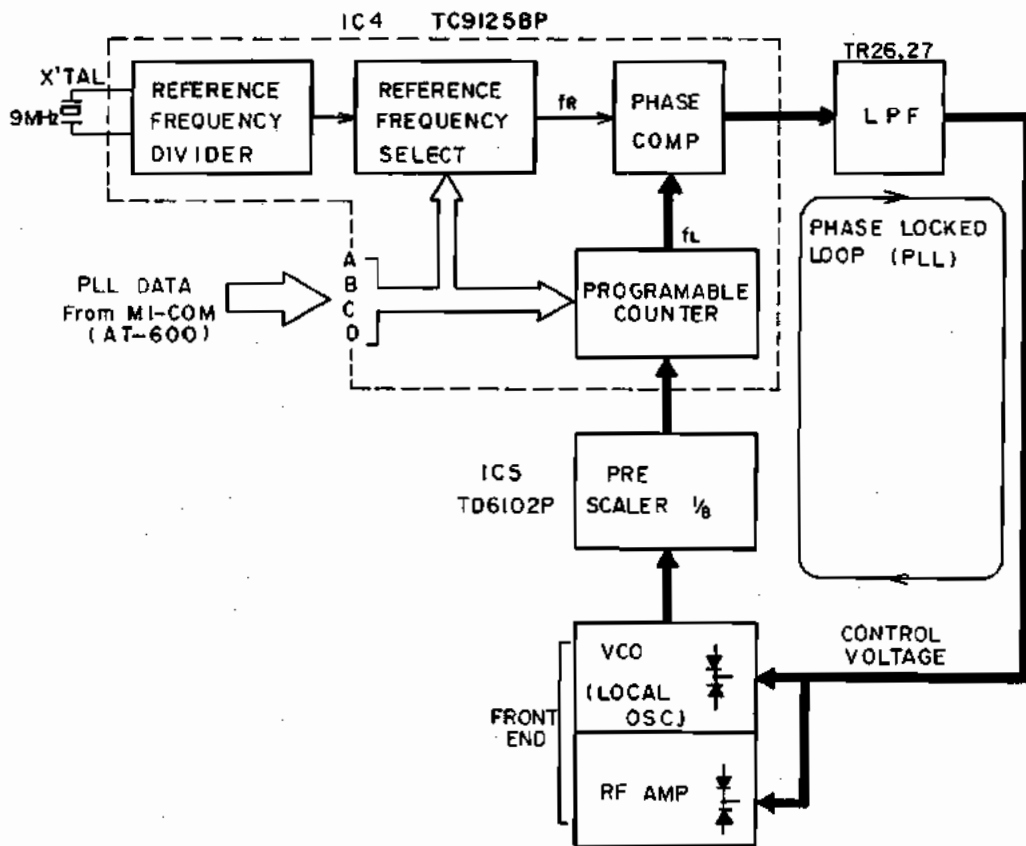

Fig. 1-40 Control of received frequency

The signal from the reference frequency divider and the signal from the VCO (local osc.) are divided by the dividing factor determined by the PLL data, to become f_R and f_L respectively. The phase comparator compares the frequency and phase of the frequencies f_R and f_L . If f_L is delayed in phase relative to f_R ,

"L" is output and if f_L is advanced relative to f_R , "H" is output. The output passes through the LPF (low pass filter) and by changing the inverse voltage of the varactor diodes in VCO (local OSC.) and RF amplifier, the tuning frequency is controlled.

IV. AKAI ZERO DRIVE CIRCUIT (AA-R42/R32)

1. IN THE BEGINNING:

Many techniques concerned with negative feedback (NF) such as NON NFB, low feedback amplifier, super FF, linear feedback and pure NF have been much talked about in the world of audio. All these techniques were developed to compensate for the drawbacks and imperfections of NF. At the present, NF has the following problems:

- 1) Theoretically, zero distortion is impossible.
- 2) Phase compensation is necessary for high frequency stability.
- 3) Due to above, NF value is reduced at high frequencies and thus distortion rate at high frequencies is increased. Such distortions as switching and cross-over distortions cannot be completely eliminated.
- 4) Back electromotive force from the speakers is fed back to the input side through the NF circuit, thus producing Interface Intermodulation (IIM) distortion.
- 5) There is a danger of adversely affecting the dynamic characteristics.

Consequently, it is impossible to talk about today's audio amplifiers without thinking in terms of NF, as it cannot be completely ignored. NF is an innovative technique and Akai believes that more efforts should be applied and a more technical approach is needed to eliminate its drawbacks and to take advantage of its merits. With this in mind, Akai decided on the following conditions when designing the new circuit.

- 1) Effective distortion correction without increasing feedback value.
- 2) Be effective and stable at high frequencies, so it must be based on the principle of error correction and not NF technique.
- 3) Nothing must be added or taken away from the original signal components.
- 4) Supplementary to conventional circuits without extensive changes.
- 5) Complete suppression of IIM distortion.

2. PRINCIPLE OF AKAI ZERO DRIVE CIRCUIT

2-1. NF OPERATION OF A CONVENTIONAL AMPLIFIER

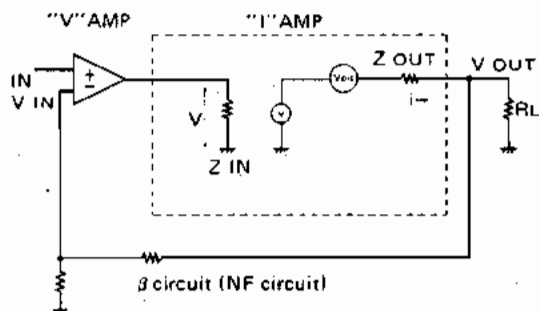

Fig. 1-41

For convenience, the main amplifier was divided into two sections: the "V" AMP section for amplifying voltage, and the "I" AMP section for amplifying current. For explanation, circuit equivalent to the "I" AMP is shown in Fig. 1-41. Thanks to the improvements in the characteristics of component parts and to circuit technology, it is now possible to design a "V" AMP having quite good characteristics. However, still to be overcome is the problem of nonlinear distortion of component parts due to switching and crossover distortions and the circuit's wide operating range.

Despite much effort to resolve all these problems by improving the characteristics of component parts and creation of new circuit technology (such as non-switching), the ultimate goal still remained unattained. Beside this, the problem has been raised of such distortion as IIM distortion which results when a part of the speaker's back electromotive force is mixed with the input signal through the β circuit (NF circuit). There are still many problems with "I" AMP.

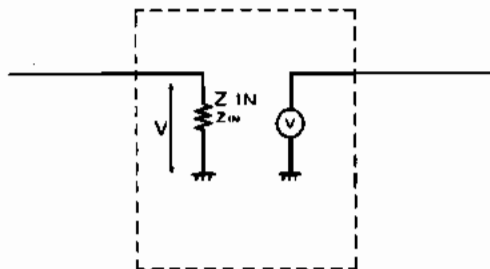

Fig. 1-42

An ideal "I" AMP without these problems is shown in Fig. 1-42. It successfully accomplishes zero output impedance and zero distortion.

1) How the circuit in Fig. 1-41 operates

The "I" AMP produces on the output side a voltage equivalent to the voltage V supplied by the "V" AMP to the input side. At the same time, V_{OUT} due to the voltage of distortion component (V_{DIS}) and the reduced voltage of output impedance (Z_{OUT}) is equated as:

$$V_{OUT} = V - (V_{DIS} + Z_{OUT} i) \dots \dots \dots (1)$$

where:

V is the component equal to the input signal, and $(V_{DIS} + Z_{OUT} i)$ is the voltage due to distortion and output impedance or otherwise called composite distortion.

Since this is in fact an NF circuit, component which cancel this composite distortion is fed back to the input side, thus reducing distortion rate.

When:

- A = amplifier open loop gain
- β = gain of the amplifier
- NF = value of the negative feedback

$$NF = A/\beta \dots \dots \dots (2)$$

V is then expressed as:

$$V = \beta V_{in} + \frac{NF}{NF + 1} (V_{DIS} + Z_{OUT} i) \dots \dots (3)$$

From (1) and (3), final output is given as:

$$V_{OUT} = \beta V_{in} + \frac{1}{NF + 1} (V_{DIS} + Z_{OUT} i) \dots (4)$$

From (4), the input signal is magnified β times for a conventional amplifier and distortion and output impedance becomes $1/(NF + 1)$.

2-2. ABSORPTION OF SPEAKERS BACK ELECTROMOTIVE FORCE IN A CONVENTIONAL AMPLIFIER

(For simplification, V_{DIS} was omitted.)

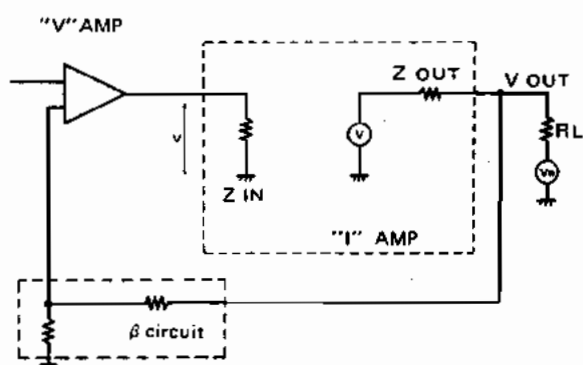

Fig. 1-43

Fig. 1-43 shows a circuit equivalent to a speaker which produces back electromotive force with R_L and back electromotive force V_R in a series circuit. At this time, the amplifier produces inverted phase voltage through the NF circuit to absorb the V_R but not completely. The residual voltage is:

$$V_{OUT} = \frac{V_R Z_{OUT}}{R + \frac{NF}{NF + 1} Z_{OUT}} \cdot \frac{1}{NF + 1}$$

$$\left(= -\frac{V_R Z_{OUT}}{R + Z_{OUT}} \cdot \frac{1}{NF} \right) \dots \dots (5)$$

This voltage is fed back to the previous amp stage through the β circuit, magnified " $-NF$ " times,

$$V' = -\frac{V_R Z_{OUT}}{R + \frac{NF}{NF + 1} Z_{OUT}} \cdot \frac{NF}{NF + 1}$$

$$\left(= -\frac{V_R Z_{OUT}}{R + Z_{OUT}} \right) \dots \dots (6)$$

and input to the "I" AMP.

The point that should be noted here is that, as can be seen in (5), complete absorption cannot be obtained. The residual voltage mixes with the input signal through the β circuit, resulting in IIM distortion. Thus the drawback of conventional amplifiers can be readily seen.

2-3. OPERATION OF AKAI ZERO DRIVE CIRCUIT

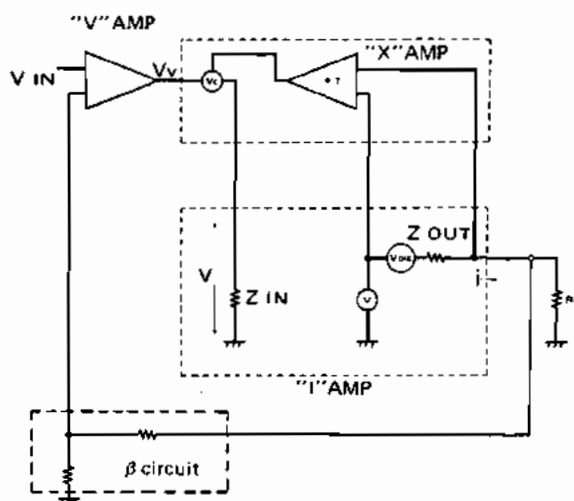

Fig. 1-44

As shown in Fig. 1-44, Akai's zero drive circuit detects the composite distortion of V_{DIS} and $Z_{OUT} i$ by means of a differential amplifier "X" with a gain of 1 and by the principle of error correction, following is added between "I" AMP and the "V" AMP.

$$V_C = V_{DIS} + Z_{OUT} i \dots \dots (7)$$

Writing (3) once more:

$$V_{OUT} = V - (V_{DIS} + Z_{OUT} i) \dots \dots (3)$$

where V is:

$$V = V_V + V_C$$

$$= V_V + (V_{DIS} + Z_{OUT} i) \dots \dots (8)$$

From (3) and (8):

$$V_{OUT} = V_V \dots \dots (9)$$

Therefore:

$$V_V = \beta V_{in} \dots \dots (10)$$

$$V_{OUT} = \beta V_{in} \dots \dots (11)$$

Thus, as seen in (11), adding a zero drive circuit produces an ideal amplifier with zero distortion and zero output impedance. Although, in actual fact, zero cannot be achieved due to the degree of precision of the parts used in the error correction circuit. However, level of $1/100$ ($= -40$ dB) can be easily attained. As Akai's zero drive circuit completely compensates for the drawbacks of general amplifiers, distortions such as switching and crossover distortion are eliminated for all practical purposes. Also, as zero output impedance is achieved, back electromotive force is prevented completely from interfering with the negative feedback circuit and thus IIM distortion is prevented. As for IIM, it operates in the same manner as the non-feedback amplifier.

Present NF Problems	Zero Drive Circuit Advantages
1. Zero distortion impossible.	1. Distortion correction effect without amplifying feedback value.
2. NF value decreases due to prevention of oscillation and circuit for phase compensation. Thus such distortions as switching and cross-over distortions can not be completely removed.	2. As it is based on the principle of error correction which is different from NF, it is stable and effective at high frequencies.
3. Back electromotive force from the speakers returns to the input side through the NF producing IIM distortion.	3. Suppresses completely the IIM distortion because as the output impedance is zero there is no interference with the NF circuit by the speaker's back electromotive force.
4. Danger of adversely affecting the dynamic characteristics.	4. Dynamic characteristics are not adversely affected.

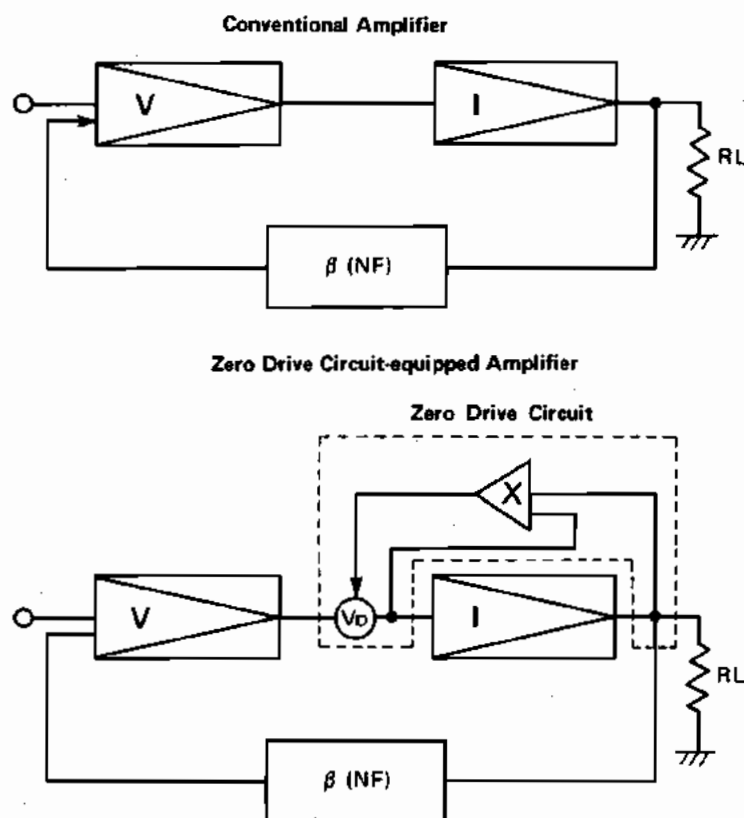

Fig. 1-45

	Output Impedance	Distortion Factor
Conventional "I" Amp	Z	D
Conventional "I" Amp+NF	$Z/1+\beta$	$D/1+\beta$
Ideal "I" Amp	0	0
"I" Amp equipped with Zero Drive Circuit	0	0

V. DUAL-POLE DC SERVO (AA-R42/R32/R22)

A Dual-Pole DC Servo circuit has been employed which further improves the characteristics of the DC amplifier. The Dual-Pole DC Servo, by making the structural components of the integrated circuit in the servo loop Dual-Pole type, namely, dual integrated construction, greatly reduces distortion approximately 40 dB (1/100) and since a servo which has a high purity DC component is applied, the amplification stability of the amplifier is increased and music signals can be more distinctly realized.

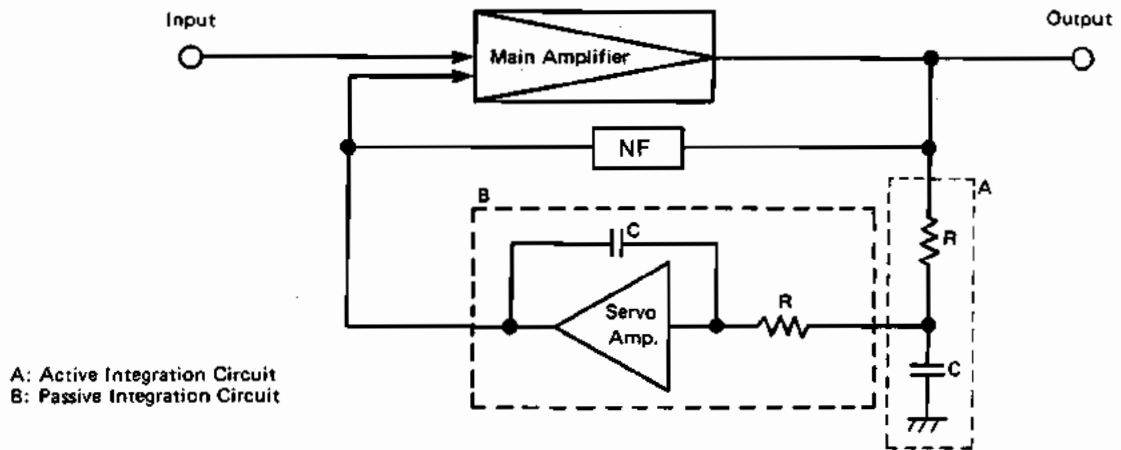
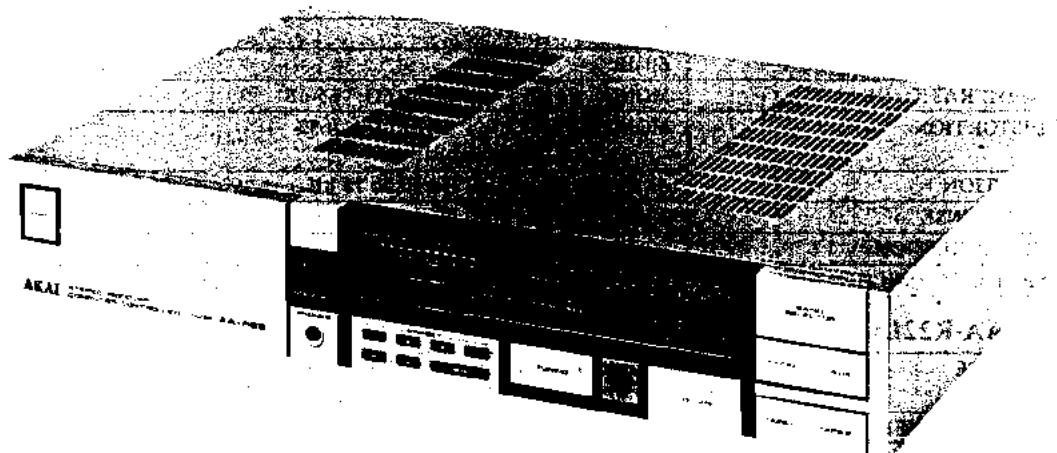

Fig. 1-46



SECTION 2

SERVICE MANUAL

MODEL AA-R22/L

TABLE OF CONTENTS

I.	SPECIFICATIONS	34
II.	DISMANTLING OF UNIT	35
III.	CONTROLS	36
IV.	PRINCIPAL PARTS LOCATION	37
V.	CONVERSION	38
	1. VOLTAGE CONVERSION	38
	2. FM DE-EMPHASIS SELECTOR	38
	3. AM STEP SELECTOR	38
VI.	ADJUSTMENTS	39
	1. CLOCK FREQUENCY ADJUSTMENT	39
	2. TUNER ADJUSTMENT	40
VII.	CLASSIFICATION OF VARIOUS P.C BOARDS	42
	1. P.C BOARD TITLES AND IDENTIFICATION NUMBERS	42
	2. COMPOSITION OF VARIOUS P.C BOARDS	43

For basic adjustments, measuring methods, and operating principles, refer to GENERAL TECHNICAL MANUAL.

I. SPECIFICATIONS

FM TUNER SECTION

FREQUENCY RANGE	87.4 MHz to 108.1 MHz
USABLE SENSITIVITY (30 dB) (IHF)	11.2 dBf
50 dB QUIETING SENSITIVITY (IHF)	16.2 dBf (MONO) 37.2 dBf (STEREO)
CAPTURE RATIO	1.5 dB
SELECTIVITY (IHF)	60 dB
IMAGE REJECTION	85 dB
IF REJECTION	90 dB
SPURIOUS REJECTION	90 dB
AM SUPPRESSION	60 dB
SIGNAL TO NOISE RATIO (IHF)	MONO: 75 dB STEREO: 65 dB
HARMONIC DISTORTION	MONO: 0.1% STEREO: 0.3% (at 100% modulation)
STEREO SEPARATION	45 dB (1 kHz), 35 dB (30 Hz to 15 kHz)
FREQUENCY RESPONSE	30 Hz to 12 kHz \pm 0.5 dB
SUB CARRIER SUPPRESSION	60 dB
ANTENNA INPUT IMPEDANCE	300 ohms balanced, 75 ohms unbalanced

AM (MW for AA-R22L) TUNER SECTION

FREQUENCY RANGE	530 kHz to 1610 kHz (for 10 kHz steps) 522 kHz to 1611 kHz (for 9 kHz steps)
USABLE SENSITIVITY (IHF)	300 μ V/m
SELECTIVITY (IHF)	30 dB
IMAGE REJECTION	40 dB
IFF REJECTION	55 dB
SIGNAL TO NOISE RATIO	40 dB
ANTENNA	Built in Loop Antenna

LW TUNER SECTION (AA-R22L only)

FREQUENCY RANGE	137 kHz to 362 kHz
USABLE SENSITIVITY (IHF)	800 μ V/m
SELECTIVITY (IHF)	35 dB
IMAGE REJECTION	45 dB
IF REJECTION	55 dB
SIGNAL TO NOISE RATIO	35 dB
ANTENNA	Built in Loop Antenna

AMPLIFIER SECTION

RATED POWER OUTPUT (2-channel Driven)	30 watts per channel, minimum RMS, at 8 ohms from 20 to 20,000 Hz with no more than 0.05% total harmonic distortion.
POWER BANDWIDTH (IHF)	5 Hz to 40 kHz/8 ohms (Total harmonic distortion 0.1%)
SIGNAL TO NOISE RATIO	PHONO: 75 dB AUX/TAPE: 98 dB
CHANNEL SEPARATION (IHF)	PHONO: 50 dB (1 kHz) AUX/TAPE: 50 dB (1 kHz)
DAMPING FACTOR	more than 30 (1 kHz, 8 ohms)
INPUT SENSITIVITY/IMP	PHONO: 2.5 mV/100 kohms AUX/TAPE: 150 mV/47 kohms
OUTPUT LEVEL/IMP	TAPE REC: 150 mV/3 kohms
FREQUENCY RESPONSE	PHONO: 30 Hz to 15 kHz \pm 0.5 dB (RIAA) AUX/TAPE: 5 Hz to 80 kHz - 3 dB
TONE CONTROL	BASS: \pm 8 dB (100 Hz) TREBLE: \pm 8 dB (10 kHz)
SPEAKERS	A, B (4 to 16 ohms)/A + B (8 to 16 ohms)
POWER REQUIREMENTS	120V, 60 Hz for USA & Canada 220V, 50 Hz for European countries except UK 240V, 50 Hz for UK & Australia 110V/120V/220V/240V, 50/60 Hz switchable for other countries
DIMENSIONS	440(W) x 70(H) x 290(D) mm (17.3 x 2.8 x 11.4 inches)
WEIGHT	6 kg (13.2 lbs)

* For improvement purposes, specifications and design are subject to change without notice.

II. DISMANTLING OF UNIT

In case of trouble, etc. necessitating dismantling, please dismantle in the order shown in the photographs. Reassemble in reverse order.

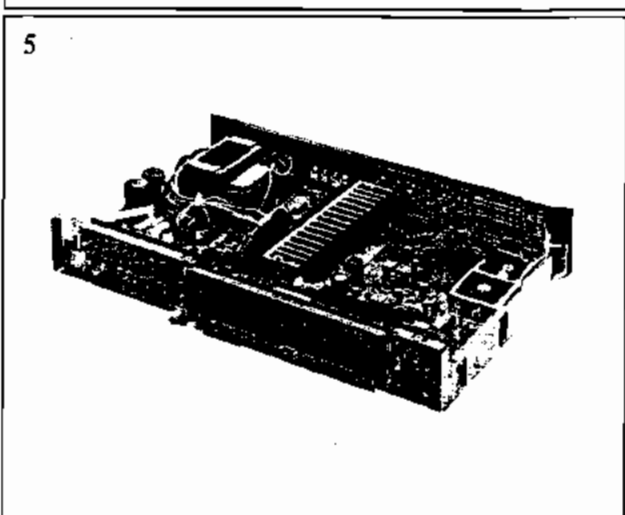
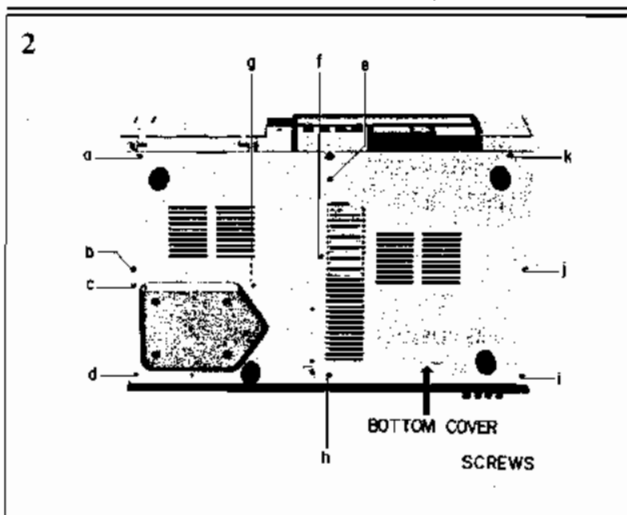
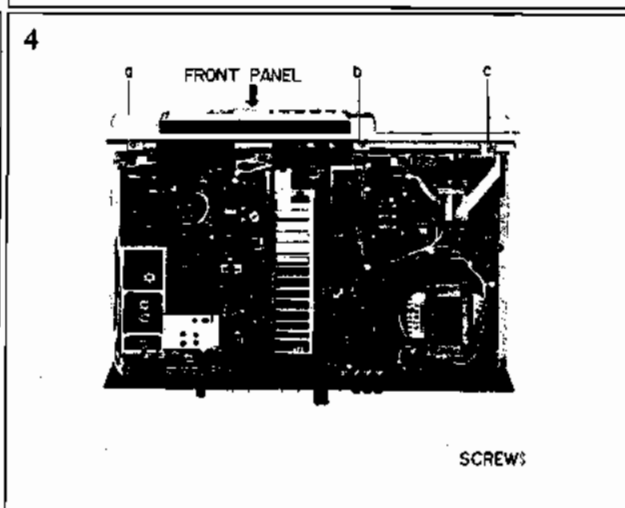
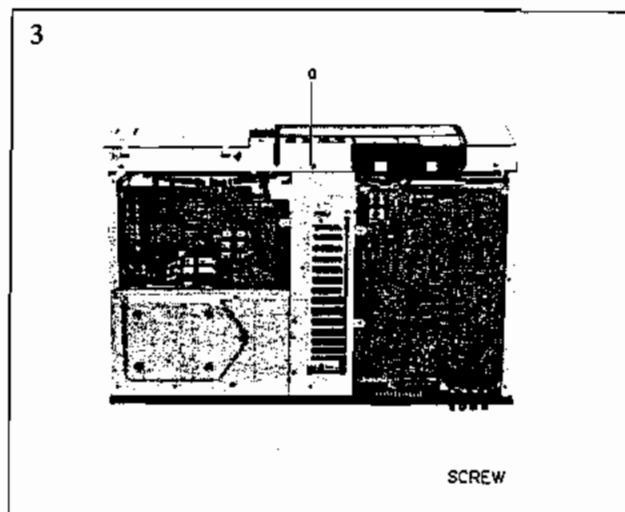
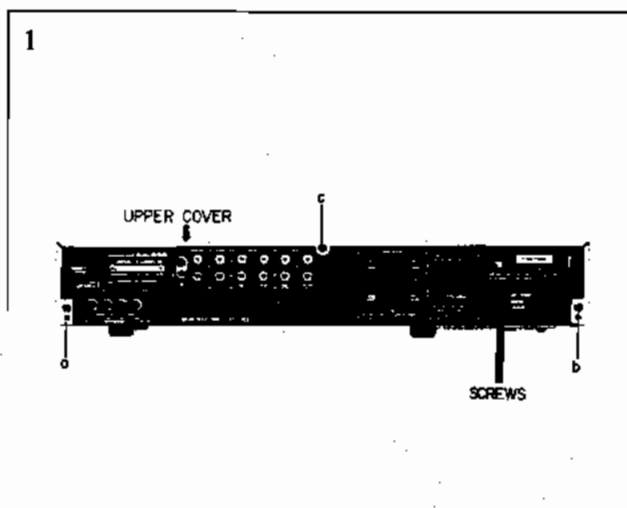

III. CONTROLS

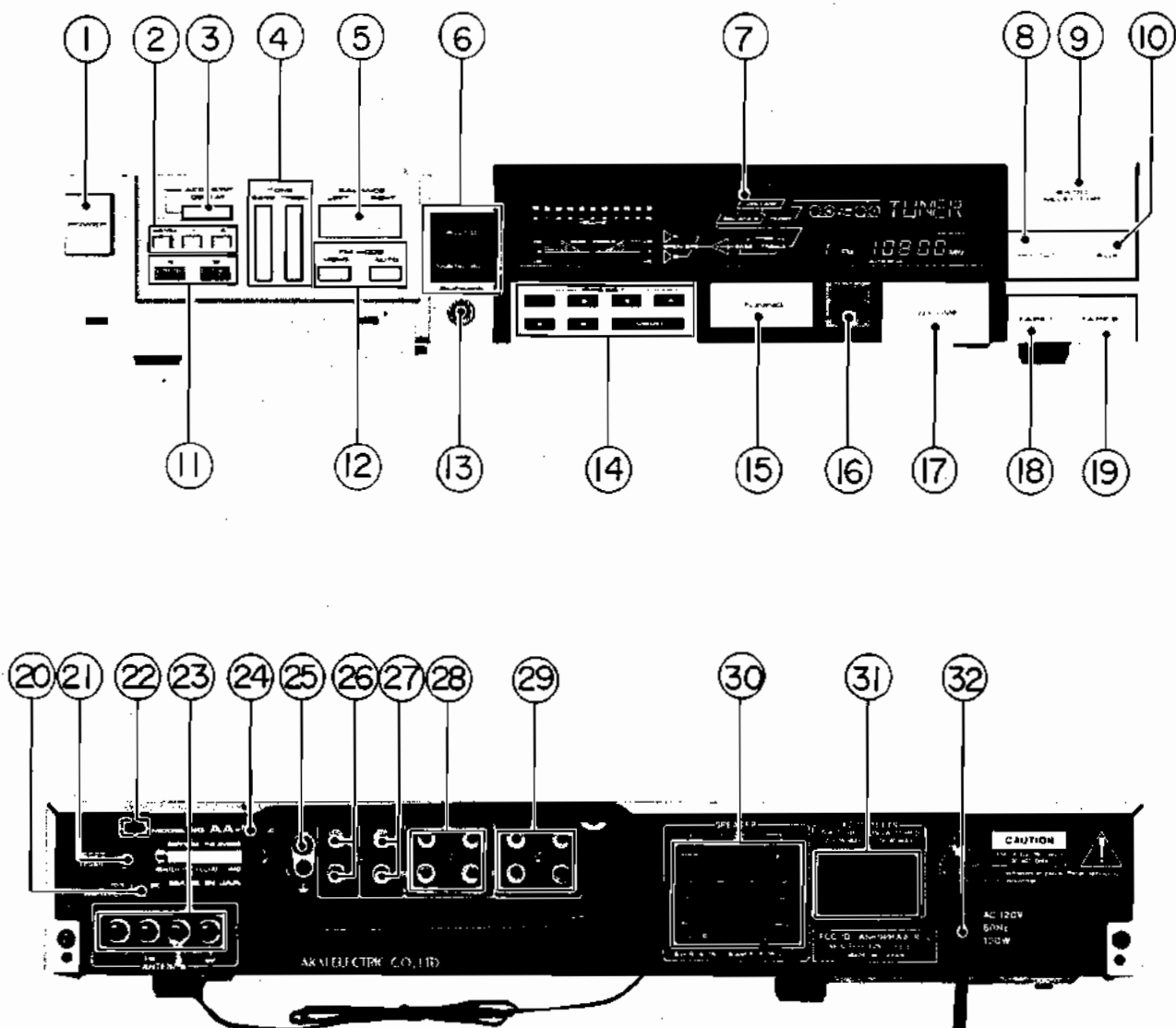

Fig. 2-1 Controls

- | | |
|-----------------------------|--|
| 1. POWER SWITCH | 17. VOLUME (UP/DOWN) BUTTON |
| 2. ACOUSTIC MEMORY BUTTONS | 18. TAPE 1 BUTTON |
| 3. DEFEAT BUTTON | 19. TAPE 2 BUTTON |
| 4. BASS AND TREBLE CONTROL | 20. AM STEP SELECTOR (Not on some models) |
| 5. BALANCE CONTROL | 21. RESET BUTTON |
| 6. TUNING MODE SELECTOR | 22. FM DE-EMPHASIS SELECTOR (Not on some models) |
| 7. FL DISPLAY | 23. ANTENNA TERMINALS |
| 8. PHONO BUTTON | 24. AM LOOP ANTENNA |
| 9. BAND SELECTOR | 25. GROUND TERMINAL |
| 10. AUX BUTTON | 26. PHONO JACKS |
| 11. SPEAKER SELECTOR | 27. AUX JACKS |
| 12. FM MODE SELECTOR | 28. TAPE 1 REC/PLAY JACKS |
| 13. PHONES JACK | 29. TAPE 2 REC/PLAY JACKS |
| 14. PRESET STATION BUTTON | 30. A AND B SPEAKER SYSTEM TERMINALS |
| 15. TUNING (UP/DOWN) BUTTON | 31. AC OUTLETS (Not on some models) |
| 16. FADER BUTTON | 32. POWER CORD |

IV. PRINCIPAL PARTS LOCATION

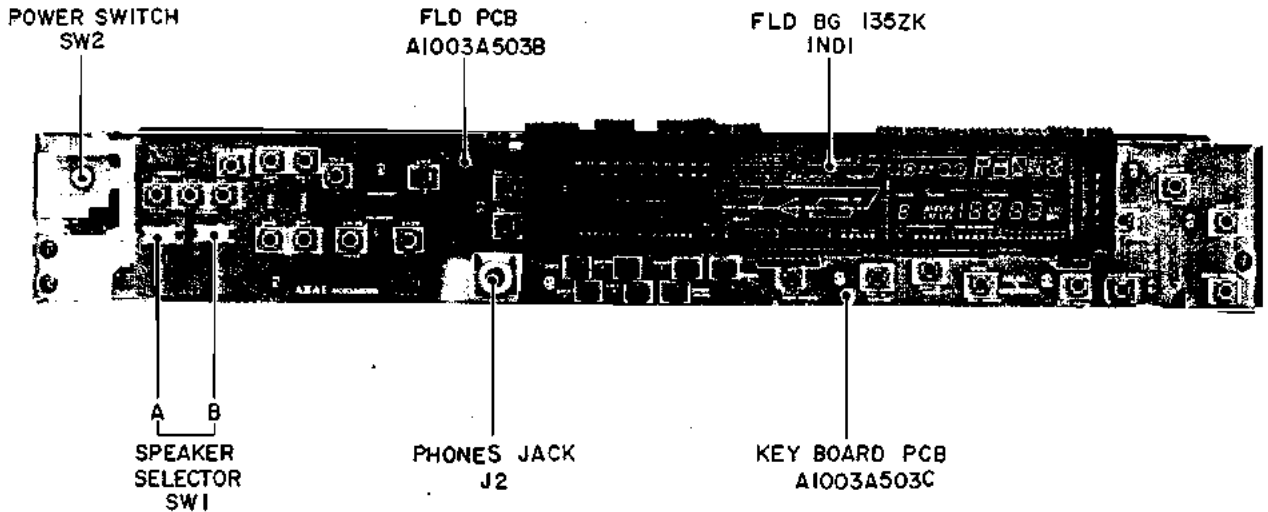

Fig. 2-2 Front View

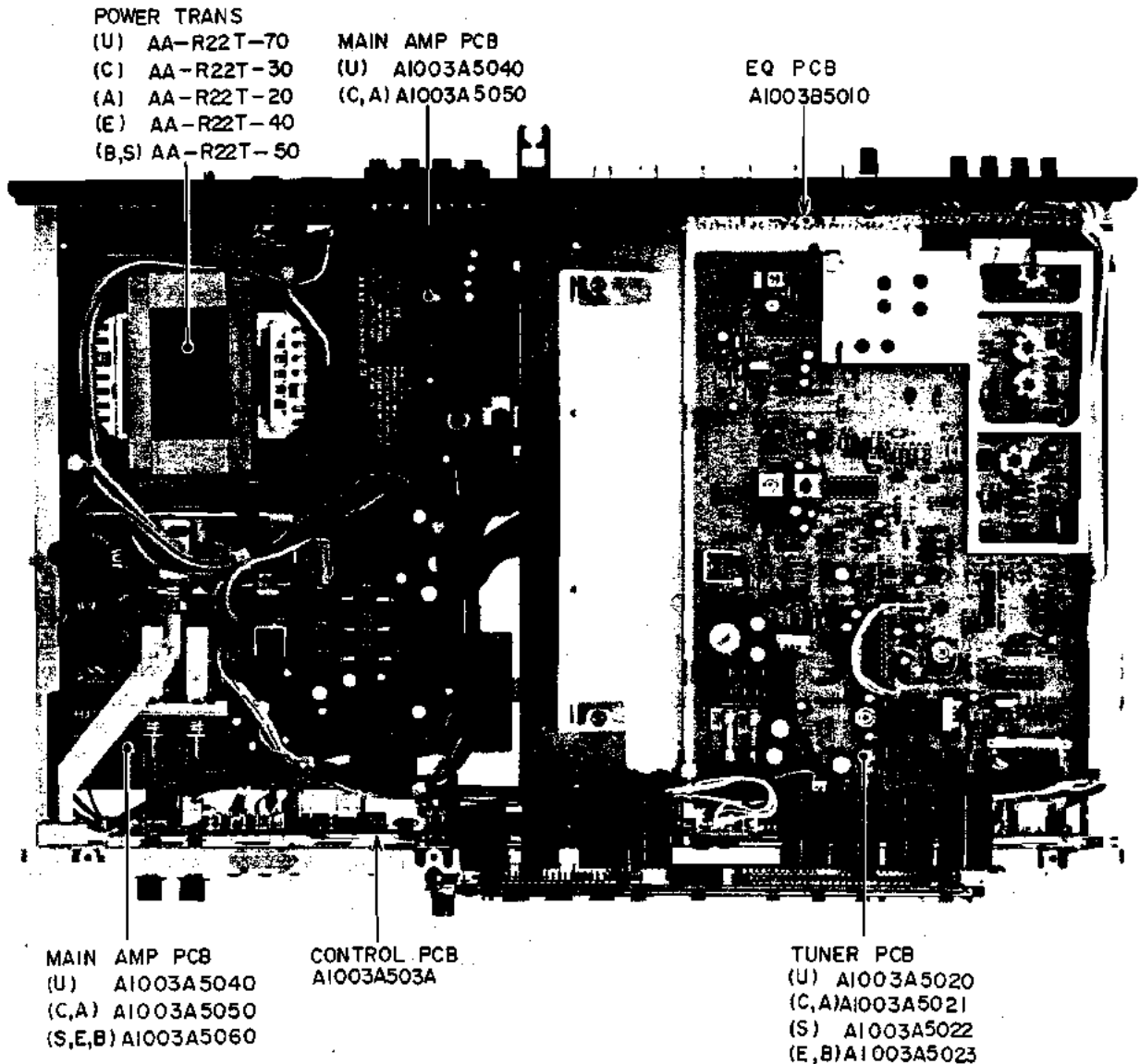

Fig. 2-3 Top View

V. CONVERSION

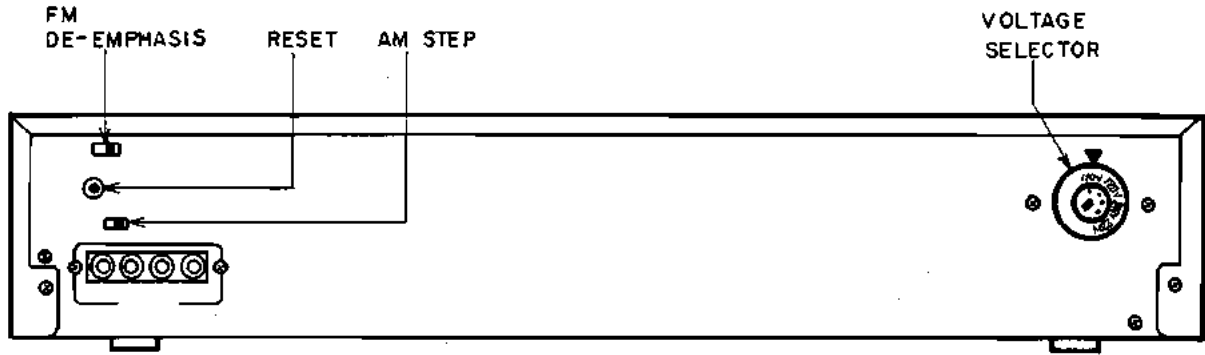

Fig. 2-4 Rear View

1. VOLTAGE CONVERSION

Models for Canada, USA and Australia are not equipped with this facility. Each machine is preset at the factory according to destination, but some machines can be set to 110V, 120V, 220V or 240V as required.

If your machine's voltage can be converted:

- 1) Disconnect the power cord from the power supply.
- 2) Turn the **VOLTAGE SELECTOR** located on the rear panel with a screwdriver until the correct voltage is indicated.

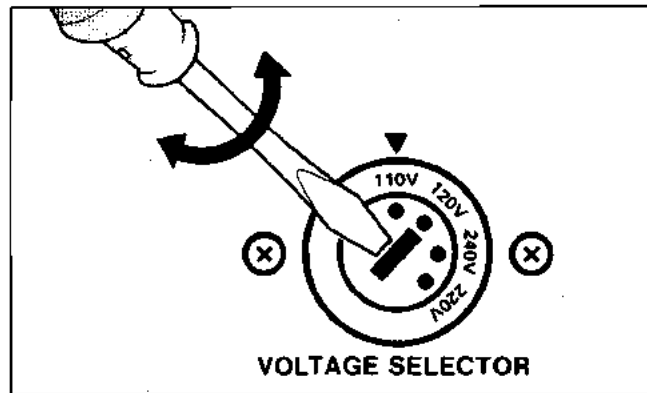

Fig. 2-5

2. FM DE-EMPHASIS SELECTOR (NOT ON SOME MODELS.)

Use this selector to de-emphasize an FM signal encoded with Dolby NR by an amount (50 μ s or 75 μ s) equal to the emphasis made at the broadcasting station.

Set this selector according to your area.

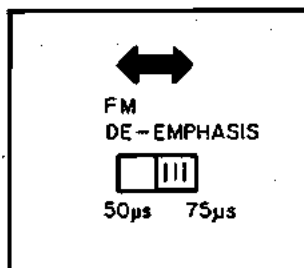

Fig. 2-6

3. AM STEP SELECTOR (NOT ON SOME MODELS.)

The Akai AA-R22 can scan the AM frequencies in steps of 9 kHz or 10 kHz. Set this selector according to the broadcasting frequencies in your area. After setting the AM STEP selector, turn on the Akai AA-R22 and then depress the RESET button.

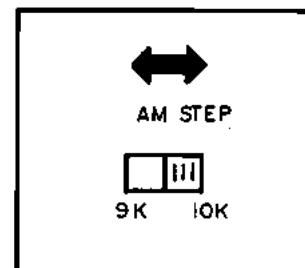

Fig. 2-7

VI. ADJUSTMENTS

1. CLOCK FREQUENCY ADJUSTMENT (Refer to Fig. 2-8)

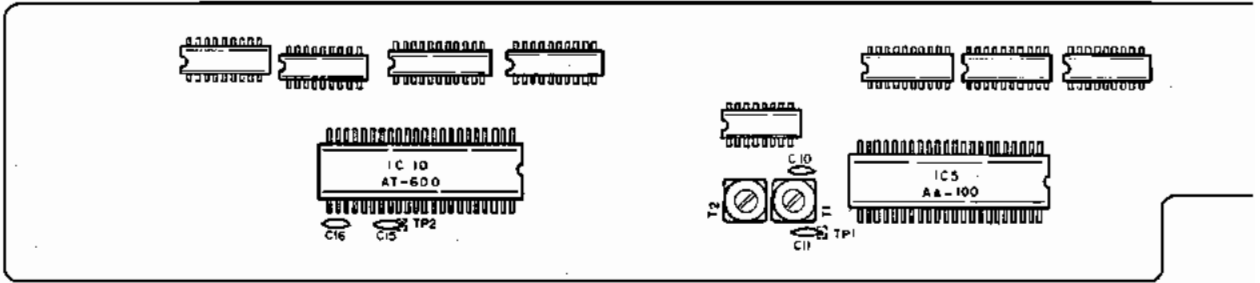

Fig. 2-8 Control PCB

- 1) Connect a Frequency Counter to TP1 (TP2).
- 2) Confirm that Frequency Counter reading is 400 kHz ~ 430 kHz.
- 3) Adjust T1 (Frequency of TP1) or T2 (Frequency of TP2), if adjustment is necessary.

2. TUNER ADJUSTMENT

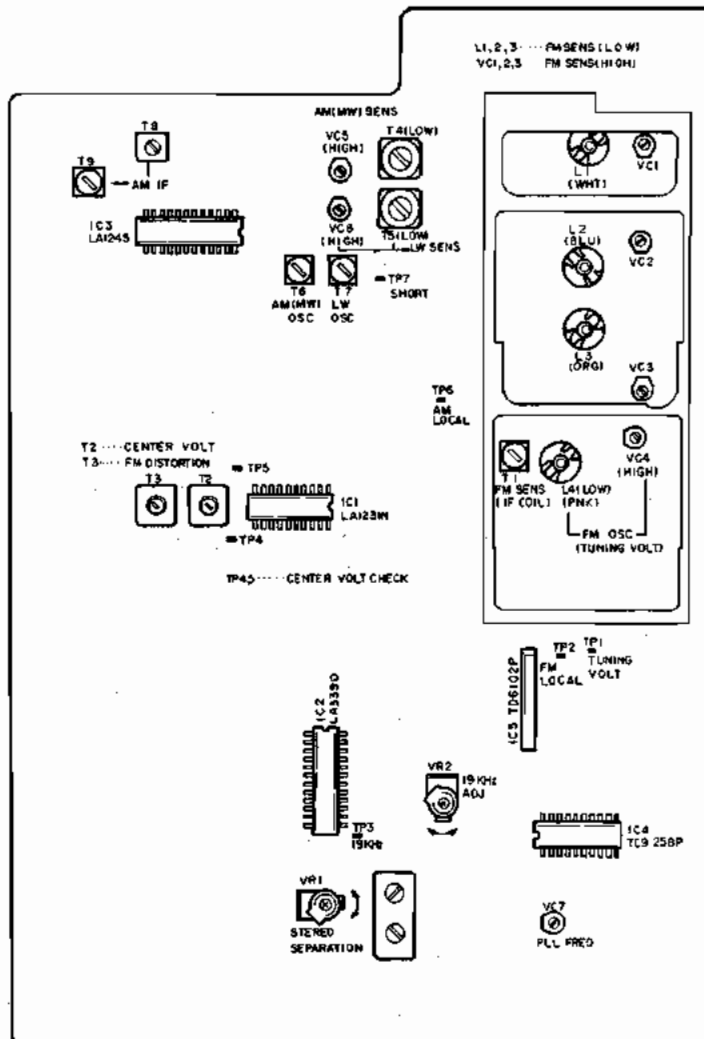

Fig. 2-9 Tuner PCB

1) AM (AA-R22L : MW) SECTION ADJUSTMENT (Refer to Figs. 2-9, 10)

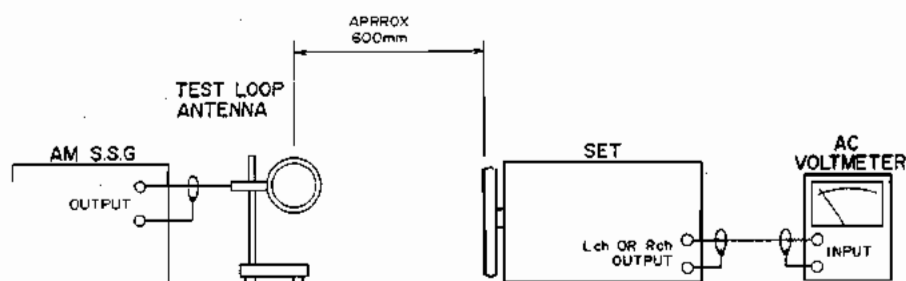

Fig. 2-10 Instrument Connection for AM (MW, LW) Section Adjustment

Step	Adjustment Item	Adjustment Point	Result	Remarks
1	PLL Frequency	VC7	Digital Display indicating Freq. +10.7 MHz	Band SW to FM Connect Frequency Counter between TP2 and GND (See NOTE)
2	AM (MW) OSC	T6	710 ± 1 kHz (AA-R22) 730 ± 1 kHz (AA-R22L)	Band SW to AM (MW). Connect TP7 to GND. Connect Frequency Counter between TP6 and GND.
3	AM IF	T8, 9	Max Output	1,000 kHz (1008 kHz), 50 dB, 400 Hz (30%) input.
4	Low Range Sensitivity 600 kHz (603 kHz)	T4	Max Output Distortion Factor: Less than 10%	600 kHz (603 kHz), 50 dB, 400 Hz (30%) input.
5	High Range Sensitivity 1,400 kHz (1,404 kHz)	VC5	Max Output Distortion Factor: Less than 10%	1,400 kHz (1,404 kHz), 50 dB, 400 Hz (30%)
6				Readjust in Steps 4 and 5.

NOTE: Digital display frequency +10.7 MHz means that when the display frequency of Digital Display is 100 MHz, it should be adjust to 110.7 MHz.

2) LW SECTION ADJUSTMENT (AA-R22L only) (Refer to Figs. 2-9, 10)

Step	Adjustment Item	Adjustment Point	Result	Remarks
1	LW OSC	T7	530 kHz ± 1 kHz	Band SW to LW. Connect TP7 to GND. Connect a Frequency Counter between TP6 and GND.
2	Low Range Sensitivity 155 kHz	T5	Max Output Distortion Factor: Less than 10%	155 kHz, 50 dB, 400 Hz (30%) input.
3	High Range Sensitivity 299 kHz	VC6	Max Output Distortion Factor: Less than 10%	299 kHz, 50 dB, 400 Hz (30%) input.
4				Readjust in Steps 2 and 3.

3) FM SECTION ADJUSTMENT (Refer to Figs. 2-9, 11)

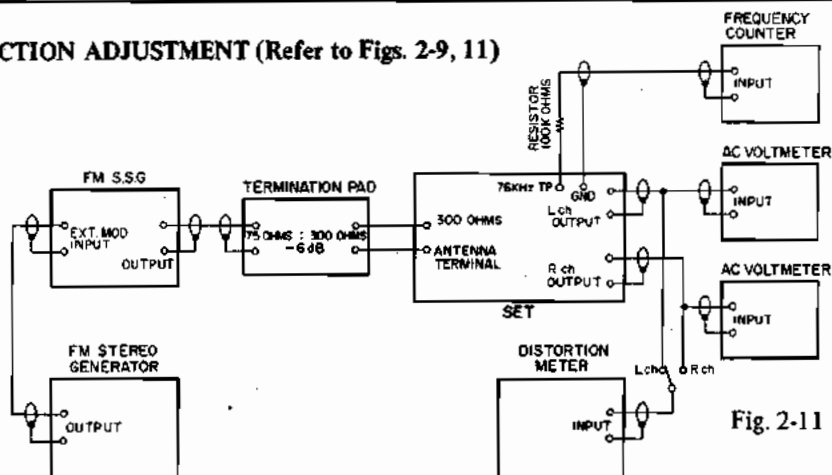

Fig. 2-11 Instruments Connection for FM Section Adjustment

Step	Adjustment Item	Adjustment Point	Result	Remarks
1	FM Tuning Voltage (LOW)	L4	3.2V	1) Band SW to FM 2) Display to 88 MHz. 3) Connect a digital Voltmeter between TP1 and GND
2	FM Tuning Voltage (HIGH)	VC4	20V	Display to 108 MHz same as above.
3				Readjust in Steps 1 and 2.
4	PLL Frequency	VC7	Digital Display Indicating Frequency +10.7 MHz	Connect a Frequency Counter between TP2 and GND (See NOTE 1)
5	Low Range Sensitivity 88.0 MHz	L1, 2, 3 T1	Distortion Factor: Less than 3%	1) Mode SW to MONO. 2) 88 MHz less than 8 dB, 1 kHz (mono 100%) input.
6	High Range Sensitivity 108 MHz	VC1, 2, 3	Distortion Factor: Less than 3%	108 MHz, less than 8 dB, 1 kHz (mono 100%) input.
7				Readjust in Steps 5 and 6.
8	Center Voltage	T2	Centered Tuning Meter Indication	1) Connect a Tuning Meter between TP4 and TP5. (See NOTE 2) 2) Tunes only noise without interference from broadcasting.
9	Distortion Factor	T3	Distortion Factor: Less than 0.3%	98 MHz, 60 dB, 1 kHz (mono 100%) input.
10				Readjust in Steps 8 and 9.
11	MPX Free Running Frequency	VR2	19 kHz \pm 50 Hz	Mode SW to FM Auto Connect a Frequency Counter between TP3 and GND. 98 MHz non-modulation signal input.
12	Stereo Separation	VR1	More than 40 dB	98 MHz, 60 dB, 1 kHz (Stereo 100%) Lch (Rch) input Minimum output of Rch (Lch).

NOTES: 1. Digital display frequency +10.7 MHz means that when the display frequency of Digital Display is 100 MHz, it should be adjusted to 110.7 MHz.
2. For the Center Meter should be used the tuning meter and the like available as a part of the other models.

VII. CLASSIFICATION OF VARIOUS P.C BOARDS

I. P.C BOARD TITLES AND IDENTIFICATION NUMBERS

1) Model AA-R22

P.C Board TITLE	P.C Board Number	Notes
EQ P.C Board	A1003B5010	
Tuner P.C Board	A1003A5020	U
Tuner P.C Board	A1003A5021	C, A
Tuner P.C Board	A1003A5022	S
Control P.C Board	A1003A503A	
FLD P.C Board	A1003A503B	
KEY P.C Board	A1003A503C	
Main Amp P.C Board	A1003A5040	U
Main Amp P.C Board	A1003A5050	C, A
Main Amp P.C Board	A1003A5060	S
Head Phone P.C Board	A1003A504B	U
Head Phone P.C Board	A1003A505B	C, A
Head Phone P.C Board	A1003A506B	S
IC P.C Board	A1003A504C	U
IC P.C Board	A1003A505C	C, A
IC P.C Board	A1003A 506C	S

2) Model AA-R22L

P.C Board Title	P.C Board Number	Notes
EQ P.C Board	A1003B5010	
Tuner P.C Board	A1003A5023	
Control P.C Board	A1003A503A	
FLD P.C Board	A1003A503B	
KEY P.C Board	A1003A503C	
Main Amp P.C Board	A1003A5060	
Head Phone P.C Board	A1003A506B	
IC P.C Board	A1003A506C	

2. COMPOSITION OF VARIOUS P.C BOARDS

1) MODEL AA-R22 TUNER P.C BOARD A1003A5020, 21, 22 (3ED)

LOCATION OF COMPONENTS

TR

TR1.....A4
 TR2.....B4
 TR3,4.....C4
 TR5.....B3
 TR6,7.....C1
 TR8to10....D3
 TR18.....B1
 TR21.....D2
 TR22.....C1
 TR23to25...C3
 TR26,27....C4
 TR30.....C1

IC

IC1.....B2
 IC2.....C,D2
 IC3.....A1,2
 IC4.....D4
 IC5.....C4

TERMINAL

① to ⑤.....D1
 J1.....D4
 J2.....D3
 J3.....C2
 J4.....C,D2

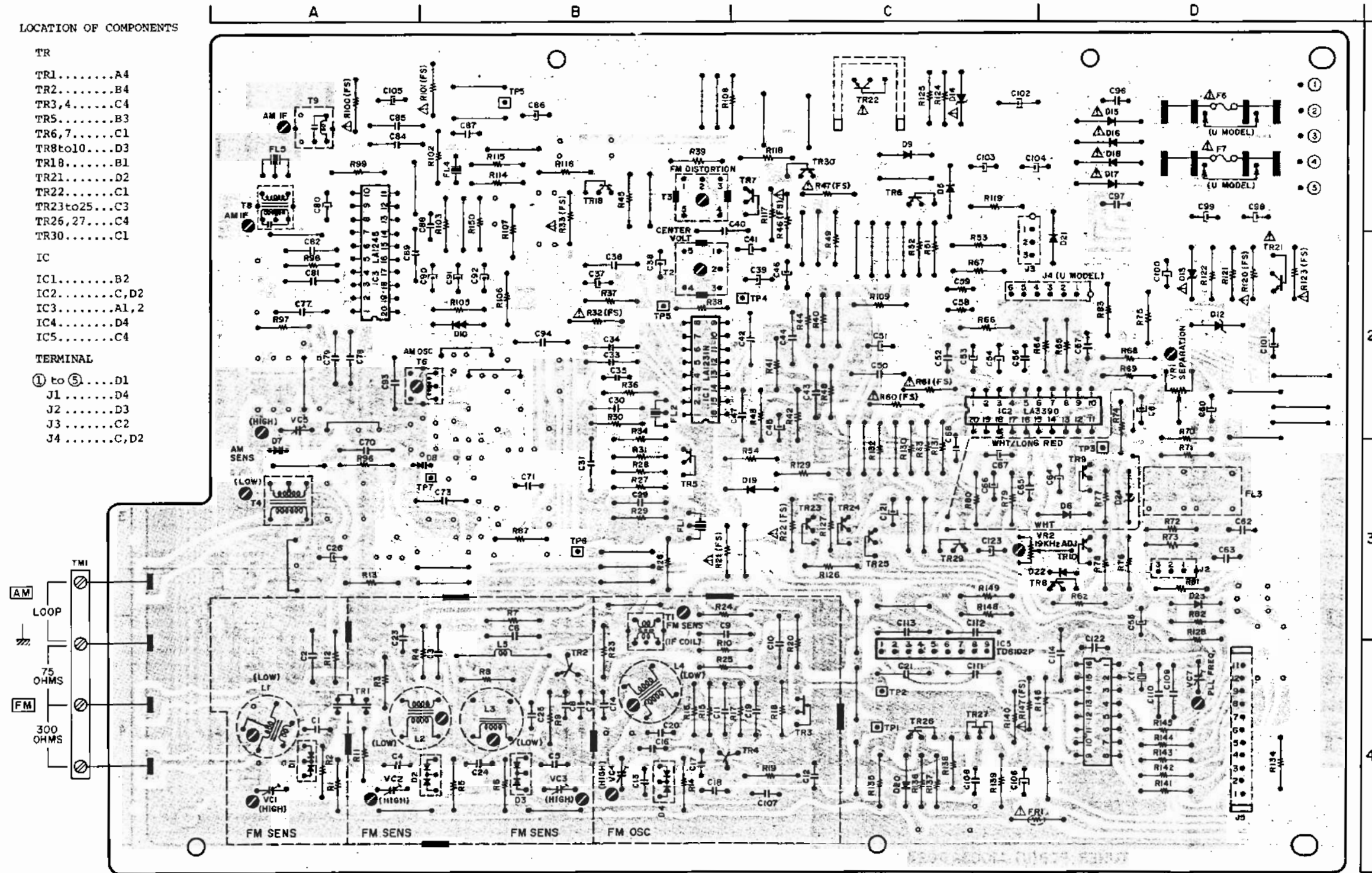

TUNER PCB(U) A1003A5020
 (C,A) A1003A5021
 (S) A1003A5022

- TR1 ----- 3SK73(Y)
- TR2 ----- 2SC2999(C,D)
- TR3 ----- 2SK212(D,E)
- TR4 ----- 2SC930(E,F)
- TR5 ----- 2SC3000(E,F)
- TR6 to 8, 10, 18,
 24 to 26, 30 -- 2SC536K-NP(E,F,G)
- TR9, 23 ----- 2SA608K-NP(E,F,G)
- TR21 ----- 2SD571(L,M)
- TR22 ----- 2SD313HP(E,F)
- TR27 ----- 2SK223(E,F)

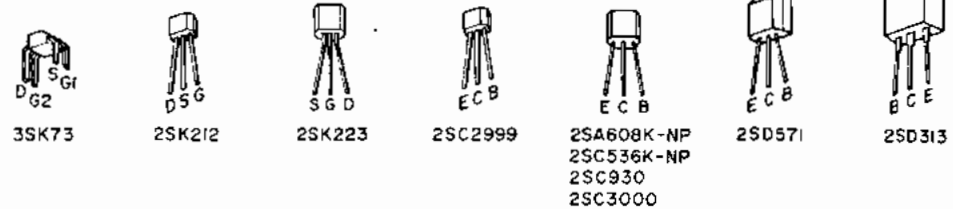

WARNING: ⚠ INDICATES SAFETY CRITICAL COMPONENTS FOR CONTINUED SAFETY. REPLACE SAFETY CRITICAL COMPONENTS ONLY WITH MANUFACTURER'S RECOMMENDED PARTS.
 AVERTISSEMENT: ⚠ IL INDIQUE LES COMPOSANTS CRITIQUES DE SÉCURITÉ POUR MAINTENIR LE DEGRÉ DE SÉCURITÉ DE L'APPAREIL. NE REMPLACER QUE DES PIÈCES RECOMMANDÉES PAR LE FABRICANT.

2) MODEL AA-R22L TUNER P.C BOARD A1003A5023 (3ED)

LOCATION OF COMPONENTS
TR

- TR1.....A4
- TR2.....B4
- TR3,4.....C4
- TR5.....B3
- TR6,7.....C1
- TR8to10....D3
- TR11.....A3
- TR12,13....B2
- TR14to16...B3
- TR17.....A2
- TR18.....B1
- TR19,20....D3
- TR21.....D2
- TR22.....C1
- TR23to25...C3
- TR26,27....C4
- TR28.....B3
- TR30.....C1

IC

- IC1.....B2
- IC2.....C,D2
- IC3.....A1,2
- IC4.....D4
- IC5.....C4

TERMINAL

- ① to ⑤.....D1
- J1.....D4
- J2.....D3
- J3.....C2

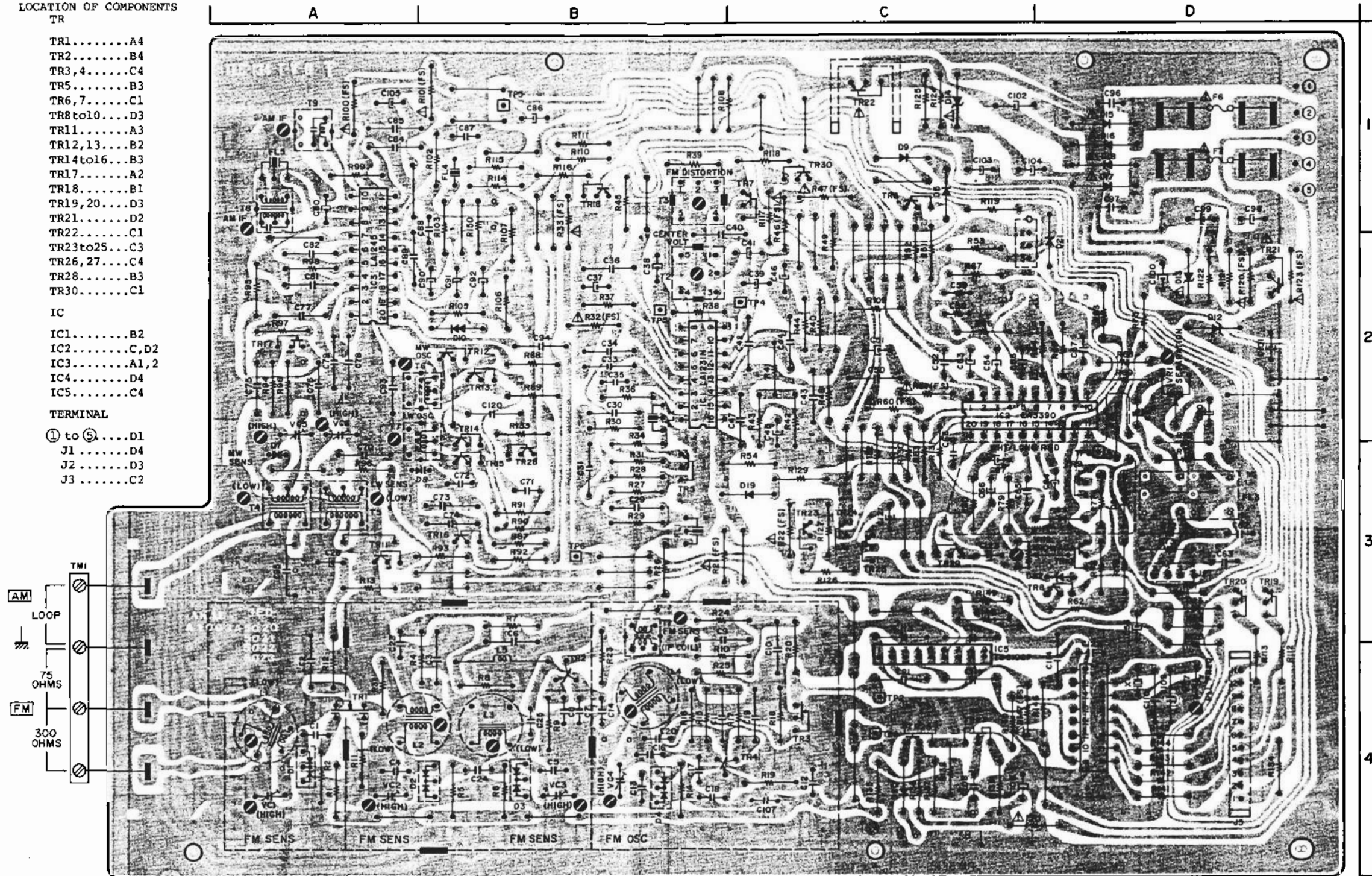

TUNER PCB(U) A1003A5023

- TR1 ----- 3SK73 (Y)
- TR2 ----- 2SC2999 (C,D)
- TR3 ----- 2SK212 (D,E)
- TR4 ----- 2SC930 (E,F)
- TR5 ----- 2SC3000 (E,F)
- TR6 to 8, 10, 16, 18 to 20
24 to 26, 28, 30 - 2SC536K-NP (E,F,G)
- TR9, 12 to 15, 23 - 2SK608K-NP (E,F,G)
- TR11 ----- 2SC2878 (A,B)
- TR17 ----- 2SK1910 (Y)
- TR21 ----- 2SD571 (L,M)
- TR22 ----- 2SD313HP (E,F)
- TR27 ----- 2SK223 (E,F)

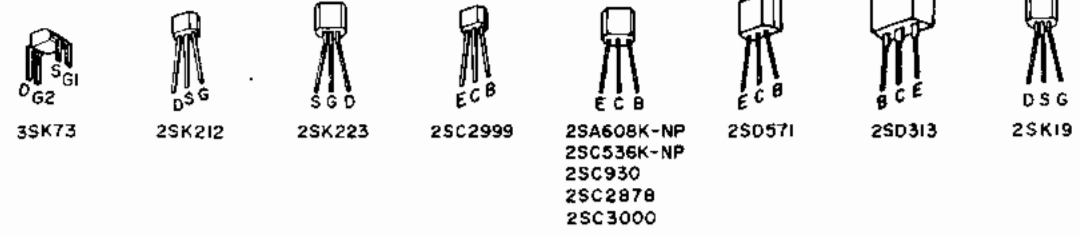

WARNING: Δ INDICATES SAFETY CRITICAL COMPONENTS FOR CONTINUED SAFETY. REPLACE SAFETY CRITICAL COMPONENTS ONLY WITH MANUFACTURER'S RECOMMENDED PARTS.
AVERTISSEMENT: Δ IL INDIQUE LES COMPOSANTS CRITIQUES DE SÉCURITÉ. POUR MAINTENIR LE DEGRÉ DE SÉCURITÉ DE L'APPAREIL, NE REMPLACER QUE DES PIÈCES RECOMMANDÉES PAR LE FABRICANT

3) MODEL AA-R22/L CONTROL P.C BOARD A1003A503A(2ED), FLD P.C BOARD A1003A503B and KEY P.C BOARD A1003A503C

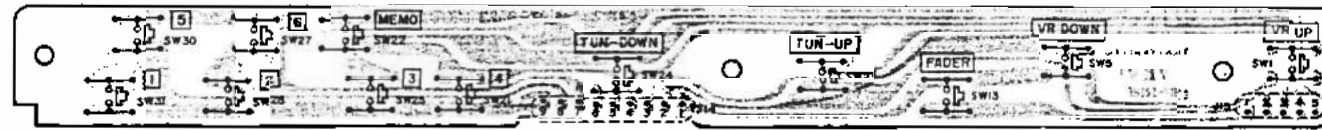

KEY PCB A1003A503C

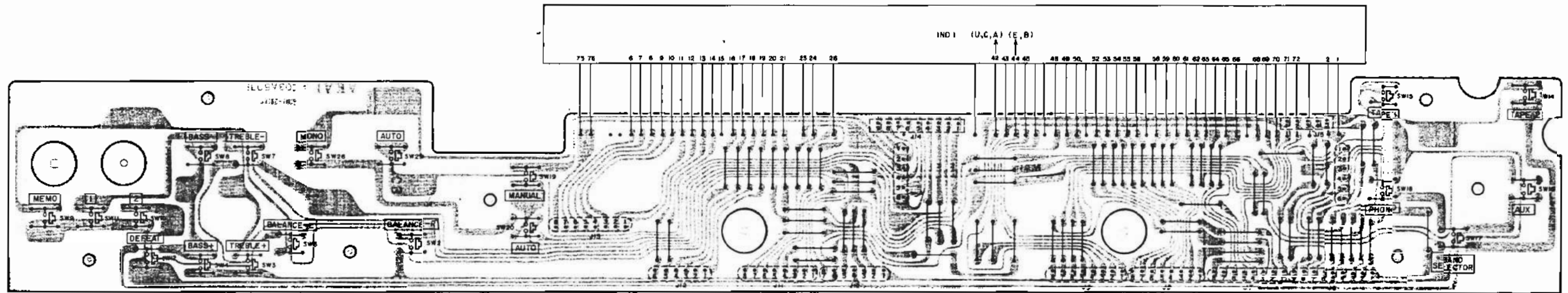

FLD PCB A1003A503B

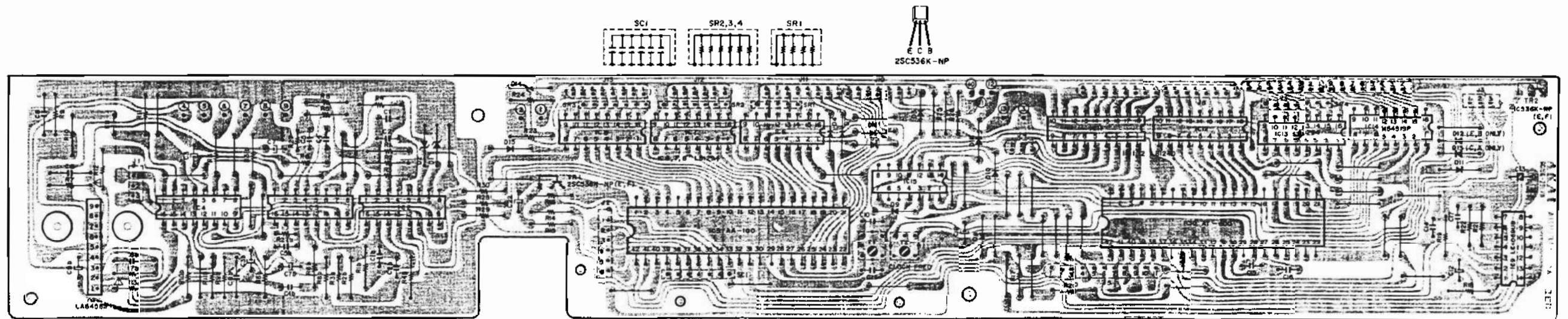

CONTROL PCB A1003A503A

WARNING: Δ INDICATES SAFETY CRITICAL COMPONENTS. FOR CONTINUED SAFETY, REPLACE SAFETY CRITICAL COMPONENTS ONLY WITH MANUFACTURER'S RECOMMENDED PARTS.
 AVERTISSEMENT: Δ IL INDIQUE LES COMPOSANTS CRITIQUES DE SÉCURITÉ. POUR MAINTENIR LE DEGRÉ DE SÉCURITÉ DE L'APPAREIL, NE REMPLACER QUE DES PIÈCES RECOMMANDÉES PAR LE FABRICANT.

4) MODEL AA-R22/L MAIN AMP P.C BOARD A1003A5040. 50, 60(3ED), HEADPHONE P.C BOARD A1003A504B, 5B, 6B and IC P.C BOARD A1003A504C, 5C, 6C

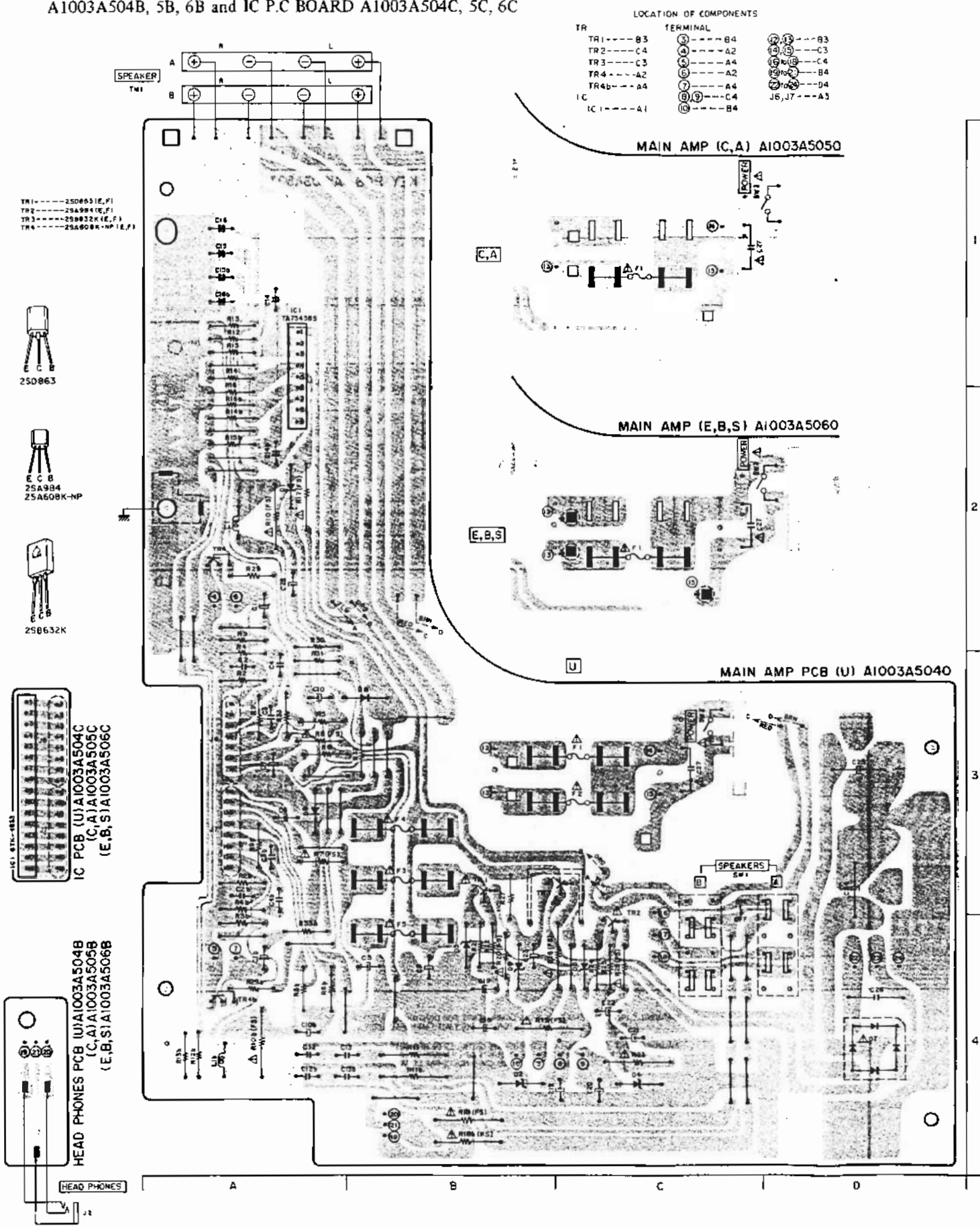

5) MODEL AA-R22/L EQ P.C BOARD A1003B5010(2ED)

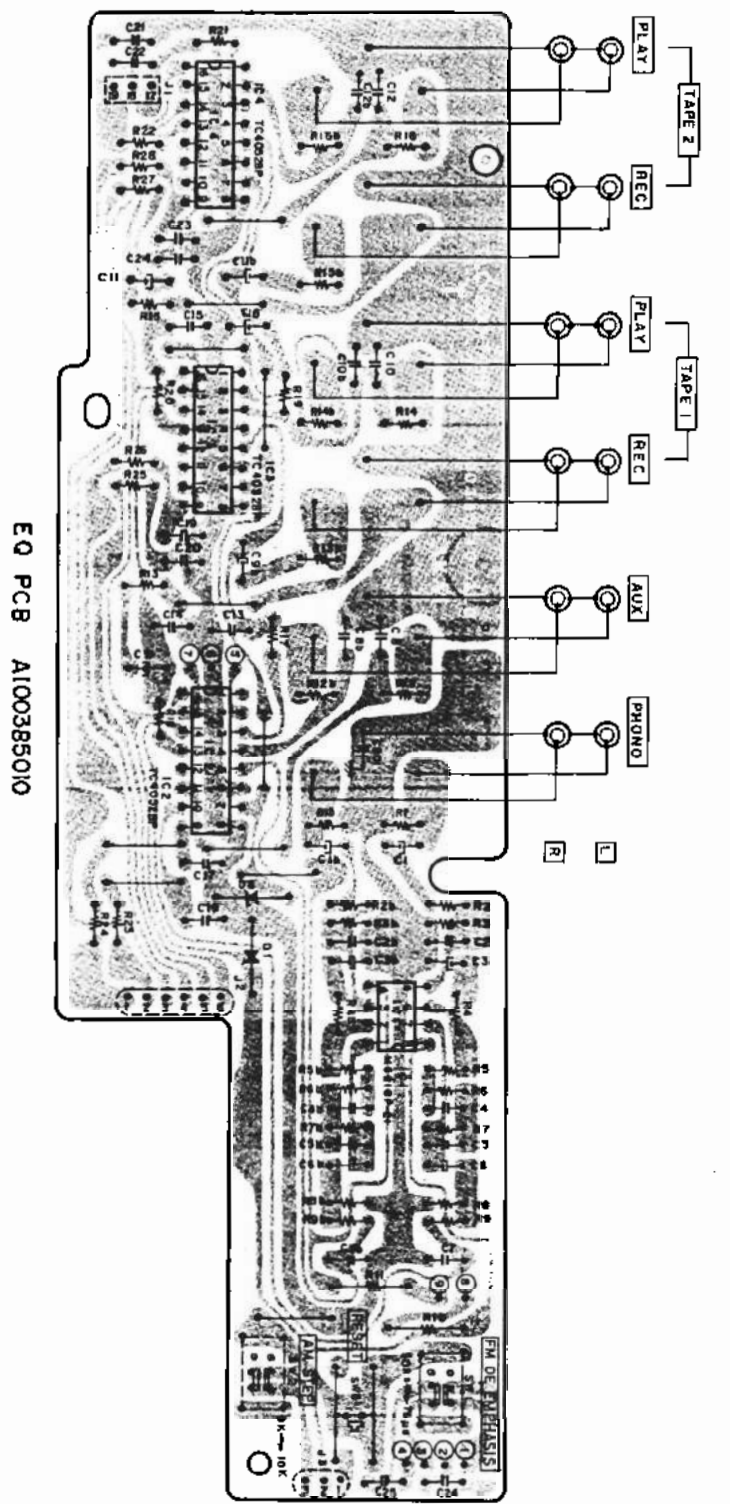

WARNING: INDICATES SAFETY CRITICAL COMPONENTS FOR CONTINUED SAFETY. CRITICAL COMPONENTS ONLY WITH MANUFACTURER'S RECOMMENDED PARTS.
 AVERTISSEMENT: ALL INDIQUE LES COMPOSANTS CRITIQUES DE SÉCURITÉ. RECOMMANDÉES PARTS.
 POUR MAINTENIR LE DEGRÉ DE SÉCURITÉ DE L'APPAREIL, NE REMPLACER QUE DES PIÈCES RECOMMANDÉES PAR LE FABRICANT.

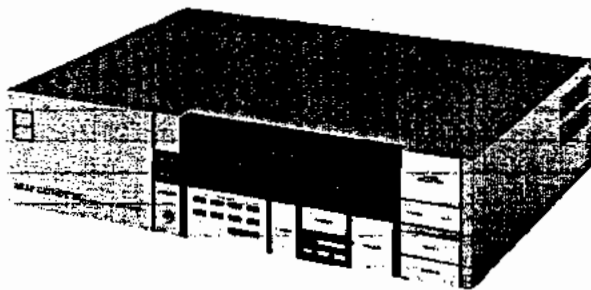

AA-R32/L

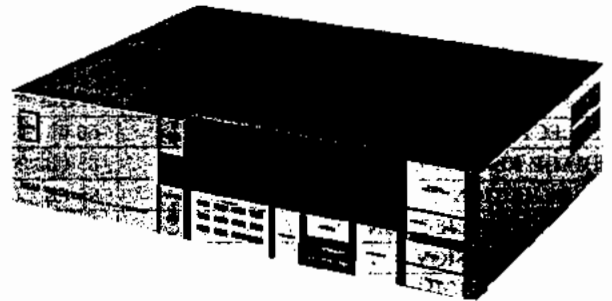

AA-R42

SECTION 3

SERVICE MANUAL

MODEL AA-R32/L, AA-R42

TABLE OF CONTENTS

I.	SPECIFICATIONS	48
1.	MODEL AA-R32/L	48
2.	MODEL AA-R42	49
II.	DISMANTLING OF UNIT	50
III.	CONTROLS	51
IV.	PRINCIPAL PARTS LOCATION	53
1.	MODEL AA-R32/L	53
2.	MODEL AA-R42	54
V.	CONVERSION	55
1.	VOLTAGE CONVERSION	55
2.	FM DE-EMPHASIS SELECTOR	55
3.	AM STEP SELECTOR	55
VI.	ADJUSTMENTS	56
1.	CLOCK FREQUENCY ADJUSTMENT	56
2.	MODEL AA-R32/L, AA-R42 TUNER ADJUSTMENT	57
3.	MODEL AA-R32/L, AA-R42 POWER LEVEL METER SENSITIVITY ADJUSTMENT	60
VII.	CLASSIFICATION OF VARIOUS P.C BOARDS	61
1.	MODEL AA-R32/L P.C BOARD TITLES AND IDENTIFICATION NUMBERS	61
2.	MODEL AA-R42 P.C BOARD TITLES AND IDENTIFICATION NUMBERS	62
3.	MODEL AA-R32/L COMPOSITION OF VARIOUS P.C BOARDS	63
4.	MODEL AA-R42 COMPOSITION OF VARIOUS P.C BOARD	68

For basic adjustments, measuring methods, and operating principles, refer to GENERAL TECHNICAL MANUAL.

I. SPECIFICATIONS

I. MODEL AA-R32/L

FM TUNER SECTION

FREQUENCY RANGE	87.4 MHz to 108.1 MHz
USABLE SENSITIVITY (30 dB) (IHF)	11.2 dBf
50 dB QUIETING SENSITIVITY (IHF)	16.2 dBf (MONO) 37.2 dBf (STEREO)
CAPTURE RATIO	1.5 dB
SELECTIVITY (IHF)	60 dB
IMAGE REJECTION	85 dB
IF REJECTION	90 dB
SPURIOUS REJECTION	90 dB
AM SUPPRESSION	60 dB
SIGNAL TO NOISE RATIO (IHF)	MONO: 75 dB STEREO: 65 dB
HARMONIC DISTORTION	MONO: 0.1% STEREO: 0.3% (at 100% modulation)
STEREO SEPARATION	45 dB (1 kHz), 35 dB (30 Hz to 15 kHz)
FREQUENCY RESPONSE	30 Hz to 12 kHz \pm 0.5 dB
SUB CARRIER SUPPRESSION	60 dB
ANTENNA INPUT IMPEDANCE	300 ohms balanced, 75 ohms unbalanced

AM (MW for AA-R32L) TUNER SECTION

FREQUENCY RANGE	530 kHz to 1610 kHz (for 10 kHz steps) 522 kHz to 1611 kHz (for 9 kHz steps)
USABLE SENSITIVITY (IHF)	300 μ V/m
SELECTIVITY (IHF)	35 dB
IMAGE REJECTION	40 dB
IFF REJECTION	55 dB
SIGNAL TO NOISE RATIO	45 dB
ANTENNA	Built in Loop Antenna

LW TUNER SECTION (AA-R32L only)

FREQUENCY RANGE	137 kHz to 362 kHz
USABLE SENSITIVITY (IHF)	800 μ V/m
SELECTIVITY (IHF)	35 dB
IMAGE REJECTION	45 dB
IF REJECTION	55 dB
SIGNAL TO NOISE RATIO	35 dB
ANTENNA	Built in Loop Antenna

AMPLIFIER SECTION

RATED POWER OUTPUT (2-channel Driven)	45 watts per channel, minimum RMS, at 8 ohms from 20 to 20,000 Hz with no more than 0.01% total harmonic distortion.
POWER BANDWIDTH (IHF)	5 Hz to 40 kHz/8 ohms (Total harmonic distortion 0.1%)
SIGNAL TO NOISE RATIO	PHONO: 75 dB AUX/TAPE: 98 dB
CHANNEL SEPARATION (IHF)	PHONO: 60 dB (1 kHz) AUX/TAPE: 60 dB (1 kHz)
DAMPING FACTOR	more than 35 (1 kHz, 8 ohms)
INPUT SENSITIVITY/IMP	PHONO: 2.5 mV/100 kohms AUX/TAPE: 150 mV/47 kohms
OUTPUT LEVEL/IMP	TAPE REC: 150 mV/3 kohms
FREQUENCY RESPONSE	PHONO: 30 Hz to 15 kHz \pm 0.5 dB (RIAA) AUX/TAPE: 5 Hz to 100 kHz - 3 dB
TONE CONTROL	BASS: \pm 8 dB (100 Hz) TREBLE: \pm 8 dB (10 kHz)
SPEAKERS	A, B (4 to 16 ohms)/A + B (8 to 16 ohms)
POWER REQUIREMENTS	120V, 60 Hz for USA & Canada 220V, 50 Hz for European countries except UK 240V, 50 Hz for UK & Australia 110V/120V/220V/240V, 50/60 Hz switchable for other countries
DIMENSIONS	440(W) x 100(H) x 320(D) mm (17.3 x 3.9 x 12.6 inches)
WEIGHT	9 kg (19.8 lbs)

* For improvement purposes, specifications and design are subject to change without notice.

2. MODEL AA-R42

FM TUNER SECTION

FREQUENCY RANGE	87.4 MHz to 108.1 MHz
USABLE SENSITIVITY (30 dB) (IHF)	11.2 dBf
50 dB QUIETING SENSITIVITY (IHF)	16.2 dBf (MONO) 37.2 dBf (STEREO)
CAPTURE RATIO	1.5 dB
SELECTIVITY (IHF)	60 dB
IMAGE REJECTION	85 dB
IF REJECTION	90 dB
SPURIOUS REJECTION	90 dB
AM SUPPRESSION	60 dB
SIGNAL TO NOISE RATIO (IHF)	MONO: 75 dB STEREO: 65 dB
HARMONIC DISTORTION	MONO: 0.1% STEREO: 0.3% (at 100% modulation)
STEREO SEPARATION	45 dB (1 kHz), 35 dB (30 Hz to 15 kHz)
FREQUENCY RESPONSE	30 Hz to 12 kHz \pm 0.5 dB
SUB CARRIER SUPPRESSION	60 dB
ANTENNA INPUT IMPEDANCE	300 ohms balanced, 75 ohms unbalanced

AM TUNER SECTION

FREQUENCY RANGE	530 kHz to 1610 kHz (for 10 kHz steps) 522 kHz to 1611 kHz (for 9 kHz steps)
USABLE SENSITIVITY (IHF)	300 μ V/m
SELECTIVITY (IHF)	35 dB
IMAGE REJECTION	40 dB
IFF REJECTION	55 dB
SIGNAL TO NOISE RATIO	45 dB
ANTENNA	Built in Loop Antenna

AMPLIFIER SECTION

RATED POWER OUTPUT (2-channel Driven)	60 watts per channel, minimum RMS, at 8 ohms from 20 to 20,000 Hz with no more than 0.01% total harmonic distortion.
POWER BANDWIDTH (IHF)	5 Hz to 70 kHz/8 ohms (Total harmonic distortion 0.1%)
SIGNAL TO NOISE RATIO	PHONO MC: 70 dB PHONO MM: 85 dB AUX/TAPE: 98 dB
CHANNEL SEPARATION (IHF)	PHONO: 65 dB (1 kHz) AUX/TAPE: 60 dB (1 kHz)
DAMPING FACTOR	more than 35 (1 kHz, 8 ohms)
INPUT SENSITIVITY/IMP	PHONO MC: 0.25 mV/100 ohms PHONO MM: 2.5 mV/47 kohms AUX/TAPE: 150 mV/47 kohms
OUTPUT LEVEL/IMP	TAPE REC: 150 mV/3 kohms
FREQUENCY RESPONSE	PHONO: 30 Hz to 15 kHz \pm 0.5 dB (RIAA) AUX/TAPE: 5 Hz to 100 kHz \pm 3 dB
tone CONTROL	BASS: \pm 8 dB (100 Hz) TREBLE: \pm 8 dB (10 kHz)
FILTER	Subsonic: 18 Hz, -6 dB/oct
SPEAKERS	A, B (4 to 16 ohms)/A + B (8 to 16 ohms)
POWER REQUIREMENTS	120V, 60 Hz for USA & Canada 240V, 50 Hz for Australia 110V/120V/220V/240V, 50/60 Hz switchable for other countries.
DIMENSIONS	440(W) \times 100(H) \times 320(D) mm (17.3 \times 3.9 \times 12.6 inches)
WEIGHT	10 kg (22.0 lbs)

* For improvement purposes, specifications and design are subject to change without notice.

II. DISMANTLING OF UNIT

In case of trouble, etc. necessitating dismantling, please dismantle in the order shown in the photographs. Reassemble in reverse order.

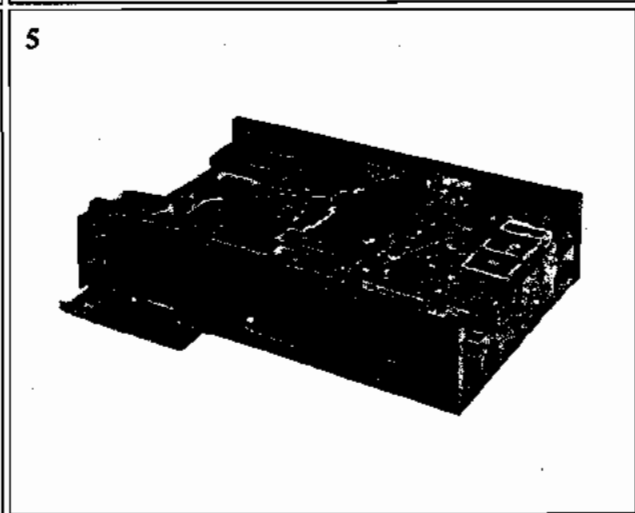
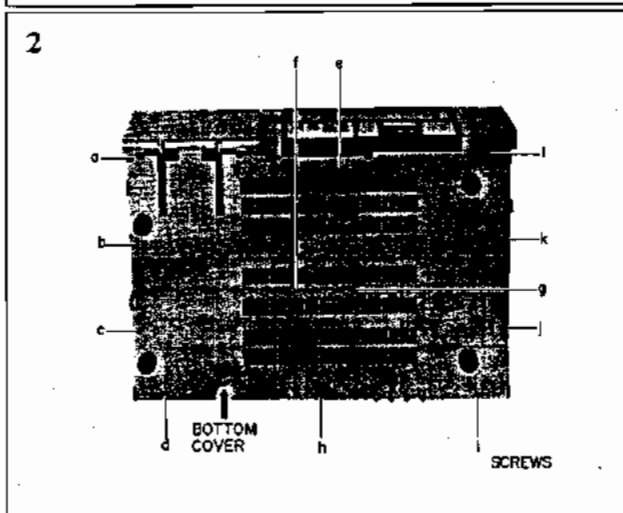
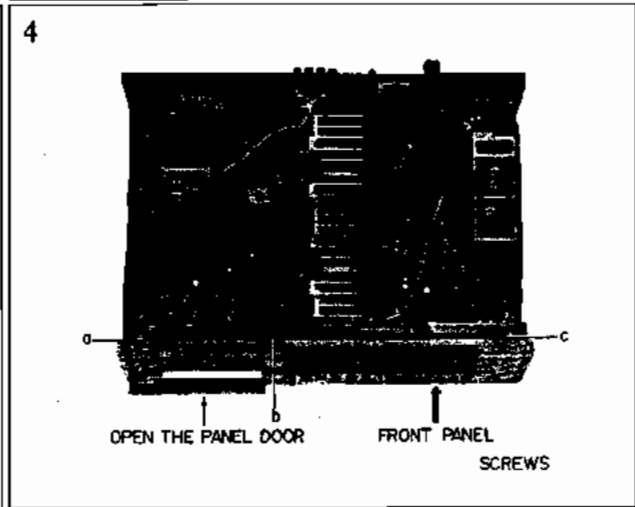
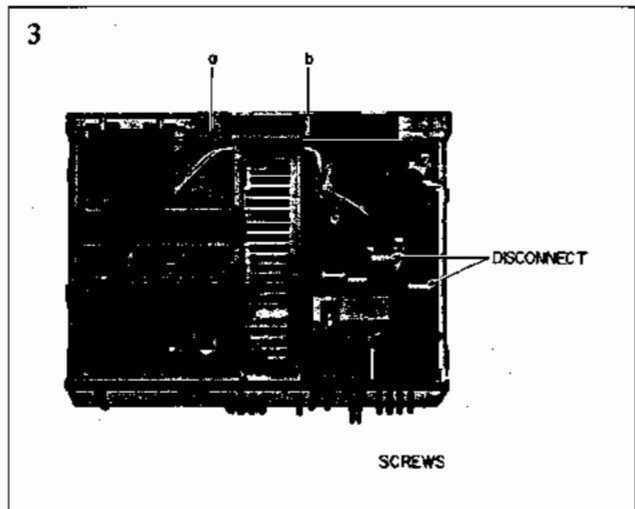
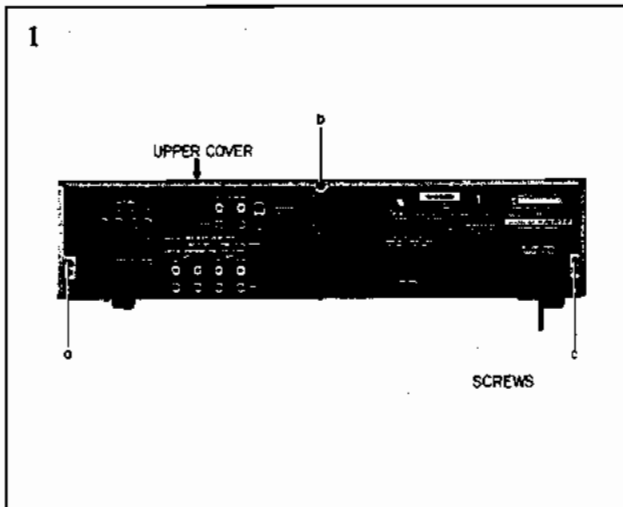

III. CONTROLS

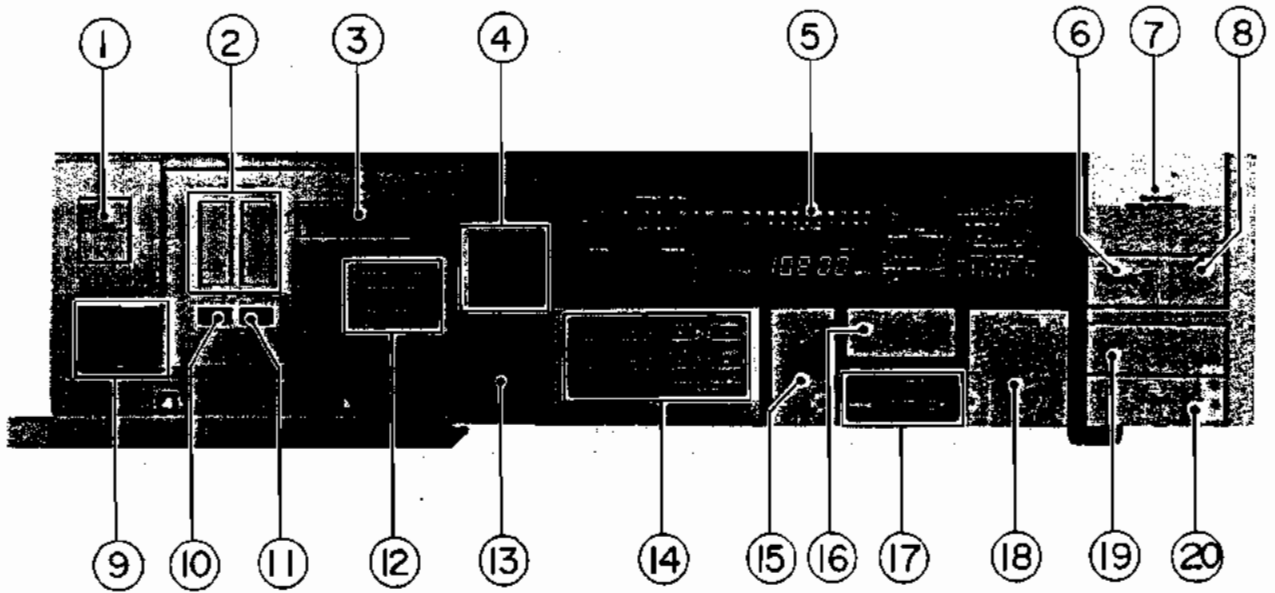

Model AA-R32/L

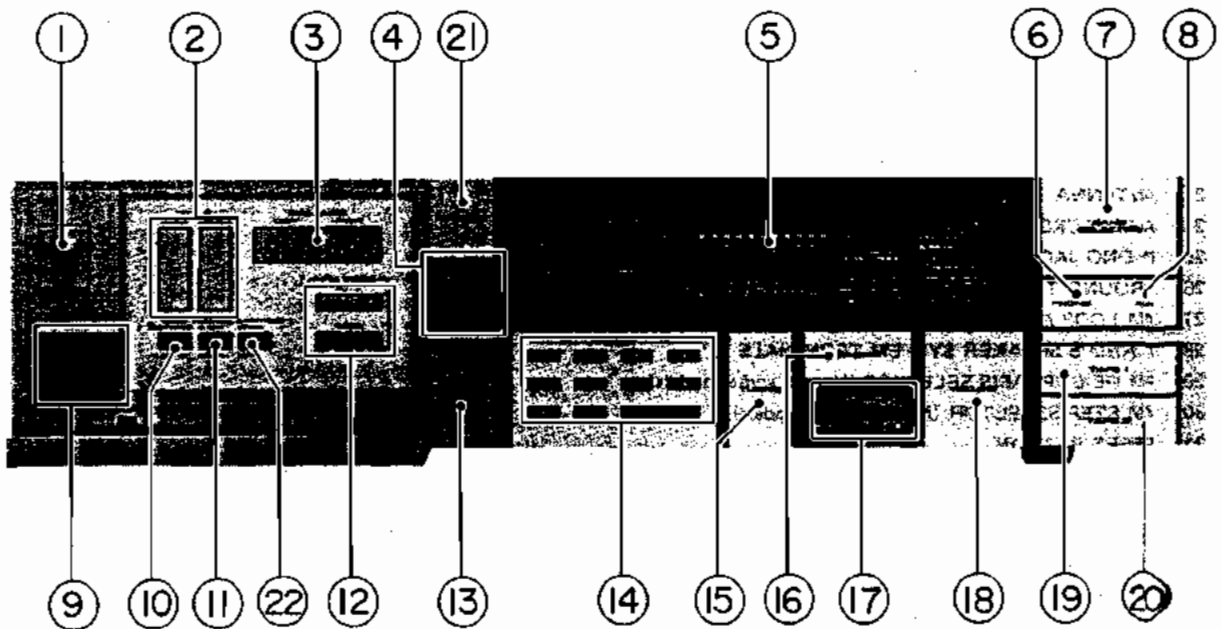

Model AA-R42

1. POWER SWITCH
2. BASS AND TREBLE CONTROL
3. BALANCE CONTROL
4. TUNING MODE SELECTOR
5. FL DISPLAY
6. PHONO BUTTON
7. BAND SELECTOR
8. AUX BUTTON
9. SPEAKER SELECTOR
10. MODE SELECTOR (STEREO/MONO)
11. SUBSONIC FILTER SWITCH

12. FM MODE SELECTOR
13. PHONES JACK
14. PRESET STATION BUTTON
15. TUNING (UP/DOWN) BUTTON
16. FADER BUTTON
17. ACOUSTIC MEMORIES AND DEFEAT BUTTONS
18. VOLUME (UP/DOWN) BUTTON
19. TAPE 1 BUTTON
20. TAPE 2 BUTTON
21. RANDOM BUTTON (AA-R42 Only)
22. CARTRIDGE SELECTOR (AA-R42 Only)

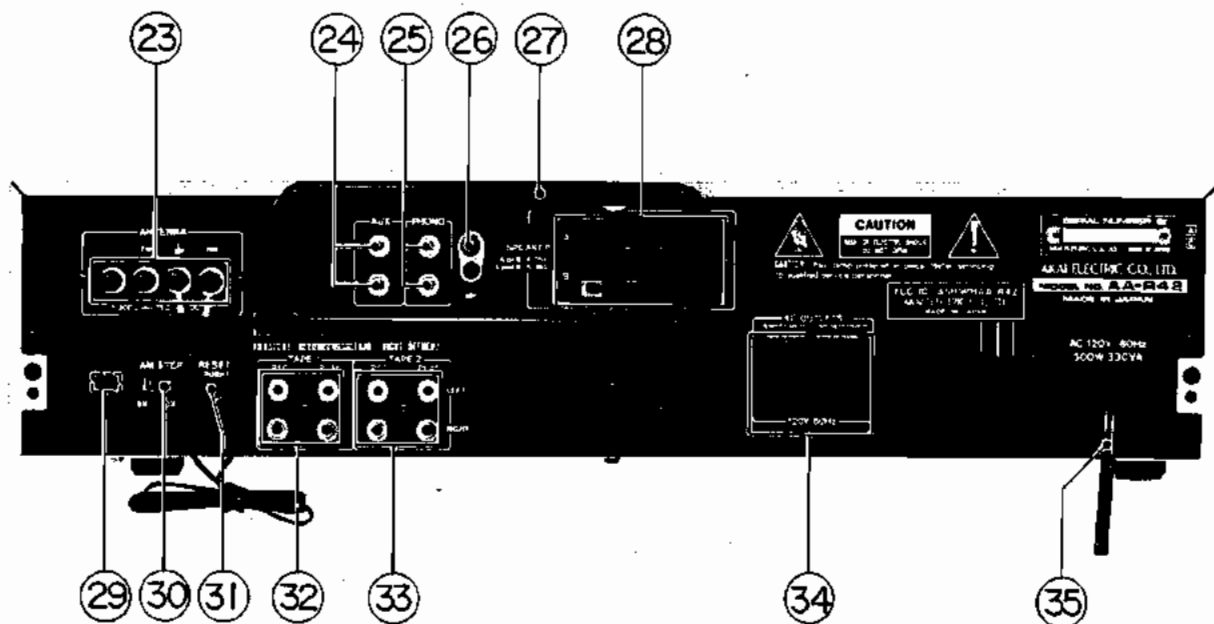

Model AA-R32/L, R42

Fig. 3-1 Controls

- 23. ANTENNA TERMINALS
- 24. AUX JACKS
- 25. PHONO JACKS
- 26. GROUND TERMINAL
- 27. AM LOOP ANTENNA
- 28. A AND B SPEAKER SYSTEM TERMINALS
- 29. FM DE-EMPHASIS SELECTOR (Not on some models)
- 30. AM STEP SELECTOR (Not on some models)
- 31. RESET BUTTON
- 32. TAPE 1 REC/PLAY JACKS
- 33. TAPE 2
- 34. AC OUTLETS (Not on some models)
- 35. POWER CORD

IV. PRINCIPAL PARTS LOCATION

1. MODEL AA-R32/L

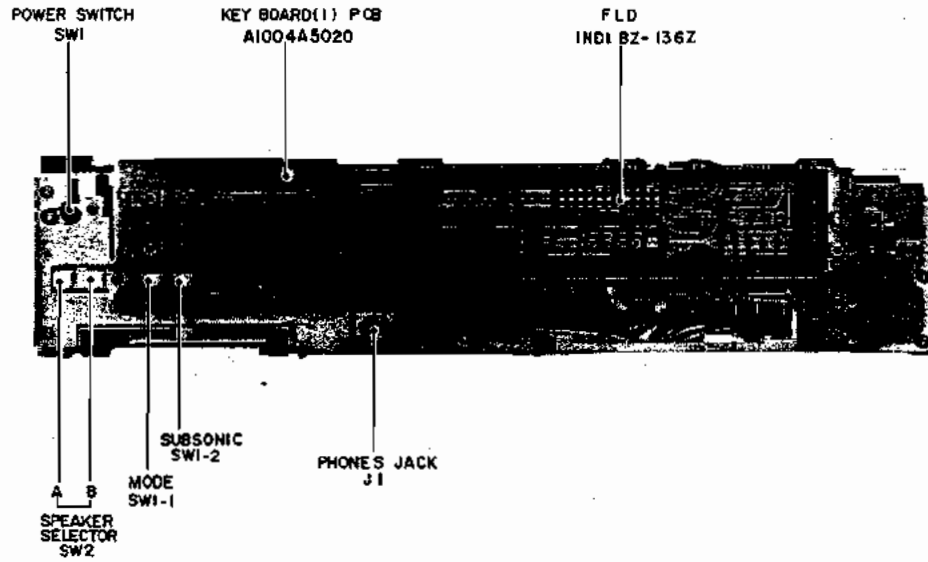

Fig. 3-2 Model AA-R32/L Front View

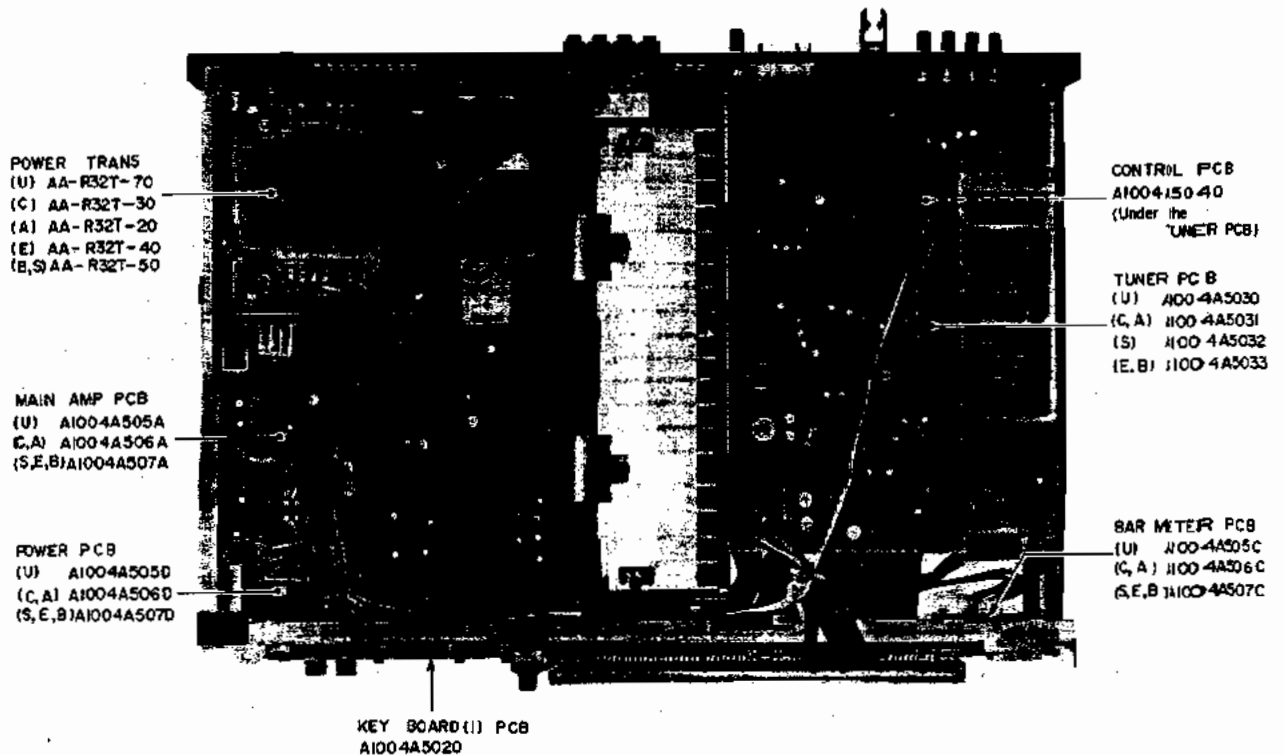

Fig. 3-3 Model AA-R32/L Top View

2. MODEL AA-R42

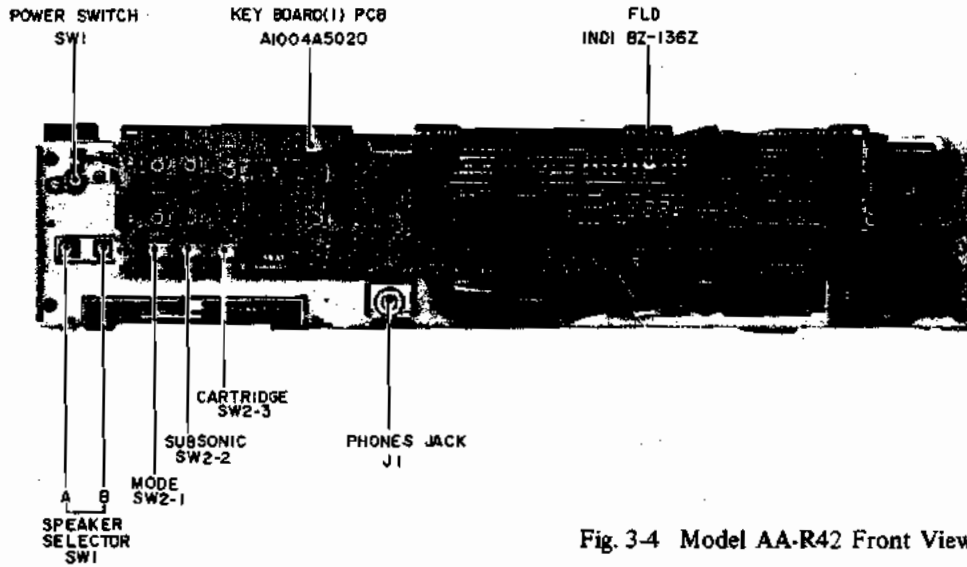

Fig. 3-4 Model AA-R42 Front View

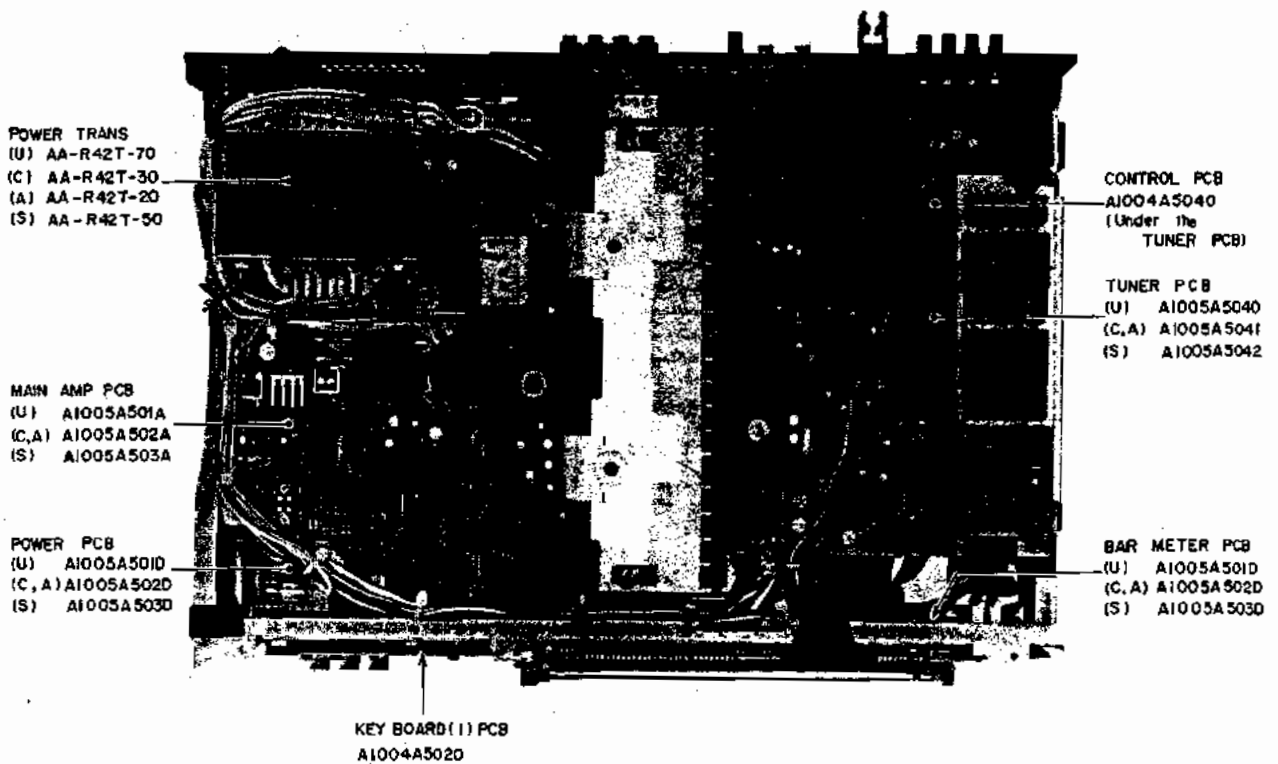

Fig. 3-5 Model AA-R42 Top View

V. CONVERSION

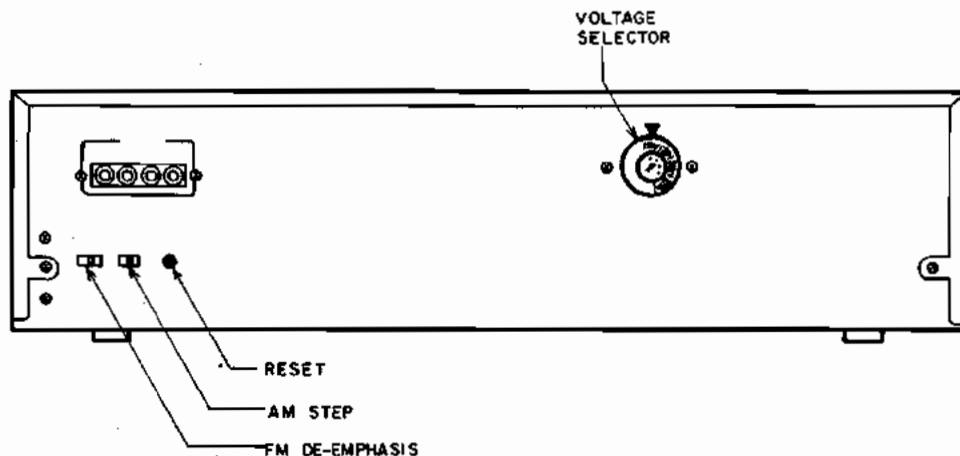

Fig. 3-6 Rear View

1. VOLTAGE CONVERSION

Models for Canada, USA and Australia are not equipped with this facility. Each machine is preset at the factory according to destination, but some machines can be set to 110V, 120V, 220V or 240V as required.

If your machine's voltage can be converted:

- 1) Disconnect the power cord from the power supply.
- 2) Turn the VOLTAGE SELECTOR located on the rear panel with a screwdriver until the correct voltage is indicated.

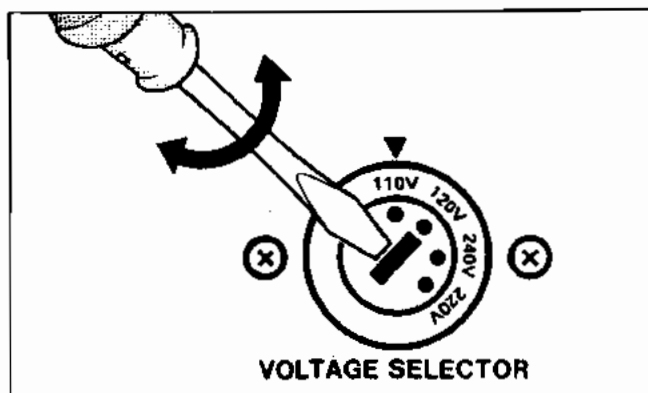

Fig. 3-7

2. FM DE-EMPHASIS SELECTOR (NOT ON SOME MODELS.)

Use this selector to de-emphasize an FM signal encoded with Dolby NR by an amount (50 μ s or 75 μ s) equal to the emphasis made at the broadcasting station.

Set this selector according to your area.

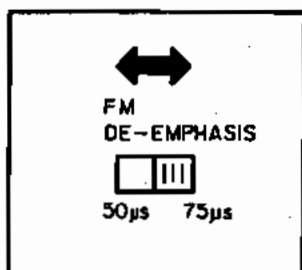

Fig. 3-8

3. AM STEP SELECTOR (NOT ON SOME MODELS.)

The Akai AA-R32/42 can scan the AM frequencies in steps of 9 kHz or 10 kHz. Set this selector according to the broadcasting frequencies in your area. After setting the AM STEP selector, turn on the Akai AA-R32/42 and then depress the RESET button.

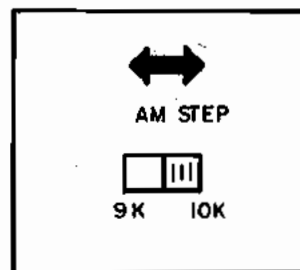

Fig. 3-9

VI. ADJUSTMENTS

1. CLOCK FREQUENCY ADJUSTMENT (Refer to Fig. 3-10)

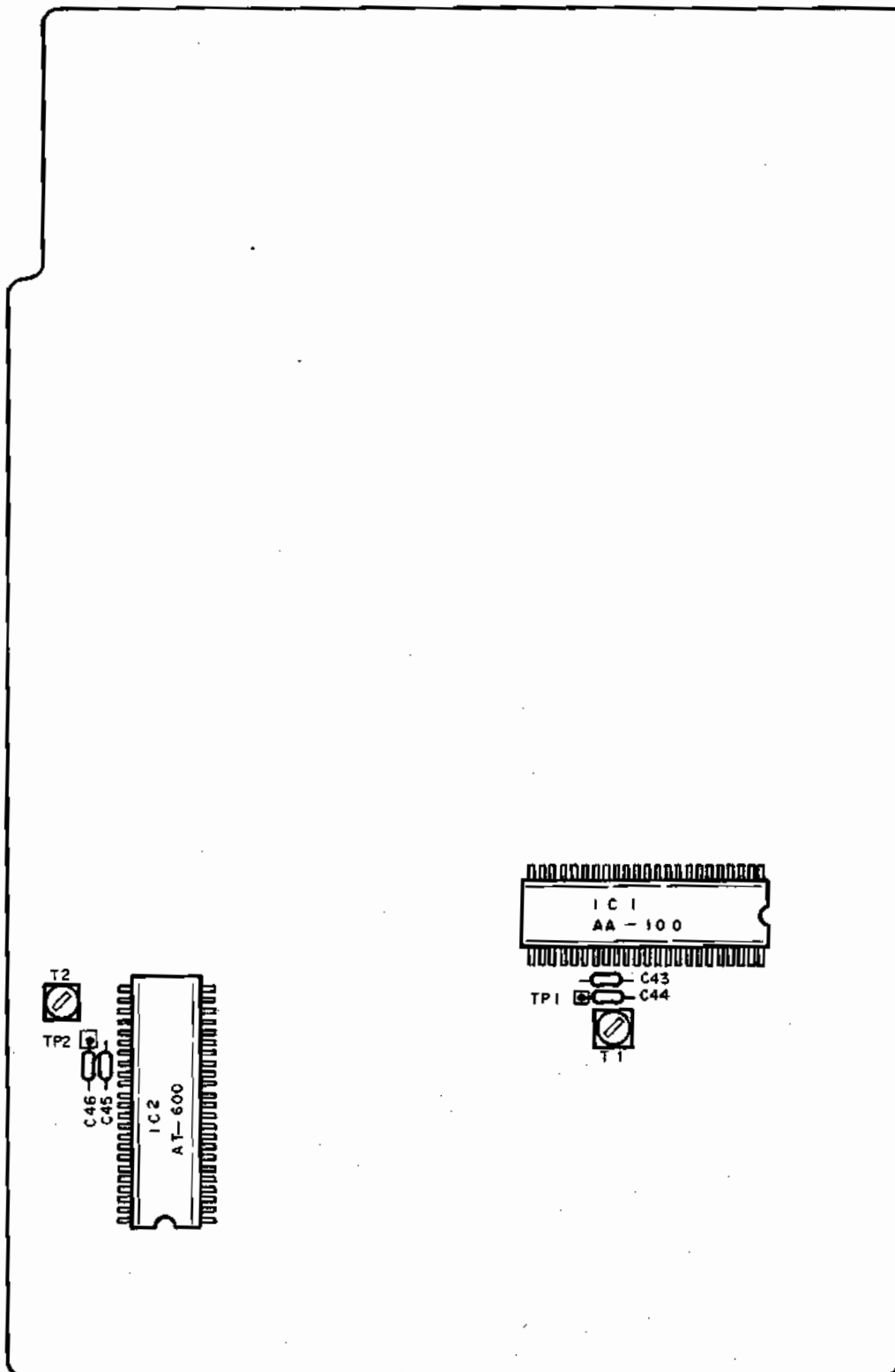

Fig. 3-10 AA-R32/L, AA-R42 Control PCB

- 1) Connect a Frequency Counter to TP1 (TP2).
- 2) Confirm that Frequency Counter reading is 400 kHz ~ 430 kHz.
- 3) Adjust T1 (Frequency of TP1) or T2 (Frequency of TP2), if adjustment is necessary.

2. MODEL AA-R32/L, AA-R42 TUNER ADJUSTMENT

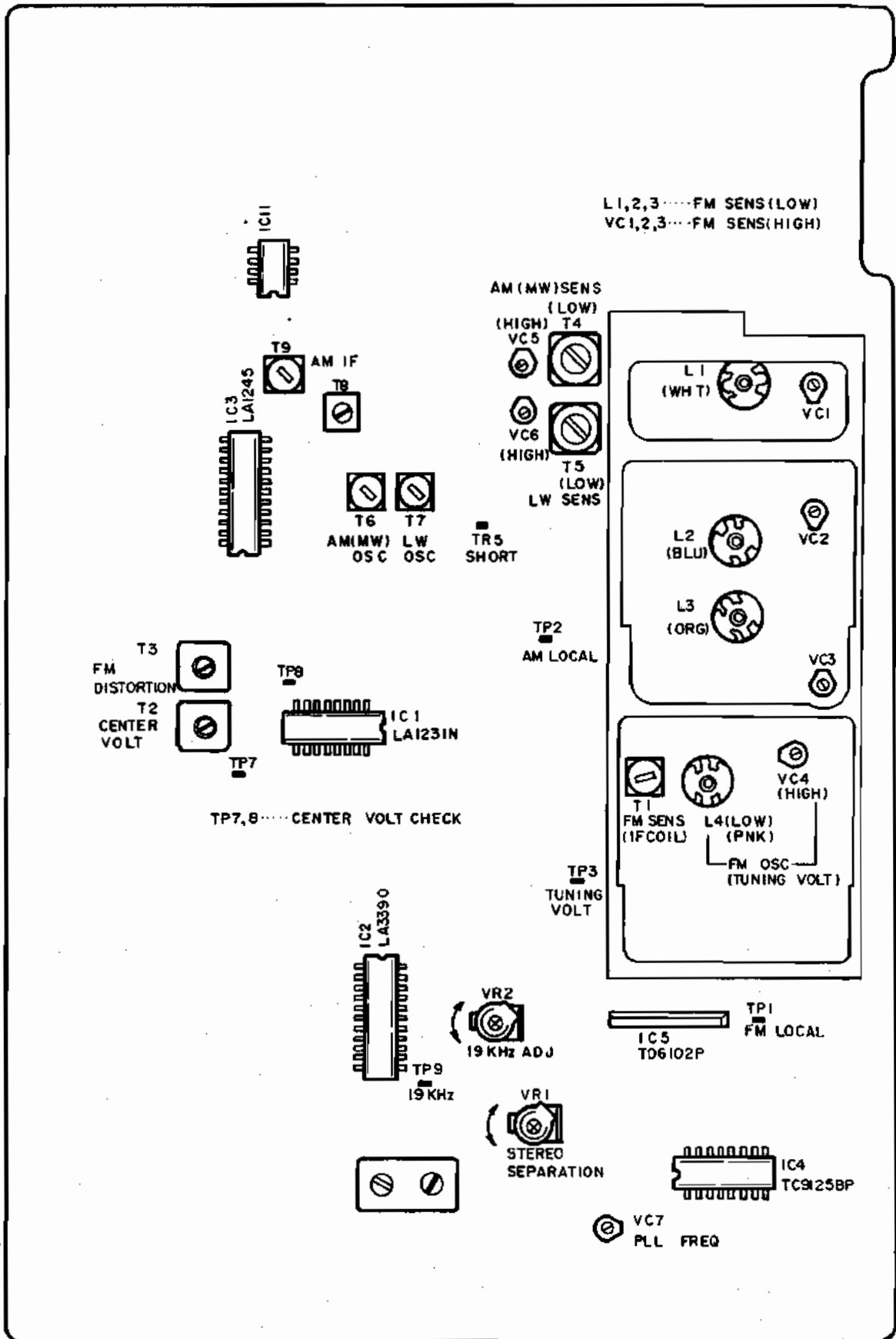

Fig. 3-11 Tuner PCB

1) AM (AA-R32L : MW) SECTION ADJUSTMENT (Refer to Figs. 3-11, 12)

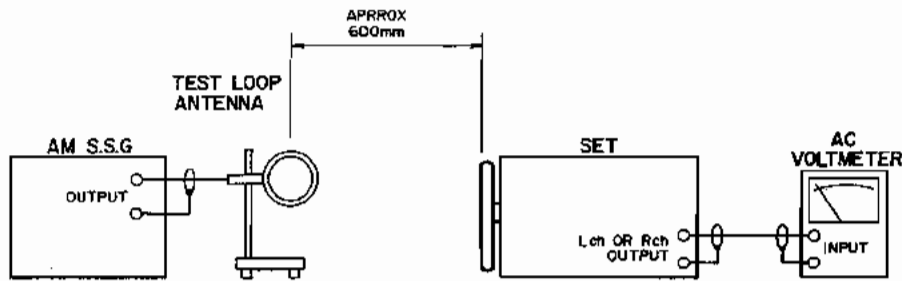

Fig. 3-12 · Instrument Connections for AM (MW, LW) Section Adjustment

Step	Adjustment Item	Adjustment Point	Result	Remarks
1	PLL Frequency	VC7	Digital Display Indicating Freq. +10.7 MHz	Band SW to FM Connect Frequency Counter between TP1 and GND. (See NOTE)
2	AM (MW) OSC	T6	700 ± 1 kHz (AA-R32/R42) 730 ± 1 kHz (AA-R32L)	Band SW to AM (MW). Connect TP5 to GND. Connect Frequency Counter between TP2 and GND.
3	AM IF	T8, 9	Max Output	1,000 kHz (1008 kHz), 50 dB 400 Hz (30%) input.
4	Low Range Sensitivity 600 kHz (603 kHz)	T4	Max Output Distortion Factor: Less than 10%	600 kHz (603 kHz), 50 dB, 400 Hz (30%) input.
5	High Range Sensitivity 1,400 kHz (1,404 kHz)	VC5	Max Output Distortion Factor: Less than 10%	1,400 kHz (1,404 kHz), 50 dB, 400 Hz (30%) input.
6				Readjust in Steps 4 and 5.

NOTE: Digital display frequency +10.7 MHz means that when the display frequency of Digital Display is 100 MHz, it should be adjusted to 110.7 MHz.

2) LW SECTION ADJUSTMENT (AA-R32L only) (Refer to Figs. 3-11, 12)

Step	Adjustment Item	Adjustment Point	Result	Remarks
1	LW OSC	T7	530 kHz ± 1 kHz	Band SW to LW. Connect TP5 to GND. Connect a Frequency Counter between TP2 and GND.
2	Low Range Sensitivity 155 kHz	T5	Max Output Distortion Factor: Less than 10%	155 kHz, 50 dB, 400 Hz (30%) input.
3	High Range Sensitivity 299 kHz	VC6	Max Output Distortion Factor: Less than 10%	299 kHz, 50 dB, 400 Hz (30%) input.
4				Readjust in Steps 2 and 3.

3) FM SECTION ADJUSTMENT (Refer to Figs. 3-11, 13)

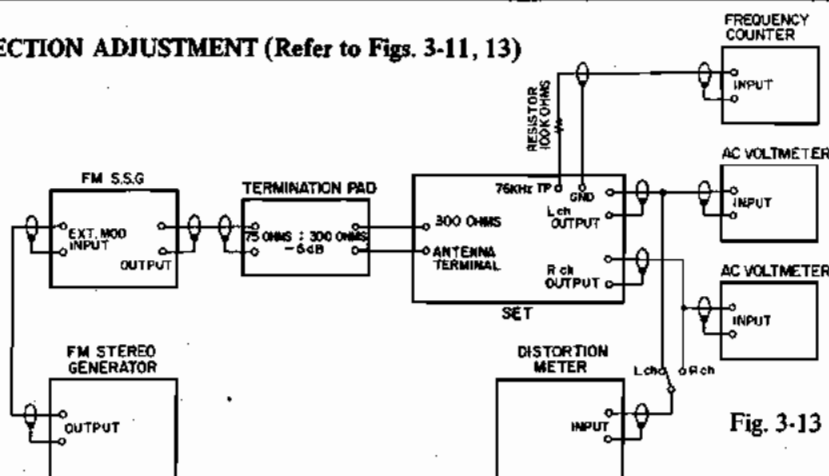

Fig. 3-13 Instruments Connection for FM Section Adjustment

Step	Adjustment Item	Adjustment Point	Result	Remarks
1	FM Tuning Voltage (LOW)	L4	3.2V	1) Band SW to FM 2) Display to 88 MHz. 3) Connect a digital Voltmeter between TP3 and GND.
2	FM Tuning Voltage (HIGH)	VC4	20V	Display to 108 MHz same as above.
3				Readjust in Steps 1 and 2.
4	PLL Frequency	VC7	Digital Display Indicating Frequency +10.7 MHz	Connect a Frequency counter between TP1 and GND. (See NOTE 1).
5	Low Range Sensitivity 88.0 MHz	L1, 2, 3 T1	Distortion Factor: Less than 3%	1) Mode SW to MONO. 2) 88 MHz less than 8 dB, 1 kHz (mono 100%) input.
6	High Range Sensitivity 108 MHz	VC1, 2, 3	Distortion Factor: Less than 3%	108 MHz, less than 8 dB, 1 kHz (mono 100%) input.
7				Readjust in Steps 5 and 6.
8	Center Voltage	T2	Center Tuning Meter Indication	1) Connect a Tuning Meter between TP7 and TP8. (See NOTE 2) 2) Tunes only noise without interference from broadcasting.
9	Distortion Factor	T3	Distortion Factor: Less than 0.3%	98 MHz, 60 dB, 1 kHz (mono, 100%) input.
10				Readjust in Steps 8 and 9.
11	MPX Free Running Frequency	VR2	19 kHz \pm 50 Hz	Mode SW to FM Auto Connect a Frequency Counter between TP3 and GND. 98 MHz non-modulation signal input.
12	Stereo Separation	VR1	More than 40 dB	98 MHz, 60 dB, 1 kHz (Stereo 100%) Lch (Rch) input. Minimum output of Rch (Lch)

NOTES: 1. Digital display frequency +10.7 MHz means that when the display frequency of Digital Display is 100 MHz, it should be adjusted to 110.7 MHz.
2. For the Center Meter should be used the tuning meter and the like available as a part of the other models.

3. MODEL AA-R32/L, AA-R42 POWER LEVEL METER SENSITIVITY ADJUSTMENT

(Refer to Figs. 3-14, 15)

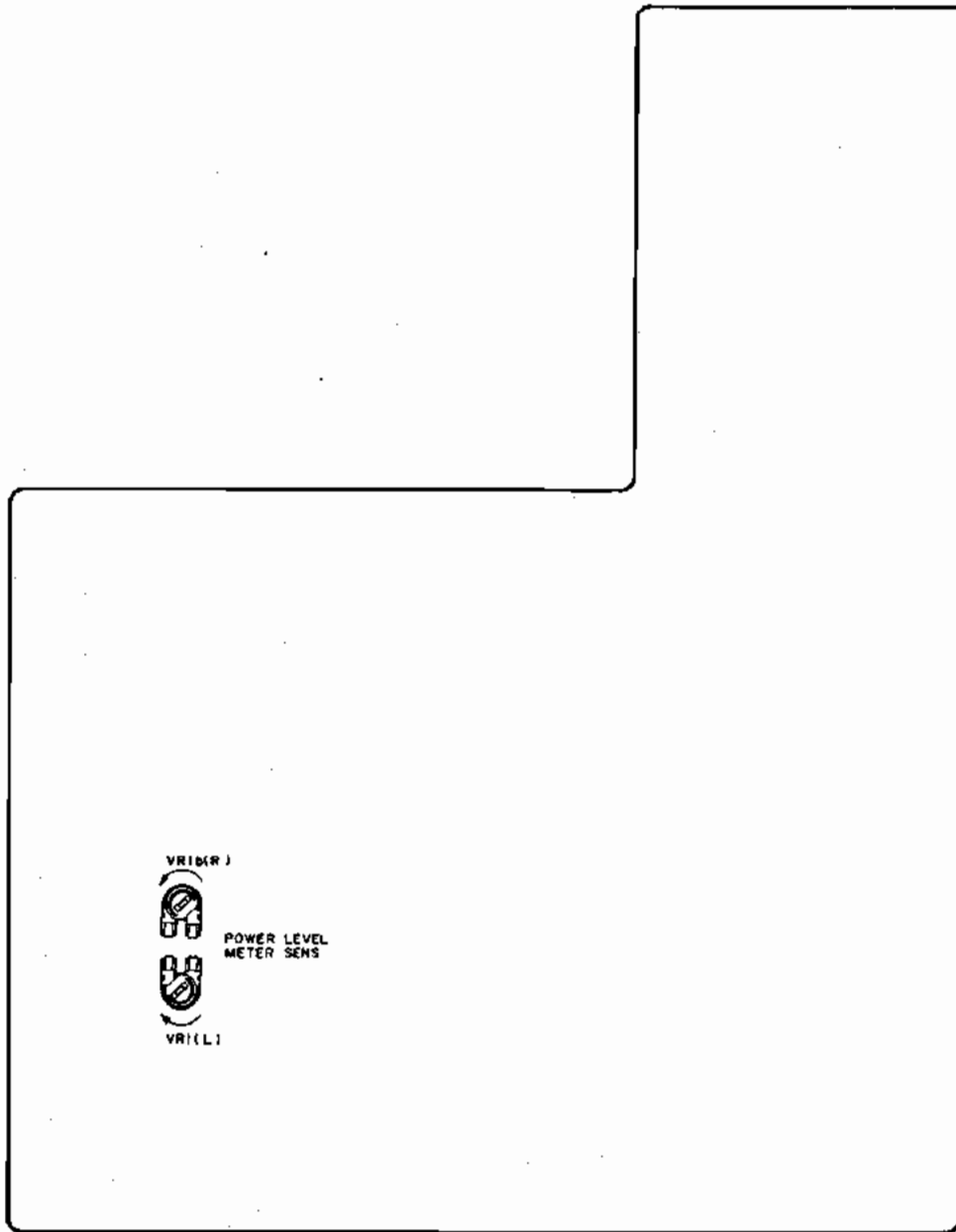

Fig. 3-14 Main Amp PCB

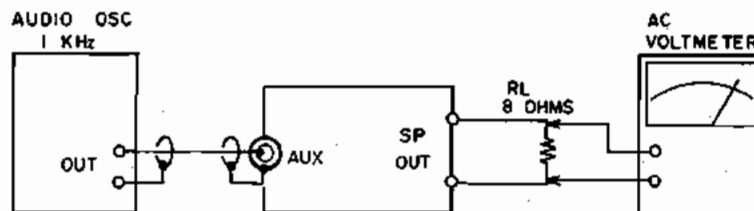

Fig. 3-15 Instrument Connection for Power Level Meter Sensitivity

Connect the RL (8 ohms) resistors to Speaker Out. Then apply a 1 kHz signal to the AUX input terminals, adjusting the input level so as to obtain the rated output

voltage level (15.5V) at Speaker Out. Adjust VR1 (5 k Ω) on the Main Amp P.C Board so that the 30 Watts Segment in the Power Level Meter lights up.

VII. CLASSIFICATION OF VARIOUS P.C BOARDS

1. MODEL AA-R32/L P.C BOARD TITLES AND IDENTIFICATION NUMBERS

1) MODEL AA-R32

P.C Board Title	P.C Board Number	Notes
Tuner P.C Board	A1004A5030	U
Tuner P.C Board	A1004A5031	C, A
Tuner P.C Board	A1004A5032	S
Control P.C Board	A1004A5040	
KEY Board (1) P.C Board	A1004A5020	
KEY Board (2) P.C Board	A1004B5010	
Main Amp P.C Board	A1004A505A	U
Main Amp P.C Board	A1004A506A	C, A
Main Amp P.C Board	A1004A507A	S
Head Phone P.C Board	A1004A505B	U
Head Phone P.C Board	A1004A506B	C, A
Head Phone P.C Board	A1004A507B	S
Bar Meter P.C Board	A1004A505C	U
Bar Meter P.C Board	A1004A506C	C, A
Bar Meter P.C Board	A1004A507C	S
Power P.C Board	A1004A505D	U
Power P.C Board	A1004A506D	C, A
Power P.C Board	A1004A507D	S

2) MODEL AA-R32L

P.C Board Title	P.C Board Number	Notes
Tuner P.C Board	A1004A5033	
Control P.C Board	A1004A5040	
KEY Board (1)	A1004A5020	
KEY Board (2)	A1004B5010	
Main Amp P.C Board	A1004A507A	
Headphone P.C Board	A1004A507B	
Bar Meter P.C Board	A1004A507C	
Power P.C Board	A1004A507D	

2. MODEL AA-R42 P.C BOARD TITLES AND IDENTIFICATION NUMBERS

P.C Board Title	P.C Board Number	Notes
Tuner P.C Board	A1005A5040	U
Tuner P.C Board	A1005A5041	C, A
Tuner P.C Board	A1005A5042	S
Control P.C Board	A1004A5040	
KEY Board (1) P.C Board	A1004A5020	
KEY Board (2) P.C Board	A1004B5010	
Main Amp P.C Board	A1005A501A	U
Main Amp P.C Board	A1005A502A	C, A
Main Amp P.C Board	A1005A503A	S
Head Phone P.C Board	A1005A501B	U
Head Phone P.C Board	A1005A502B	C, A
Head Phone P.C Board	A1005A503B	S
Bar Meter P.C Board	A1005A501C	U
Bar Meter P.C Board	A1005A502C	C, A
Bar Meter P.C Board	A1005A503C	S
Power P.C Board	A1005A501D	U
Power P.C Board	A1005A502D	C, A
Power P.C Board	A1005A503D	S

3. MODEL AA-R32/L COMPOSITION OF VARIOUS P.C BOARDS

1) MODEL AA-R32 TUNER P.C BOARD A1004A5030, 31, 32 (3ED)

TR1 3SK73(Y)
 TR2 2SC2999(C,D)
 TR3 2SK212(D,E)
 TR4 2SC930(E,F)
 TR5 2SC3000(E,F)
 TR6 to 9, 10, 18, 24 to 26
 2SC536K-NP(E,F,G)
 TR9, 23 2SA608K-NP(E,F,G)
 TR21 2SD571(L,M)
 TR22 2SD313HP(E,F)
 TR27 2SK223(E,F)

LOCATION OF COMPONENTS
 IC1 C2 TR8 E2
 IC2 D2 TR9,10 D2
 IC3 B1 TR18 C1
 IC4 E3 TR21 E1
 IC5 D3 TR22 to 25 D1
 IC11 A1 TR26, 27 D3

TR TERMINAL
 TR1 B3 ① to ⑤ E1
 TR2 C3 ⑥, ⑦ A3
 TR3, 4 D2 J3 D1
 TR5 C2 J6 D1
 TR6, 7 C1 J10 E3
 J14 A3

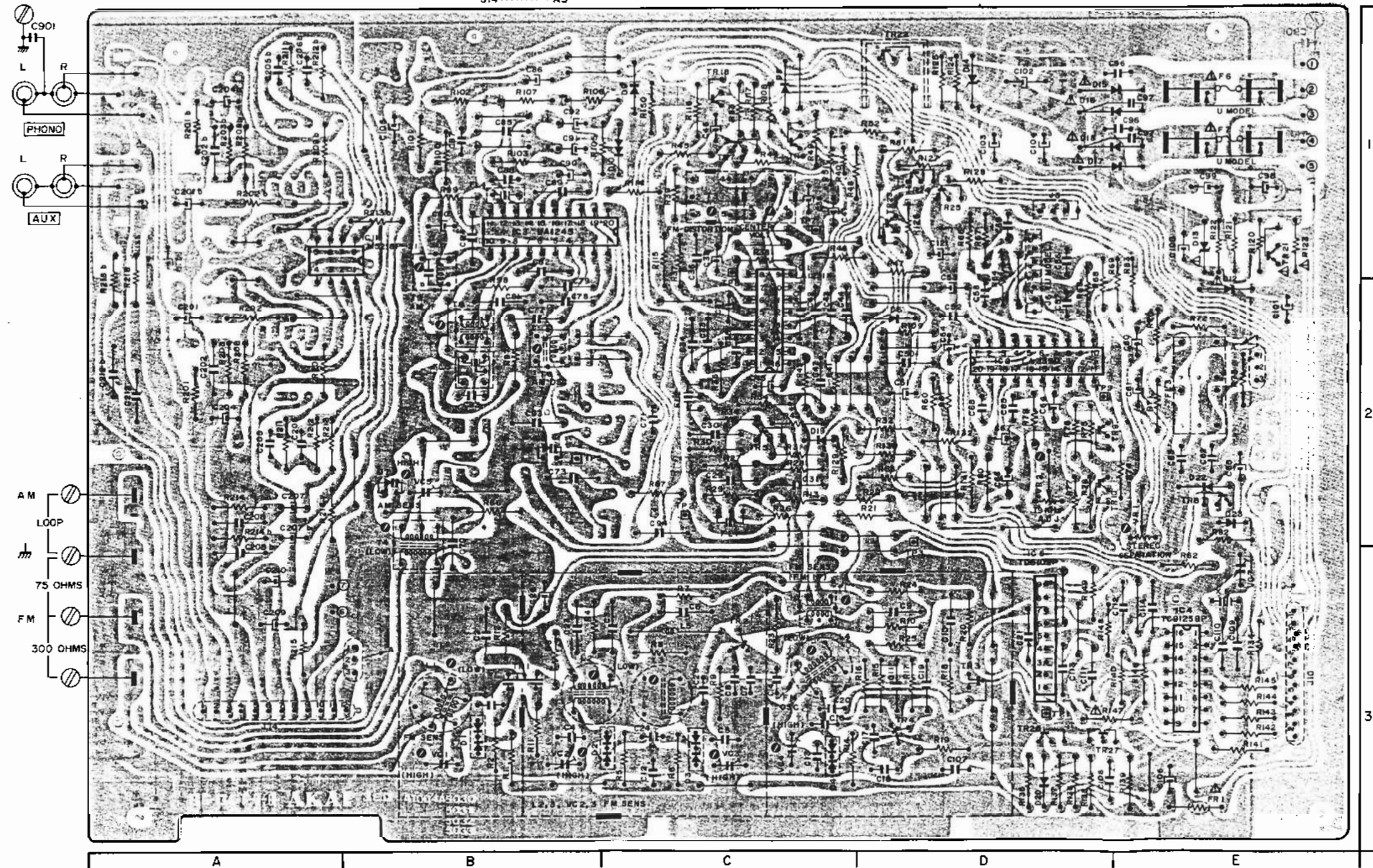

TUNER PCB(U) A1004A5030
 (A,C) A1004A5031
 (S) A1004A5032

WARNING: Δ INDICATES SAFETY CRITICAL COMPONENTS FOR CONTINUED SAFETY. REPLACE SAFETY CRITICAL COMPONENTS ONLY WITH MANUFACTURER'S RECOMMENDED PARTS.
 AVERTISSEMENT: Δ IL INDIQUE LES COMPOSANTS CRITIQUES DE SÉCURITÉ. POUR MAINTENIR LE DEGRÉ DE SÉCURITÉ DE L'APPAREIL, NE REMPLACER QUE DES PIÈCES RECOMMANDÉES PAR LE FABRICANT.

2) MODEL AA-R32L TUNER P.C BOARD A1004A5033 (3ED)

LOCATION OF COMPONENTS

IC

- IC1.....C2
- IC2.....D2
- IC3.....B1
- IC4.....E3
- IC5.....D3
- IC11.....A1

TR

- TR1.....B3
- TR2.....C3
- TR3,4.....D2
- TR5.....C2
- TR6,7.....C1
- TR8.....E2
- TR9,10.....D2
- TR11to14.....B2
- TR15,16.....C2
- TR17.....B2
- TR18.....C1
- TR19,20.....E2
- TR21.....E1
- TR22to25.....D1
- TR26,27.....D3
- TR28.....B2

TERMINAL

- ① to ⑤...E1
- ⑥ ⑦...A3
- J3.....D1
- J10.....E3
- J14.....A3

- TR1.....3SK73(Y)
- TR2.....2SC2999(C, D)
- TR3.....2SK212(D, E)
- TR4.....2SC930(E, F)
- TR5.....2SC3000(E, F)
- TR6 to 8, 10, 16, 18 to 20, 24 to 26, 28
.....2SC536K-NP(E, F, G)
- TR9, 12 to 15, 23
.....2SK608K-NP(E, F, G)
- TR11.....2SC2878(A, B)
- TR17.....2SK19(I, Y)
- TR21.....2SD571(L, M)
- TR22.....2SD33HP(E, F)
- TR27.....2SK223(E, F)



2SK19



3SK73



2SK212



2SK223



2SC2999



2SA608K-NP
2SC536K-NP
2SC930
2SC2878
2SC3000



2SD571



2SD33HP

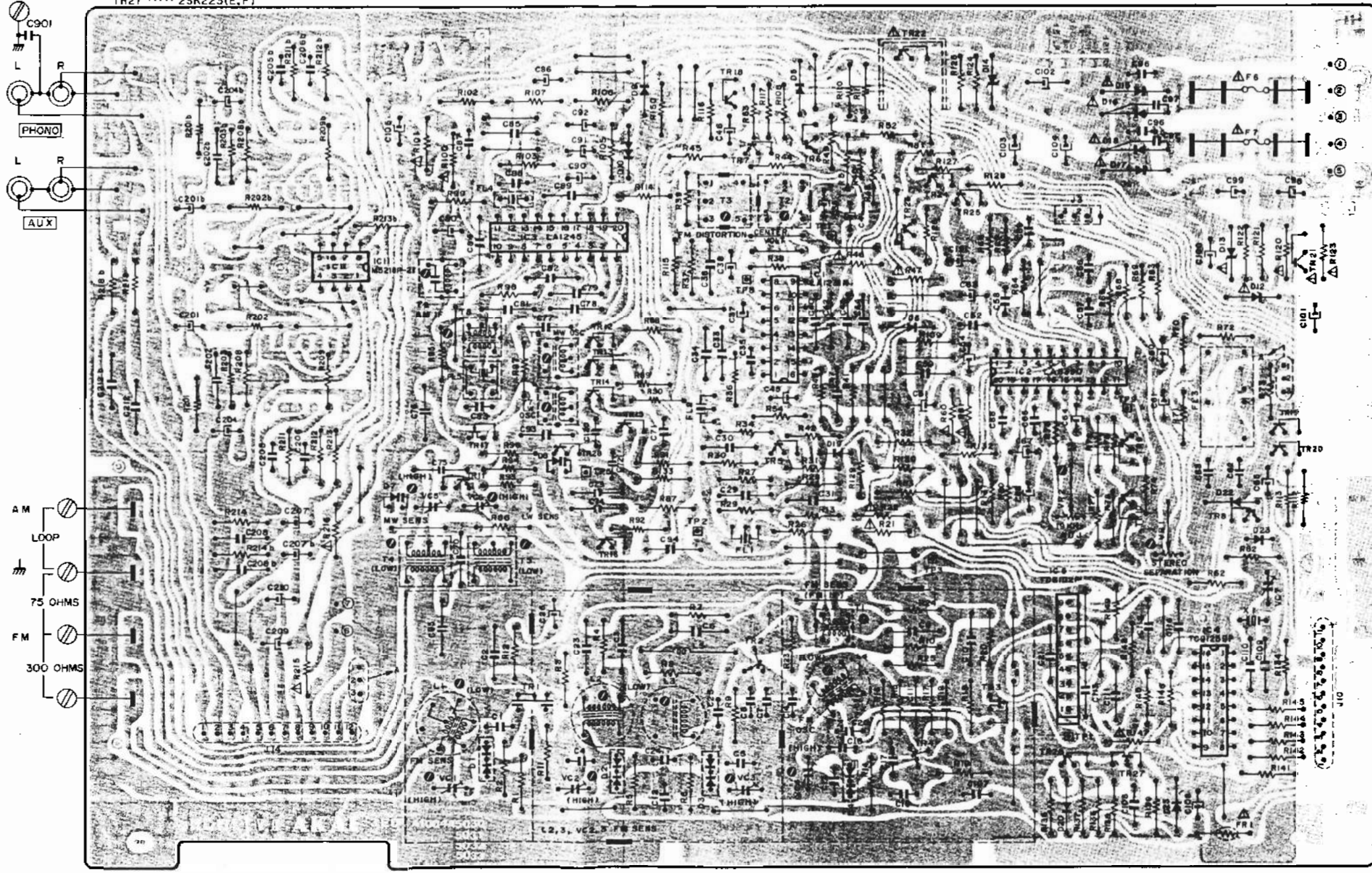

WARNING: ⚠ INDICATES SAFETY CRITICAL COMPONENTS. FOR CONTINUED SAFETY, REPLACE SAFETY CRITICAL COMPONENTS ONLY WITH MANUFACTURER'S RECOMMENDED PARTS.

AVERTISSEMENT: ⚠ IL INDIQUE LES COMPOSANTS CRITIQUES DE SÉCURITÉ. POUR MAINTENIR LE DEGRÉ DE SÉCURITÉ DE L'APPAREIL, NE REMPLACER QUE DES PIÈCES RECOMMANDÉES PAR LE FABRICANT.

TUNER PCB A1004A5033

3) MODEL AA-R32/L CONTROL P.C BOARD A1004A5040(3ED)

LOCATION OF COMPONENTS

IC	TR	J1
IC1---D3	TR1---D3	J1---B3
IC2---D,E	TR2---B1	J2---E2
IC3---C3		J3,4---E3
IC4---C2		J5---D1
IC5---E2		J6---D2
IC6---E3	TERMINAL	J7---C3
IC7---E2	①,②---C2	J8---C2
IC8---E1	③---D2	J9---C1
IC9---C1	④,⑤,⑥---E3	J10---E1
IC10---E3	⑦ to ⑪---A1	J11---D2
IC11---B3		J12---E2
IC12,13---B2		J13---D2
IC14---B3		J14---A2
IC15---A2		
IC16,17---A3		

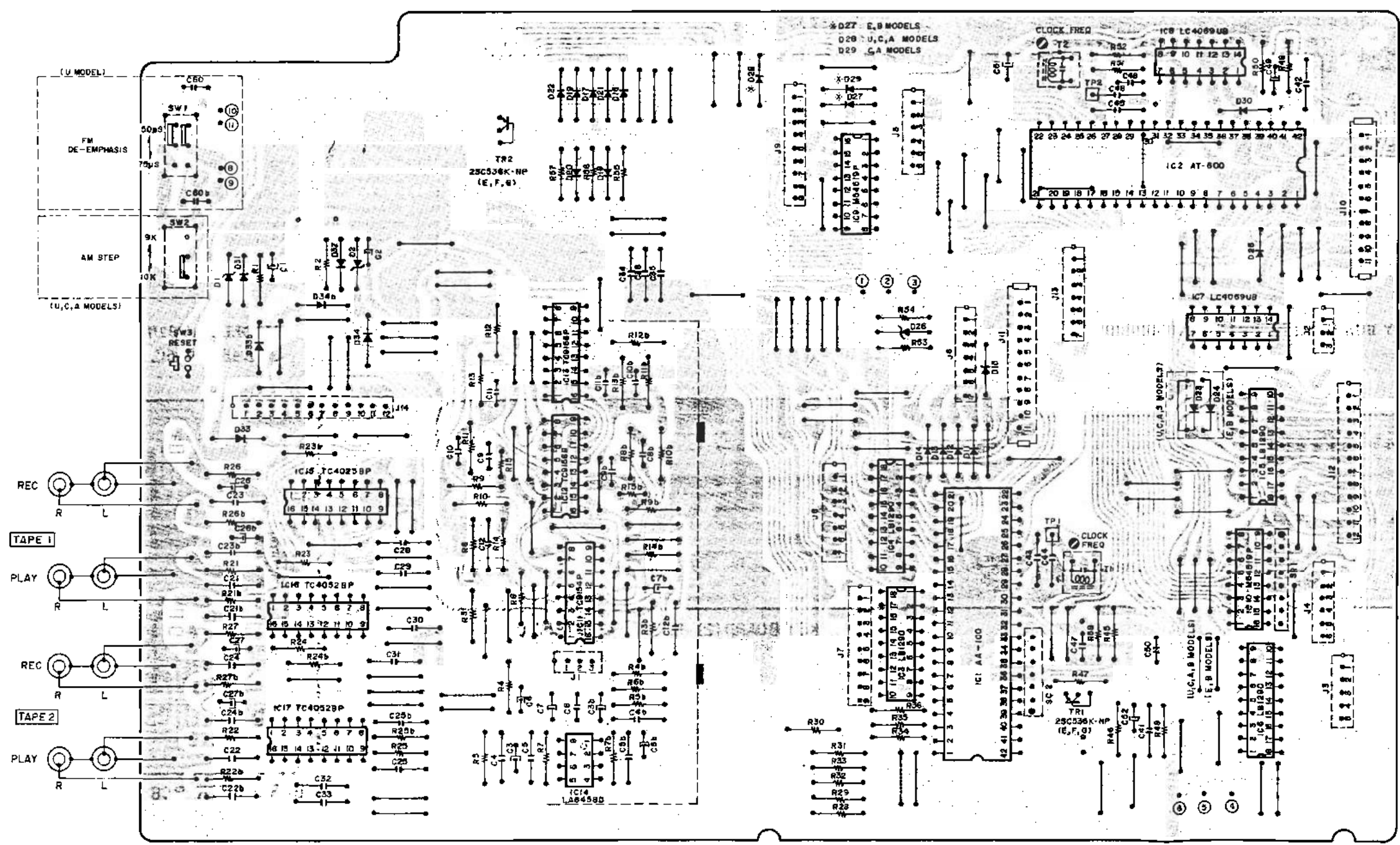
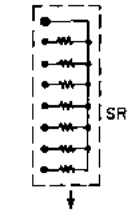
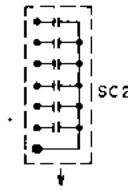

CONTROL PCB A1004A5040

4) MODEL AA-R32/L KEY BOARD (1) P.C BOARD A1004A5020

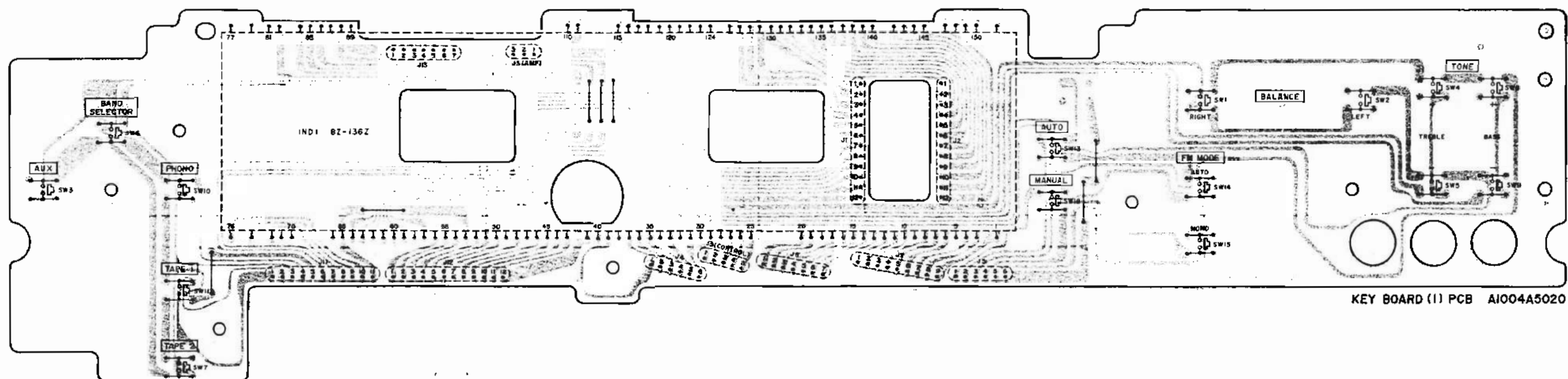

5) MODEL AA-R32/L KEY BOARD (2) P.C BOARD A1004B5010

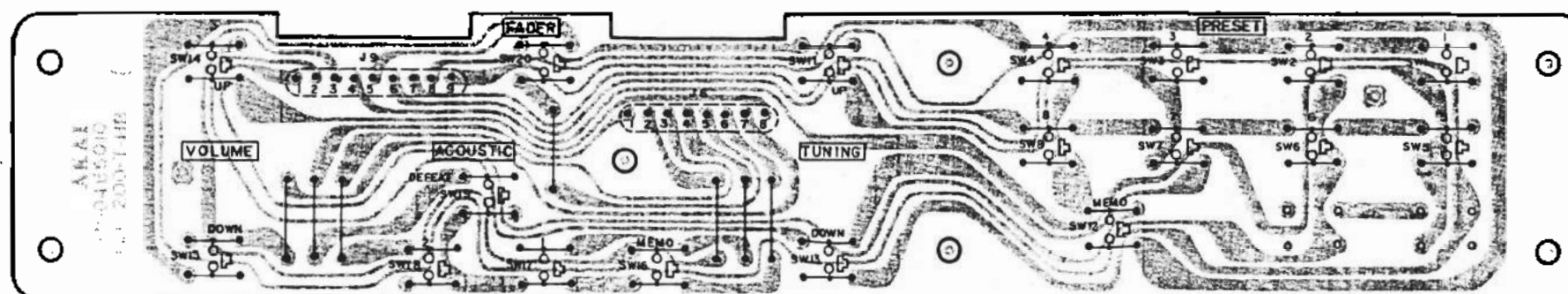

6) MODEL AA-R32/L BAR METER P.C BOARD A1004B505C, 6C, 7C

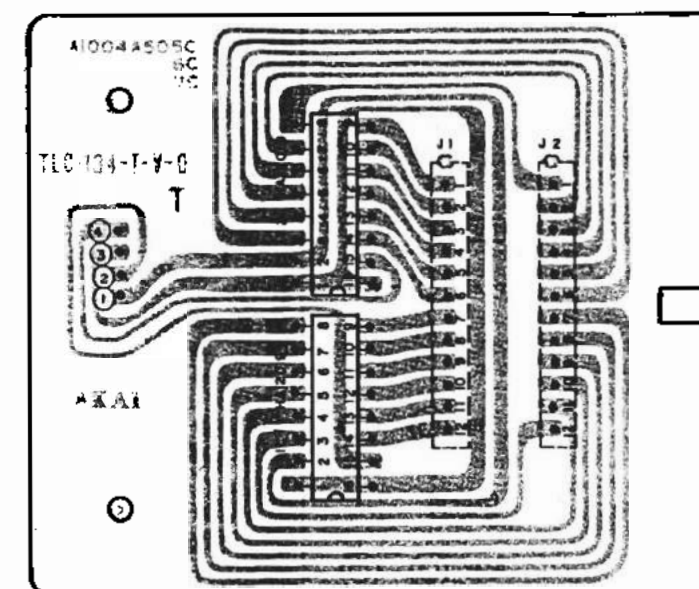

BAR METER PCB (U) A1004A505C
(C, A) A1004A506C
(E, B, S) A1004A507C

7) MODEL AA-R32/L MAIN AMP P.C BOARD A1004A505A, 6A, 7A(3ED)and HEADPHONE P.C BOARD A1004A505B, 6B, 7B

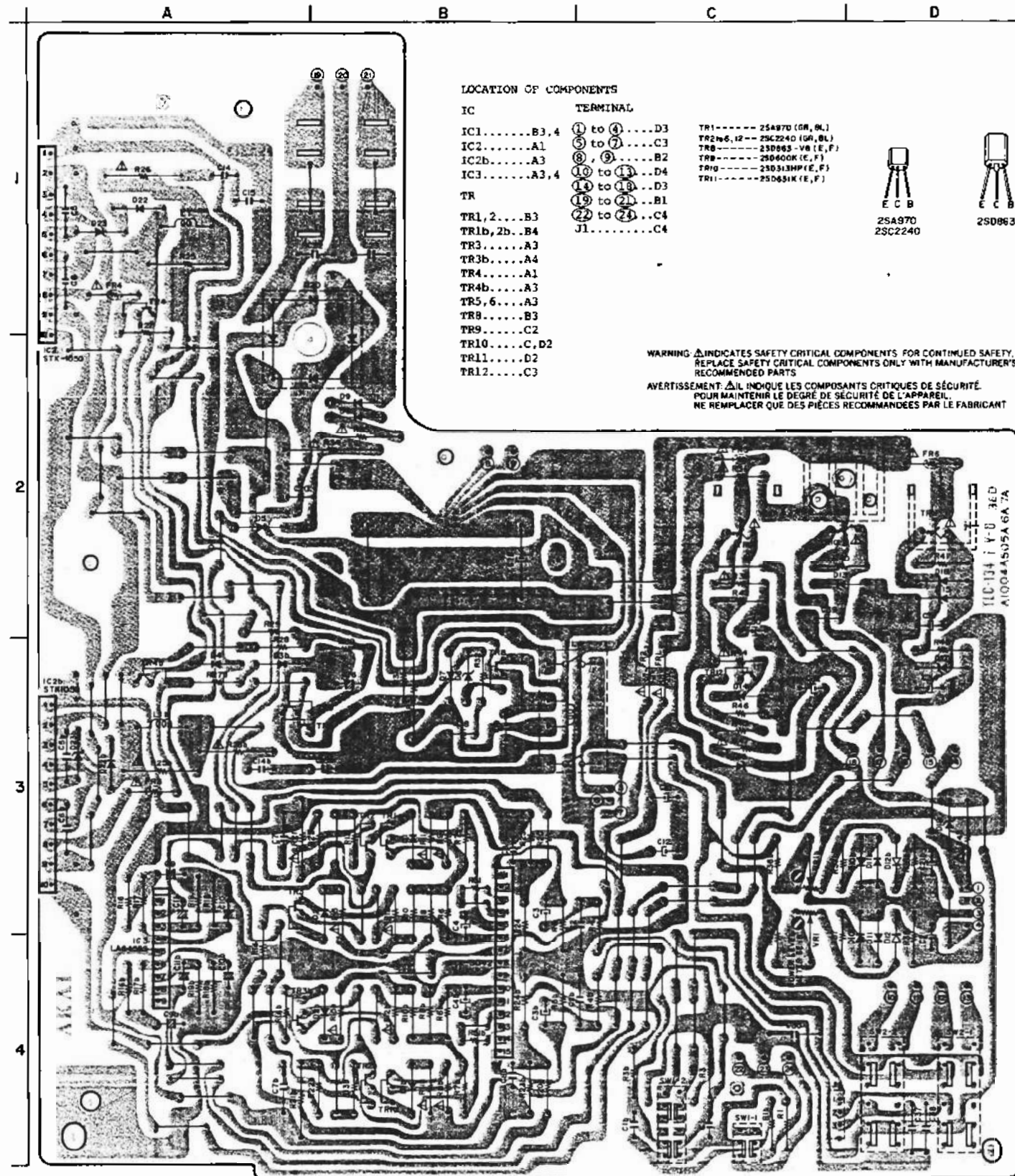

LOCATION OF COMPONENTS

IC	TERMINAL
IC1.....B3,4	① to ④.....D3
IC2.....A1	⑤ to ⑦.....C3
IC2b.....A3	⑧, ⑨.....B2
IC3.....A3,4	⑩ to ⑬.....D4
	⑭ to ⑯.....D3
TR	⑰ to ⑲.....B1
TR1, 2.....B3	⑳ to ㉑.....C4
TR1b, 2b.....B4	J1.....C4
TR3.....A3	
TR3b.....A4	
TR4.....A1	
TR4b.....A3	
TR5, 6.....A3	
TR8.....B3	
TR9.....C2	
TR10.....C,D2	
TR11.....D2	
TR12.....C3	

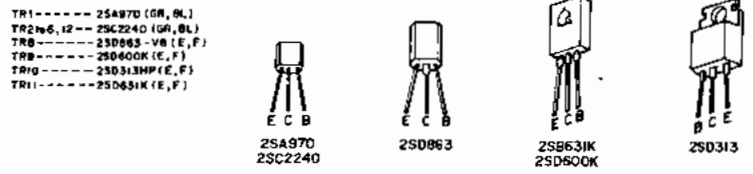

WARNING: Δ INDICATES SAFETY CRITICAL COMPONENTS. FOR CONTINUED SAFETY, REPLACE SAFETY CRITICAL COMPONENTS ONLY WITH MANUFACTURER'S RECOMMENDED PARTS.
 AVERTISSEMENT: Δ IL INDIQUE LES COMPOSANTS CRITIQUES DE SÉCURITÉ. POUR MAINTENIR LE DEGRÉ DE SÉCURITÉ DE L'APPAREIL, NE REMPLACER QUE DES PIÈCES RECOMMANDÉES PAR LE FABRICANT.

MAIN AMP PCB (U) A1004A505A
 (C,A) A1004A506A
 (E,B,S) A1004A507A

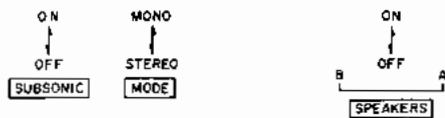

HEAD PHONE PCB
 (U) A1004A505B
 (C,A) A1004A506B
 (E,B,S) A1004A507B

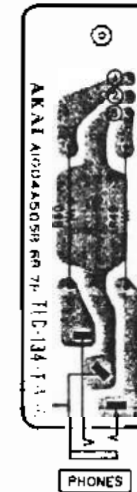

8) MODEL AA-R32 POWER P.C BOARD (U) A1004A505D

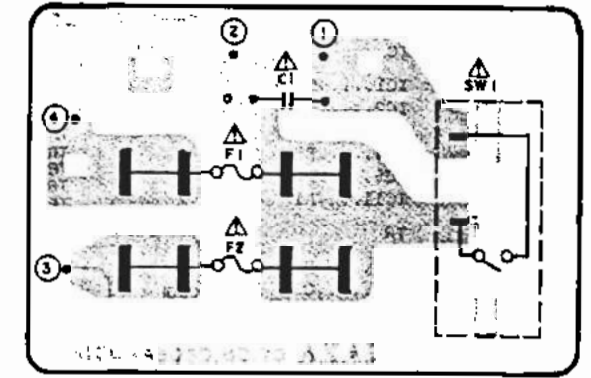

POWER PCB (U)
 A1004A505D

9) MODEL AA-R32 POWER P.C BOARD (C, A) 1004A506D

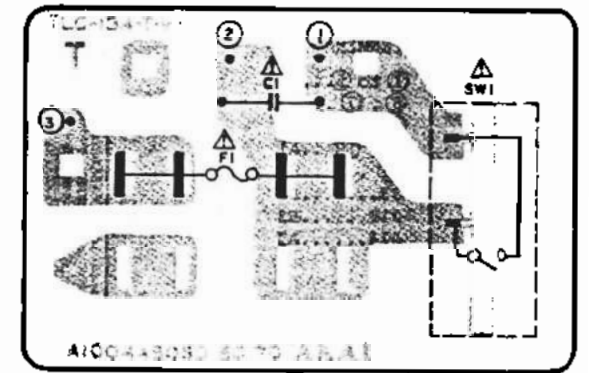

POWER PCB (C, A)
 A1004A506D

10) MODEL AA-R32/L POWER P.C BOARD (E, B, S) 1004A507D

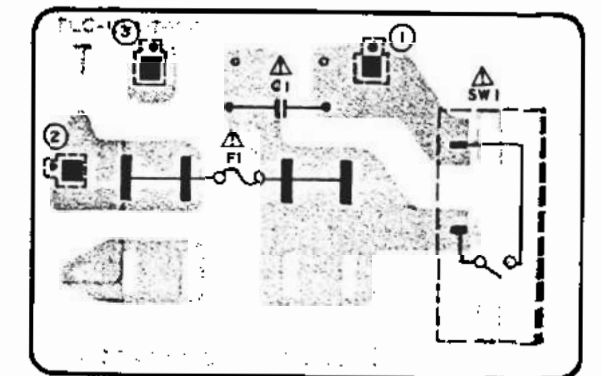

POWER PCB (E, B, S)
 A1004A507D

4. MODEL AA-R42 COMPOSITION OF VARIOUS P.C BOARD

1) TUNER P.C BOARD A1005A5040, 41, 42 (3ED)

LOCATION OF COMPONENTS

IC

IC1.....C2
 IC2.....D2
 IC3.....B1
 IC4.....E3
 IC5.....D3
 IC11.....A1

TR

TR1.....B3
 TR2.....C3
 TR3,4...D2
 TR5.....C2
 TR6,7...C1
 TR8.....E2
 TR9,10...D2
 TR11to14...B2
 TR15,16...C2
 TR17.....B2
 TR18.....C1
 TR19,20...E2
 TR21.....E1
 TR22to25...D1
 TR16,17...D3
 TR28.....B2
 TR35.....A2
 TR35b.....A1

TERMINAL

① to ⑤...E1
 ⑥, ⑦...A3
 ⑧.....A2
 ⑨, ⑩...A1
 ⑪.....B1
 J3.....D1
 J10.....E3
 J14.....A3

TR1.....35K73(Y)
 TR2.....25C2999(C,D)
 TR3.....25K212(D,E)
 TR4.....25C930(E,F)
 TR5.....25C3000(E,F)
 TR6,10,18,24to26
 ...25C536K-NP(E,F,G)
 TR9,23...25A608K-NP(E,F,G)
 TR21.....25D571(L,M)
 TR22.....25D313HP(E,F)
 TR27.....25K223(E,F)
 TR35.....25K270

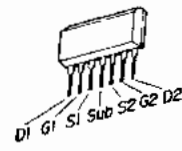

25K270



35K73



25K212



25K223



25C2999



25A608K-NP
 25C536K-NP
 25C930
 25C3000



25D571

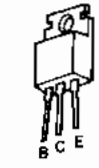

25D313

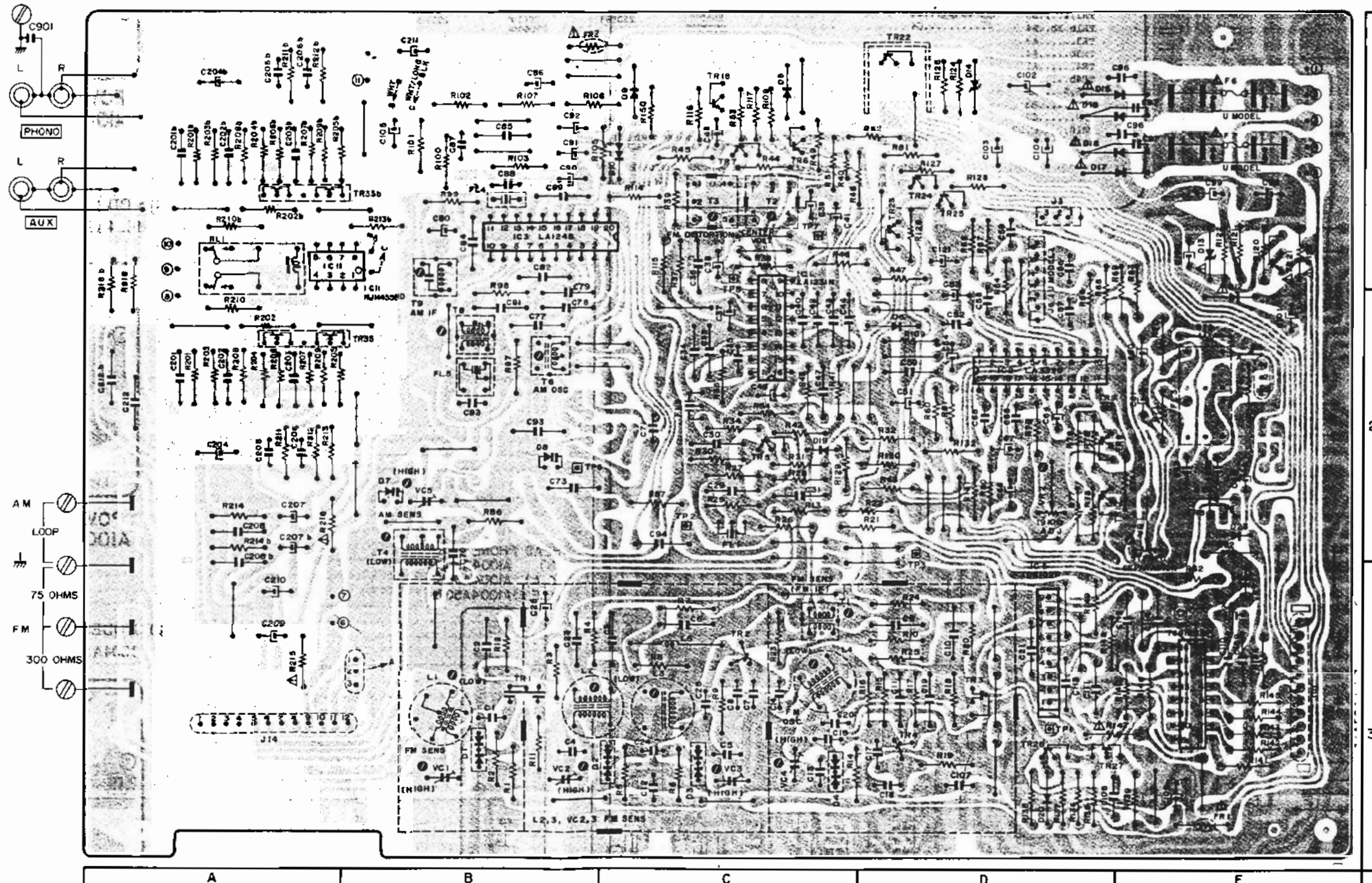

WARNING: Δ INDICATES SAFETY CRITICAL COMPONENTS FOR CONTINUED SAFETY. REPLACE SAFETY CRITICAL COMPONENTS ONLY WITH MANUFACTURER'S RECOMMENDED PARTS.
 AVERTISSEMENT: Δ IL INDIQUE LES COMPOSANTS CRITIQUES DE SÉCURITÉ POUR MAINTENIR LE DEGRÉ DE SÉCURITÉ DE L'APPAREIL. NE REMPLACER QUE DES PIÈCES RECOMMANDÉES PAR LE FABRICANT.

TUNER PCB(U) A1005A5040
 (A,C) A1005A5041
 (S) A1005A5042

2) CONTROL P.C BOARD A1004A5040 (3ED)

LOCATION OF COMPONENTS

IC	TR	J
IC1---D3	TR1---D3	J1---B3
IC2---D/E 1	TR2---B1	J2---E2
IC3---C3	TR3,4---D3	J3,4---E3
IC4---C2		J5---D1
IC5---E2		J6---D2
IC6---E3		J7---C3
IC7---E2		J8---C2
IC8---E1		J9---C1
IC9---C1		J10---E1
IC10---E3		J11---D2
IC11---B3		J12---E2
IC12,13---B2		J13---D2
IC14---B3		J14---A2
IC15---A2		
IC16,17---A3		

TERMINAL

①,②---C2
③---D2
④,⑤,⑥---E3
⑧ to ⑩---A1
⑦---D3



2SC536K-NP
2SA608K-NP

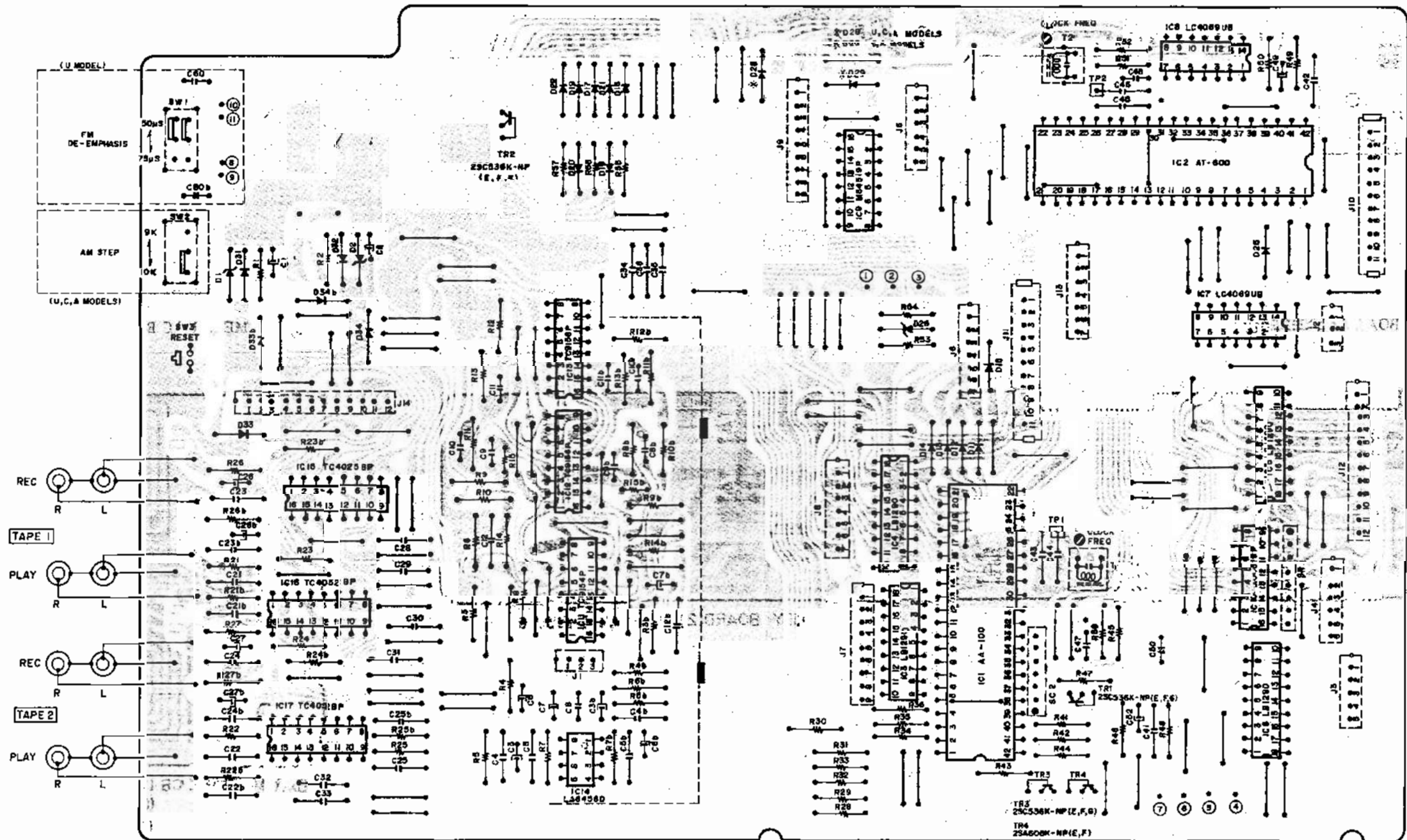
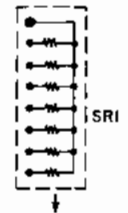
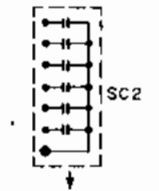

CONTROL PCB A1004A5040

3) KEY BOARD (1) P.C BOARD A1004A5020

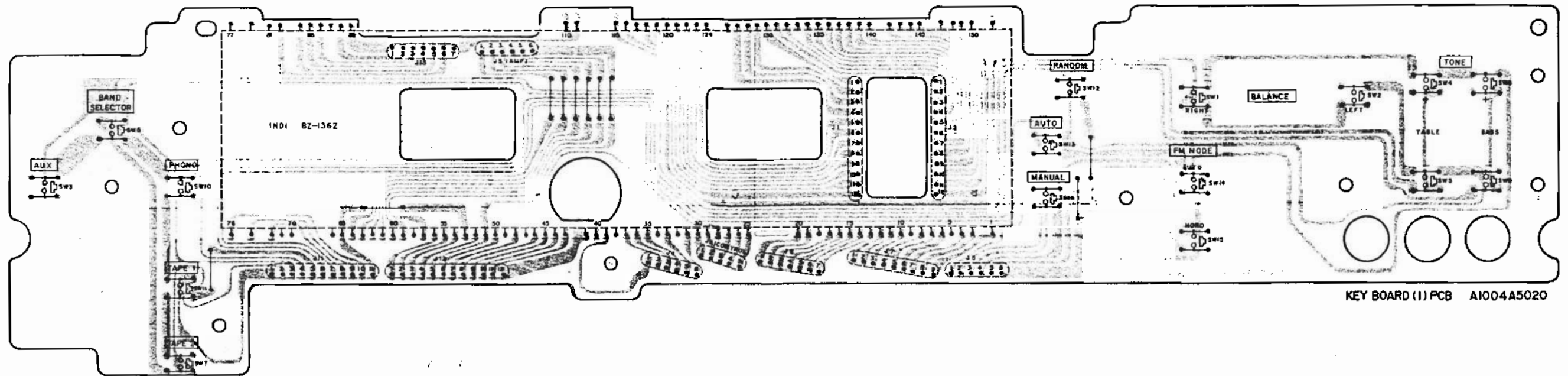

KEY BOARD (1) PCB A1004A5020

4) KEY BOARD (2) P.C BOARD A1004B5010

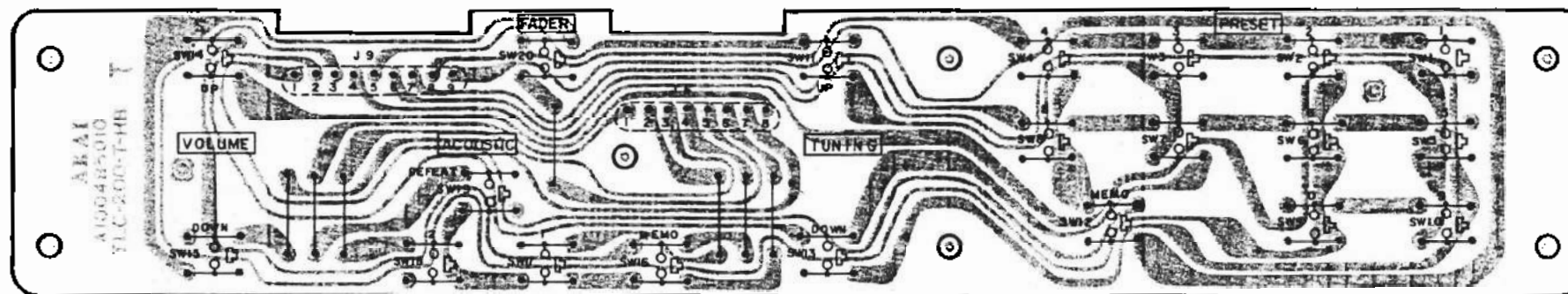

KEY BOARD(2) PCB A1004B5010

5) BAR METER P.C BOARD A1005A501C, 2C, 3C

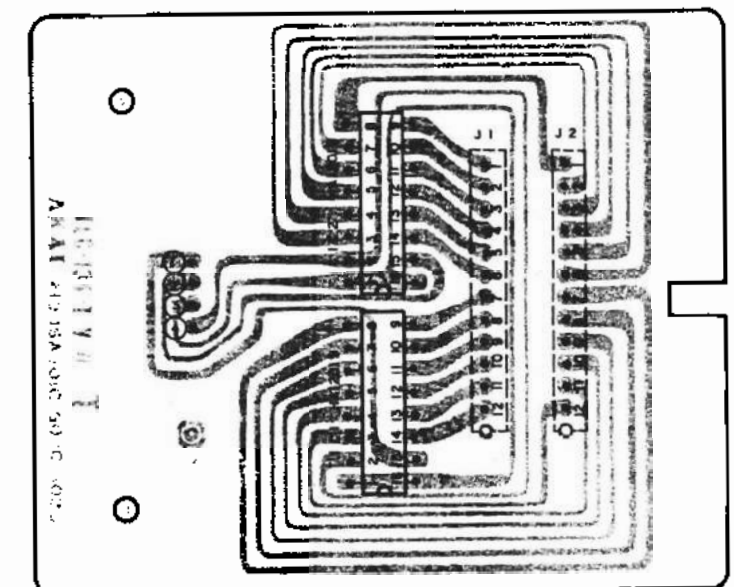

BAR METER PCB (U) A1005A501C
(C, A) A1005A502C
(S) A1005A503C

6) MAIN AMP P.C BOARD A1005A501A, 2A, 3A(3ED) and HEADPHONE P.C BOARD A1005A501B, 2B, 3B

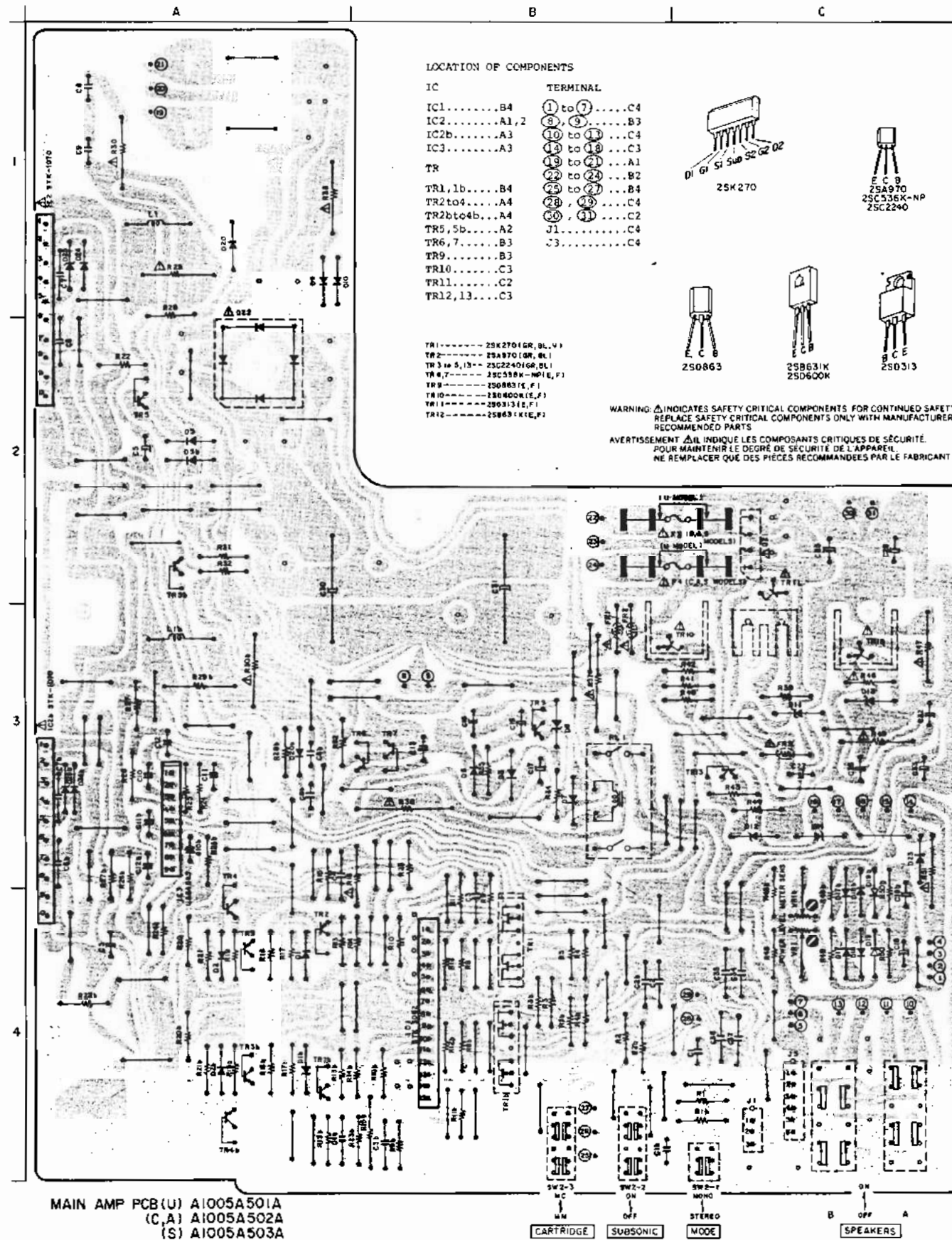

7) POWER P.C BOARD (U) A1005A501D

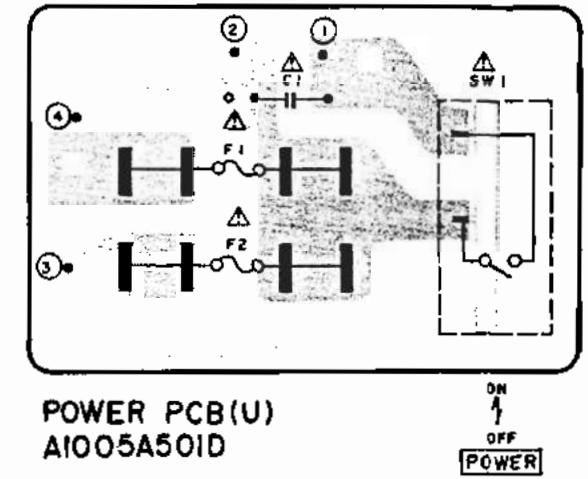

8) POWER P.C BOARD (C, A) A1005A502D

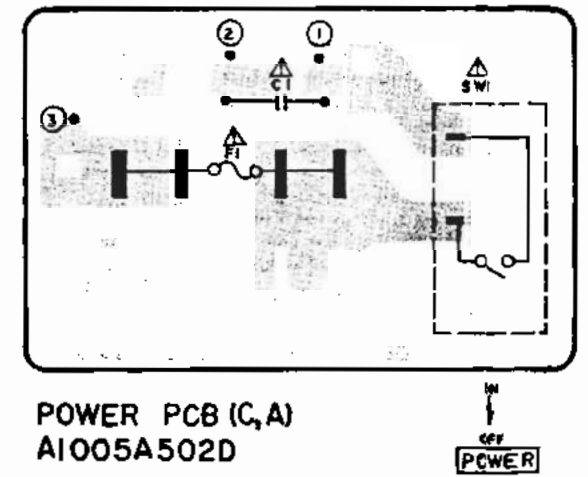

HEAD PHONE PCB (U) A1005A501B (C, A) A1005A502B (S) A1005A503B



9) POWER P.C BOARD (S) A1005A503D

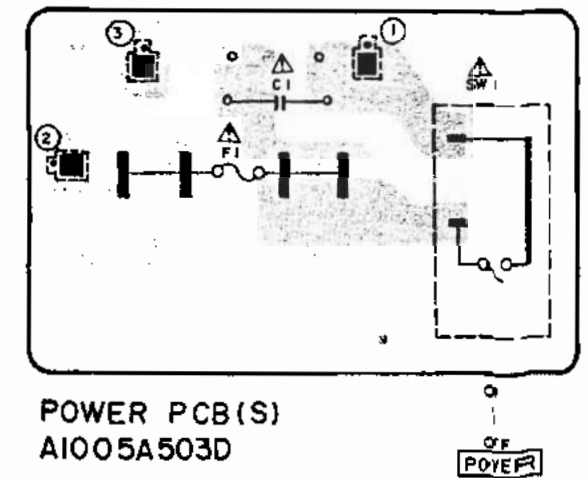

SECTION 4

PARTS LIST

TABLE OF CONTENTS

I. MODEL AA-R22/L	
RECOMMENDED SPARE PARTS	77
1. TUNER P.C BOARD BLOCK	78
2. CONTROL P.C BOARD BLOCK	79
3. MAIN AMP P.C BOARD BLOCK	79
4. EQ P.C BOARD BLOCK	79
5. ASSEMBLY BLOCK	80
6. FINAL ASSEMBLY BLOCK	82
II. MODEL AA-R32/L	
RECOMMENDED SPARE PARTS	83
1. TUNER EQ P.C BOARD BLOCK	84
2. MAIN AMP P.C BOARD BLOCK	85
3. CONTROL P.C BOARD BLOCK	85
4. KEY BOARD (1) P.C BOARD BLOCK	85
5. KEY BOARD (2) P.C BOARD BLOCK	85
6. POWER P.C BOARD BLOCK	85
7. ASSEMBLY BLOCK	86
8. FINAL ASSEMBLY BLOCK	88
III. MODEL AA-R42	
RECOMMENDED SPARE PARTS	89
1. TUNER EQ P.C BOARD BLOCK	90
2. MAIN AMP P.C BOARD BLOCK	91
3. CONTROL P.C BOARD BLOCK	91
4. POWER P.C BOARD BLOCK	91
5. KEY BOARD (1) P.C BOARD BLOCK	91
6. KEY BOARD (2) P.C BOARD BLOCK	91
7. ASSEMBLY BLOCK	92
8. FINAL ASSEMBLY BLOCK	94
INDEX	
1. MODEL AA-R22/L	95
2. MODEL AA-R32/L	96
3. MODEL AA-R42	97

Resistor and Capacitor which is not listed in this parts list, please refer to COMMON LIST FOR SERVICE PARTS.

ATTENTION

1. When placing an order for parts, be sure to list the parts no., model no., and description. There are instances in which if any of this information is omitted, parts cannot be shipped or the wrong parts will be delivered.
2. Please be careful not to make a mistake in the parts no. If the parts no. is in error, a part different from the one ordered may be delivered.
3. Because parts number and parts unit supply in the Preliminary Parts List may be partially changed, please use this parts list for all future reference.

HOW TO USE THIS PARTS LIST

1. This Parts List shows the parts that are considered necessary for repairs. Other parts, such as resistors and capacitors, are shown in the "Common List for Service Parts". Select and order such parts from the "Common List for Service Parts".
2. The Recommended Spare Parts shows those parts in the Parts List which are considered particularly important for service.
3. Parts not shown in the Parts List and "Common List for Service Parts" will not be supplied in principle.
4. How to read list
 - a) Mechanism Block
 - b) P.C Board Block

2. HEAD BASE BLOCK

REF. NO.	PARTS NO.	DESCRIPTION
2-1x	BH-T2023A320A	HEAD BASE BLOCK GX-F66R
2-2	HP-H2206A010A	HEAD R/P PR4-8FU C
2-3	ZS-477876	PAN20x03STL CMT
2-4	ZS-536488	BID20x08STL CMT
2-5	ZG-402895	CS ANGLE ADJUST SPRING

SP (Service Parts) Classification

A small "x" indicates the inability to show that particular part in the Photo or Illustration.

This number corresponds with the individual parts index number in that figure

This number corresponds with the Figure Number

6. SYS. CON. P.C BOARD BLOCK

REF. NO.	PARTS NO.	DESCRIPTION
6-1	BA-T2034A070A	PC SYS CON BLK GX-F44R
6-IC1	EI-324536	IC HD14049BP
6-IC2	EI-336801	IC MB8841-564M
6-IC3	EI-331661	IC SN7405N
6-IC4	EI-336725	IC M54527P
6-TR1to4	ET-200985	TR 2SC2603 F,G
6-TR5to28	ET-554657	TR 2SA733A P,Q
6-D1	ED-318292	D SILICON H 1S2473T-77 T26
6-D2to4	ED-308952	D GERMA V 1K34A-LR F07
6-D5to10	ED-318292	D SILICON H 1S2473T-77 T26
6-X1	EI-318384	OSC X'TAL NC-18C 3.579545MHZ

SP (Service Parts) Classification

This reference numbers corresponds with symbol numbers of Schematic Diagrams.

5. Both the kind of part and installation position can be determined by the Parts Number. To determine where a parts number is listed, utilize Parts Index at end of Parts List. It is necessary first of all to find the Parts Number. This can be accomplished by using the Reference Number listed at right of parts number in the Parts Index.

WARNING

△ INDICATES SAFETY CRITICAL COMPONENTS. FOR CONTINUED SAFETY, REPLACE SAFETY CRITICAL COMPONENTS ONLY WITH MANUFACTURER'S RECOMMENDED PARTS.

AVERTISSEMENT

△ IL INDIQUE LES COMPOSANTS CRITIQUES DE SÉCURITÉ. POUR MAINTENIR LE DEGRÉ DE SÉCURITÉ DE L'APPAREIL, NE REMPLACER QUE DES PIÈCES RECOMMANDÉES PAR LE FABRICANT.

I. AA-R22/L

RECOMMENDED SPARE PARTS

Because, if the parts listed below are on hand, almost any repair can be accomplished, we suggest that you stock these Recommended Spare Parts Items.

NO.	PARTS NO.	DESCRIPTION	NO.	PARTS NO.	DESCRIPTION
1	BT-343358	Δ TRANS POWER AA-R22T-20 (A)	68	EO-336871	COIL VARI 2 TFEI-ISC-U
2	BT-343357	Δ TRANS POWER AA-R22T-30 (C)	69	EO-336873	COIL VARI 2 TFEI-RF-1
3	BT-343359	Δ TRANS POWER AA-R22T-40 (E)	70	EO-336938	COIL VARI 2 TFEI-RF-2
4	BT-343360	Δ TRANS POWER AA-R22T-50 (S,B)	71	EO-337598	COIL VARI 2 25A-1353-01
5	BT-343356	Δ TRANS POWER AA-R22T-70 (U)	72	EO-337599	COIL VARI 2 25A-1354-03
6	EC-344480	C COMP 05-0009	73	ER-337327	FILTER CE BFU459C4N 0.459MHZ
7	EC-344157	C DOUBLE LAYER 473Z 5.5DC	74	ER-337328	FILTER CE BFU460C4N 0.46MHZ
8	EC-330692	C S-FIX H TZ03R200E 4.2-20	75	ER-336804	FILTER CE SFE10.7MA8 10.7MHZ
9	EC-337772	C S-FIX H TZ03Z070E 2.0-7	76	ER-343352	FILTER CE SFU459B9 0.459MHZ
10	ED-336805	Δ D SILICON DS135D-KB1 200/1.0A	77	ER-343353	FILTER CE SFU460B9 0.460MHZ
11	ED-343413	Δ D ZENER H 05Z15 X, Y	78	ER-341654	FILTER LC LP 42W-1001
12	ED-343412	Δ D ZENER H 05Z6.2 X, Y	79	ER-315407	FILTER CE SFE10.7MMKA 10.7MHZ
13	ED-200213	D SILICON DBA40C-K15 200/2.6A	80	ER-343420	R COMP EXB-P84104K
14	ED-200469	D SILICON H DS448 FA5 F10	81	ER-343419	R COMP EXB-P86104K
15	ED-200468	D SILICON V DS448-VB6	82	ES-343689	Δ SW PUSH ESB-90164T 01-1UC (C,A)
16	ED-336832	D VARACTOR SVC211SP	83	ES-343688	Δ SW PUSH ESB-90279S 01-1EBV (U,S,E,B)
17	ED-337605	D VARACTOR SVC333 (A) DOUBLE	84	ES-343364	Δ SW SELECTA 0240#01 01.4
18	ED-323057	D VARISTER MV12	85	ES-343377	SW PUSH SUL232A 2 THROW
19	ED-345149	D ZENER H HZ15L 3	86	ES-343367	SW SLIDE HSW 0700-30 1-01-02N
20	ED-337990	D ZENER H HZ27L 1	87	ES-343366	SW SLIDE HSW0700-010 2-02-02N
21	ED-343854	D ZENER H HZ30L 2	88	ES-328777	SW TACT EVQ-PYR12K
22	ED-343410	D ZENER H HZ6L A1	89	ES-336780	SW TACT KHH10902
23	ED-307690	D ZENER H HZ7L A1	90	ET-324134	Δ TR 2SA984K E,F
24	ED-300257	D ZENER H 05Z6.8 X	91	ET-322598	Δ TR 2SB632K E,F
25	ED-346060	D ZENER H 05Z7.5 X, Y	92	ET-452531	Δ TR 2SD313 E,F
26	EE-337976	ANT LOOP LA-200A	93	ET-655356	Δ TR 2SD571 L,M
27	EF-325683	Δ FUSE GGS A 125V 5A (C,A) F3	94	ET-318239	Δ TR 2SD863 E,F
28	EF-668474	Δ FUSE SEMKO T 250V 0.40A (S,E,B) F6,7	95	ET-330588	TR FET 2SK19 O,Y
29	EF-602550	Δ FUSE SEMKO T 250V 1.25A (S,E,B) F1	96	ET-336937	TR FET 2SK223 E,F
30	EF-601301	Δ FUSE SEMKO T 250V 2A (S,E,B) F4,5	97	ET-336867	TR FET 3SK73 Y
31	EF-249851	Δ FUSE SEMKO T 250V 5A (S,E,B) F3	98	ET-323529	TR 2SA608K-NP E,F
32	EF-311839	Δ FUSE TSC A 250V 1.6A (U) F1,2	99	ET-322778	TR 2SA608K-NP E,F,G
33	EF-306951	Δ FUSE TSC A 250V 2.5A (U) F4,5	100	ET-337038	TR 2SA608KAANP E,F,G T05
34	EF-326613	Δ FUSE TSC A 250V 5A (U) F3	101	ET-338410	TR 2SC2878 A,B
35	EF-309390	Δ FUSE TSC 125V 0.50A (C,A) F6,7	102	ET-336869	TR 2SC2999 C,D
36	EF-306956	Δ FUSE TSC 125V 2.5A (C,A) F4,5	103	ET-336935	TR 2SC3000 E,F
37	EF-306957	Δ FUSE TSC 125V 4A (C,A) F1	104	ET-322775	TR 2SC536K-NP E,F,G
38	EI-343381	Δ IC STK-4833ST	105	ET-337036	TR 2SC536KNPAA E,F,G T05
39	EI-343374	IC AA-100	106	ET-342707	TR 2SC536NP E,F
40	EI-337600	IC AT600	107	ET-621235	TR 2SC536NP E,F,G
41	EI-322248	IC LA1231N	108	ET-618873	TR 2SC930 E,F
42	EI-202218	IC LA1245	109	ET-337744	TR 2SK212 D,E
43	EI-343349	IC LA3390	110	EV-337995	R S-FIX H RVF8P01 3P 103
44	EI-336761	IC LA6458S	111	EV-337993	R S-FIX H RVF8P01 3P 203
45	EI-336794	IC LB1240			
46	EI-343417	IC LB1294			
47	EI-338171	IC LC4069UB			
48	EI-344764	IC M5218P-21			
49	EI-300042	IC M54519P			
50	EI-322599	IC TA7545SS			
51	EI-332259	IC TC4052BP			
52	EI-336717	IC TC9125BP			
53	EI-343371	IC TC9154P			
54	EI-343373	IC TC9156P			
55	EI-315381	IC TD6102P			
56	EI-327074	OSC X'TAL HC-18/U 9MHZ			
57	EM-343376	IND FL BG-135ZK			
58	EO-336878	COIL DET 2 78-1049			
59	EO-336879	COIL DET 2 78-1050			
60	EO-332120	COIL FIX 2 103AK-005A 2.20μH			
61	EO-343351	COIL IFT PEGK0008B-01 455.0KC			
62	EO-336831	COIL IFT 119A-15266X 10.7MC			
63	EO-202216	COIL IFT 7MC-6733C 460KHZ			
64	EO-336833	COIL IFT 7MC-7736Z 460KHZ			
65	EO-202215	COIL OSC 2 7NR-6721Y 100μH			
66	EO-307786	COIL OSC 2 7NR-6722Y 580μH			
67	EO-336872	COIL VARI 2 TFEI-ANT-U			

1. TUNER P.C BOARD BLOCK

REF. NO.	PARTS NO.	DESCRIPTION	REF. NO.	PARTS NO.	DESCRIPTION
1-1	BA-A1003A070A	PC TUNER BLK AA-R22(U)	1-FL5	ER-343353	FILTER CE SFU460B9 0.460MHZ (C,A)
1-1	BA-A1003A070B	PC TUNER BLK AA-R22(C,A)	1-X1	EI-327074	OSC X'TAL HC-18/U 9MHZ
1-1	BA-A1003A070C	PC TUNER BLK AA-R22(S)	1-VC1to4	EC-337772	C S-FIX H TZ03Z070E 2.0-7
1-1	BA-A1003A070D	PC TUNER BLK AA-R22L(E,B)	1-VC5	EC-330692	C S-FIX H TZ03R200E 4.2-20
1-IC1	EI-322248	IC LA1231N	1-VC6	EC-330692	C S-FIX H TZ03R200E 4.2-20 (AA-R22L)
1-IC2	EI-343349	IC LA3390	1-VC7	EC-330692	C S-FIX H TZ03R200E 4.2-20
1-IC3	EI-202218	IC LA1245	1-R21,22	ER-324337	Δ RCBHS10 FS RDS 1/4W 560J
1-IC4	EI-336717	IC TC9125BP	1-R32,33	ER-324337	Δ RCBHS10 FS RDS 1/4W 560J
1-IC5	EI-315381	IC TD6102P	1-R46,47	ER-324337	Δ RCBHS10 FS RDS 1/4W 560J
1-TR1	ET-336867	TR FET 3SK73 Y	1-R60,61	ER-324337	Δ RCBHS10 FS RDS 1/4W 560J
1-TR2	ET-336869	TR 2SC2999 C,D	1-R100	ER-324185	Δ RCBHS10 FS RDS 1/4W 221J
1-TR3	ET-337744	TR 2SK212 D,E	1-R101	ER-324184	Δ RCBHS10 FS RDS 1/4W 121J
1-TR4	ET-618873	TR 2SC930 E,F	1-R120	ER-322787	Δ RCBHS10 FS RDS 1/4W 100J
1-TR5	ET-336935	TR 2SC3000 E,F	1-R123	ER-322421	Δ RCBHS10 FS RDS 1/4W 820J
1-TR6,7	ET-621235	TR 2SC536NP E,F,G	1-R147	ER-325114	Δ RCBHS10 FS RDS 1/4W 330J
1-TR8to10	ET-337036	TR 2SC536KNPAA E,F,G T05	1-FR1	ER-318248	Δ R FUSE ERD2FC S10 1/4W 47R0G
1-TR11	ET-338410	TR 2SC2878 A,B (AA-R22L)	1-C56	EC-344486	C PP V F05 PP 391J 50DC (U,S,E,B)
1-TR12to15	ET-322778	TR 2SA608K-NP E,F,G(AA-R22L)	1-C56	EC-344478	C PP V F05 PP 561J 50DC (C,A)
1-TR16	ET-322775	TR 2SC536K-NP E,F,G(AA-R22L)	1-C57	EC-344486	C PP V F05 PP 391J 50DC (U,S,E,B)
1-TR17	ET-330588	TR FET 2SK19 O,Y (AA-R22L)	1-C57	EC-344478	C PP V F05 PP 561J 50DC (C,A)
1-TR18to20	ET-322775	TR 2SC536K-NP E,F,G(AA-R22L)	1-C62,63	EC-344484	C PP V F05 PP 392J 50DC
1-TR21	ET-655356	Δ TR 2SD571 L,M	1-C65	EC-344483	C PP V F05 PP 102J 50DC
1-TR22	ET-452531	TR 2SD313 E,F	1-C71	EC-344481	C PP V F05 PP 4700G 50DC
1-TR23to26	ET-322778	TR 2SA608K-NP E,F,G	1-C72	EC-344482	C PP V F05 PP 161J 50DC (AA-R22L)
1-TR27	ET-336937	TR FET 2SK223 E,F			
1-TR28	ET-322775	TR 2SC536K-NP E,F,G(AA-R22L)			
1-TR29	ET-322778	TR 2SA608K-NP E,F,G			
1-TR30	ET-322775	TR 2SC536K-NP E,F,G			
1-D1to4	ED-336832	D VARACTOR SVC211SP			
1-D5,6	ED-301911	D SILICON H DS448			
1-D7,8	ED-337605	D VARACTOR SVC333 (A) DOUBLE			
1-D9	ED-301911	D SILICON H DS448			
1-D10	ED-323057	D VARISTER MV12			
1-D12	ED-343412	D ZENER H 05Z6.2 X,Y			
1-D13	ED-343412	Δ D ZENER H 05Z6.2 X,Y			
1-D14	ED-343413	Δ D ZENER H 05Z15 X,Y			
1-D15to18	ED-336805	Δ D SILICON DS135D-KB1 200/1.0A			
1-D19to23	ED-301911	D SILICON H DS448			
1-D24	ED-346060	D ZENER H 05Z7.5 X,Y			
1-D25	ED-301911	D SILICON H DS448 (AA-R22L)			
1-TM1	EJ-309941	TERMINAL W/SCREW UB-1059 P 4P			
1-VR1	EV-337993	R S-FIX H RVF8P01 3P 203			
1-VR2	EV-337995	R S-FIX H RVF8P01 3P 103			
1-L1	EO-336872	COIL VARI 2 TFEI-ANT-U			
1-L2	EO-336873	COIL VARI 2 TFEI-RF-1			
1-L3	EO-336938	COIL VARI 2 TFEI-RF-2			
1-L4	EO-336871	COIL VARI 2 TFEI-OSC-U			
1-L5	EO-332120	COIL FIX 2 103AK-005A 2.20μH			
1-T1	EO-336831	COIL IFT 119AC-15266X 10.7MC			
1-T2	EO-336878	COIL DET 2 78-1049			
1-T3	EO-336879	COIL DET 2 78-1050			
1-T4	EO-337598	COIL VARI 2 25A-1353-01			
1-T5	EO-337599	COIL VARI 2 25A-1354-03 (AA-R22L)			
1-T6	EO-202215	COIL OSC 2 7NR-6721Y 100μH			
1-T7	EO-307786	COIL OSC 2 7NR-6722Y 580μH (AA-R22L)			
1-T8	EO-343351	COIL IFT PEGK0008B-01 455.0KC			
1-T9	EO-202216	COIL IFT 7MC-6733C 460KHZ			
1-FL1	ER-315407	FILTER CE SFE10.7MMKA 10.7MHZ			
1-FL2	ER-336804	FILTER CE SFE10.7MA8 10.7MHZ			
1-FL3	ER-341654	FILTER LC LP 42W-1001			
1-FL4	ER-337327	FILTER CE BFU459C4N 0.459MHZ (U,S,E,B)			
1-FL4	ER-337328	FILTER CE BFU460C4N 0.46MHZ (C,A)			
1-FL5	ER-343352	FILTER CE SFU459B9 0.459MHZ (U,S,E,B)			

2. CONTROL P.C BOARD BLOCK

REF. NO.	PARTS NO.	DESCRIPTION
2-1	BA-A1003A030A	PC CONTROL BLK AA-R22(U)
2-1	BA-A1003A030B	PC CONTROL BLK AA-R22(C,A)
2-1	BA-A1003A030C	PC CONTROL BLK AA-R22(S)
2-1	BA-A1003A030D	PC CONTROL BLK AA-R22L (E,B)
2-IC1	EI-336761	IC LA6458S
2-IC2,3	EI-343373	IC TC9156P
2-IC4	EI-343371	IC TC9154P
2-IC5	EI-343374	IC AA-100
2-IC6to8	EI-343417	IC LB1294
2-IC9	EI-338171	IC LC4069UB
2-IC10	EI-337600	IC AT600
2-IC11,12	EI-336794	IC LB1240
2-IC13	EI-343417	IC LB1294
2-IC14	EI-300042	IC M54519P
2-IC15	EI-338171	IC LC4069UB
2-TR1,2	ET-342707	TR 2SC536NP E,F
2-D1,2	ED-343410	D ZENER H HZ6L A1
2-D3to10	ED-301911	D SILICON H DS448
2-D11	ED-200469	D SILICON H DS448 FA5 F10 (U,C,A)
2-D12	ED-200469	D SILICON H DS448 FA5 F10 (AA-R22L) (C,A)
2-D13	ED-200469	D SILICON H DS448 FA5 F10 (C,A)
2-D14	ED-300257	D ZENER H 05Z6.8 X
2-T1,2	EO-336833	COIL IFT 7MC-7736Z 460KHZ
2-SR1	ER-343420	R COMP EXB-P84104K
2-SR2to4	ER-343419	R COMP EXB-P86104K
2-SC1	EC-344480	C COMP 05-0009
2-R12,13	ER-325269	R CB H S10 FS RDS 1/4W 222J
2-C13	EC-344157	C DOUBLE LAYER 473Z 5.5DC
2-SW2to4	ES-336780	SW TACT KHH10902
2-SW6to12	ES-336780	SW TACT KHH10902
2-SW14to20	ES-336780	SW TACT KHH10902
2-SW26,29	ES-336780	SW TACT KHH10902
2-IND1	EM-343376	IND FL BG-135ZK
2-SW1	ES-336780	SW TACT KHH10902
2-SW5,13	ES-336780	SW TACT KHH10902
2-SW21to25	ES-336780	SW TACT KHH10902
2-SW27,28	ES-336780	SW TACT KHH10902
2-SW30,31	ES-336780	SW TACT KHH10902

3. MAIN AMP P.C BOARD BLOCK

REF. NO.	PARTS NO.	DESCRIPTION
3-1	BA-A1003A060A	PC MAIN AMP BLK AA-R22(U)
3-1	BA-A1003A060B	PC MAIN AMP BLK AA-R22(C,A)
3-1	BA-A1003A060C	PC MAIN AMP BLK AA-R22(S)
3-1	BA-A1003A060D	PC MAIN AMP BLK AA-E22-P(U)
3-1	BA-A1003A060E	PC MAIN AMP BLK AA-R22-P (C,A)
3-1	BA-A1003A060F	PC MAIN AMP BLK AA-R22-P(S)
3-1	BA-A1003A060G	PC MAIN AMP BLK AA-R22L (E,B)
3-1	BA-A1003A060H	PC MAIN AMP BLK AA-R22L-P (E,B)
3-IC1	EI-322599	IC TA75458S
3-TR1	ET-318239	Δ TR 2SD863 E,F
3-TR2	ET-324134	Δ TR 2SA984K E,F
3-TR3	ET-322598	Δ TR 2SB632K E,F
3-TR4	ET-323529	TR 2SA608K-NP E,F

REF. NO.	PARTS NO.	DESCRIPTION
3-D1,2	ED-345149	D ZENER H HZ15L 3
3-D3	ED-337990	D ZENER H HZ27L 1
3-D4	ED-345149	D ZENER H HZ15L 3
3-D5,6	ED-343854	D ZENER H HZ30L 2
3-D7	ED-200213	D SILICON DBA40C-K15 200/2.6A
3-D8,9	ED-330207	D SILICON H DS448BT T26
3-SW1	ES-343377	SW PUSH SUL232A 2 THROW
3-SW2	ES-343688	Δ SW PUSH ESB-90279S 01-1EBV (U,S,E,B)
3-SW2	ES-343689	Δ SW PUSH ESB-90164T 01-1UC (C,A)
3-L1	EO-337880	COIL FIX 2 202AK-018 2.20μH
3-TM1	EJ-343378	TERMINAL PUSH SQ-2783#01 P 8P
3-R7	ER-322591	Δ R CB H S10 FS RDS 1/4W 101J
3-R8	ER-200940	Δ R CB H S10 FS RDS 1/4W 561J
3-R10	ER-311685	Δ R CB H S15 FS RDS 1/2W 4R7J
3-R17	ER-321153	Δ R OMF H S15 FS 1W 102J
3-R18	ER-308028	Δ R OMF H S15 FS 1W 181J
3-R19	ER-306127	Δ R CB H S15 FS RDS 1/2W 681J
3-R20	ER-33363	Δ R CB H S10 FS RDS 1/4W 120J
3-R23	ER-306127	Δ R CB H S15 FS RDS 1/2W 681J
3-R26	ER-333625	Δ R CB H S15 FS RDS 1/2W 180J
3-R27	ER-328065	Δ R CB H SNP FS RDS 1/4W 182J
3-R28	ER-322787	Δ R CB H S10 FS RDS 1/4W 100J
3-C14	EC-325320	C EC V F05 NP AWA 2R2M 50DC
3-C16	EC-343976	C EC V T05 NP SM R22M 50DC
3-J2	EJ-343379	PHONE J 3P HLJ0541-930 6.3 (AA-R22/L)
3-J2	EJ-343380	PHONE J 3P HLJ0541-440 6.3 (AA-R22-P/L-P)
3-IC1	EI-343381	Δ IC STK-4833ST

4. EQ P.C BOARD BLOCK

REF. NO.	PARTS NO.	DESCRIPTION
4-1	BA-A1003A050A	PC EQ BLK AA-R22(U)
4-1	BA-A1003A050B	PC EQ BLK AA-R22(C,A)
4-1	BA-A1003A050C	PC EQ BLK AA-R22(S,B,E)
4-IC1	EI-344764	IC M5218P-21
4-IC2to4	EI-332259	IC TC4052BP
4-D1,2	ED-307690	D ZENER H HZ7L A1
4-SW1	ES-343366	SW SLIDE HSW0700-010 2-0 2-02N
4-SW2	ES-343367	SW SLIDE HSW 0700-30 1-0 1-02N
4-SW3	ES-328777	SW TACT EVQ-PYR12K
4-J1to3	EJ-343365	PIN J YMC21-0063 P 4P
4-R10	ER-325269	Δ R CB H S10 FS RDS1/4W 222J
4-R11	ER-323074	Δ R CB H S10 FS RDS1/4W 102J
4-C25	EC-344482	C PP V F05 PP 161J 50DC

ASSEMBLY BLOCK

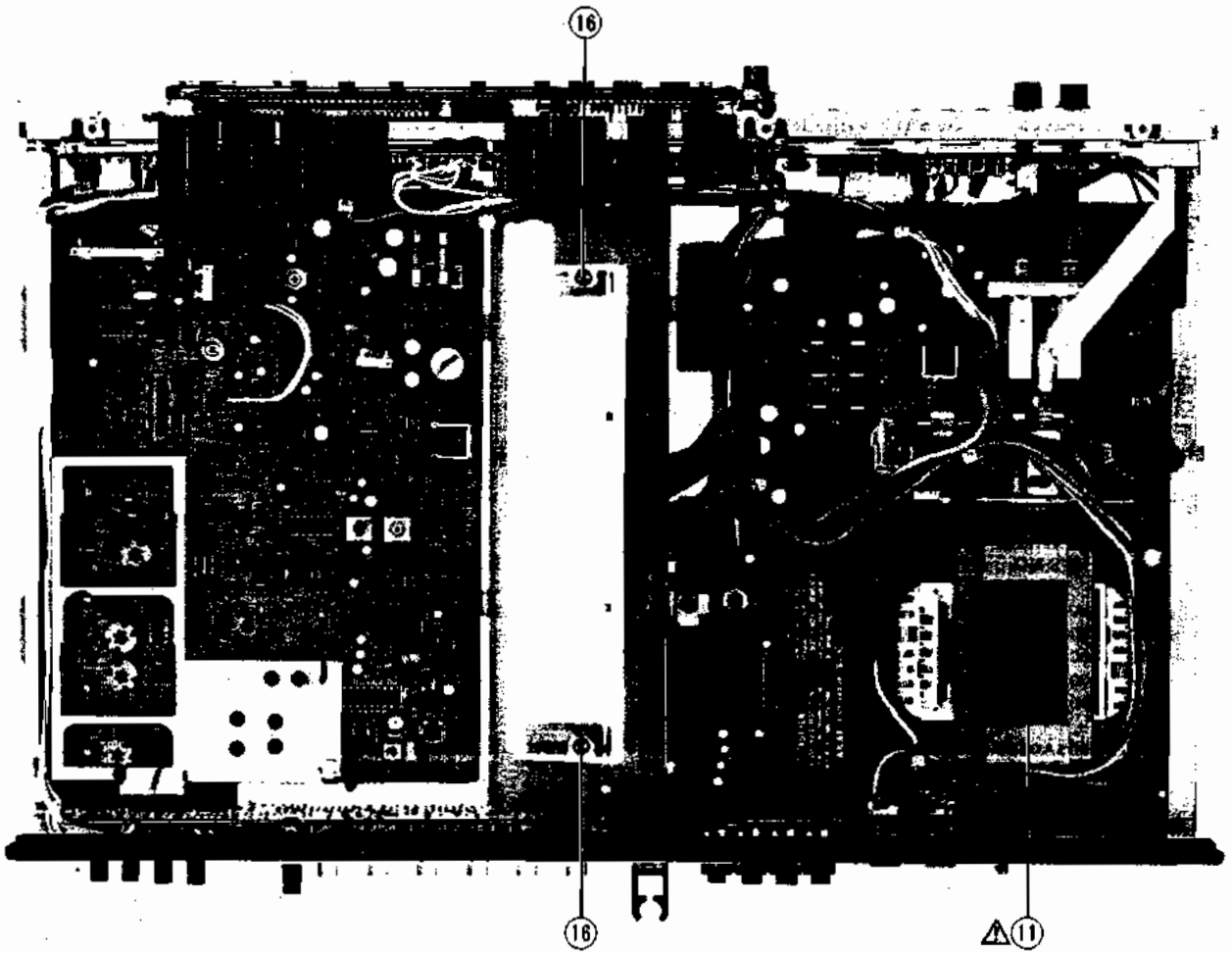
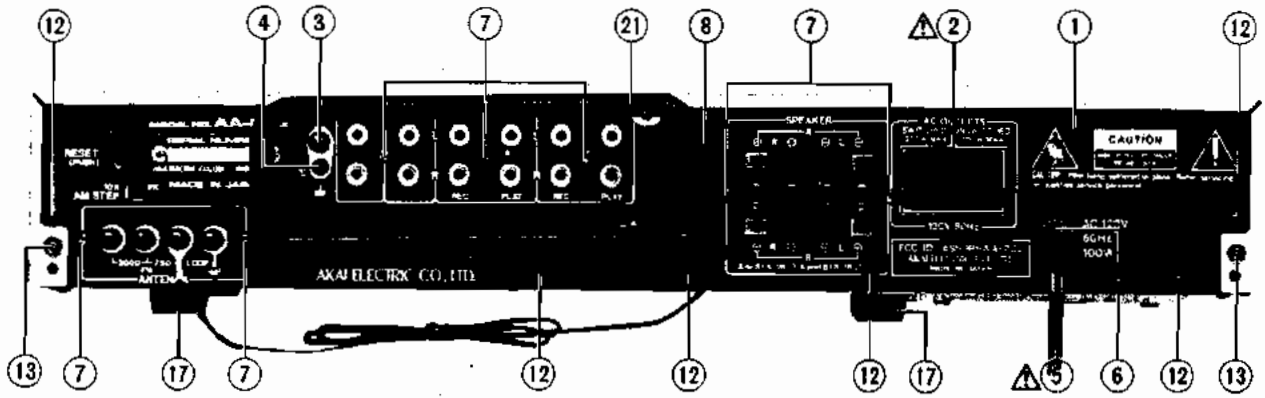

5. ASSEMBLY BLOCK

REF. NO.	PARTS NO.	DESCRIPTION
5-1	SP-342756A	PANEL REAR AA-R22(U)
5-1x	SP-342756B	PANEL REAR AA-R22(C)
5-1x	SP-342756C	PANEL REAR AA-R22(A)
5-1x	SP-342756F	PANEL REAR AA-R22(S)
5-1x	SP-342756D	PANEL REAR AA-R22(E)
5-1x	SP-342756E	PANEL REAR AA-R22(B)
5-2	EJ-343362	△ SOCKET OUTLET S2T732T174 JUC (U,C,A)
5-3	EJ-329610	TERMINAL W/SCREW UB-0067 L 1P
5-4	ZS-319460	T2BR30x06STL BZN PROJECTION
5-5	EW-306428	△ AC CORD 2 CORES KP-205A, VFF J (U)
5-5x	EW-343363	△ AC CORD 2 CORES KP-8, SPT-2 UC (C)
5-5x	EW-305691	△ AC CORD 2 CORES KP-8, SPT-1 UC (A)
5-5x	EW-336924	△ AC CORD 2 CORES KP-560, LTSA-2F (S)
5-5x	EW-336923	△ AC CORD 2 CORES KP-419C, LTCE-2F (E)
5-5x	EW-347025	△ AC CORD LTBS-2F 42/0.15x2 (B)
5-6	SZ-631945	STRAIN RELIEF SR-4N-4
5-7	ZS-309315	T2BR30x10STL BNI
5-8	SZ-332739	HOLDER ANTENNA
5-9x	ES-343364	△ SW SELECTA 0240#01 01-4(U)
5-10x	ZS-309315	T2BR30x10STL BNI
5-11	BT-343356	△ TRANS POWER AA-R22T-70(U)
5-11x	BT-343357	△ TRANS POWER AA-R22T-30(C)
5-11x	BT-343358	△ TRANS POWER AA-R22T-20(A)
5-11x	BT-343360	△ TRANS POWER AA-R22T-50(S,B)
5-11x	BT-343359	△ TRANS POWER AA-R22T-40(E)
5-12	ZS-319460	T2BR30x06STL BZN PROJECTION
5-13	ZS-463353	T2BR30x08STL BNI
5-14x	FR-233583	△ R SD 1/2W 225K(C,A)
5-15x	ZS-463353	T2BR30x08STL BNI
5-16	ZS-332541	SCREW HEAT SINK
5-17	SA-332850	ROUND FOOT
5-18x	ZS-565942	T2PAN40x08STL CMT
5-19x	ZS-498273	T2BR30x08STL CMT PW080
5-20x	EF-311839	△ FUSE TSC A 250V 1.6A (U)(F1,2)
5-20x	EF-326613	△ FUSE TSC A 250V 5A (U)(F3)
5-20x	EF-306951	△ FUSE TSC A 250V 2.5A (U)(F4,5)
5-20x	EF-325683	△ FUSE GGS A 125V 5A (C,A)(F3)
5-20x	EF-306956	△ FUSE TSC 125V 2.5A (C,A)(F4,5)
5-20x	EF-306957	△ FUSE TSC 125V 4A (C,A)(F1)
5-20x	EF-309390	△ FUSE TSC 125V 0.50A (C,A)(F6,7)
5-20x	EF-602550	△ FUSE SEMKO T 250V 1.25A (S,E,B)(F1)
5-20x	EF-249851	△ FUSE SEMKO T 250V 5A (S,E,B)(F3)
5-20	EF-601301	△ FUSE SEMKO T 250V 2A (S,E,B)(F4,5)
5-20x	EF-668474	△ FUSE SEMKO T 250V 0.40A (S,E,B)(F6,7)
5-21	EE-337976	ANT LOOP LA-200A

FINAL ASSEMBLY BLOCK

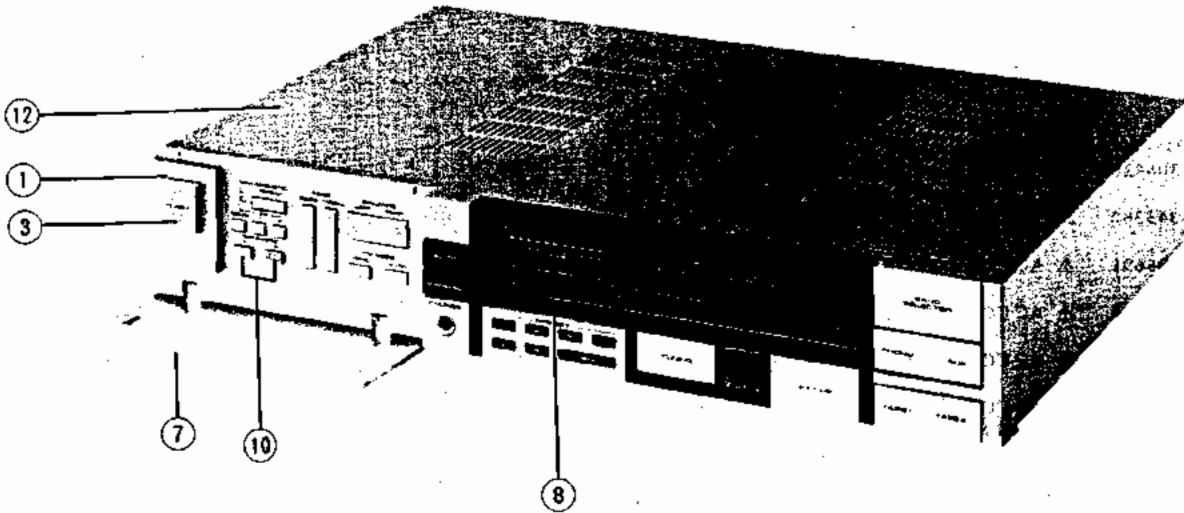

6. FINAL ASSEMBLY BLOCK

REF. NO.	PARTS NO.	DESCRIPTION
6-1	BD-A1003A100A	PANEL FRONT BLK AA-R22
6-1x	BD-A1003A100B	PANEL FRONT BLK AA-R22L
6-1x	BD-A1003A100C	PANEL FRONT BLK AA-R22-P
6-1x	BD-A1003A100D	PANEL FRONT BLK AA-R22L-P
6-2x	BD-B342760A	PANEL FRONT PART AA-R22
6-2x	BD-B342760B	PANEL FRONT PART AA-R22-P
6-3	SK-342820A	KNOB POWER
6-3x	SK-342820B	KNOB POWER-P
6-4x	ZG-322189	SPRING (B)
6-5x	SZ-342765A	HING DOOR PANEL (L)
6-5x	SZ-342765B	HING DOOR PANEL (L)-P
6-6x	SZ-342765C	HING DOOR PANEL (R)
6-6x	SZ-342765D	HING DOOR PANEL (R)-P
6-7	SP-342763A	PANEL DOOR AA-R22
6-7x	SP-342763C	PANEL DOOR AA-R22-L
6-7x	SP-342763B	PANEL DOOR AA-R22-P
6-7x	SP-342763D	PANEL DOOR AA-R22L-P
6-8	SZ-342762	WINDOW DISPLAY
6-9x	ZS-310343	PLX PAN30x06STL CMT
6-10	SK-342819A	KNOB PUSH
6-10x	SK-342819B	KNOB PUSH-P
6-11x	ZS-498273	T2BR30x08STL CMT PW080
6-12	SP-342759A	COVER UPPER
6-12x	SP-342759B	COVER UPPER-P
6-13x	ZS-308846	T2BR30x08STL BZN PROJECTION
6-14x	ZS-311745	T2BR30x08STL BNI PW080

II. AA-R32/L

RECOMMENDED SPARE PARTS

Because, if the parts listed below are on hand, almost any repair can be accomplished, we suggest that you stock these Recommended Spare Parts Items.

NO.	PARTS NO.	DESCRIPTION	NO.	PARTS NO.	DESCRIPTION
1	ED-346157	D ZENER H 05Z3.3 Y	68	EO-336872	COIL VARI 2 TFEI-ANT-U
2	EF-346139	Δ FUSE TSC 125V 5A (C,A) F1	69	EO-336871	COIL VARI 2 TFEI-OSC-U
3	BT-343386	Δ TRANS POWER AA-R32T-20 (A)	70	EO-336873	COIL VARI 2 TFEI-RF-1
4	BT-343385	Δ TRANS POWER AA-R32T-30 (C)	71	EO-336938	COIL VARI 2 TFEI-RF-2
5	BT-343387	Δ TRANS POWER AA-R32T-40 (E)	72	EO-337598	COIL VARI 2 25A-1353-01
6	BT-343388	Δ TRANS POWER AA-R32T-50 (S,B)	73	EO-337599	COIL VARI 2 25A-1354-03
7	BT-343384	Δ TRANS POWER AA-R32T-70 (U)	74	EP-337159	RELAY SIG G4Z-2282P 2NO 24V
8	EC-336882	C DOUBLE LAYER 104 5.5DC	75	ER-337327	FILTER CE BFU459C4N 0.459MHZ
9	EC-330692	C S-FIX H TZ03R200E 4.2-20	76	ER-337328	FILTER CE BFU460C4N 0.46MHZ
10	EC-337772	C S-FIX H TZ03Z070E 2.0-7	77	ER-336804	FILTER CE SFE10.7MA8 10.7MHZ
11	ED-200749	Δ D SILICON DBA60-K15 400/6.0A	78	ER-343354	FILTER CE SFZ459B3L 0.461MHZ
12	ED-336805	Δ D SILICON DS135D-KB1 200/1.0A	79	ER-343355	FILTER CE SFZ460B3L 0.462MHZ
13	ED-343413	Δ D ZENER H 05Z15 X,Y	80	ER-341654	FILTER LC LP 42W-1001
14	ED-343412	Δ D ZENER H 05Z2.2 X,Y	81	ER-315407	FILTER CE SFE10.7MMKA 10.7MHZ
15	ED-309341	D GERMA H 1K34A	82	ER-200941	R CB H S10 FS RDS 1/4W 271J
16	ED-338119	D SILICON H DS446BT T26	83	ER-325114	R CB H S10 FS RDS 1/4W 330J
17	ED-337153	D SILICON H DS446FA5 F10	84	ER-343409	R COMP EXB-P87103M
18	ED-200469	D SILICON H DS448 FA5 F10	85	ER-318248	R FUSE ERD2 FC S10 1/4W 47R0G
19	ED-330207	D SILICON H DS448BT T26	86	ES-343689	Δ SW PUSH ESB-90164T 01-1UC (C,A)
20	ED-200468	D SILICON V DS448-VB6	87	ES-343688	Δ SW PUSH ESB-90279S 01-1EBV (U,S,E,B)
21	ED-336832	D VARACTOR SVC211SP	88	ES-343364	Δ SW SELECTA 0240#01 01-4 (U)
22	ED-337605	D VARACTOR SVC333(A) DOUBLE	89	ES-343391	SW PUSH ESB-62902 2 THROW
23	ED-323057	D VARISTER MV12	90	ES-343392	SW PUSH SUL222A 2 THROW
24	ED-330218	D ZENER H HZ15L 2	91	ES-343398	SW SLIDE HSW0690-400 2-02-02N
25	ED-330219	D ZENER H HZ20L 2	92	ES-343399	SW SLIDE HSW0690-410 1-01-02N
26	ED-343410	D ZENER H HZ26L A1	93	ES-343400	SW TACT EVQ-QHR12K
27	ED-346116	D ZENER H 05Z13 Y	94	ES-336780	SW TACT KHH10902
28	ED-325115	D ZENER H 05Z15 L	95	ET-301165	Δ TR 2SB631K E,F
29	ED-344177	D ZENER H 05Z36 Y	96	ET-452531	Δ TR 2SD313 E,F
30	ED-323354	D ZENER H 05Z6.2	97	ET-655356	Δ TR 2SD571 L,M
31	EE-337976	ANT LOOP LA-200A	98	ET-300931	Δ TR 2SD600K E,F
32	EF-300599	Δ FUSE FST3100 T 250V 0.40A (S,E,B) F6	99	ET-330588	TR FET 2SK19 O,Y
33	EF-300599	Δ FUSE FST3100 T 250V 0.40A (S,E,B) F7	100	ET-336937	TR FET 2SK223 E,F
34	EF-601301	Δ FUSE SEMKO T 250V 2A (S,E,B) F1	101	ET-336867	TR FET 3SK73 Y
35	EF-326639	Δ FUSE TSC A 250V 3.15A (U) F1	102	ET-322778	TR 2SA608K-NP E,F,G
36	EF-326639	Δ FUSE TSC A 250V 3.15A (U) F2	103	ET-337038	TR 2SA608KAANP E,F,G T05
37	EF-309390	Δ FUSE TSC 125V 0.50A (C,A) F6	104	ET-305463	TR 2SA970 GR,BL
38	EF-309390	Δ FUSE TSC 125V 0.50A (C,A) F7	105	ET-307195	TR 2SC2240 GR,BL
39	EI-343390	Δ IC STK-1050	106	ET-338410	TR 2SC2878 A,B
40	EI-343374	IC AA-100	107	ET-336869	TR 2SC2999 C,D
41	EI-337600	IC AT600	108	ET-336935	TR 2SC3000 E,F
42	EI-315799	IC HA12019	109	ET-322775	TR 2SC536K-NP E,F,G
43	EI-322248	IC LA1231N	110	ET-337036	TR 2SC536KNPAA E,F,G T05
44	EI-202218	IC LA1245	111	ET-618873	TR 2SC930 E,F
45	EI-343349	IC LA3390	112	ET-452531	TR 2SD313 E,F
46	EI-344490	IC LA6458D	113	ET-328440	TR 2SD863-V8 E,F
47	EI-336761	IC LA6458S	114	ET-337744	TR 2SK212 D,E
48	EI-337013	IC LB1290	115	EV-315540	R S-FIX H D8 3P 502
49	EI-338171	IC LC4069UB	116	EV-337995	R S-FIX H RVF8P01 3P 103
50	EI-344764	IC M5218P-21	117	EV-337993	R S-FIX H RVF8P01 3P 203
51	EI-300042	IC M54519P			
52	EI-323563	IC STK-3042			
53	EI-332259	IC TC4052BP			
54	EI-336717	IC TC9125BP			
55	EI-343371	IC TC9154P			
56	EI-343373	IC TC9156P			
57	EI-315381	IC TD6102P			
58	EI-327074	OSC X'TAL HC-18/U 9MHZ			
59	EM-343397	IND FL BG-136Z			
60	EO-336878	COIL DET 2 78-1049			
61	EO-336879	COIL DET 2 78-1050			
62	EO-336831	COIL IFT 119AC-15266X 10.7MC			
63	EO-344174	COIL IFT 26-5085-02 459.0KHZ			
64	EO-202216	COIL IFT 7MC-6733C 460KHZ			
65	EO-336833	COIL IFT 7MC-7736Z 460KHZ			
66	EO-202215	COIL OSC 2 7NR-6721Y 100μH			
67	EO-307786	COIL OSC 2 7NR-6722Y 580μH			

1. TUNER EQ P.C BOARD BLOCK

REF. NO.	PARTS NO.	DESCRIPTION	REF. NO.	PARTS NO.	DESCRIPTION
1-1	BA-A1004A050A	PC TUNER EQ BLK 11-R32(U)	1-FL3	ER-341654	FILTER LC LP 42W-1001
1-1	BA-A1004A050B	PC TUNER EQ BLK AA-R32 (C,A)	1-FL4	ER-337327	FILTER CE BFU459C4N 0.459MHZ (U,S,E,B)
1-1	BA-A1004A050C	PC TUNER EQ BLK AA-R32(S)	1-FL4	ER-337328	FILTER CE BFU460C4N 0.460MHZ (C,A)
1-1	BA-A1004A050D	PC TUNER EQ BLK AA-R32L (E,B)	1-FL5	ER-343354	FILTER CE SFZ459B3L 0.461MHZ (U,S,E,B)
1-IC1	EI-322248	IC LA1231N	1-FL5	ER-343355	FILTER CE SFZ460B3L 0.462MHZ (C,A)
1-IC2	EI-343349	IC LA3390	1-X1	EI-327074	OSC X'TAL HC-18/U 9MHZ
1-IC3	EI-202218	IC LA1245	1-VC1to4	EC-337772	C S-FIX H TZ032070E 2.0-7
1-IC4	EI-336717	IC TC9125BP	1-VC5	EC-330692	C S-FIX H TZ03R200E 4.2-20
1-IC5	EI-315381	IC TD6102P	1-VC6	EC-330692	C S-FIX H TZ03R200E 4.2-20 (AA-R32L)
1-IC11	EI-344764	IC M5218P-21	1-VC7	EC-330692	C S-FIX H TZ03R200E 4.2-20
1-TR1	ET-336867	TR FET 3SK73 Y	1-R21,22	ER-324337	Δ R CB H S10 FS RDS 1/4W 560J
1-TR2	ET-336869	TR 2SC2999 C,D	1-R32	ER-324185	Δ R CB H S10 FS RDS 1/4W 221J
1-TR3	ET-337744	TR 2SK212 D,E	1-R46,47	ER-324337	Δ R CB H S10 FS RDS 1/4W 560J
1-TR4	ET-618873	TR 2SC930 E,F	1-R60,61	ER-324337	Δ R CB H S10 FS RDS 1/4W 560J
1-TR5	ET-336935	TR 2SC3000 E,F	1-R100	ER-324185	Δ R CB H S10 FS RDS 1/4W 221J
1-TR6to8	ET-322775	TR 2SC536K-NP E,F,G	1-R101	ER-324184	Δ R CB H S10 FS RDS 1/4W 121J
1-TR9	ET-322778	TR 2SA608K-NP E,F,G	1-R120	ER-322787	Δ R CB H S10 FS RDS 1/4W 100J
1-TR10	ET-322775	TR 2SC536K-NP E,F,G	1-R123	ER-322421	Δ R CB H S10 FS RDS 1/4W 820J
1-TR11	ET-338410	TR 2SC2878 A,B (AA-R32L)	1-R147	ER-325114	Δ R CB H S10 FS RDS 1/4W 330J
1-TR12to15	ET-322778	TR 2SA608K-NP E,F,G (AA-R32L)	1-R215,216	ER-200941	Δ R CB H S10 FS RDS 1/4W 271J
1-TR16	ET-322775	TR 2SC536K-NP E,F,G (AA-R32L)	1-FR1	ER-318248	Δ R FUSE ERD2FC S10 1/4W 47R0G
1-TR17	ET-330588	TR FET 2SK19 O,Y (AA-R32L)	1-C56	EC-344486	C PP V F05 PP 391J 50DC (U,S,E,B)
1-TR18	ET-322775	TR 2SC536K-NP E,F,G	1-C56	EC-344478	C PP V F05 PP 561J 50DC (C,A)
1-TR19,20	ET-322775	TR 2SC536K-NP E,F,G (AA-R32L)	1-C57	EC-344486	C PP V F05 PP 391J 50DC (U,S,E,B)
1-TR21	ET-655356	Δ TR 2SD571 L,M	1-C57	EC-344478	C PP V F05 PP 561J 50DC (C,A)
1-TR22	ET-452531	Δ TR 2SD313 E,F	1-C62,63	EC-344484	C PP V F05 PP 392J 50DC
1-TR23	ET-322778	TR 2SA608K-NP E,F,G	1-C65	EC-344483	C PP V F05 PP 102J 50DC
1-TR24to26	ET-322775	TR 2SC536K-NP E,F,G	1-C71	EC-344481	C PP V F05 PP 4700G 50DC
1-TR27	ET-336937	TR FET 2SK223 E,F	1-C72	EC-344482	C PP V F05 PP 161J 50DC
1-TR28	ET-322775	TR 2SC536K-NP E,F,G (AA-R32L)			
1-D1to4	ED-336832	D VARACTOR SVC211SP			
1-D5,6	ED-301911	D SILICON H DS448			
1-D7,8	ED-337605	D VARACTOR SVC333(A) DOUBLE			
1-D9	ED-301911	D SILICON H DS448			
1-D10	ED-323057	D VARISTER MV12			
1-D12	ED-343412	D ZENER H 05Z6.2 X,Y			
1-D13	ED-343412	Δ D ZENER H 05Z6.2 X,Y			
1-D14	ED-343413	Δ D ZENER H 05Z15 X,Y			
1-D15to18	ED-336805	Δ D SILICON DS135D-KB1 200/1.0A			
1-D19	ED-301911	D SILICON H DS448			
1-D22,23	ED-301911	D SILICON H DS448			
1-D25	ED-301911	D SILICON H DS448 (AA-R32L)			
1-J1	EJ-336905	PIN J AIC-035-ACB P 4P			
1-VR1	EV-337993	R S-FIX H RVF8P01 3P 203			
1-VR2	EV-337995	R S-FIX H RVF8P01 3P 103			
1-L1	EO-336872	COIL VARI 2 TFEI-ANT-U			
1-L2	EO-336873	COIL VARI 2 TFEI-RF-1			
1-L3	EO-336938	COIL VARI 2 TFEI-RF-2			
1-L4	EO-336871	COIL VARI 2 TFEI-OSC-U			
1-L5	EO-332120	COIL FIX 2 103AK-005A 2.20μH			
1-T1	EO-336831	COIL IFT 119AC-15266X 10.7MC			
1-T2	EO-336878	COIL DET 2 78-1049			
1-T3	EO-336879	COIL DET 2 78-1050			
1-T4	EO-337598	COIL VARI 2 25A-1353-01			
1-T5	EO-337599	COIL VARI 2 25A-1354-03 (AA-R32L)			
1-T6	EO-202215	COIL OSC 2 7NR-6721Y 100μH			
1-T7	EO-307786	COIL OSC 2 7NR-6722Y 580μH (AA-R32L)			
1-T8	EO-344174	COIL IFT 26-5085-02 459.0KHZ			
1-T9	EO-202216	COIL IFT 7MC-6733C 460KHZ			
1-FL	ER-315407	FILTER CE SFE10.7MMKA 10.7MHZ			
1-FL2	ER-336804	FILTER CE SFE10.7MA8 10.7MHZ			

2. MAIN AMP P.C BOARD BLOCK

REF. NO.	PARTS NO.	DESCRIPTION
2-1	BA-A1004A020A	PC MAIN AMP BLK AA-R32 (U)
2-1	BA-A1004A020B	PC MAIN AMP BLK AA-R32 (C,A)
2-1	BA-A1004A020C	PC MAIN AMP BLK AA-R32 (S,E,B)
2-1	BA-A1004A020D	PC MAIN AMP BLK AA-R32-P (U)
2-1	BA-A1004A020E	PC MAIN AMP BLK AA-R32-P (C,A)
2-1	BA-A1004A020F	PC MAIN AMP BLK AA-R32-P (S,E,B)
2-IC1	EI-323563	IC STK-3042
2-IC2	EI-343390	Δ IC STK-1050
2-IC3	EI-336761	IC LA6458S
2-TR1	ET-305463	TR 2SA970 GR,BL
2-TR2to6	ET-307195	TR 2SC2240 GR,BL
2-TR8	ET-328440	TR 2SD863-V8 E,F
2-TR9	ET-300931	Δ TR 2SD600K E,F
2-TR10	ET-452531	TR 2SD313 E,F
2-TR11	ET-301165	Δ TR 2SB631K E,F
2-TR12	ET-307195	TR 2SC2240 GR,BL
2-D1to5	ED-301911	D SILICON H DS448
2-D6	ED-325115	D ZENER H 05Z15 L
2-D7to11	ED-301911	D SILICON H DS448
2-D12	ED-309341	D GERMA H 1K34A
2-D13	ED-344177	D ZENER H 05Z36 Y
2-D14	ED-330218	D ZENER H HZ15L 2
2-D15	ED-330219	D ZENER H HZ20L 2
2-D16,17	ED-330218	D ZENER H HZ15L 2
2-D18	ED-301911	D SILICON H DS448
2-D19	ED-346116	D ZENER H 05Z13 Y
2-D20	ED-200749	Δ D SILICON DBA60-K15 400/6.0A
2-D21	ED-301911	D SILICON H DS448
2-D22	ED-337153	D SILICON H DS446FA5 F10
2-D23	ED-346157	D ZENER H 05Z3.3 Y
2-SW1	ES-343391	SW PUSH ESB-62902 2 THROW
2-SW2	ES-343392	SW PUSH SUL222A 2 THROW
2-VR1	EV-315540	R S-FIX H D8 3P 502
2-L1	EO-337880	COIL FIX 2 202AK-018 2.20μH
2-RL1	EP-337159	RELAY SIG G4Z-2282P 2NO 24V
2-R9,11	ER-325269	Δ R CB H S10 FS RDS 1/4W 222J
2-R12,15	ER-325269	Δ R CB H S10 FS RDS 1/4W 222J
2-R21	ER-337773	Δ R OMF H S15 FS 1W 222J
2-R25,26	ER-308875	Δ R CB H S15 FS RDS 1/2W 100J
2-R33	ER-333067	Δ R OMF H S20 FS 2W 821J
2-R34	ER-333044	Δ R OMF H S20 FS 2W 152J
2-R35	ER-308875	Δ R CB H S15 FS RDS 1/2W 100J
2-R39,40	ER-325269	Δ R CB H S10 FS RDS 1/4W 222J
2-R41	ER-323075	Δ R CB H SNP FS RDS 1/4W 472J
2-R42	ER-323074	Δ R CB H S10 FS RDS 1/4W 102J
2-R43	ER-333598	Δ R CB H S15 FS RDS 1/2W 102J
2-R47	ER-306127	Δ R CB H S15 FS RDS 1/2W 681J
2-R51	ER-322787	Δ R CB H S10 FS RDS 1/4W 100J
2-FR1,2	ER-318248	Δ R FUSE ERD2FC S10 1/4W 47R0G
2-FR3,4	ER-337756	Δ R FUSE ERD2FC S10 1/4W 4700G
2-FR5,6	ER-328519	Δ R FUSE ERD2FC S10 1/4W 68R0G
2-C9	EC-343855	C EC V F05 NP SM R22M 50.0DC
2-C10	EC-338380	C EC V T05 NP SM 2R2M 50.0DC
2-C16	EC-337151	C EC V CUT NP 04D 221M 6.3DC
2-C22,23	EC-320548	C CE V F 103Z 250AC
2-C28,29	EC-343393	C EC V CUT SM 103M 50.0DC

REF. NO.	PARTS NO.	DESCRIPTION
2-J1	EJ-343395	PHONE J HLJ0608-023 6.3 (AA-R32/L)
2-J1	EJ-343396	PHONE J 3P HLJ0608-024 6.3 (AA-R32-P/L-P)
2-R49,50	ER-313699	Δ R OMF H FS 2W 221J
2-IC1,2	EI-315799	IC HA12019

3. CONTROL P.C BOARD BLOCK

REF. NO.	PARTS NO.	DESCRIPTION
3-1	BA-A1004A060A	PC CONTROL BLK AA-R32(U)
3-1	BA-A1004A060B	PC CONTROL BLK AA-R32(C,A)
3-1	BA-A1004A060C	PC CONTROL BLK AA-R32(S)
3-1	BA-A1004A060D	PC CONTROL BLK AA-R32L (E,B)
3-IC1	EI-343374	IC AA-100
3-IC2	EI-337600	IC AT600
3-IC3to6	EI-337013	IC LB1290
3-IC7,8	EI-338171	IC LC4069UB
3-IC9,10	EI-300042	IC M54519P
3-IC11to13	EI-343373	IC TC9156P
3-IC14	EI-344490	IC LA6458D
3-IC15to17	EI-332259	IC TC4052BP
3-TR1,2	ET-322775	TR 2SC536K-NP E,F,G
3-D1,2	ED-343410	D ZENER H HZ6L A1
3-D11to22	ED-337153	D SILICON H DS446FA5 F10
3-D23,24	ED-301911	D SILICON H DS448 (AA-R32L)
3-D25	ED-337153	D SILICON H DS446FA5 F10
3-D26	ED-323354	D ZENER H 05Z6.2 X
3-D27	ED-301911	D SILICON H DS448 (AA-R32L)
3-D28	ED-301911	D SILICON H DS448 (U,C,A)
3-D29	ED-301911	D SILICON H DS448 (C,A)
3-D30	ED-301911	D SILICON H DS448
3-I15,16	EJ-343401	PIN J AJC-035-ADB P 4P
3-SW1	ES-343398	SW SLIDE HSW0690-400 2-02-02N (U)
3-SW2	ES-343399	SW SLIDE HSW0690-410 1-01-02N (U,C,A)
3-SW3	ES-343400	SW TACT EVQ-QHR12K
3-T1,2	EO-336833	COIL IFT 7MC-7736Z 160 KHZ
3-SR1	ER-343409	R COMP EXB-P87103M
3-SC2	EC-344480	C COMP 05-0009
3-C50	EC-336882	C DOUBLE LAYER 104 5.5DC
3-C60	EC-344482	C PP V F05 PP 161J 500C (U)

4. KEY BOARD (1) P.C BOARD BLOCK

REF. NO.	PARTS NO.	DESCRIPTION
4-SW1to11	ES-336780	SW TACT KHH10902
4-SW13to16	ES-336780	SW TACT KHH10902
4-IND1	EM-343397	IND FL BG-136Z

5. KEY BAORD (2) P.C BOARD BLOCK

REF. NO.	PARTS NO.	DESCRIPTION
5-SW1to8	ES-336780	SW TACT KHH10902
5-SW11to20	ES-336780	SW TACT KHH10902

6. POWER P.C BOARD BLOCK

REF. NO.	PARTS NO.	DESCRIPTION
6-SW1	ES-343688	Δ SW PUSH ESB-90271S 01-1EBV(U,S,E,B)
6-SW1	ES-343689	Δ SW PUSH ESB-90161T 01-UC (C,A)
6-C1	EC-320548	Δ C CE V F 103Z 250AC (U)
6-C1	EC-314688	Δ C CE V FZ 103P 123AC (C,A)
6-C1	EC-338496	Δ C CE V FZ 472P 404AC (S,E,B)

ASSEMBLY BLOCK

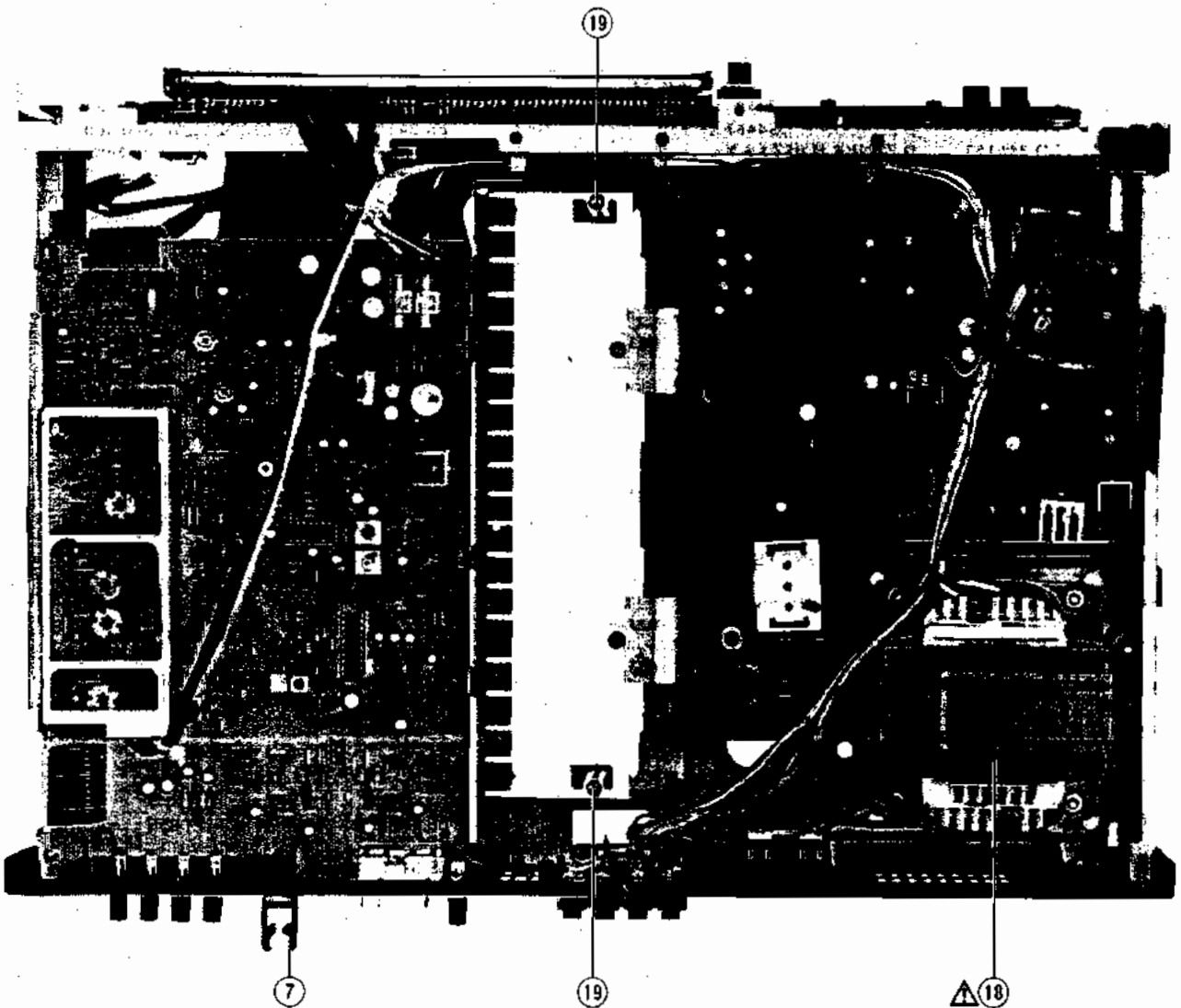
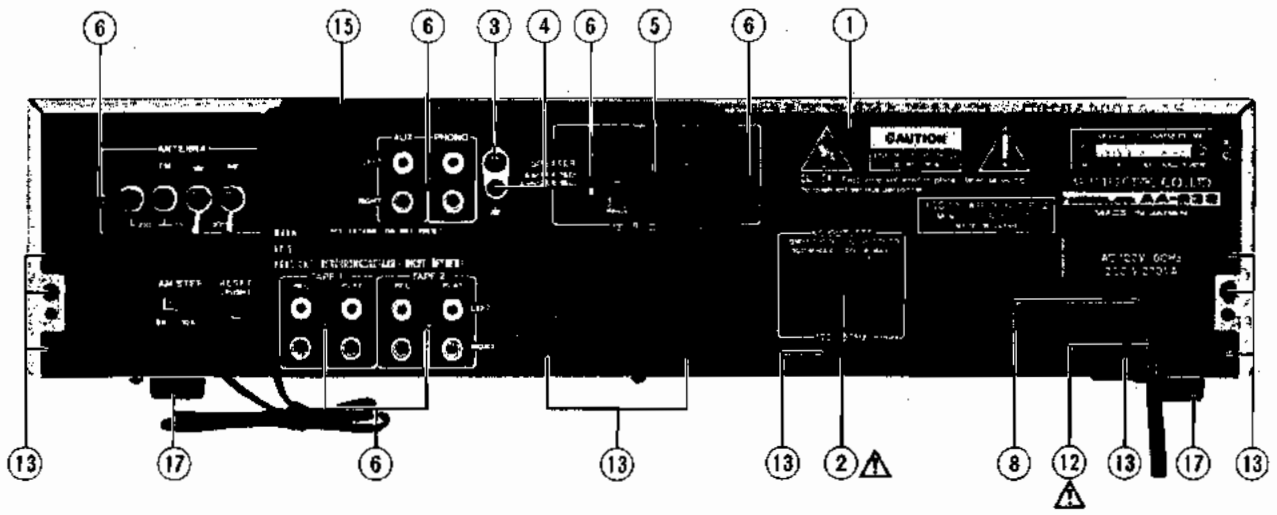

7. ASSEMBLY BLOCK

REF. NO.	PARTS NO.	DESCRIPTION
7-1	SP-342791A	PANEL REAR AA-R32 (U)
7-1x	SP-342791B	PANEL REAR AA-R32 (C,A)
7-1x	SP-342791D	PANEL REAR AA-R32 (S)
7-1x	SP-342791E	PANEL REAR AA-R32L (E)
7-1x	SP-342791F	PANEL REAR AA-R32L (B)
7-2	EJ-343362	△ SOCKET OUTLET S2T732T174 JUC (U,C,A)
7-3	EJ-329610	TERMINAL W/SCREW UB-0067 L 1P
7-4	ZS-319460	T2BR30x06STL BZN PROJECTION
7-5	EJ-343389	TERMINAL PUSH S-Q2780#01 S 8P
7-6	ZS-522865	T2BR30x12STL BNI
7-7	ER-322739	R CB H T26 RDS 1/4W 204J
7-8	SZ-631945	STRAIN RELIEF SR-4N-4
7-9x	ES-343367	△ SW SLIDE HSW 0700-30 1-01-02N (U)
7-10x	ZS-463353	T2BR30x08STL BNI
7-11x	ER-233583	△ R SD 1/2W 225K (C,A)
7-12	EW-306428	△ AC CORD 2 CORES KP-205A, VFF J (U)
7-12x	EW-343363	△ AC CORD 2 CORES KP-8, SPT-2 UC (C)
7-12x	EW-328245	△ AC CORD 2 CORES KP-8, SPT-1 105°C UC (A)
7-12x	EW-336924	△ AC CORD 2 CORES KP-560, LTSA-2F (S)
7-12x	EW-313882	△ AC CORD 2 CORES KP-419C, LTCE-2F (E)
7-12x	EW-347025	△ AC CORD LTBS-2F 42/0.15x2 (B)
7-13	ZS-319460	T2BR30x06STL BZN PROJECTION
7-14x	ZS-530673	ROLLER SCREW (A)
7-15	EE-337976	ANT LOOP LA-200A
7-16x	EF-326639	△ FUSE TSC A 250V 3.15A (U)(F1)
7-16x	EF-326639	△ FUSE TSC A 250V 3.15A (U)(F2)
7-16x	EF-309390	△ FUSE TSC 125V 0.50A (C,A)(F6,7)
7-16x	EF-346139	△ FUSE TSC 125V 5A (C,A)(F1)
7-16x	EF-300599	△ FUSE FST3100 T 250V 0.40A (S,E,B)(F6,7)
7-17	SA-332850	ROUND FOOT
7-18	BT-343384	△ TRANS POWER AA-R32T-70 (U)
7-18x	BT-343385	△ TRANS POWER AA-R32T-30 (C)
7-18x	BT-343386	△ TRANS POWER AA-R32T-20 (A)
7-18x	BT-343388	△ TRANS POWER AA-R32T-50 (S,B)
7-18x	BT-343387	TRANS POWER AA-R32T-40 (E)
7-19	ZS-342792B	SCREW HEAT-SINK (B)

FINAL ASSEMBLY BLOCK

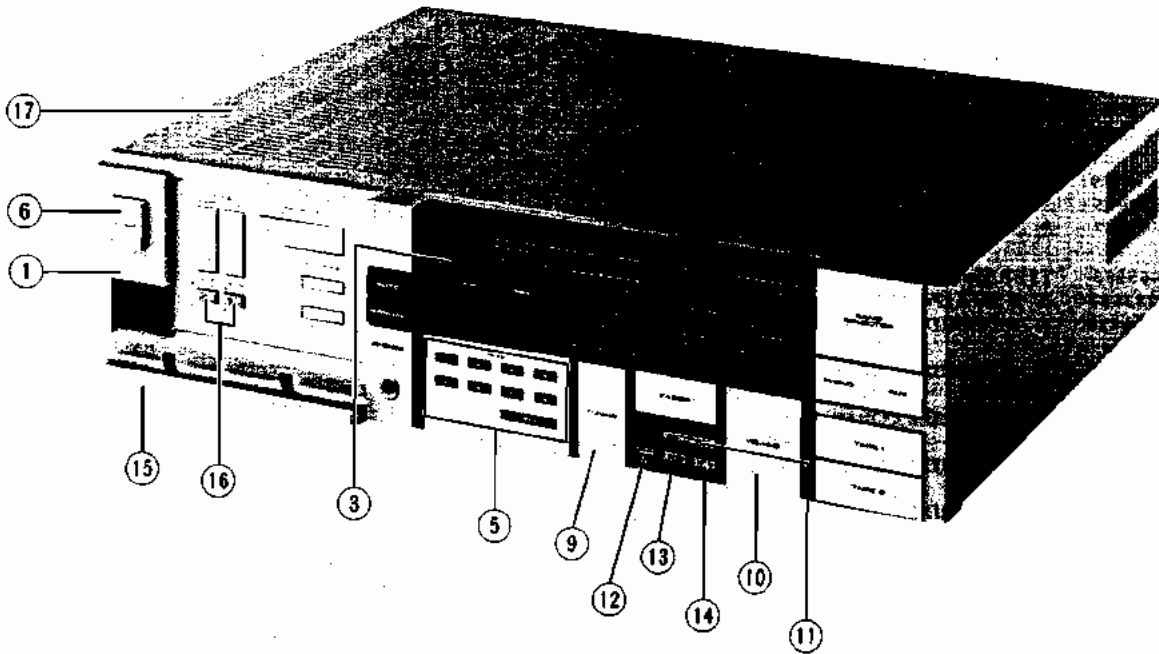

8. FINAL ASSEMBLY BLOCK

REF. NO.	PARTS NO.	DESCRIPTION
8-1	BD-A1004A080A	PANEL FRONT BLK AA-R32
8-1x	BD-A1004A080B	PANEL FRONT BLK AA-R32-P
8-2x	BD-B342799C	PANEL FRONT (B)
8-2x	BD-B342799D	PANEL FRONT (B)-P PART
8-3	SZ-342812	WINDOW FRONT
8-4x	ZS-310343	PLX PAN30x06STL CMT
8-5	SK-B342817	KNOB OPERATION PART
8-5x	SK-B342817B	KNOB OPERATION-P PART
8-6	SK-342820A	KNOB POWER
8-6x	SK-342820B	KNOB POWER-P
8-7x	ZG-322189	SPRING (B)
8-8x	ZS-325503	PLX PAN30x12STL CMT
8-9	SK-B342806A	KNOB CAP (C-1) PART
8-9x	SK-B342806B	KNOB CAP (C-1)-P PART
8-10	SK-B342809A	KNOB CAP (E) PART
8-10x	SK-B342809B	KNOB CAP (E)-P PART
8-11	SK-342815	KNOB DEFEAT
8-12	SK-342816A	KNOB TONE (A)
8-13	SK-342816B	KNOB TONE (B)
8-14	SK-342816C	KNOB TONE (C)
8-15	SP-342822A	PANEL DOOR AA-R32
8-15x	SP-342822B	PANEL DOOR AA-R32-P
8-15x	SP-342822C	PANEL DOOR AA-R32L
8-15x	SP-342822D	PANEL DOOR AA-R32L-P
8-16	SK-342819A	KNBO PUSH
8-16x	SK-342819B	KNOB PUSH-P
8-17	SP-342823A	COVER UPPER
8-17x	SP-342823B	COVER UPPER-P
8-18	ZS-308846	T2BR30x08STL BZN PROJECTION
8-19x	SZ-342794	GUIDE (L)
8-20x	SZ-342795	GUIDE (R)
8-21x	SZ-342796	SLIDER

III. AA-R42

RECOMMENDED SPARE PARTS

Because, if the parts listed below are on hand, almost any repair can be accomplished, we suggest that you stock these Recommended Spare Parts Items.

NO.	PARTS NO.	DESCRIPTION	NO.	PARTS NO.	DESCRIPTION
1	ED-346133	D ZENER 05Z3.9 Y	70	EO-336833	COIL IFT 7MC-7736Z 460KHZ
2	BT-343404	TRANS POWER AA-R42T-20	71	EO-202215	COIL OSC 2 7NR-6721Y 100μH
3	BT-343403	TRANS POWER AA-R42T-30	72	EO-336872	COIL VARI 2 TFEI-ANT-U
4	BT-343405	TRANS POWER AA-R42T-50	73	EO-336871	COIL VARI 2 TFEI-OSC-U
5	BT-343402	TRANS POWER AA-R42T-70	74	EO-336873	COIL VARI 2 TFEI-RF-1
6	EC-320548	Δ C CE V F 103Z 250AC (U)	75	EO-336938	COIL VARI 2 TFEI-RF-2
7	EC-314688	Δ C CE V FZ 103P 125AC (C,A)	76	EO-337598	COIL VARI 2 25A-1353-01
8	EC-338496	Δ C CE V FZ 472P 400AC (S)	77	EP-337159	RELAY SIG G4Z-2282P 2NO 24V
9	EC-344480	C COMP 05-0009	78	EP-337416	RELAY SIGNAL G2V-282P-NL 2TR 12V
10	EC-336882	C DOUBLE LAYER 104 5.5DC	79	ER-337327	FILTER CE BFU459C4N 0.459MHZ
11	EC-330692	C S-FIX H TZ03R200E 4.2-20	80	ER-337328	FILTER CE BFU460C4N 0.46MHZ
12	EC-337772	C S-FIX H TZ03Z070E 2.0-7	81	ER-336804	FILTER CE SFE10.7MA8 10.7MHZ
13	ED-330320	Δ D SILICON DBA10C 200/1.0A	82	ER-343354	FILTER CE SFZ459B3L 0.461MHZ
14	ED-200749	Δ D SILICON DBA60-K15 400/6.0A	83	ER-343355	FILTER CE SFZ460B3L 0.462MHZ
15	ED-336805	Δ D SILICON DS135D-KB1 200/1.0A	84	ER-341654	FILTER LC LP 42W-1001
16	ED-330218	Δ D ZENER H HZ15L 2	85	ER-315407	FILTER CE SFE10.7MMKA 10.7MHZ
17	ED-343421	Δ D ZENER H HZ16L 2	86	ES-343689	Δ SW PUSH ESB-90164T 01-1UC (C,A)
18	ED-343413	Δ D ZENER H 05Z15 X,Y	87	ES-343688	Δ SW PUSH ESB-90279S 01-1EBV (U,S)
19	ED-343412	Δ D ZENER H 05Z6.2 X,Y	88	ES-343407	SW PUSH ESB-62901 3 THROW
20	ED-309341	D GERMA H IK34A	89	ES-342910	SW PUSH SUL222S 2 THROW
21	ED-338119	D SILICON H DS446BT T26	90	ES-343364	SW SELECTA 0240#01 01-4
22	ED-337153	D SILICON H DS446FA5 F10	91	ES-343398	SW SLIDE HSW0690-400 2-02-02N
23	ED-200469	D SILICON H DS448 FA5 F10	92	ES-343399	SW SLIDE HSW0690-410 1-01-02N
24	ED-330207	D SILICON H DS448BT T26	93	ES-343400	SW TACT EVQ-QHR12K
25	ED-200468	D SILICON V DS448-VB6	94	ES-336780	SW TACT KHH10902
26	ED-336832	D VARACTOR SVC211SP	95	ET-301165	Δ TR 2SB631K E,F
27	ED-337605	D VARACTOR SVC333 (A) DOUBLE	96	ET-452531	Δ TR 2SD313 E,F
28	ED-323057	D VARISTOR MV12	97	ET-655356	Δ TR 2SD571 L,M
29	ED-343410	D ZENER H HZ6L A1	98	ET-300931	Δ TR 2SD600K E,F
30	ED-324195	D ZENER H 05Z13 U	99	ET-336937	TR FET 2SK223 E,F
31	ED-343422	D ZENER H 05Z18 Y	100	ET-343414	TR FET 2SK270 GR,BL,V
32	ED-343415	D ZENER H 05Z36 X	101	ET-336867	TR FET 3SK73 Y
33	ED-323354	D ZENER H 05Z6.2	102	ET-323529	TR 2SA608K-NP E,F
34	EE-337976	ANT LOOP LA-200A	103	ET-322778	TR 2SA608K-NP E,F,G
35	EF-300601	Δ FUSE FST3100 T 250V 0.50A (S) F6,7	104	ET-305463	TR 2SA970 GR,BL
36	EF-593706	Δ FUSE SEMKO T 250V 0.50A (S) F4	105	ET-307195	TR 2SC2240 GR,BL
37	EF-593706	Δ FUSE SEMKO T 250V 0.50A (S) F3	106	ET-336869	TR 2SC2999 C,D
38	EF-691007	Δ FUSE SEMKO T 250V 3.15A (S) F1	107	ET-336935	TR 2SC3000 E,F
39	EF-326639	Δ FUSE TSC A 250V 3.15A (U) F1	108	ET-316171	TR 2SC536K-NP E,F
40	EF-309390	Δ FUSE TSC 125V 0.50A (C) F6,7	109	ET-322775	TR 2SC536K-NP E,F,G
41	EF-305703	Δ FUSE TSC 125V 0.63A (C) F4	110	ET-618873	TR 2SC930 E,F
42	EF-305703	Δ FUSE TSC 125V 0.63A (C) F3	111	ET-328440	TR 2SD863-V8 E,F
43	EF-346115	Δ FUSE TSC 125V 6.30A (C) F1	112	ET-337744	TR 2SK212 D,E
44	EI-343406	Δ IC STK-1070	113	EV-315540	R S-FIX H D8 3P 502
45	EI-343374	IC AA-100	114	EV-337995	R S-FIX H RVF8P01 3P 103
46	EI-337600	IC AT600	115	EV-337993	R S-FIX H RVF8P01 3P 203
47	EI-315799	IC HA12019			
48	EI-322248	IC LA1231N			
49	EI-202218	IC LA1245			
50	EI-343349	IC LA3390			
51	EI-344490	IC LA6458D			
52	EI-336761	IC LA6458S			
53	EI-337013	IC LB1290			
54	EI-338171	IC LC4069UB			
55	EI-300042	IC M54519P			
56	EI-213390	IC NJM4558D			
57	EI-326595	IC STK3062			
58	EI-332259	IC TC4052BP			
59	EI-336717	IC TC9125BP			
60	EI-343371	IC TC9154P			
61	EI-343373	IC TC9156P			
62	EI-315381	IC TD6102P			
63	EI-327074	OSC X'TAL HC-18/U 9MHZ			
64	EM-343397	IND FL BG-136Z			
65	EO-336878	COIL DET 2 78-1049			
66	EO-336879	COIL DET 2 78-1050			
67	EO-336831	COIL IFT 119AC-15266X 10.7MC			
68	EO-344174	COIL IFT 26-5085-02 459.0KHZ			
69	EO-202216	COIL IFT 7MC6733C 460KHZ			

1. TUNER EQ P.C BOARD BLOCK

REF. NO.	PARTS NO.	DESCRIPTION	REF. NO.	PARTS NO.	DESCRIPTION
1-1	BA-A1005A040A	PC TUNER/EQ BLK AA-R42 (U)	1-FR2	ER-200747	△ R FUSE ERD2FC 1/4W
1-1	BA-A1005A040B	PC TUNER/EQ BLK AA-R42 (C,A)	1-R21,22	ER-324337	△ R CB H S10 FS RDS 1/4W 68R0G
1-1	BA-A1005A040C	PC TUNER/EQ BLK AA-R42 (S)	1-R32	ER-324185	△ R CB H S10 FS RDS 1/4W 560J
1-IC1	EI-322248	IC LA1231N	1-R46,47	ER-324337	△ R CB H S10 FS RDS 1/4W 560J
1-IC2	EI-343349	IC LA3390	1-R60,61	ER-324337	△ R CB H S10 FS RDS 1/4W 560J
1-IC3	EI-202218	IC LA1245	1-R100	ER-324185	△ R CB H S10 FS RDS 1/4W 221J
1-IC4	EI-336717	IC TC9125BP	1-R101	ER-324184	△ R CB H S10 FS RDS 1/4W 121J
1-IC5	EI-315381	IC TD6102P	1-R120	ER-322787	△ R CB H S10 FS RDS 1/4W 100J
1-IC11	EI-213390	IC NJM4558D	1-R123	ER-322421	△ R CB H S10 FS RDS 1/4W 820J
1-TR1	ET-336867	TR FET 3SK73 Y	1-R147	ER-325114	△ R CB H S10 FS RDS 1/4W 330J
1-TR2	ET-336869	TR 2SC2999 C,D	1-R215,216	ER-327710	△ R CB H S10 FS RDS 1/4W 151J
1-TR3	ET-337744	TR 2SK212 D,E	1-C56,57	EC-344486	C PP V F05 PP 391J 50DC (U,S)
1-TR4	ET-618873	TR 2SC930 E,F	1-C56,57	EC-344478	C PP V F05 PP 561J 50DC (C,A)
1-TR5	ET-336935	TR 2SC3000 E,F	1-C62,63	EC-344484	C PP V F05 PP 392J 50DC
1-TR6to8	ET-322775	TR 2SC536K-NP E,F,G	1-C65	EC-344483	C PP V F05 PP 102J 50DC
1-TR9	ET-322778	TR 2SA608K-NP E,F,G	1-C71	EC-344481	C PP V F05 PP 4700G 50DC
1-TR10,18	ET-322775	TR 2SC536K-NP E,F,G	1-C102	EC-323847	C EC V CUT SM 102M 35.0DC
1-TR21	ET-655356	△ TR 2SD571 L,M	1-TM1	EJ-309941	TERMINAL W/SCREW UB-1059 P 4P
1-TR22	ET-452531	△ TR 2SD313 E,F			
1-TR23	ET-322778	TR 2SA608K-NP E,F,G			
1-TR24to26	ET-322775	TR 2SC536K-NP E,F,G			
1-TR27	ET-336937	TR FET 2SK223 E,F			
1-TR35	ET-343414	TR FET 2SK270 GR,BL,V			
1-D1to4	ED-336832	D VARACTOR SVC211SP			
1-D5,6	ED-301911	D SILICON H DS448			
1-D7,8	ED-337605	D VARACTOR SVC333 (A) DOUBLE			
1-D9	ED-301911	D SILICON H DS448			
1-D10	ED-323057	D VARISTER MV12			
1-D12	ED-343412	D ZENER H 05Z6.2 X,Y			
1-D13	ED-343412	△ D ZENER H 05Z6.2 X,Y			
1-D14	ED-343413	△ D ZENER H 05Z15 X,Y			
1-D15to18	ED-336805	△ D SILICON DS135D-KB1 200/1.0A			
1-D19,20	ED-301911	D SILICON H DS448			
1-D22,23	ED-301911	D SILICON H DS448			
1-J1	EJ-336905	PIN J AJC-035-ACB P 4P			
1-VR1	EV-337993	R S-FIX H RVF8P01 3P 203			
1-VR2	EV-337995	R S-FIX H RVF8P01 3P 103			
1-L1	EO-336872	COIL VARI 2 TFEI-ANT-U			
1-L2	EO-336873	COIL VARI 2 TFEI-RF-1			
1-L3	EO-336938	COIL VARI 2 TFEI-RF-2			
1-L4	EO-336871	COIL VARI 2 TFEI-OSC-U			
1-L5	EO-332120	COIL FIX 2 103AK-005A 2.20μH			
1-T1	EO-336831	COIL IFT 119AC-15266X 10.7MC			
1-T2	EO-336878	COIL DET 2 78-1049			
1-T3	EO-336879	COIL DET 2 78-1050			
1-T4	EO-337598	COIL VARI 2 25A-1353-01			
1-T6	EO-202215	COIL OSC 2 7NR-6721Y 100μH			
1-T8	EO-344174	COIL IFT 26-5085-02 459.0KHZ			
1-T9	EO-202216	COIL IFT 7MC-6733C 460KHZ			
1-FL1	ER-315407	FILTER CE SFE10.7MMKA 10.7MHZ			
1-FL2	ER-336804	FILTER CE SFE10.7MA8 10.7MHZ			
1-FL3	ER-341654	FILTER LC LP 42W-1001			
1-FL4	ER-337327	FILTER CE BFU459C4N 0.459MHZ (U,S)			
1-FL4	ER-337328	FILTER CE BFU460C4N 0.46MHZ (C,A)			
1-FL5	ER-343354	FILTER CE SFZ459B3L 0.461MHZ (U,S)			
1-FL5	ER-343355	FILTER CE SFZ460B3L 0.462MHZ (C,A)			
1-X1	EI-327074	OSC X TAL HC-18/U 9MHZ			
1-RL1	EP-337416	RELAY SIGNAL G2V-282P-NL 2TR 12V			
1-VC1to4	EC-337772	C S-FIX H TZ032070E 2.0-7			
1-VC5	EC-330692	C S-FIX H TZ03R200E 4.2-20			
1-VC7	EC-330692	C S-FIX H TZ03R200E 4.2-20			
1-FR1	ER-318248	△ R FUSE ERD2FC S10 1/4W 47R0G			

2. MAIN AMP P.C BOARD BLOCK

REF. NO.	PARTS NO.	DESCRIPTION
2-1	BA-A1005A020A	PC MAIN AMP BLK AA-R42 (U)
2-1	BA-A1005A020B	PC MAIN AMP BLK AA-R42 (C,A)
2-1	BA-A1005A020C	PC MAIN AMP BLK AA-R42 (S)
2-1	BA-A1005A020D	PC MAIN AMP BLK AA-R42-P (U)
2-1	BA-A1005A020E	PC MAIN AMP BLK AA-R42-P (C,A)
2-1	BA-A1005A020F	PC MAIN AMP BLK AA-R42-P(S)
2-IC1	EI-326595	IC STK3062
2-IC2	EI-343406	Δ IC STK-1070
2-IC3	EI-336761	IC LA6458S
2-TR1	ET-343414	TR FET 2SK270 GR,BL,V
2-TR2	ET-305463	TR 2SA970 GR,BL
2-TR3to5	ET-307195	TR 2SC2240 GR,BL
2-TR6,7	ET-316171	TR 2SC536K-NP E,F
2-TR9	ET-328440	TR 2SD863-V8 E,F
2-TR10	ET-300931	Δ TR 2SD600K E,F
2-TR11	ET-452531	Δ TR 2SD313 E,F
2-TR12	ET-301165	Δ TR 2SB631K E,F
2-TR13	ET-307195	TR 2SC2240 GR,BL
2-D1to3	ED-337153	D SILICON H DS446FA5 F10
2-D5to7	ED-337153	D SILICON H DS446FA5 F10
2-D8	ED-343422	D ZENER H 05Z18 Y
2-D9,10	ED-337153	D SILICON H DS446FA5 F10
2-D11	ED-343415	D ZENER H 05Z36 X
2-D12	ED-330218	D ZENER H HZ15L 2
2-D13	ED-343421	Δ D ZENER H HZ16L 2
2-D14	ED-330218	Δ D ZENER H HZ15L 2
2-17,18	ED-301911	D SILICON H DS448
2-D19	ED-309341	D GERMA H 1K34A
2-D20	ED-337153	D SILICON H DS446FA5 F10
2-D21	ED-330320	Δ D SILICON DBA10C 200/1.0A
2-D22	ED-200749	Δ D SILICON DBA60-K15 400/6.0A
2-D23	ED-324195	D ZENER H 05Z13 U
2-D24	ED-337153	D SILICON H DS446FA5 F10
1-D25	ED-346133	D ZENER H 05Z3.9 Y
2-SW1	ES-342910	SW PUSH SUL222S 2 THROW
2-SW2	ES-343407	SW PUSH ESB-62901 3 THROW
2-L1	EO-332116	COIL FIX 2 103AK-006A 2.2μH
2-RL1	EP-337159	RELAY SIG G4Z-2282P 2NO 24V
2-VR1	EV-315540	R S-FIX H D8 3P 502
2-FR1to3	ER-326169	Δ R FUSE ERD2FC F10 1/4W 22R0G
2-R16	ER-333654	Δ R CB H S15 FS RDS 1/2W 332J
2-R29,30	ER-337754	Δ R OMF H S15 FS 1W 100J
2-R36	ER-337755	Δ R OMF H S20 FS 2W 222J
2-R37	ER-338593	Δ R OMF H S20 FS 2W 821J
2-R38	ER-308875	Δ R CB H S15 FS RDS 1/2W 100J
2-R39,49	ER-325269	Δ R CB H S10 FS RDS 1/4W 222J
2-R45	ER-320538	Δ R OMF H S15 FS 1W 391J
2-R46	ER-333426	Δ R CB H S10 FS RDS 1/4W 622J
2-R47	ER-337794	Δ R MF H S15 FS 1W 821J 102J
2-R51	ER-333598	Δ R CB H S15 FS RDS 1/2W 622J
2-C10,11	EC-343730	C EC V T05 NP SM 100M 16.0DC
2-C12	EC-343855	Δ C EC V F05 NP SM R22M 50.0DC
2-C13	EC-334013	C EC V CUT NP SM 331M 6.3DC
2-C30,31	EC-343424	C EC V 123M/56DC
2-J1	EJ-343395	PHONE J HLJ0608-023 6.3 (AA-R42)
2-J1	EJ-343396	PHONE J 3P HLJ0608-024 6.3 (AA-R42-P)
2-R1	ER-343423	Δ R MF H FS 2W 331J
2-IC1,2	EI-315799	IC HA12019

3. CONTROL P.C BOARD BLOCK

REF. NO.	PARTS NO.	DESCRIPTION
3-1	BA-A1005A050A	PC CONTROL BLK AA-R42 (U)
3-1	BA-A1005A050B	PC CONTROL BLK AA-R42(C,A)
3-1	BA-A1005A050C	PC CONTROL BLK AA-R42 (S)
3-IC1	EI-343374	IC AA-100
3-IC2	EI-337600	IC AT600
3-IC3to6	EI-337013	IC LB1290
3-IC7,8	EI-338171	IC LC4069UB
3-IC9to13	EI-343373	IC TC9156P
3-IC14	EI-344490	IC LA6458D
3-IC15to17	EI-332259	IC TC4052BP
3-TR1to3	ET-322775	TR 2SC536K-NP E,F,G
3-TR4	ET-323529	TR 2SA608K-NP E,F
3-D1,2	ED-343410	D ZENER H HZ6L A1
3-D11to22	ED-337153	D SILICON H DS446FA5 F10
3-D25	ED-337153	D SILICON H DS446FA5 F10
3-D26	ED-323354	D ZENER H 05Z6.2 X
3-D28,29	ED-200469	D SILICON H DS448 FA5 F10
3-D31to34	ED-301911	D SILICON H DS448
3-J15,16	EJ-343401	PIN J AJC-035-ADB P 4P
3-SW1	ES-343398	SW SLIDE HSW0690-400 2-02-02N (U)
3-SW2	ES-343399	SW SLIDE HSW0690-410 1-01-02N(U,C,A)
3-SW3	ES-343400	SW TACT EVQ-QHR12K
3-T1,2	EO-336833	COIL IFT 7MC-7736Z 460KHZ
3-SR1	ER-343409	R COMP EXB-P87103M
3-SC2	EC-344480	C COMP 05-0009
3-C50	EC-336882	C DOUBLE LAYER 104 5.5DC
3-C60	EC-344482	C PP V F05 PP 161J 50DC (U)

4. POWER P.C BOARD BLOCK

REF. NO.	PARTS NO.	DESCRIPTION
4-SW1	ES-343688	Δ SW PUSH ESB-90279S 01-1EBV (U,S)
4-SW1	ES-343689	Δ SW PUSH ESB-90164T 01-1U0 (C,A)
4-C1	EC-320548	Δ C CE V F 103Z 250AC(U)
4-C1	EC-314688	Δ C CE V FZ 103P 125AC (C,A)
4-C1	EC-338496	Δ C CE V FZ 472P 400AC

5. KEY BOARD (1) P.C BOARD BLOCK

REF. NO.	PARTS NO.	DESCRIPTION
5-SW1to16	ES-336780	SW TACT KHH10902
5-1	EM-343397	IND FL BG-136Z

6. KEY BOARD (2) P.C BOARD BLOCK

REF. NO.	PARTS NO.	DESCRIPTION
6-SW1to20	ES-336780	SW TACT KHH10902

ASSEMBLY BLOCK

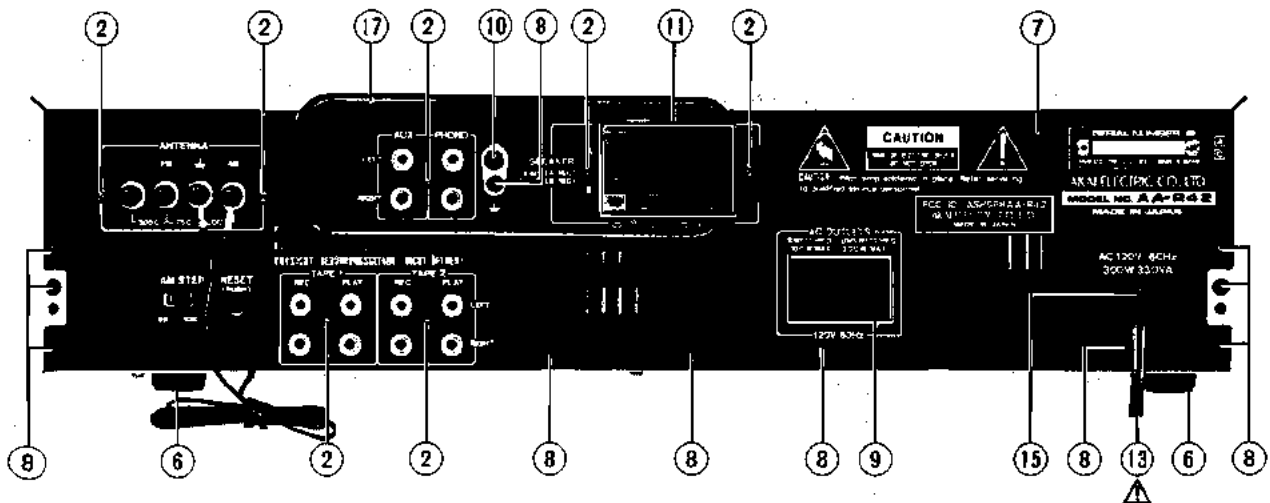
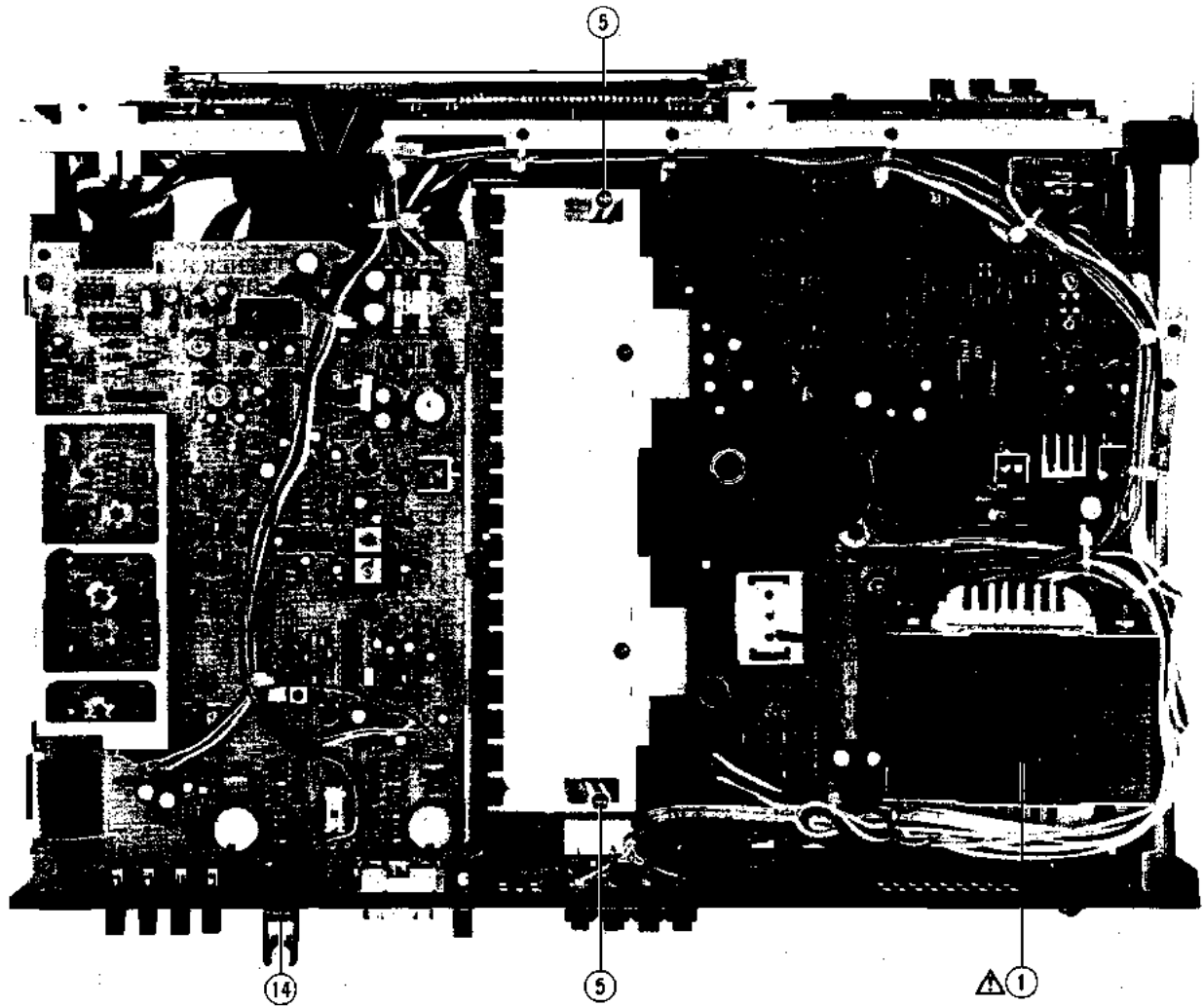

7. ASSEMBLY BLOCK

REF. NO.	PARTS NO.	DESCRIPTION
7-1	BT-343402	Δ TRANS POWER AA-R42T-70 (U)
7-1x	BT-343403	Δ TRANS POWER AA-R42T-30 (C)
7-1x	BT-343404	Δ TRANS POWER AA-R42T-20 (A)
7-1x	BT-343405	Δ TRANS POWER AA-R42T-50 (S)
7-2	ZS-522865	T2BR30x12STL BNI
7-3x	ZS-530673	ROLLER SCREW (A)
7-4x	ZS-498273	T2BR30x08STL CMT PW080
7-5	ZS-342792A	SCREW HEAT-SINK (A)
7-6	SA-332850	ROUND FOOT
7-7	SP-342791G	PANEL REAR AA-R42 (U)
7-7x	SP-342791H	PANEL REAR AA-R42 (C,A)
7-7x	SP-342791K	PANEL REAR AA-R42 (S)
7-8	ZS-319460	T2BR30x06STL BZN PROJECTION
7-9	EJ-343362	Δ SOCKET OUTLET S2T732T174 JUC (U,C,A)
7-10	EJ-329610	TERMINAL W/SCREW UB-0067 L 1P
7-11	EJ-343389	TERMINAL PUSH S-Q2780#01 S 8P
7-12x	ER-233583	Δ R SD 1/2W 225K (C,A)
7-13	EW-306428	Δ AC CORD 2 CORES KP-205A, VFF J (U)
7-13x	EW-343363	Δ AC CORD 2 CORES KP-8, SPT-2 UC (C)
7-13x	EW-328245	Δ AC CORD 2 CORES KP-8, SPT-1 105°C UC (A)
7-13x	EW-336924	Δ AC CORD 2 CORES KP-560, LTSA-2F (S)
7-14	SZ-332739	HOLDER ANTENNA
7-15	SZ-631945	STRAIN RELIEF SR-4N-4
7-16x	ZS-463353	T2BR30x08STL BNI
7-17	EE-337976	ANT LOOP LA-200A
7-18x	EF-326639	Δ FUSE TSC A 250V 3.15A (U) (F1,2)
7-18x	EF-346115	Δ FUSE TSC 125V 6.30A (C) (F1)
7-18x	EF-305703	Δ FUSE TSC 125V 0.63A (C) (F3,4)
7-18x	EF-309390	Δ FUSE TSC 125V 0.50A (C) (F6,7)
7-18x	EF-346115	Δ FUSE TSC 125V 6.30A (A) (F1)
7-18x	EF-305703	Δ FUSE TSC 125V 0.63A (A) (F3,4)
7-18x	EF-309390	Δ FUSE TSC 125V 0.50A (A) (F6,7)
7-18x	EF-691007	Δ FUSE SEMKO T 250V 3.15A (S)(F1)
7-18x	EF-593706	Δ FUSE SEMKO T 250V 0.50A (S)(F3,4)
7-18x	EF-300601	Δ FUSE FST3100 T 250V 0.50A (S)(F6,7)

FINAL ASSEMBLY BLOCK

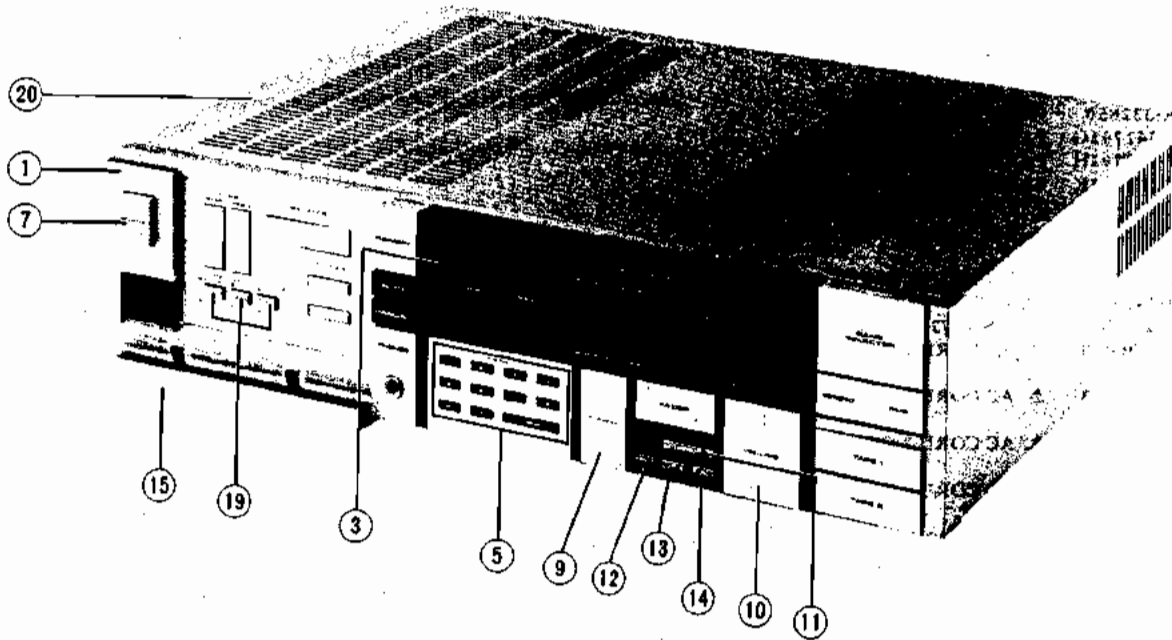

8. FINAL ASSEMBLY BLOCK

REF. NO.	PARTS NO.	DESCRIPTION
8-1	BD-A1005A070A	PANEL FRONT BLK AA-R42
8-1x	BD-A1005A070B	PANEL FRONT BLK AA-R42-P
8-2x	BD-B342799A	PANEL FRONT (A) PART
8-2x	BD-B342799B	PANEL FRONT (A)-P PART
8-3	SZ-342812	WINDOW FRONT
8-4x	ZS-310343	PLX PAN30x06STL CMT
8-5	SK-B342817	KNOB OPERATION PART
8-5x	SK-B342817B	KNOB OPERATION-P PART
8-6x	ZS-325503	PLX PAN30x12STL CMT
8-7	SK-342820A	KNOB POWER
8-7x	SK-342820B	KNOB POWER-P
8-8x	ZG-322189	SPRING (B)
8-9	SK-B342806A	KNOB CAP (C-1) PART
8-9x	SK-B342806B	KNOB CAP (C-1)-P PART
8-10	SK-B342809A	KNOB CAP (E) PART
8-10x	SK-B342809B	KNOB CAP (E)-P PART
8-11	SK-342815	KNOB DEFEAT
8-12	SK-342816A	KNOB TONE (A)
8-13	SK-342816B	KNOB TONE (B)
8-14	SK-342816C	KNOB TONE (C)
8-15	SP-342822E	PANEL DOOR AA-R42
8-15x	SP-342822F	PANEL DOOR AA-R42-P
8-16x	SZ-342794	GUIDE (L)
8-17x	SZ-342795	GUIDE (R)
8-18x	SZ-342796	SLIDER
8-19	SK-342819A	KNOB PUSH
8-19x	SK-342819B	KNOB PUSH-P
8-20	SP-342823A	COVER UPPER
8-20x	SP-342823B	COVER UPPER-P

INDEX

1. MODEL AA-R22/L

PARTS NO.	REF. NO.	PARTS NO.	REF. NO.	PARTS NO.	REF. NO.	PARTS NO.	REF. NO.
BA-A1003A030A	2-1	EF-326613	5-20x	ER-343353	1-FL5	ZS-311745	6-14x
BA-A1003A030B	2-1	EF-601301	5-20x	ER-343419	2-SR2to4	ZS-319460	5-4
BA-A1003A030C	2-1	EF-602550	5-20x	ER-343420	2-SR1	ZS-319460	5-12
BA-A1003A030D	2-1	EF-668474	5-20x	ES-328777	4-SW3	ZS-332541	5-16
BA-A1003A050A	4-1	EI-202218	1-IC3	ES-336780	2-SW27,28	ZS-463353	5-15x
BA-A1003A050B	4-1	EI-300042	2-IC14	ES-336780	2-SW30,31	ZS-463353	5-13
BA-A1003A050C	4-1	EI-315381	1-IC5	ES-336780	2-SW21to25	ZS-498273	5-19x
BA-A1003A060A	3-1	EI-322248	1-IC1	ES-336780	2-SW1	ZS-498273	6-11x
BA-A1003A060B	3-1	EI-322599	3-IC1	ES-336780	2-SW5,13	ZS-565942	5-18x
BA-A1003A060C	3-1	EI-327074	1-X1	ES-336780	2-SW6to12		
BA-A1003A060D	3-1	EI-332259	4-IC2to4	ES-336780	2-SW2to4		
BA-A1003A060E	3-1	EI-336717	1-IC4	ES-336780	2-SW26,29		
BA-A1003A060F	3-1	EI-336761	2-IC1	ES-336780	2-SW14to20		
BA-A1003A060G	3-1	EI-336794	2-IC11,12	ES-343364	5-9x		
BA-A1003A060H	3-1	EI-337600	2-IC10	ES-343366	4-SW1		
BA-A1003A070A	1-1	EI-338171	2-IC9	ES-343367	4-SW2		
BA-A1003A070B	1-1	EI-338171	2-IC15	ES-343377	3-SW1		
BA-A1003A070C	1-1	EI-343349	1-IC2	ES-343688	3-SW2		
BA-A1003A070D	1-1	EI-343371	2-IC4	ES-343689	3-SW2		
BD-A1003A100A	6-1	EI-343373	2-IC2,3	ET-318239	3-TR1		
BD-A1003A100B	6-1x	EI-343374	2-IC5	ET-322598	3-TR3		
BD-A1003A100C	6-1x	EI-343381	3-IC1	ET-322775	1-TR28		
BD-A1003A100D	6-1x	EI-343417	2-IC6to8	ET-322775	1-TR16		
BD-B342760A	6-2x	EI-343417	2-IC13	ET-322775	1-TR18to20		
BD-B342760B	6-2x	EI-344764	4-IC1	ET-322775	1-TR30		
BT-343356	5-11	EJ-309941	1-TM1	ET-322778	1-TR12to15		
BT-343357	5-11x	EJ-329610	5-3	ET-322778	1-TR23to26		
BT-343358	5-11x	EJ-343362	5-2	ET-322778	1-TR29		
BT-343359	5-11x	EJ-343365	4-J1to3	ET-323529	3-TR4		
BT-343360	5-11x	EJ-343378	3-TM1	ET-324134	3-TR2		
EC-325320	3-C14	EJ-343379	3-J2	ET-330588	1-TR17		
EC-330692	1-VC6	EJ-343380	3-J2	ET-336867	1-TR1		
EC-330692	1-VC5	EM-343376	2-IND1	ET-336869	1-TR2		
EC-330692	1-VC7	EO-202215	1-T6	ET-336935	1-TR5		
EC-337772	1-VC1to4	EO-202216	1-T9	ET-336937	1-TR27		
EC-343976	3-C16	EO-307786	1-T7	ET-337036	1-TR8to10		
EC-344157	2-C13	EO-332120	1-L5	ET-337744	1-TR3		
EC-344478	1-C56	EO-336831	1-T1	ET-338410	1-TR11		
EC-344478	1-C57	EO-336833	2-T1,2	ET-342707	2-TR1,2		
EC-344480	2-SC1	EO-336871	1-L4	ET-452531	1-TR22		
EC-344481	1-C71	EO-336872	1-L1	ET-618873	1-TR4		
EC-344482	1-C72	EO-336873	1-L2	ET-6212351	1-TR6,7		
EC-344482	4-C25	EO-336878	1-T2	ET-655356	1-TR21		
EC-344483	1-C65	EO-336879	1-T3	EV-337993	1-VR1		
EC-344484	1-C62,63	EO-336938	1-L3	EV-337995	1-VR2		
EC-344486	1-C56	EO-337598	1-T4	EW-305691	5-5x		
EC-344486	1-C57	EO-337599	1-T5	EW-306428	5-5		
ED-200213	3-D7	EO-337880	3-L1	EW-336923	5-5x		
ED-200469	2-D11	EO-343351	1-T8	EW-336924	5-5x		
ED-200469	2-D12	ER-200940	3-R8	EW-343363	5-5x		
ED-200469	2-D13	ER-233583	5-14x	EW-347025	5-5x		
ED-300257	2-D14	ER-306127	3-R23	SA-332850	5-17		
ED-301911	1-D19to23	ER-306127	3-R19	SK-342819A	6-10		
ED-301911	1-D9	ER-308028	3-R16	SK-342819B	6-10x		
ED-301911	1-D25	ER-311685	3-R10	SK-342820A	6-3		
ED-301911	1-D5,6	ER-315407	1-FL1	SK-342820B	6-3x		
ED-301911	2-D3to10	ER-318248	1-FR1	SP-342756A	5-1		
ED-307690	4-D1,2	ER-321153	3-R17	SP-342756B	5-1x		
ED-323057	1-D10	ER-322421	1-R123	SP-342756C	5-1x		
ED-330207	3-D8,9	ER-322591	3-R7	SP-342756D	5-1x		
ED-336805	1-D15to18	ER-322787	1-R120	SP-342756E	5-1x		
ED-336832	1-D1to4	ER-322787	3-R28	SP-342756F	5-1x		
ED-337605	1-D7,8	ER-323074	4-R11	SP-342759A	6-12		
ED-337990	3-D3	ER-324184	1-R101	SP-342759B	6-12x		
ED-343410	2-D1,2	ER-324185	1-R100	SP-342763A	6-7		
ED-343412	1-D12	ER-324337	1-R32,33	SP-342763B	6-7x		
ED-343412	1-D13	ER-324337	1-R21,22	SP-342763C	6-7x		
ED-343413	1-D14	ER-324337	1-R46,47	SP-342763D	6-7x		
ED-343854	3-D5,6	ER-324337	1-R60,61	SZ-332739	5-8		
ED-345149	3-D1,2	ER-325114	1-R147	SZ-342762	6-8		
ED-345149	3-D4	ER-325269	2-R12,13	SZ-342765A	6-5x		
ED-346060	1-D24	ER-325269	4-R10	SZ-342765B	6-5x		
EE-337976	5-21	ER-328065	3-R27	SZ-342765C	6-6x		
EF-249851	5-20x	ER-333363	3-R20	SZ-342765D	6-6x		
EF-306951	5-20x	ER-333625	3-R26	SZ-631945	5-6		
EF-306956	5-20x	ER-336804	1-FL2	ZG-322189	6-4x		
EF-306957	5-20x	ER-337327	1-FL4	ZS-308846	6-13x		
EF-309390	5-20x	ER-337328	1-FL4	ZS-309315	5-7		
EF-311839	5-20x	ER-341654	1-FL3	ZS-309315	5-10x		
EF-325683	5-20x	ER-343352	1-FL5	ZS-310343	6-9x		

INDEX

2. MODEL AA-R32/L

PARTS NO.	REF. NO.	PARTS NO.	REF. NO.	PARTS NO.	REF. NO.	PARTS NO.	REF. NO.
BA-A1004A020A	2-1	ED-346157	2-D23	ER-336804	1-FL2	SP-342822C	8-15x
BA-A1004A020B	2-1	EE-337976	7-15	ER-337327	1-FL4	SP-342822D	8-15x
BA-A1004A020C	2-1	EF-300599	7-16x	ER-337328	1-FL4	SP-342823A	8-17
BA-A1004A020D	2-1	EF-309390	7-16x	ER-337756	2-FR3,4	SP-342823B	8-17x
BA-A1004A020E	2-1	EF-326639	7-16x	ER-337773	2-R21	SZ-342794	8-19x
BA-A1004A020F	2-1	EF-326639	7-16x	ER-341654	1-FL3	SZ-342795	8-20x
BA-A1004A050A	1-1	EF-346139	7-16x	ER-343354	1-FL5	SZ-342796	8-21x
BA-A1004A050B	1-1	EI-202218	1-IC3	ER-343355	1-FL5	SZ-342812	8-3
BA-A1004A050C	1-1	EI-300042	3-IC9,10	ER-343409	3-SR1	SZ-631945	7-8
BA-A1004A050D	1-1	EI-315381	1-IC5	ES-336780	4-SW13to16	ZG-322189	8-7x
BA-A1004A060A	3-1	EI-315799	2-IC1,2	ES-336780	4-SW1to11	ZS-308846	8-18
BA-A1004A060B	3-1	EI-322248	1-IC1	ES-336780	5-SW11to20	ZS-310343	8-4x
BA-A1004A060C	3-1	EI-323563	2-IC1	ES-336780	5-SW1to8	ZS-319460	7-13
BA-A1004A060D	3-1	EI-327074	1-X1	ES-343367	7-9x	ZS-319460	7-4
BD-A1004A080A	8-1	EI-332259	3-IC15to17	ES-343391	2-SW1	ZS-325503	8-8x
BD-A1004A080B	8-1x	EI-336717	1-IC4	ES-343392	2-SW2	ZS-342792B	7-19
BD-B342799C	8-2x	EI-336761	2-IC3	ES-343398	3-SW1	ZS-463353	7-10x
BD-B342799D	8-2x	EI-337013	3-IC3to6	ES-343399	3-SW2	ZS-522865	7-6
BT-343384	7-18	EI-337600	3-IC2	ES-343400	3-SW3	ZS-530673	7-14x
BT-343385	7-18x	EI-338171	3-IC7,8	ES-343688	6-SW1		
BT-343386	7-18x	EI-343349	1-IC2	ES-343689	6-SW1		
BT-343387	7-18x	EI-343375	3-IC11to13	ET-300931	2-TR9		
BT-343388	7-18x	EI-343374	3-IC1	ET-301165	2-TR11		
EC-314688	6-C1	EI-343390	2-IC2	ET-305463	2-TR1		
EC-320548	2-C22,23	EI-344490	3-IC14	ET-307195	2-TR12		
EC-320548	6-C1	EI-344764	1-IC11	ET-307195	2-TR2to6		
EC-330692	1-VC5	EJ-329610	7-3	ET-322775	1-TR19,20		
EC-330692	1-VC7	EJ-336905	1-J1	ET-322775	1-TR16		
EC-330692	1-VC6	EJ-343362	7-2	ET-322775	1-TR18		
EC-336882	3-C50	EJ-343389	7-5	ET-322775	1-TR6to8		
EC-337151	2-C16	EJ-343395	2-J1	ET-322775	1-TR10		
EC-337772	1-VC1to4	EJ-343396	2-J1	ET-322775	1-TR28		
EC-338380	2-C10	EJ-343401	3-J15,16	ET-322775	1-TR24to26		
EC-338496	6-C1	EM-343397	4-IND1	ET-322775	3-TR1,2		
EC-343393	2-C28,29	EO-202215	1-T6	ET-322778	1-TR9		
EC-343855	2-C9	EO-202216	1-T9	ET-322778	1-TR12to15		
EC-344478	1-C57	EO-307786	1-T7	ET-322778	1-TR23		
EC-344478	1-C56	EO-332120	1-L5	ET-328440	2-TR8		
EC-344480	3-SC2	EO-336831	1-T1	ET-330588	1-TR17		
EC-344481	1-C71	EO-336833	3-T1,2	ET-336867	1-TR1		
EC-344482	1-C72	EO-336871	1-L4	ET-336869	1-TR2		
EC-344482	3-C60	EO-336872	1-L1	ET-336935	1-TR5		
EC-344483	1-C65	EO-336873	1-L2	ET-336937	1-TR27		
EC-344484	1-C62,63	EO-336878	1-T2	ET-337744	1-TR3		
EC-344486	1-C56	EO-336879	1-T3	ET-338410	1-TR11		
EC-344486	1-C57	EO-336938	1-L3	ET-452531	1-TR22		
ED-200749	2-D20	EO-337598	1-T4	ET-452531	2-TR10		
ED-301911	1-D9	EO-337599	1-T5	ET-618873	1-TR4		
ED-301911	1-D5,6	EO-337880	2-L1	ET-655356	1-TR21		
ED-301911	1-D25	EO-344174	1-T8	EV-315540	2-VR1		
ED-301911	1-D19	EP-337159	2-RL1	EV-337993	1-VR1		
ED-301911	1-D22,23	ER-200941	1-R215,216	EV-337995	1-VR2		
ED-301911	2-D1to5	ER-233583	7-11x	EW-328245	7-12x		
ED-301911	2-D18	ER-306127	2-R47	EW-306428	7-12		
ED-301911	2-D21	ER-308875	2-R25,26	EW-313882	7-12x		
ED-301911	2-D7to11	ER-308875	2-R35	EW-336924	7-12x		
ED-301911	3-D29	ER-313699	2-R49,50	EW-343363	7-12x		
ED-301911	3-D30	ER-315407	1-FL1	EW-347025	7-12x		
ED-301911	3-D27	ER-318248	1-FR1	SA-332850	7-17		
ED-301911	3-D23,24	ER-318248	2-FR1,2	SK-B342806A	8-9		
ED-301911	3-D28	ER-322421	1-R123	SK-B342806B	8-9x		
ED-309341	2-D12	ER-322739	7-7	SK-B342809A	8-10		
ED-323057	1-D10	ER-322787	1-R120	SK-B342809B	8-10x		
ED-323354	3-D26	ER-322787	2-R51	SK-B342817	8-5		
ED-325115	2-D6	ER-323074	2-R42	SK-B342817B	8-5x		
ED-330218	2-D14	ER-323075	2-R41	SK-342815	8-11		
ED-330218	2-D16,17	ER-324184	1-R101	SK-342816A	8-12		
ED-330219	2-D15	ER-324185	1-R100	SK-342816B	8-13		
ED-336805	1-D15to18	ER-324185	1-R32	SK-342816C	8-14		
ED-336832	1-D1to4	ER-324337	1-R21,22	SK-342819A	8-16		
ED-337153	2-D22	ER-324337	1-R60,61	SK-342819B	8-16x		
ED-337153	3-D25	ER-324337	1-R46,47	SK-342820A	8-6		
ED-337153	3-D11to22	ER-325114	1-R147	SK-342820B	8-6x		
ED-337605	1-D7,8	ER-325269	2-R39,40	SP-342791A	7-1		
ED-343410	3-D1,2	ER-325269	2-R9,11	SP-342791B	7-1x		
ED-343412	1-D12	ER-325269	2-R12,15	SP-342791D	7-1x		
ED-343412	1-D13	ER-328519	2-FR5,6	SP-342791E	7-1x		
ED-343413	1-D14	ER-333044	2-R34	SP-342791F	7-1x		
ED-344177	2-D13	ER-333067	2-R33	SP-342822A	8-15		
ED-346116	2-D19	ER-333598	2-R43	SP-342822B	8-15x		

INDEX

3. MODEL AA-R42

PARTS NO.	REF. NO.	PARTS NO.	REF. NO.	PARTS NO.	REF. NO.	PARTS NO.	REF. NO.
BA-A1005A020A	2-1	EF-346115	7-18x	ES-336780	6-SW1to20		
BA-A1005A020B	2-1	EF-593706	7-18x	ES-342910	2-SW1		
BA-A1005A020C	2-1	EF-691007	7-18x	ES-343398	3-SW1		
BA-A1005A020D	2-1	EI-202218	1-IC3	ES-343399	3-SW2		
BA-A1005A020E	2-1	EI-213390	1-IC11	ES-343400	3-SW3		
BA-A1005A020F	2-1	EI-315381	1-IC5	ES-343407	2-SW2		
BA-A1005A040A	1-1	EI-315799	2-IC1,2	ES-343688	4-SW1		
BA-A1005A040B	1-1	EI-322248	1-IC1	ES-343689	4-SW1		
BA-A1005A040C	1-1	EI-326595	2-IC1	ET-300931	2-TR10		
BA-A1005A050A	3-1	EI-327074	1-X1	ET-301165	2-TR12		
BA-A1005A050B	3-1	EI-332259	3-IC15to17	ET-305463	2-TR2		
BA-A1005A050C	3-1	EI-336717	1-IC4	ET-307195	2-TR3to5		
BD-A1005A070A	8-1	EI-336761	2-IC3	ET-307195	2-TR13		
BD-A1005A070B	8-1x	EI-337013	3-IC3to6	ET-316171	2-TR6,7		
BD-B342799A	8-2x	EI-337600	3-IC2	ET-322775	1-TR10,18		
BD-B342799B	8-2x	EI-338171	3-IC7,8	ET-322775	1-TR24to26		
BT-343402	7-1	EI-343349	1-IC2	ET-322775	1-TR6to8		
BT-343403	7-1x	EI-343373	3-IC9to13	ET-322775	3-TR1to3		
BT-343404	7-1x	EI-343374	3-IC1	ET-322778	1-TR9		
BT-343405	7-1x	EI-343406	2-IC2	ET-322778	1-TR23		
EC-314688	4-C1	EI-344490	3-IC4	ET-323529	3-TR4		
EC-320548	4-C1	EJ-309941	1-TM1	ET-328440	2-TR9		
EC-323847	1-C102	EJ-329610	7-10	ET-336867	1-TR1		
EC-330692	1-VC5	EJ-336905	1-J1	ET-336869	1-TR2		
EC-330692	1-VC7	EJ-343362	7-9	ET-336935	1-TR5		
EC-334013	2-C13	EJ-343389	7-11	ET-336937	1-TR27		
EC-336882	3-C50	EJ-343395	2-J1	ET-337744	1-TR3		
EC-337772	1-VC1to4	EJ-343396	2-J1	ET-343414	1-TR35		
EC-338496	4-C1	EJ-343401	3-J15,16	ET-343414	2-TR1		
EC-343424	2-C30,31	EM-343397	5-1	ET-452531	1-TR22		
EC-343730	2-C10,11	EO-202215	1-T6	ET-452531	2-TR11		
EC-343855	2-C12	EO-202216	1-T9	ET-618873	1-TR4		
EC-344478	1-C56,57	EO-332116	2-L1	ET-655356	1-TR21		
EC-344480	3-SC2	EO-332120	1-L5	EV-315540	2-VR1		
EC-344481	1-C71	EO-336831	1-T1	EV-337993	1-VR1		
EC-344482	3-C60	EO-336833	3-T1,2	EV-337995	1-VR2		
EC-344483	1-C65	EO-336871	1-L4	EW-328245	7-13x		
EC-344484	1-C62,63	EO-336872	1-L1	EW-306428	7-13		
EC-344486	1-C56,57	EO-336873	1-L2	EW-336924	7-13x		
ED-200469	3-D28,29	EO-336878	1-T2	EW-343363	7-13x		
ED-200749	2-D22	EO-336879	1-T3	SA-332850	7-6		
ED-301911	1-D19,20	EO-336938	1-L3	SK-B342806A	8-9		
ED-301911	1-D9	EO-337598	1-T4	SK-B342806B	8-9x		
ED-301911	1-D22,23	EO-344174	1-T8	SK-B342809A	8-10		
ED-301911	1-D5,6	EP-337159	2-RL1	SK-B342809B	8-10x		
ED-301911	2-17,18	EP-337416	1-RL1	SK-B342817	8-5		
ED-301911	3-D31to34	ER-200747	1-FR2	SK-B342817B	8-5x		
ED-309341	2-D19	ER-233583	7-12x	SK-342815	8-11		
ED-323057	1-D10	ER-308875	2-R38	SK-342816A	8-12		
ED-323354	3-D26	ER-315407	1-FL1	SK-342816B	8-13		
ED-324195	2-D23	ER-318248	1-FR1	SK-342816C	8-14		
ED-330218	2-D14	ER-320538	2-R45	SK-342819A	8-19		
ED-330218	2-D12	ER-322421	1-R123	SK-342819B	8-19x		
ED-330320	2-D21	ER-322787	1-R120	SK-342820A	8-7		
ED-336805	1-D15to18	ER-324184	1-R101	SK-342820B	8-7x		
ED-336832	1-D1to4	ER-324185	1-R32	SP-342791G	7-7		
ED-337153	2-D20	ER-324185	1-R100	SP-342791H	7-7x		
ED-337153	2-D9,10	ER-324337	1-R21,22	SP-342791K	7-7x		
ED-337153	2-D24	ER-324337	1-R46,47	SP-342822E	8-15		
ED-337153	2-D5to7	ER-324337	1-R60,61	SP-342822F	8-15x		
ED-337153	2-D11to3	ER-325114	1-R147	SP-342823A	8-20		
ED-337153	3-D25	ER-325269	2-R39,40	SP-342823B	8-20x		
ED-337153	3-D11to22	ER-326169	2-FR1to3	SZ-332739	7-14		
ED-337605	1-D7,8	ER-327710	1-R215,216	SZ-342794	8-16x		
ED-343410	3-D1,2	ER-333426	2-R46	SZ-342795	8-17x		
ED-343412	1-D12	ER-333598	2-R51	SZ-342796	8-18x		
ED-343412	1-D13	ER-333654	2-R16	SZ-342812	8-3		
ED-343413	1-D14	ER-336804	1-FL2	SZ-631945	7-15		
ED-343415	2-D11	ER-337327	1-FL4	ZG-322189	8-8x		
ED-343421	2-D13	ER-337328	1-FL4	ZS-310343	8-4x		
ED-343422	2-D8	ER-337754	2-R29,30	ZS-319460	7-8		
ED-346133	2-D25	ER-337755	2-R36	ZS-325503	8-6x		
EE-337976	7-17	ER-337794	2-R47	ZS-342792A	7-5		
EF-300601	7-18x	ER-338593	2-R37	ZS-463353	7-16x		
EF-305703	7-18x	ER-341654	1-FL3	ZS-498273	7-4x		
EF-305703	7-18x	ER-343354	1-FL5	ZS-522865	7-2		
EF-309390	7-18x	ER-343355	1-FL5	ZS-530673	7-3x		
EF-309390	7-18x	ER-343409	3-SR1				
EF-326639	7-18x	ER-343423	2-R1				
EF-346115	7-18x	ES-336780	5-SW1to16				

SECTION 5

SCHEMATIC DIAGRAM

1. SCHEMATIC DIAGRAM OF ICs 98
 2. AA-R22/L NO. 3-1 821026A CONNECTION DIAGRAM 107
 3. AA-R22 TUNER NO. 3-2 821027A SCHEMATIC DIAGRAM 108
 4. AA-R22L TUNER NO. 3-3 821028A SCHEMATIC DIAGRAM 109
 5. AA-R32/L NO. 4-1 821029A CONNECTION DIAGRAM 110
 6. AA-R32/L AMP NO. 4-2 821030A SCHEMATIC DIAGRAM 111
 7. AA-R32 TUNER NO. 4-3 821031A SCHEMATIC DIAGRAM 112
 8. AA-R32L NO. 4-4 821032A SCHEMATIC DIAGRAM 113
 9. AA-R42 NO. 3-1 821034A CONNECTION DIAGRAM 114
 10. AA-R42 AMP NO. 3-2 821035A SCHEMATIC DIAGRAM 115
 11. AA-R42 NO. 3-3 821036A SCHEMATIC DIAGRAM 116

HA12019

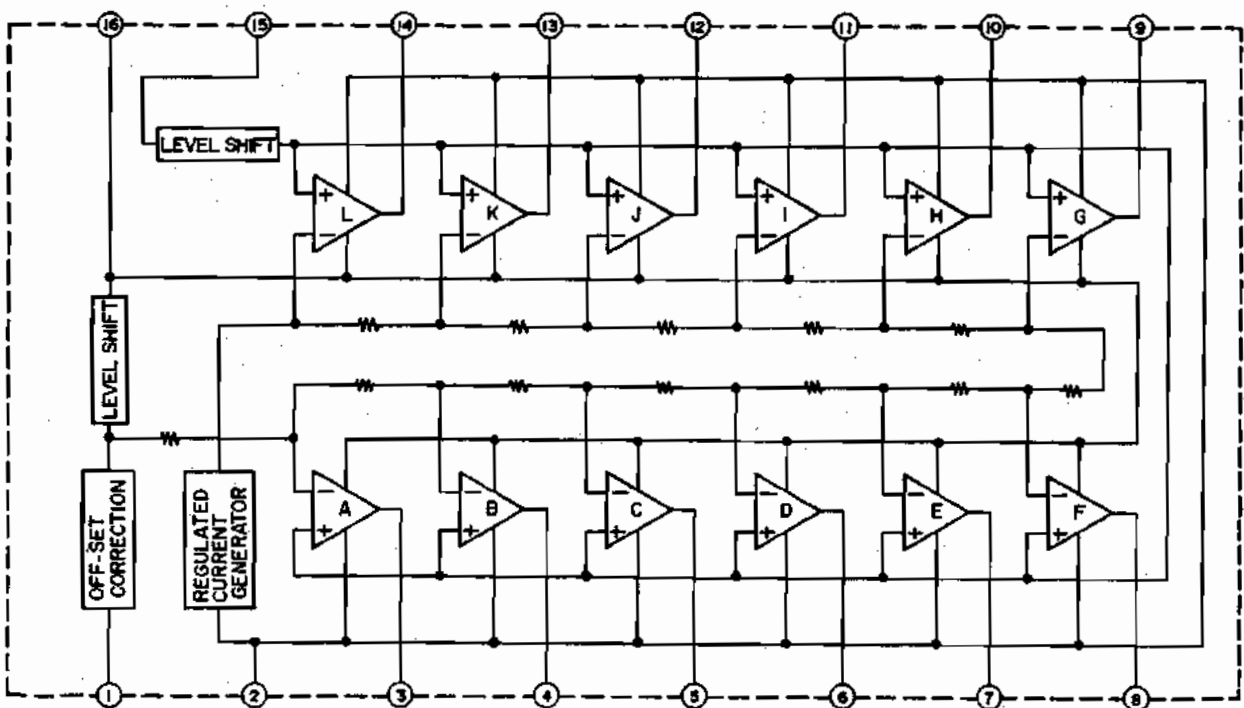

SCHEMATIC DIAGRAM AA-R22/L, AA-R32/L, AA-R42

LA1231N

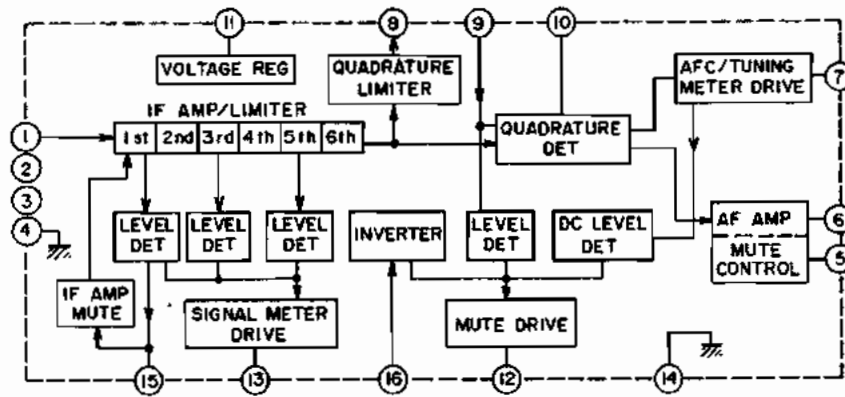

LA1245

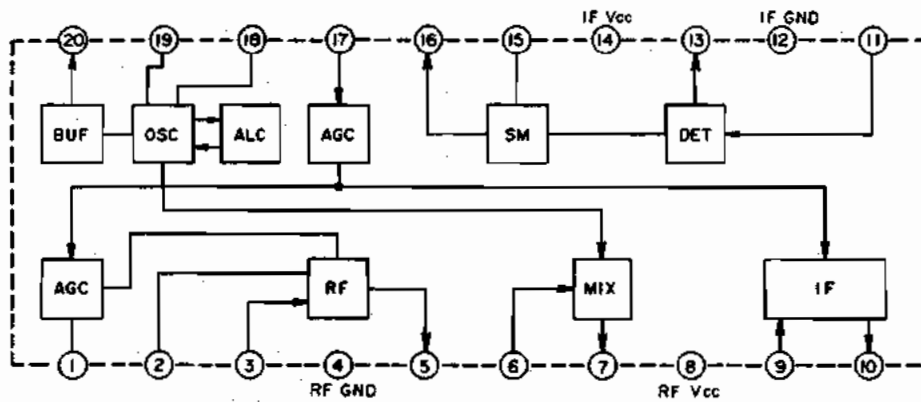

LA3390

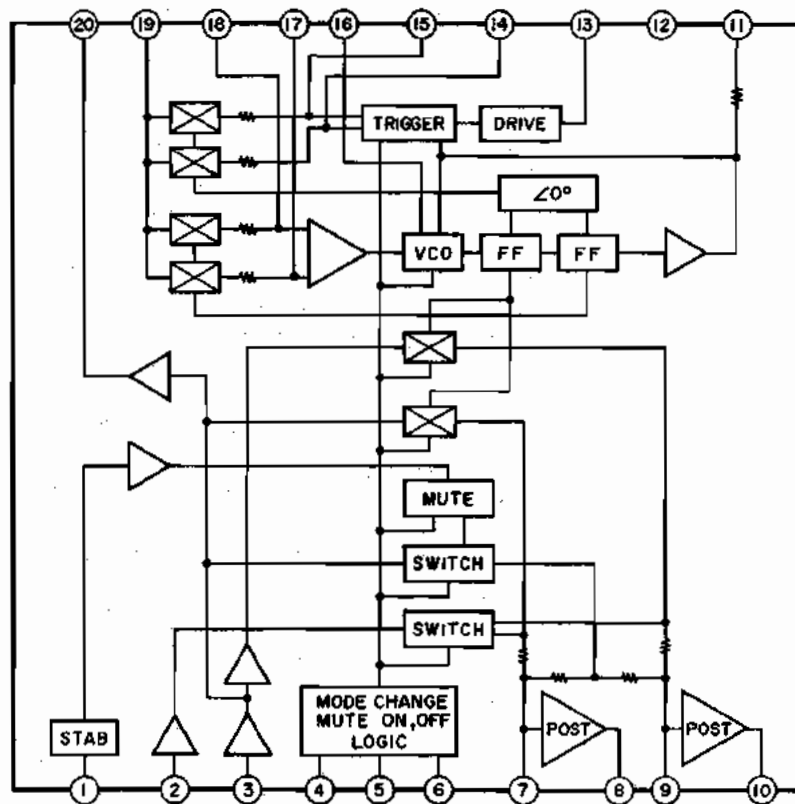

LA6458D/M5218P-21/NJM4558D

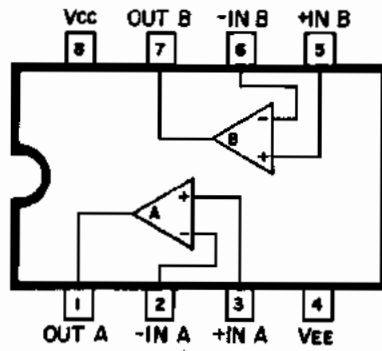

LA6458S/TA75458S

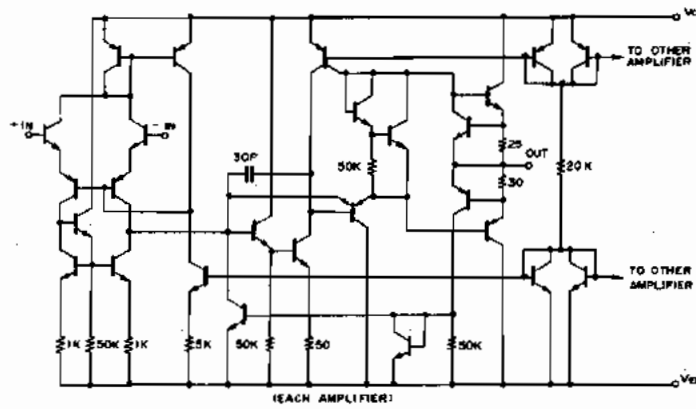
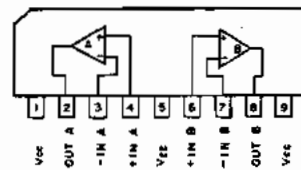

LB1240

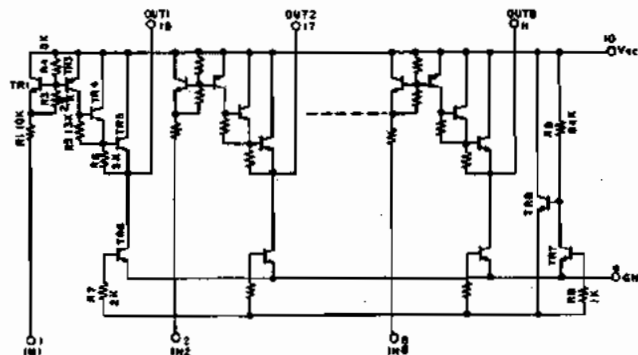
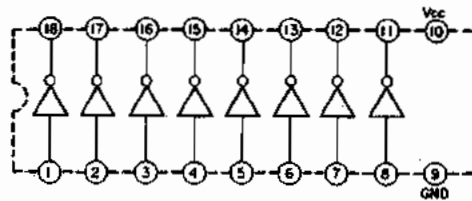

LB1290

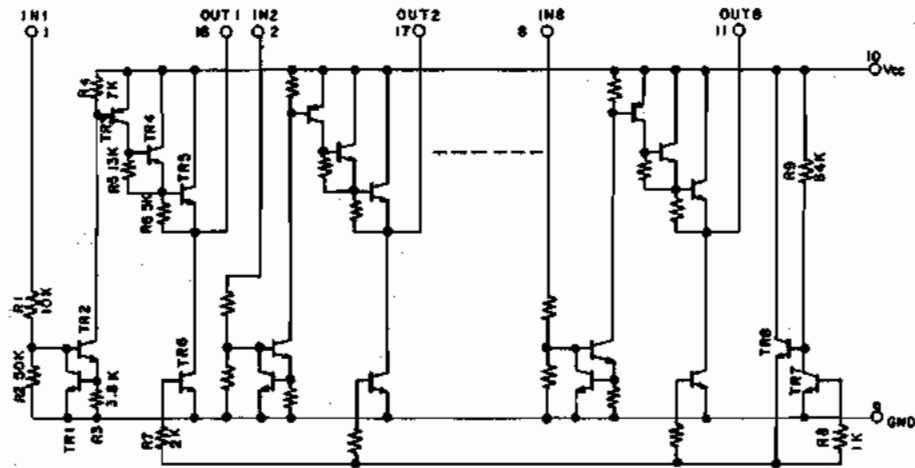
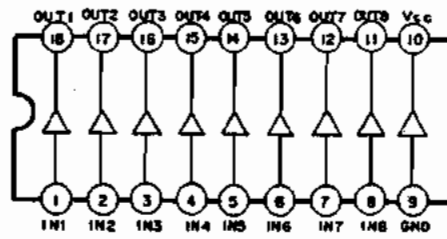

LB1294

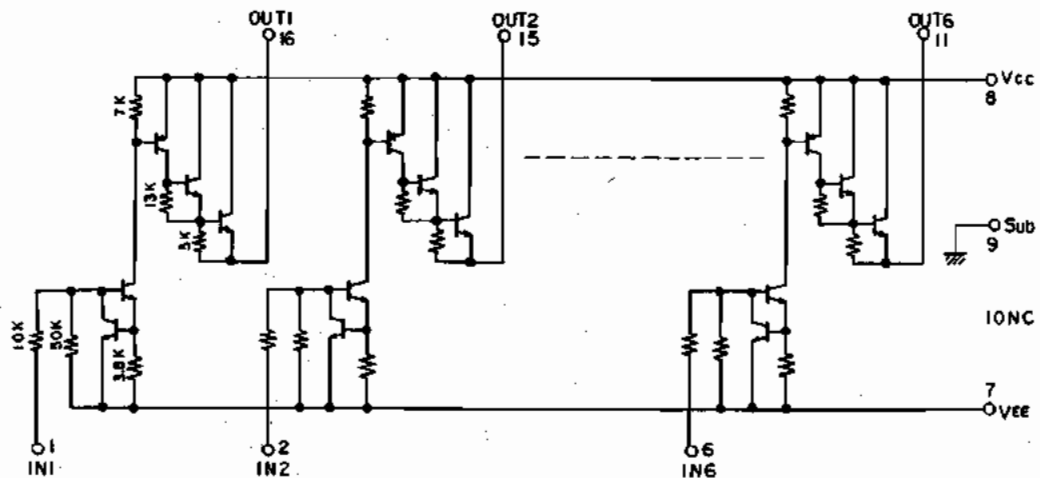
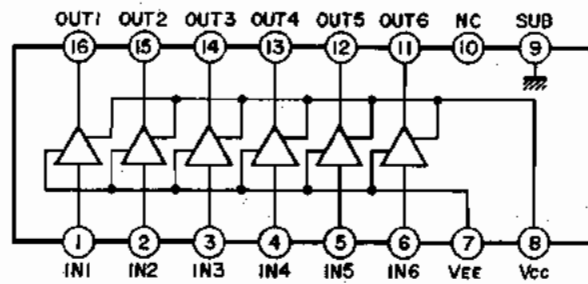

LC4069UB

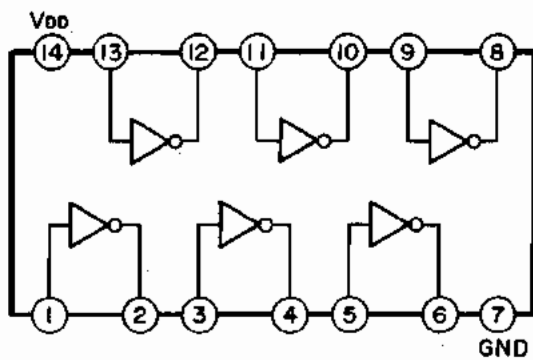

STK-1050/1070

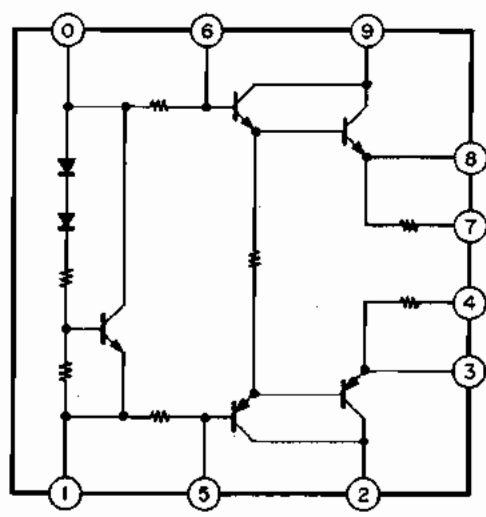

M54519P

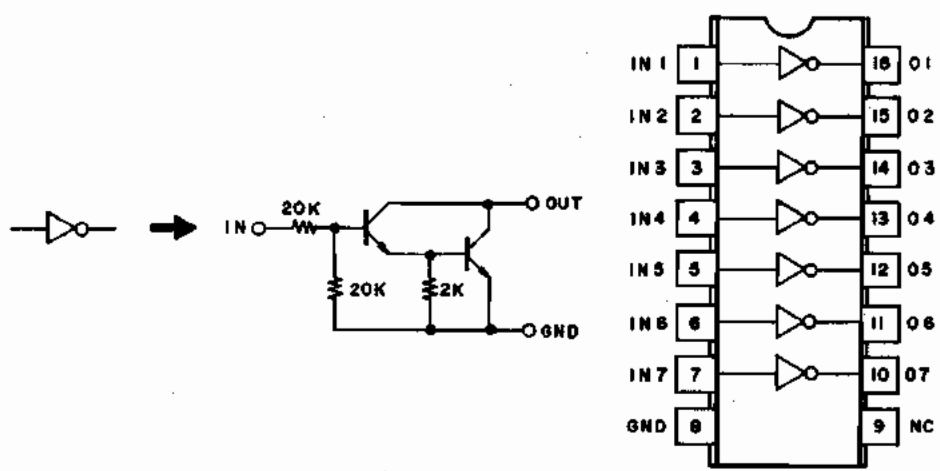

STK-3042/3062

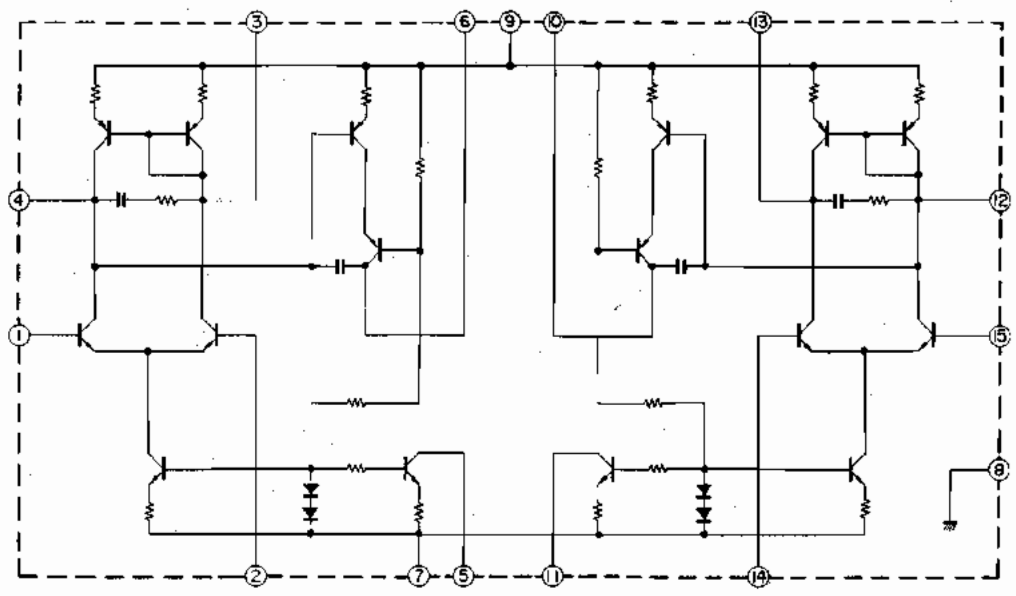

STK-4833

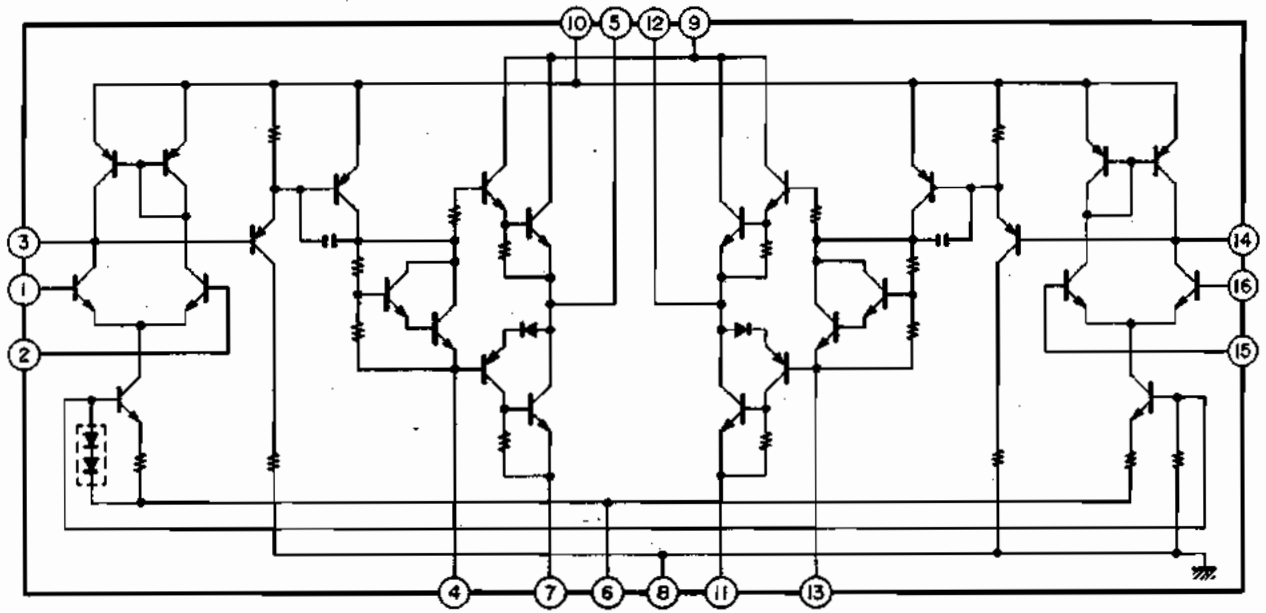

TC4052BP

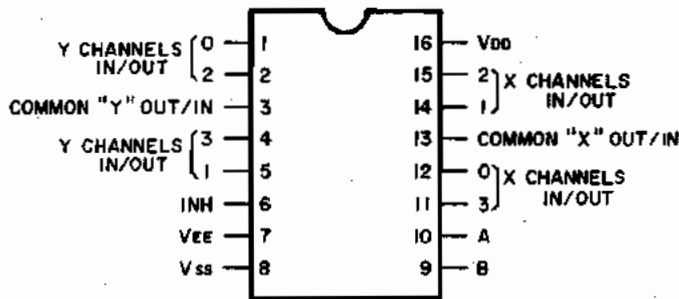

INHIBIT ⑥	A ⑩	B ⑨	"ON" CHANNEL
L	L	L	0X, 0Y
L	H	L	1X, 1Y
L	L	H	2X, 2Y
L	H	H	3X, 3Y
H	X	X	NONE

X=DON'T CARE

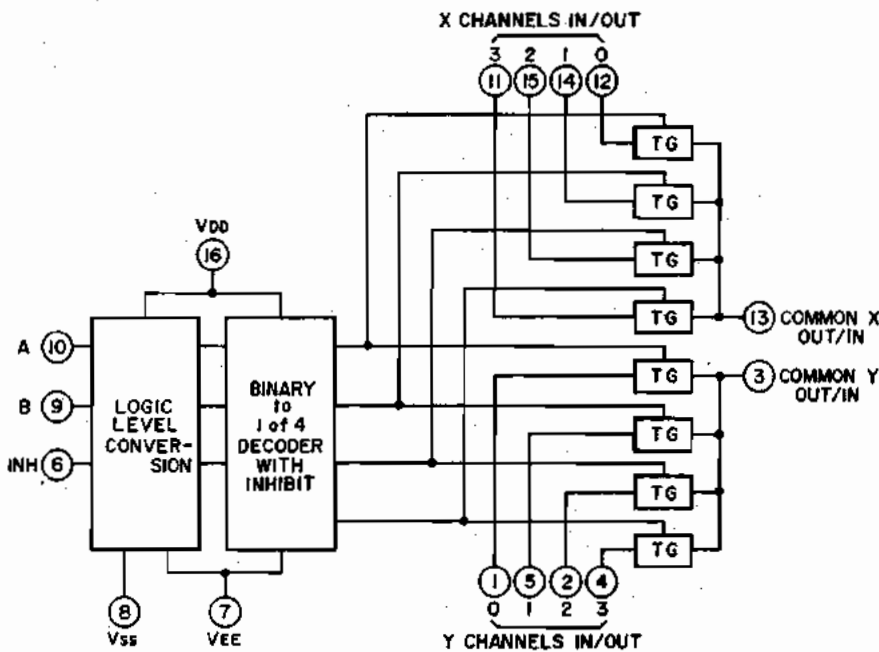

SCHEMATIC DIAGRAM AA-R22/L, AA-R32/L, AA-R42

TC9125BP

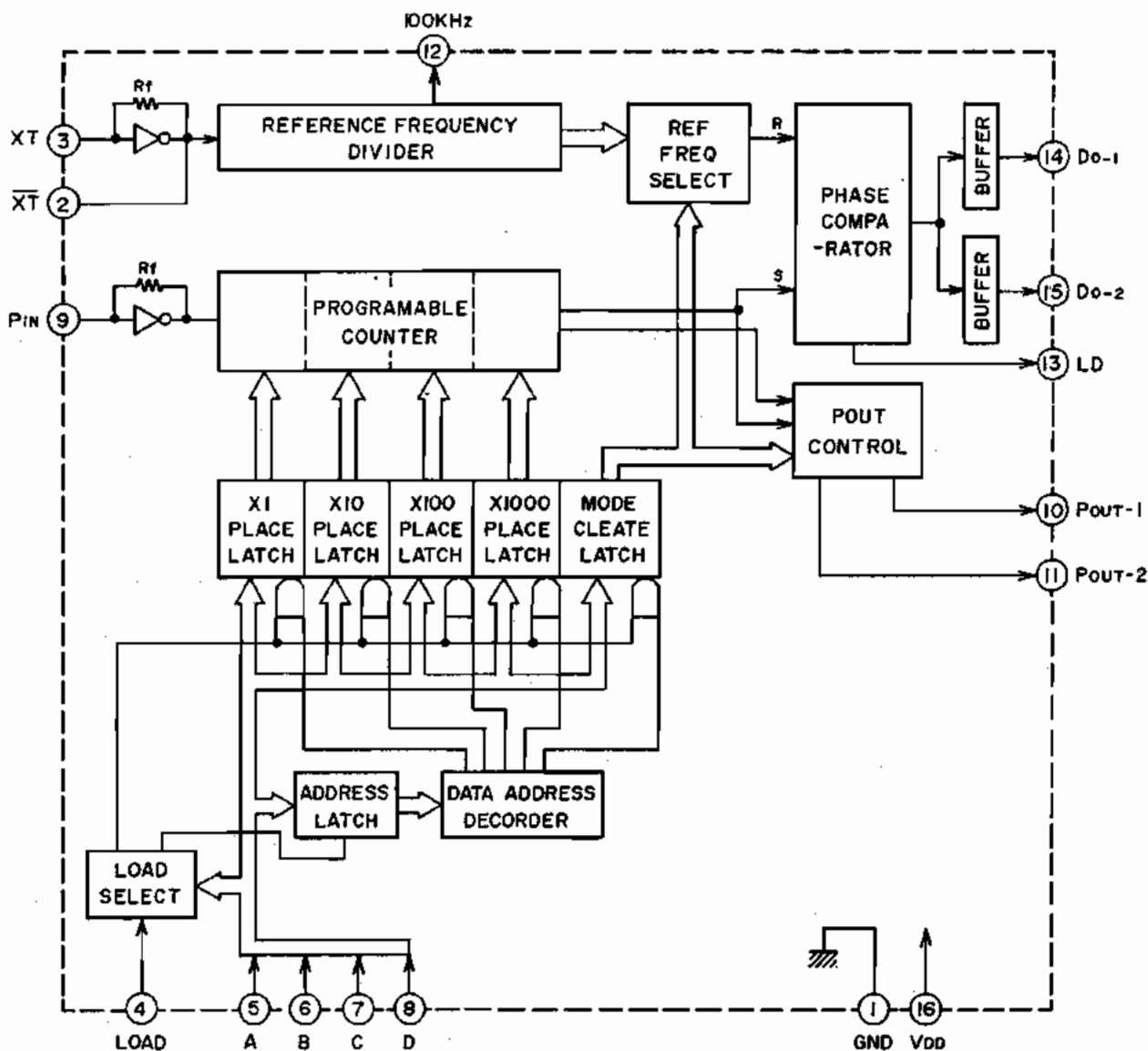

TD6102P

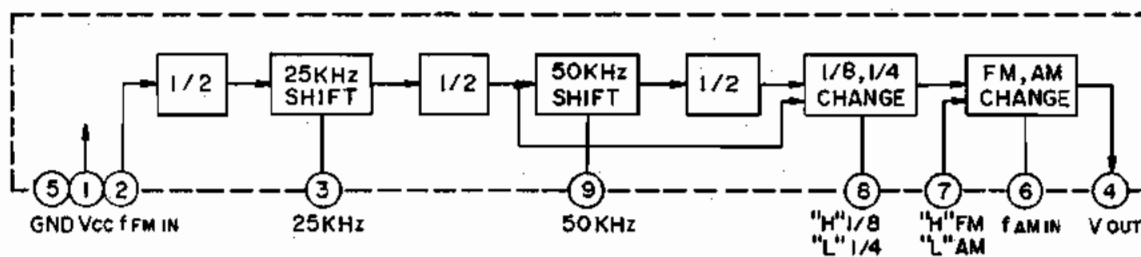

TC9154P

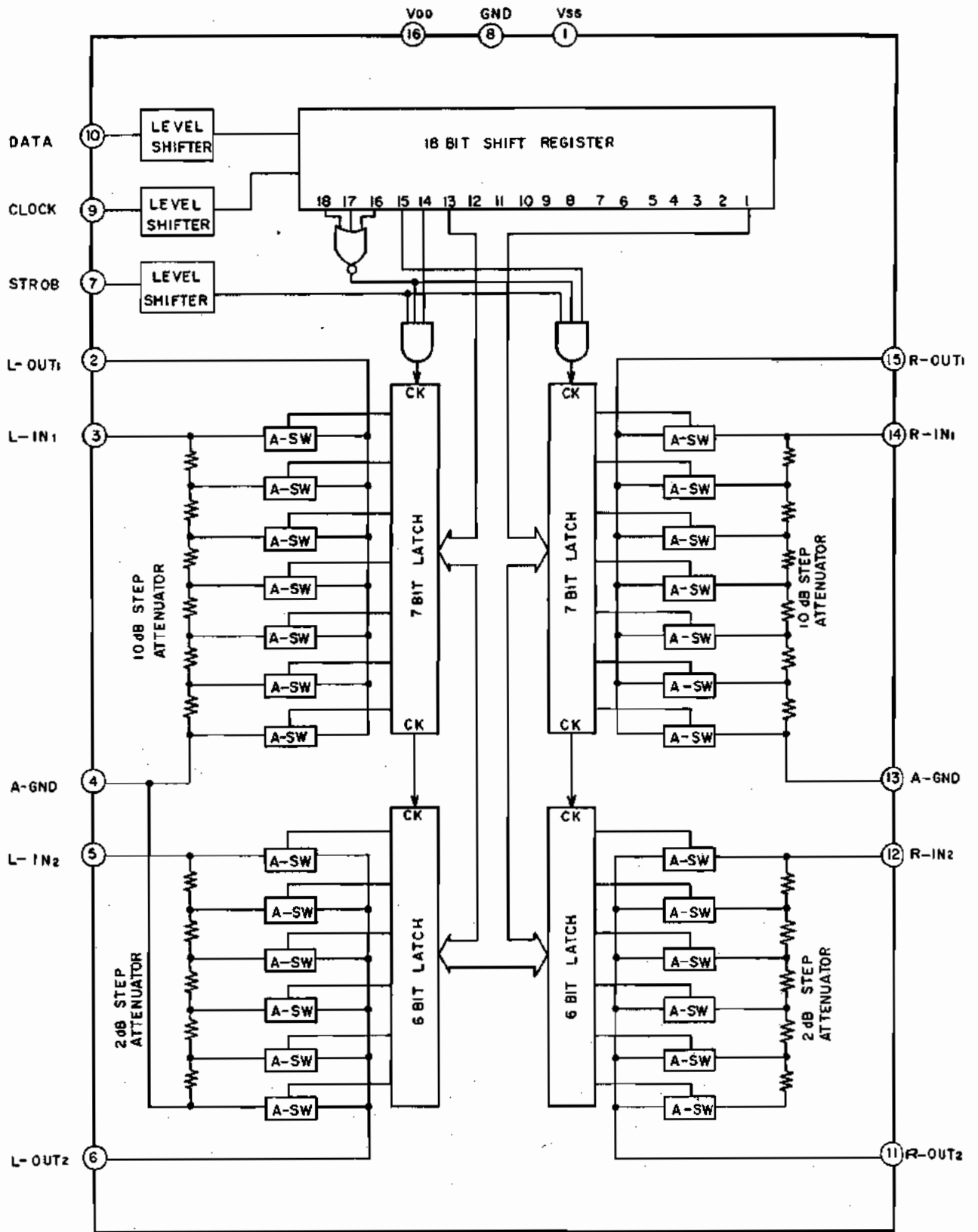

SCHEMATIC DIAGRAM AA-R22/L, AA-R32/L, AA-R42

TC9156P

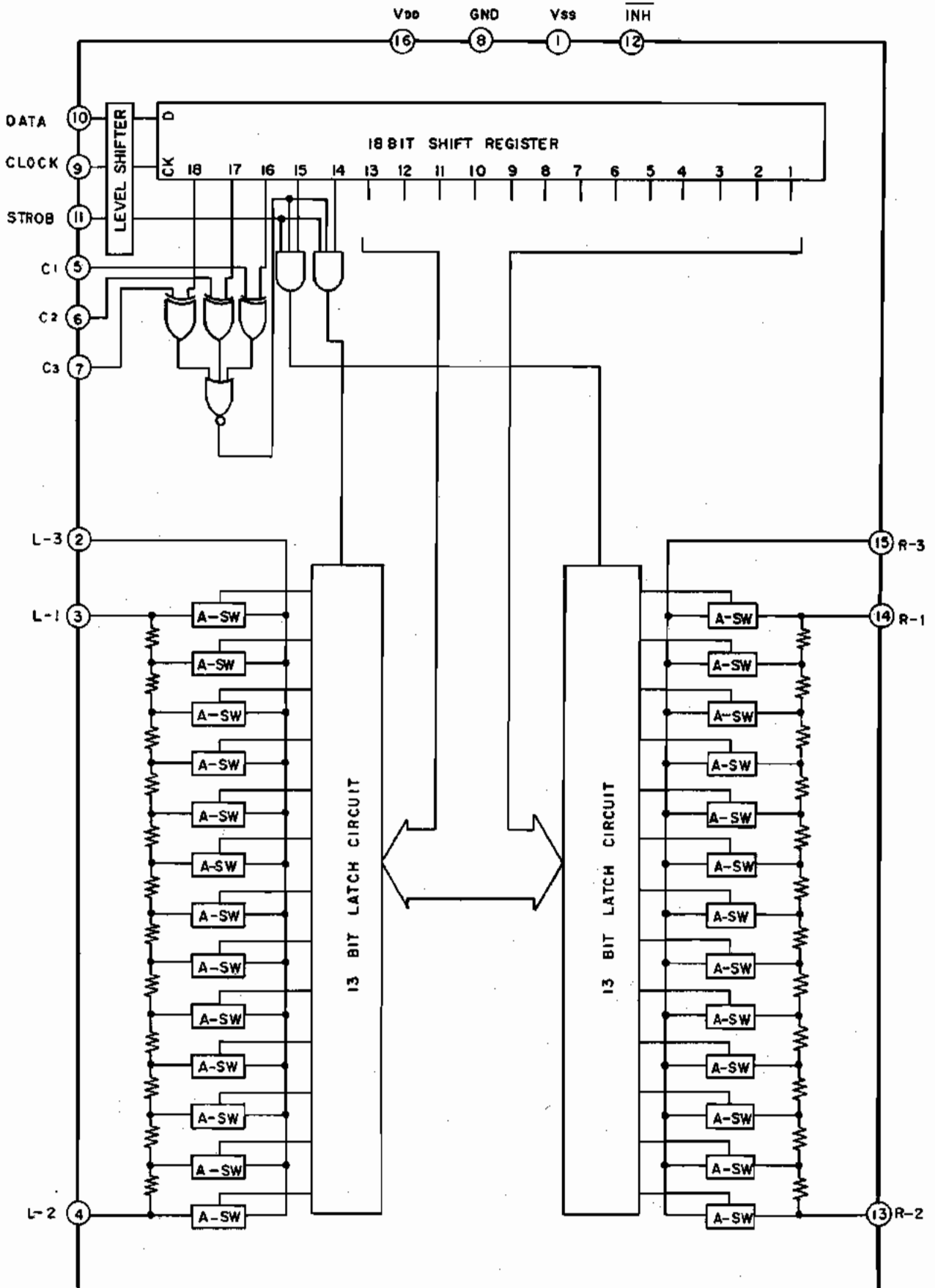

SCHEMATIC DIAGRAM AA-R22/L, AA-R32/L, AA-R42

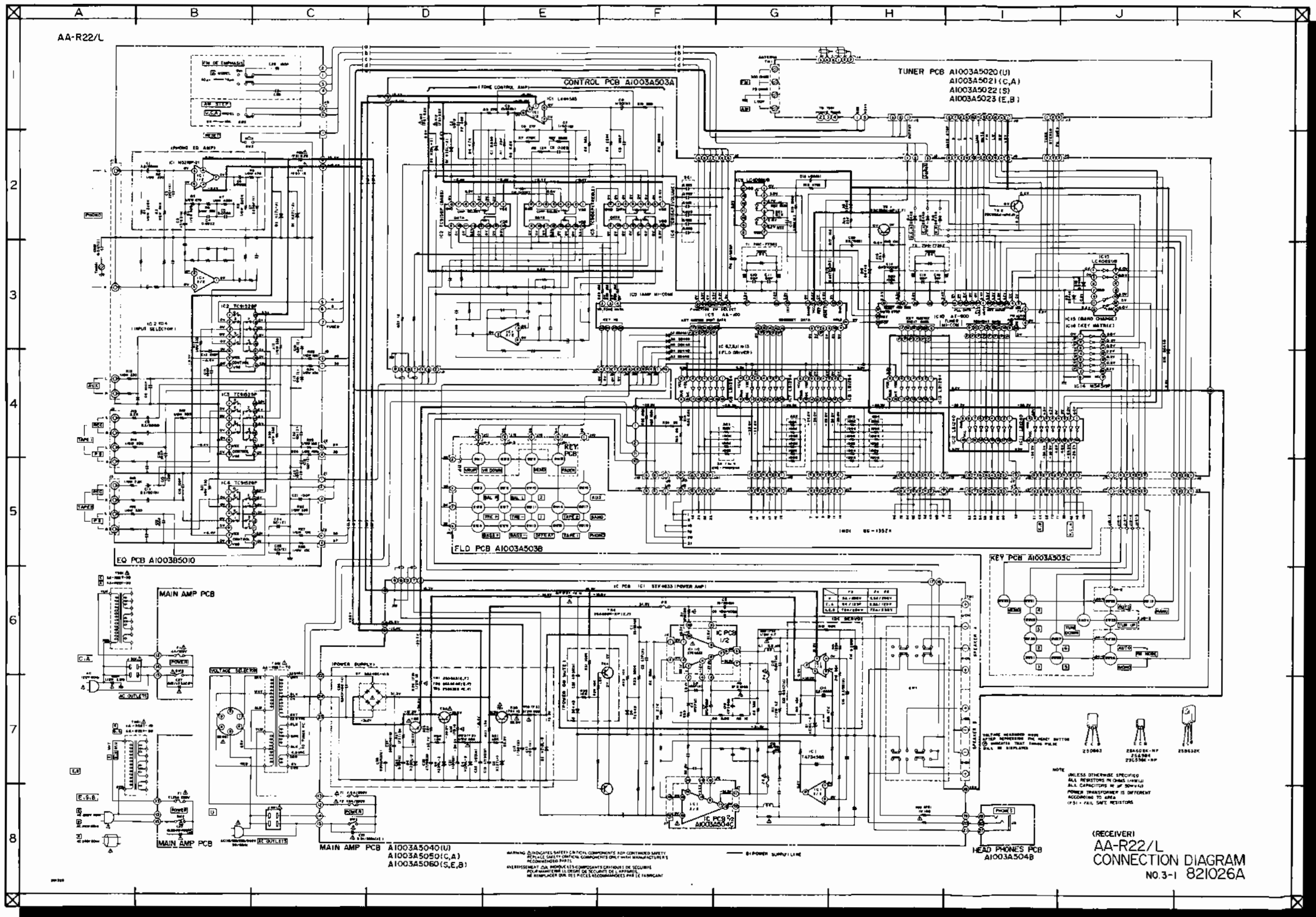

A B C D E F G H I J K

AA-R22

1
2
3
4
5
6
7
8

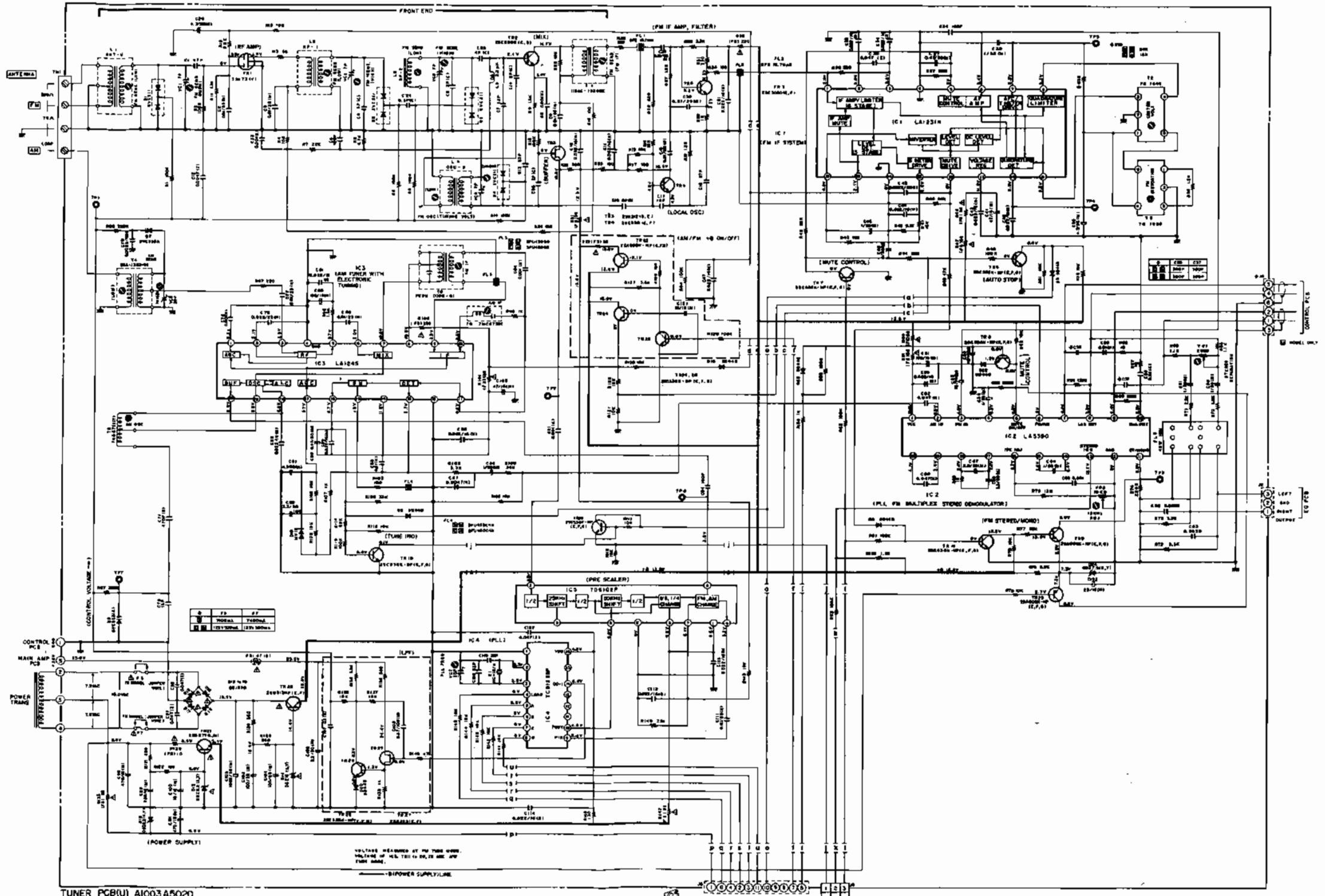

TUNER PCB(U) A1003A5020
 (A.C.) A1003A5021
 (S) A1003A5022

WARNING: INDICATES SAFETY-CRITICAL COMPONENTS FOR CONTINUED SAFETY.
 REPLACE SAFETY CRITICAL COMPONENTS ONLY WITH MANUFACTURER'S
 RECOMMENDED PARTS.
 AVERTISSEMENT: LES COMPOSANTS CRITIQUES DE SECURITE
 NE DOIVENT ETRE REMPLACES QUE PAR LES FABRICANTS
 RECOMMENDES.



NOTE
 UNLESS OTHERWISE SPECIFIED
 ALL RESISTORS IN OHMS (W/VA)
 ALL CAPACITORS IN PF (W/VA)
 (F) = FAIL SAFE RESISTOR

(RECEIVER)
 AA-R22 TUNER
 SCHEMATIC DIAGRAM
 NO.3-2 821027A

AA-R22L

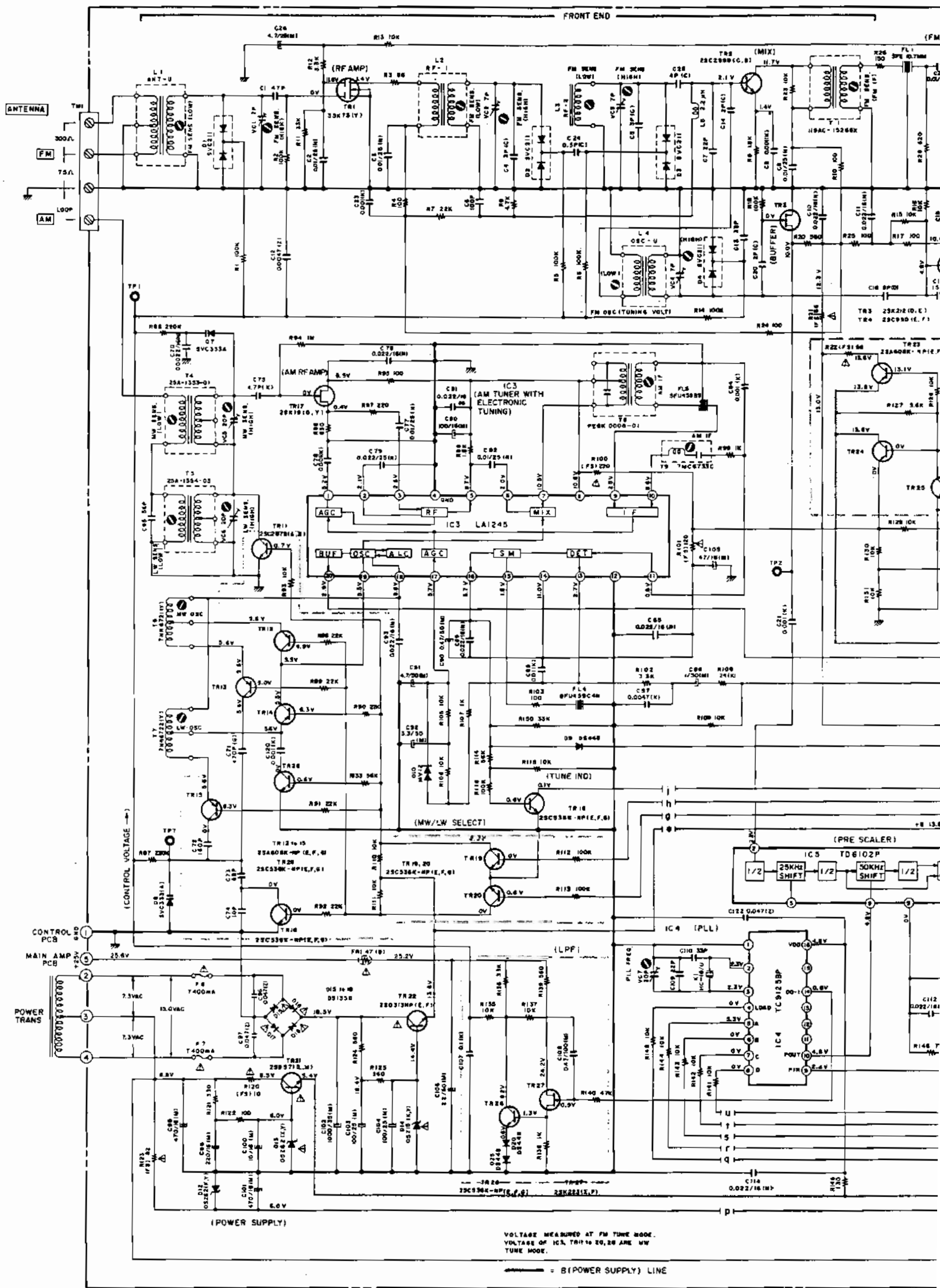

TUNER PCB A1003A5023

WARNING: Δ INDICATES SAFETY CRITICAL COMPONENTS FOR CONTINUED SAFETY. REPLACE SAFETY CRITICAL COMPONENTS ONLY WITH MANUFACTURER'S RECOMMENDED PARTS.
 AVERTISSEMENT: Δ IL INDIQUE LES COMPOSANTS CRITIQUES DE SÉCURITÉ. POUR MAINTENIR LE DEGRÉ DE SÉCURITÉ DE L'APPAREIL, NE REMPLACER QUE DES PIÈCES RECOMMANDÉES PAR LE FABRICANT.

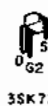

F G H I J K

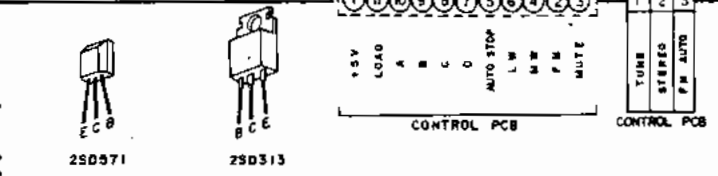
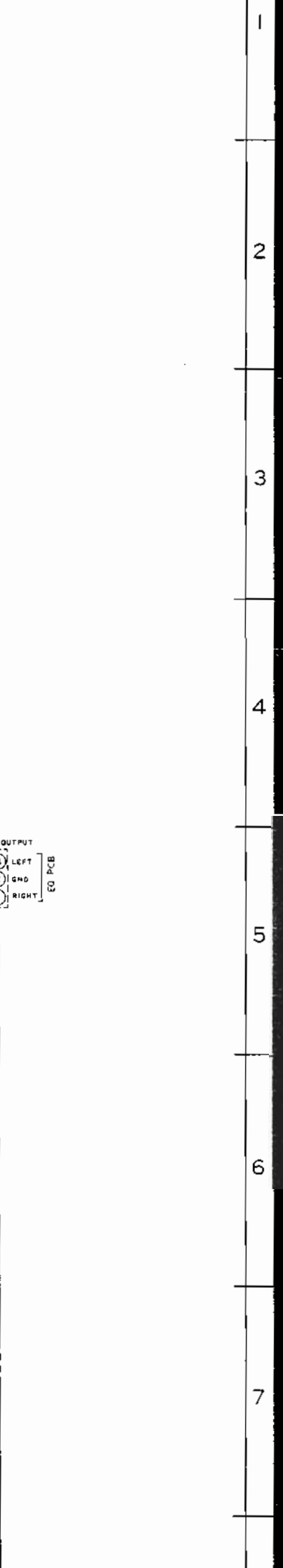
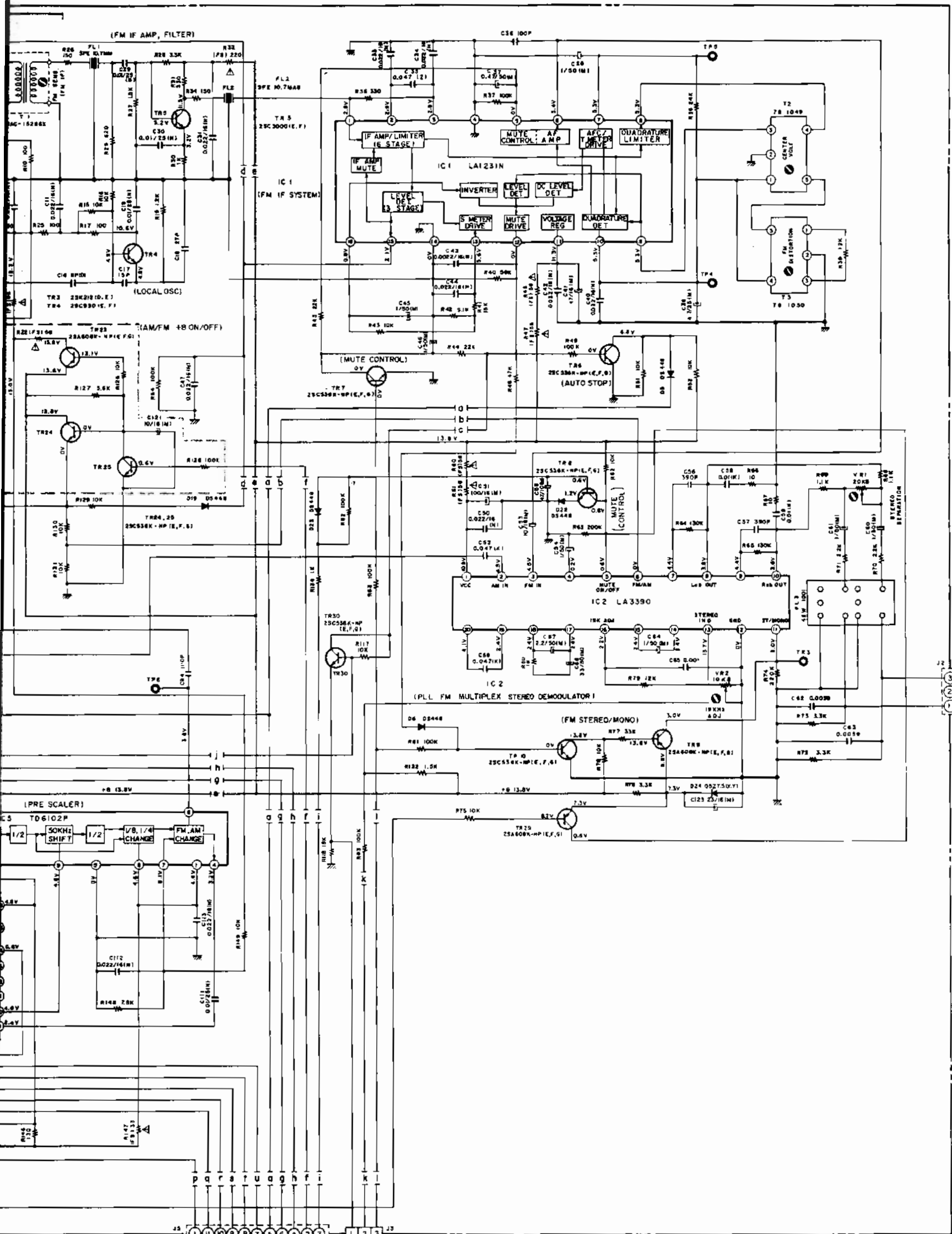

NOTE
UNLESS OTHERWISE SPECIFIED
ALL RESISTORS IN OHMS 1/4W(1)
ALL CAPACITORS IN μ F 50 WV(1)
(FS) = FAIL SAFE RESISTORS

(RECEIVER)
AA-R22L TUNER
SCHEMATIC DIAGRAM
No.3-3 821028A

F G H I J K

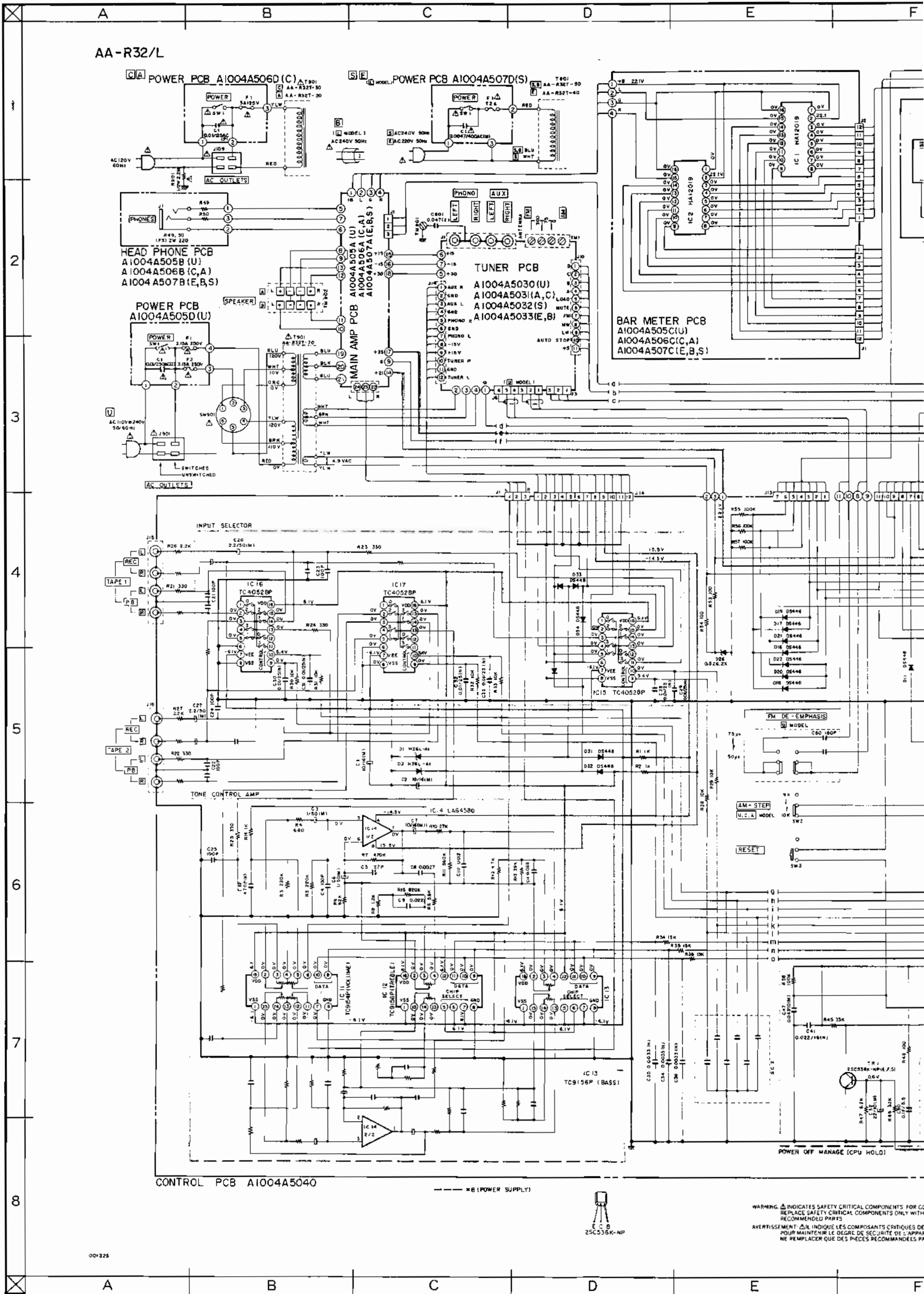

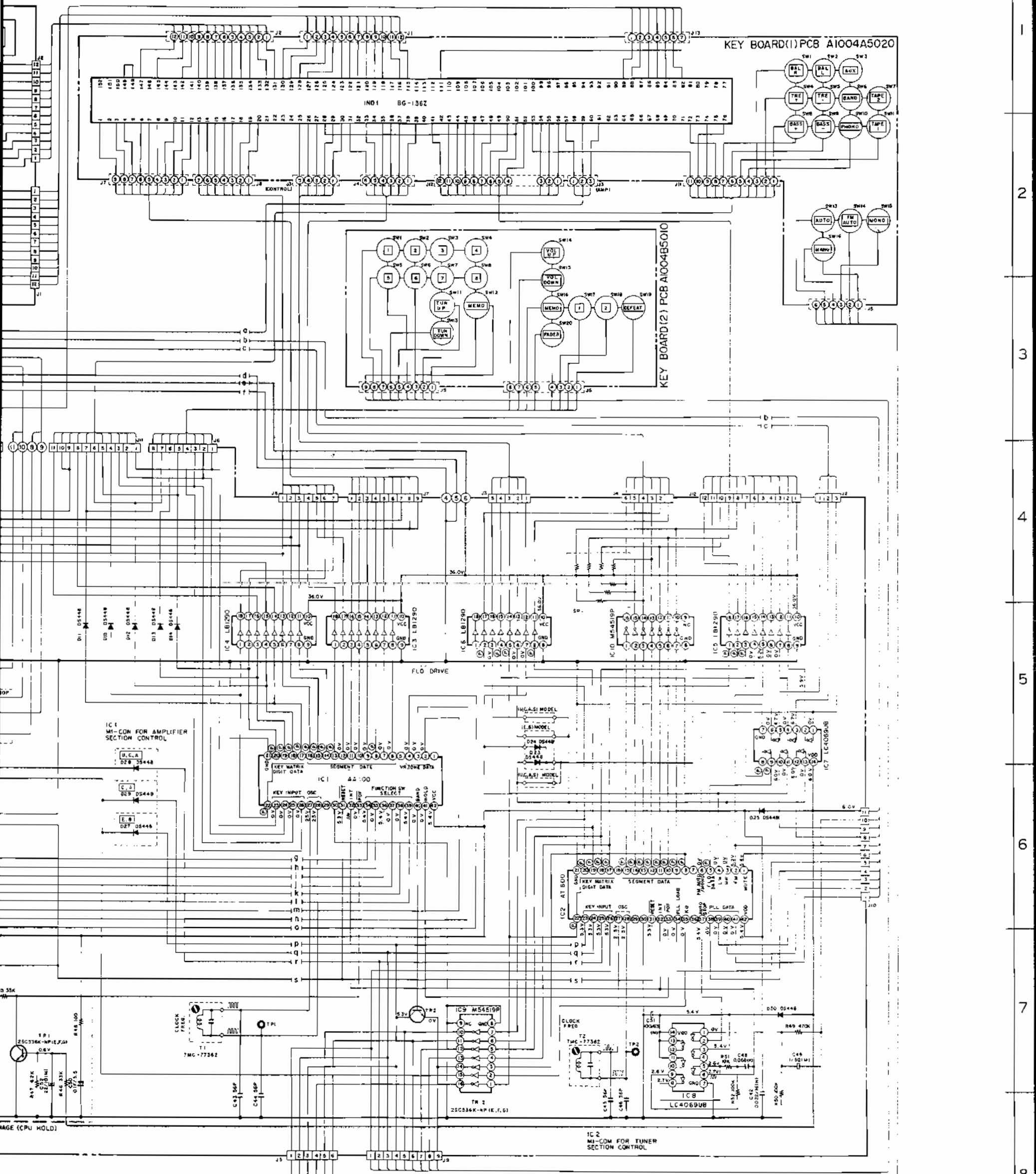

1
2
3
4
5
6
7
8

CRITICAL COMPONENTS FOR CONTINUED SAFETY:
 CRITICAL COMPONENTS ONLY WITH MANUFACTURER'S
 PARTS

LES COMPOSANTS CRITIQUES DE SECURITE:
 SEULEMENT LES COMPOSANTS CRITIQUES DE L'APPAREIL
 AVEC LES PIÈCES RECOMMANDÉES PAR LE FABRICANT

VOLTAGE MEASURED MODE:
 AFTER DEPRESSING "THE RESET BUTTON"
 ⊕ INDICATES THAT TUNING PLUSE WILL BE DISPLAYED

NOTE
 UNLESS OTHERWISE SPECIFIED
 ALL RESISTORS IN OHMS 1/4W(1)
 ALL CAPACITORS IN µF 50V(1)

(RECEIVER)
 AA-R32/L CONNECTION DIAGRAM
 NO.4-1 821029A

AA-R32L

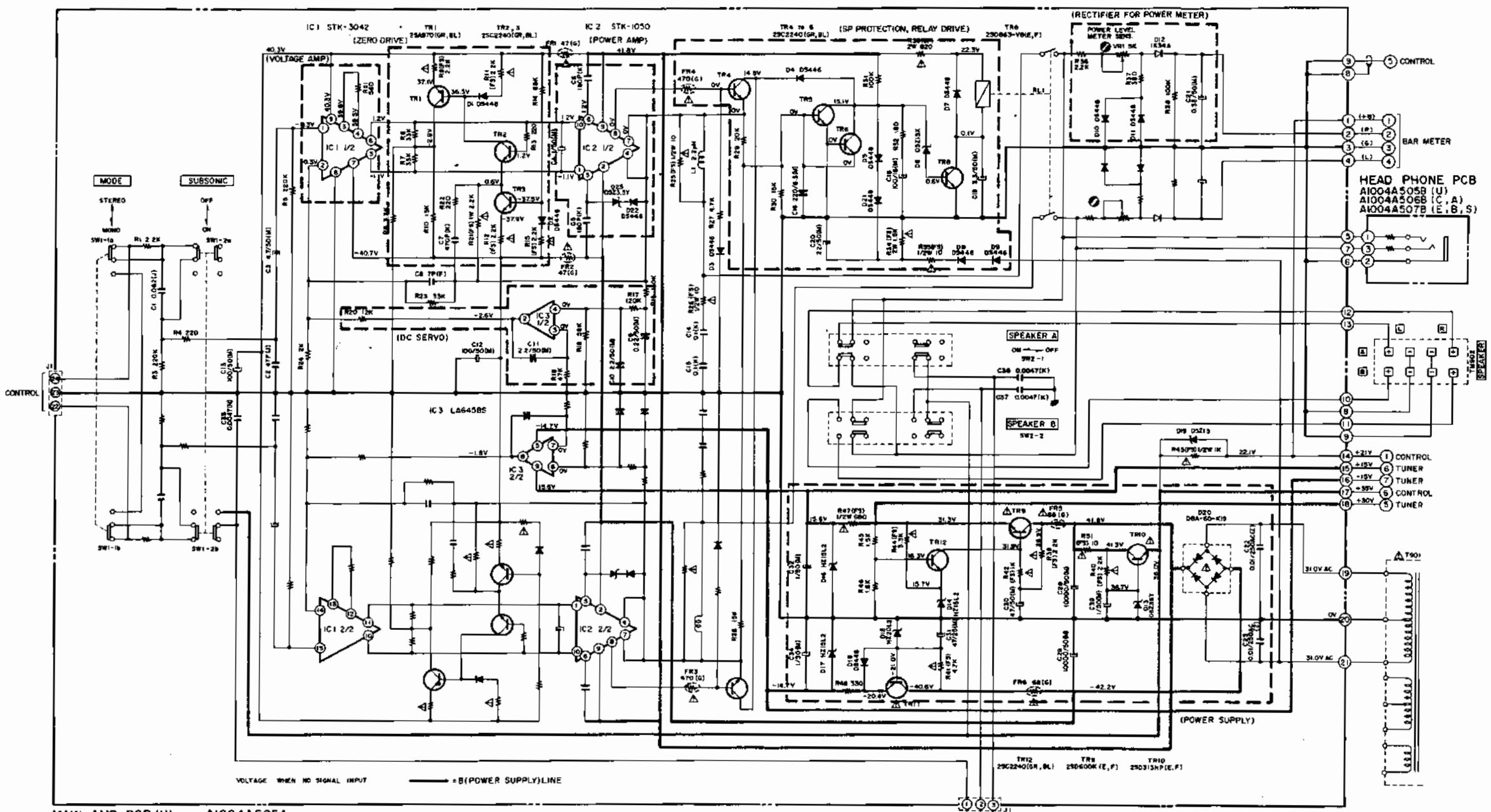

MAIN AMP PCB (U) A1004A505A
 (C,A) A1004A506A
 (E,B,S) A1004A507A

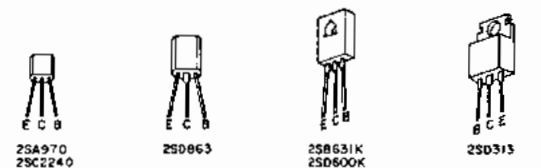

NOTE
 UNLESS OTHERWISE SPECIFIED
 ALL RESISTORS BY OHMS 1/4W (J)
 ALL CAPACITORS IN μ F 50 WV(J)
 (FS) 1 FAIL SAFE RESISTORS

WARNING Δ INDICATES SAFETY CRITICAL COMPONENTS FOR CONTINUED SAFETY.
 REPLACE SAFETY CRITICAL COMPONENTS ONLY WITH MANUFACTURER'S
 RECOMMENDED PARTS
 AVERTISSEMENT Δ IL INDIQUE LES COMPOSANTS CRITIQUES DE SÉCURITÉ.
 POUR MAINTENIR LE DEGRÉ DE SÉCURITÉ DE L'APPAREIL,
 NE REMPLACER QUE DES PIÈCES RECOMMANDÉES PAR LE FABRICANT

(RECEIVER)
AA-R32/L AMP
SCHEMATIC DIAGRAM
 NO.4-2 821030A

AA-R32

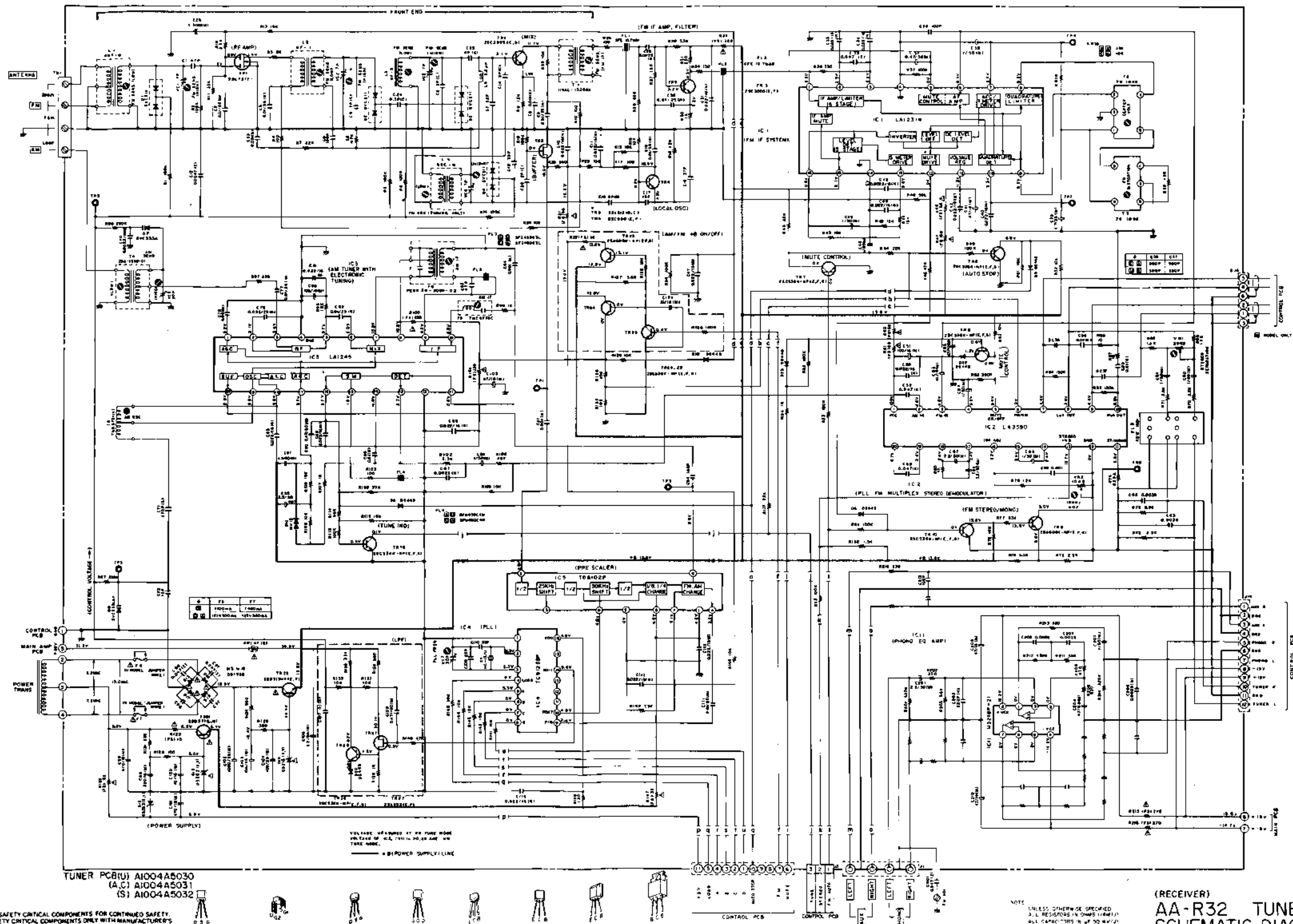

WARNING: Δ INDICATES SAFETY CRITICAL COMPONENTS FOR CONTINUED SAFETY. REPLACE SAFETY CRITICAL COMPONENTS ONLY WITH MANUFACTURER'S RECOMMENDED PARTS.
 AVERTISSEMENT: Δ A. INDIQUE LES COMPOSANTS CRITIQUES DE SÉCURITÉ. POUR MAINTENIR LE DEGRÉ DE SÉCURITÉ DE L'APPAREIL, NE REMPLACER QUE DES PIÈCES RECOMMANDÉES PAR LE FABRICANT.

TUNER PCB(U) A1004A5030
 (A,C) A1004A5031
 (S) A1004A5032

- 25K19
- 25K73
- 25K112
- 25P223
- 25C2596
- 25C2596/HP
- 25C2596/CP
- 25C2596
- 25D071
- 25D213

NOTE: UNLESS OTHERWISE SPECIFIED, ALL RESISTORS IN OHMS (UNLESS OTHERWISE SPECIFIED) AND CAPACITORS IN P.F. (UNLESS OTHERWISE SPECIFIED). ALL PARTS ARE SAFETY RESISTORS.

(RECEIVER)
 AA-R32 TUNER
 SCHEMATIC DIAGRAM
 NO.4-3 821031 A

AA-R32L

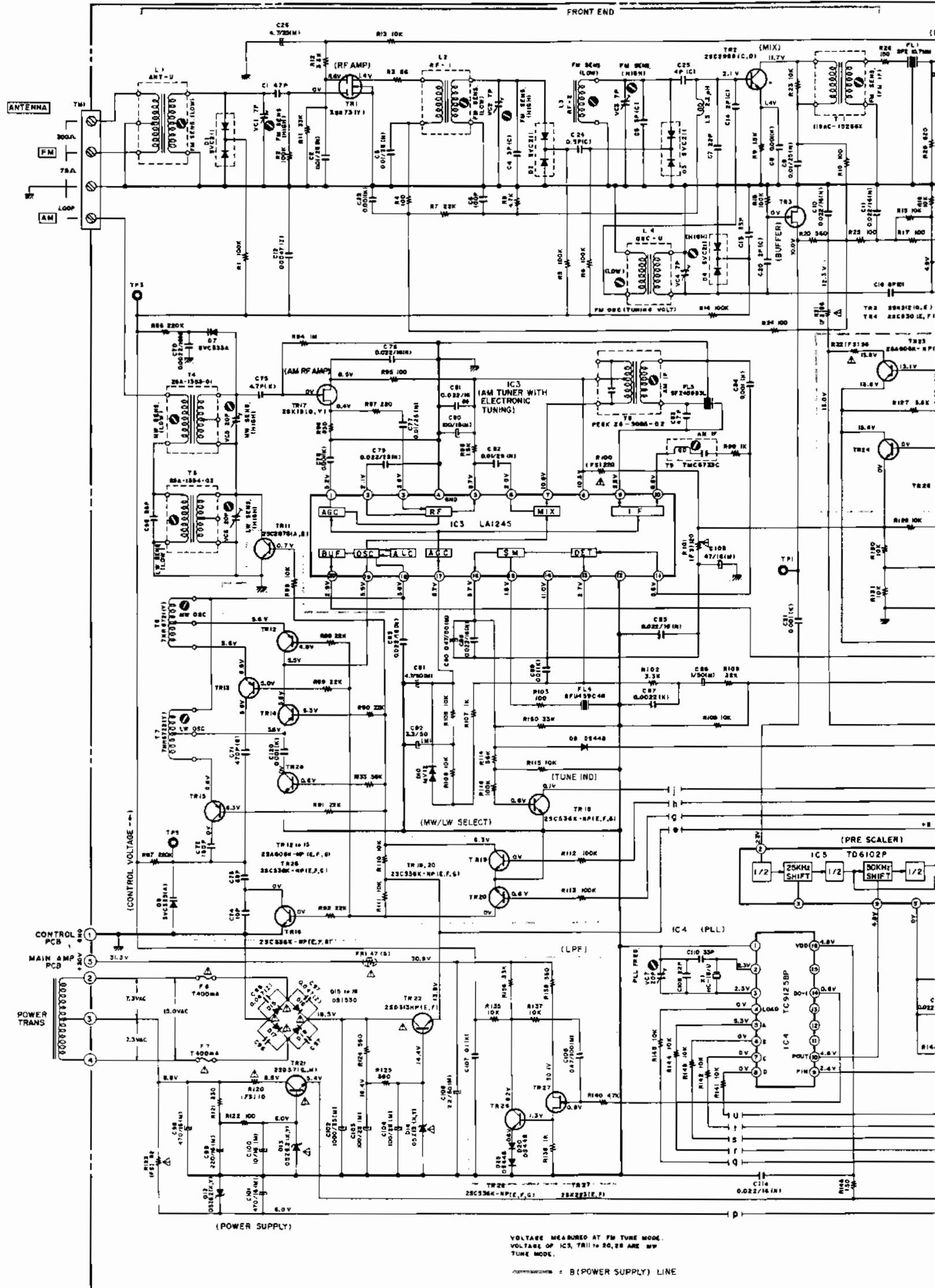

TUNER PCB A1004A5033

WARNING: Δ INDICATES SAFETY CRITICAL COMPONENTS. FOR CONTINUED SAFETY, REPLACE SAFETY CRITICAL COMPONENTS ONLY WITH MANUFACTURER'S RECOMMENDED PARTS.
AVERTISSEMENT: Δ IL INDIQUE LES COMPOSANTS CRITIQUES DE SÉCURITÉ. POUR MAINTENIR LE DEGRÉ DE SÉCURITÉ DE L'APPAREIL, NE REMPLACER QUE DES PIÈCES RECOMMANDÉES PAR LE FABRICANT.



F G H I J K

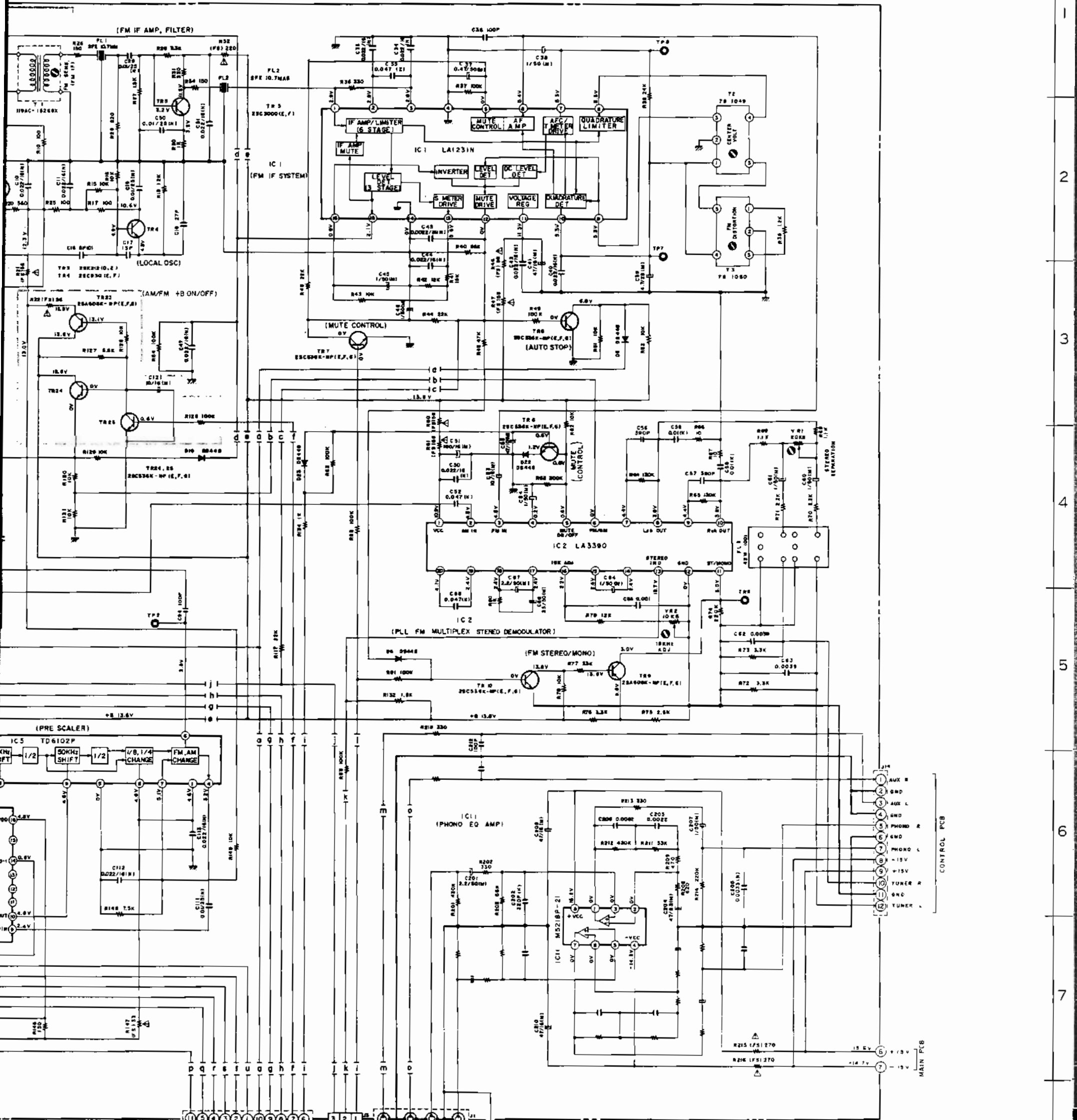

1
2
3
4
5
6
7
8

(RECEIVER)
AA-R32L TUNER
SCHEMATIC DIAGRAM
NO.4-4 821032A

NOTE
UNLESS OTHERWISE SPECIFIED
ALL RESISTORS IN OHMS (1/4W/1)
ALL CAPACITORS IN μ F (50 WV/1)
IFS1: FAIL SAFE RESISTORS

-NP
0800

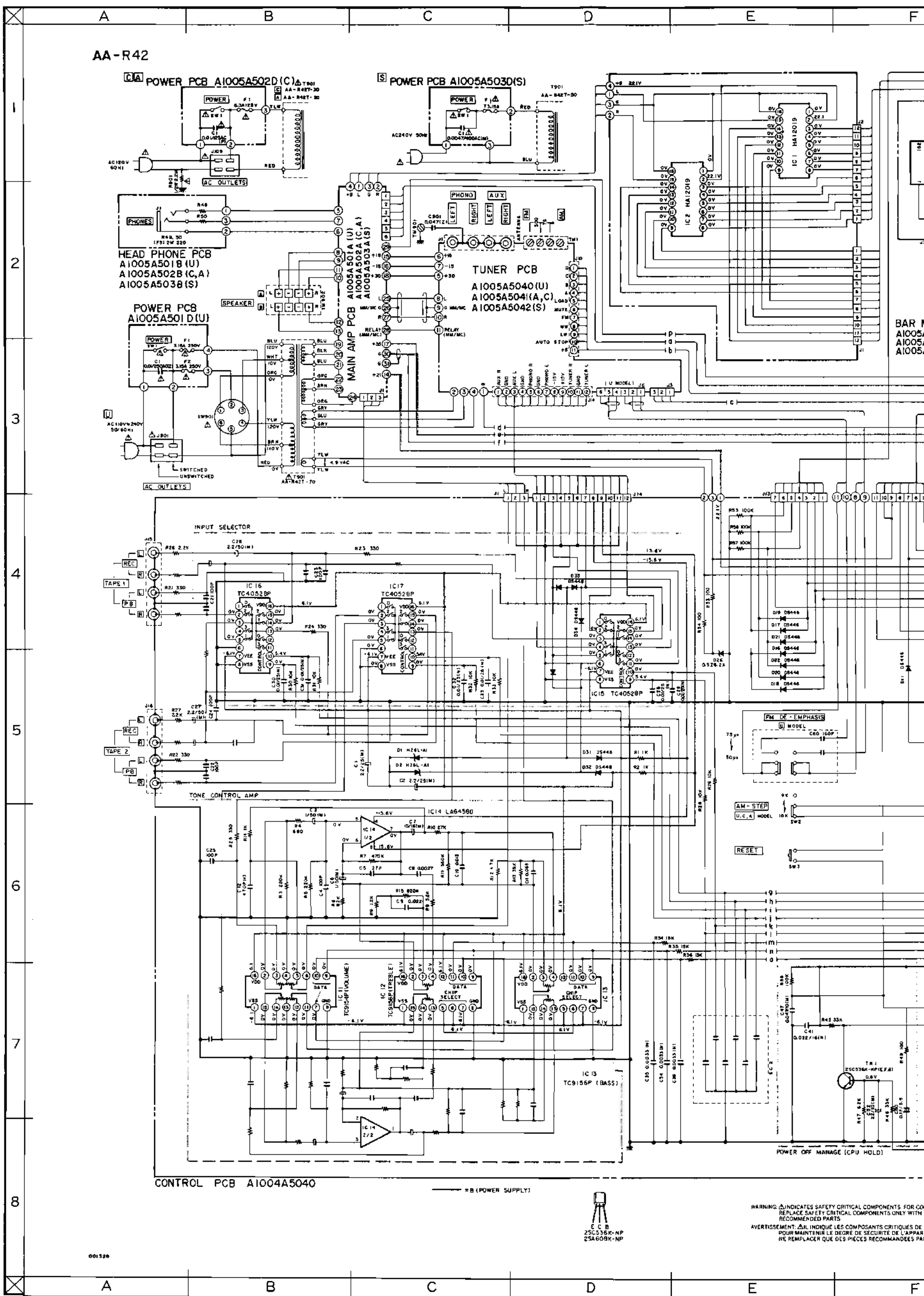

AA-R42

POWER PCB A1005A502D (C)

POWER PCB A1005A503D (S)

HEAD PHONE PCB
A1005A501B (U)
A1005A502B (C,A)
A1005A503B (S)

POWER PCB
A1005A501D (U)

MAIN AMP PCB
A1005A501A (U)
A1005A502A (C,A)
A1005A503A (S)

TUNER PCB
A1005A5040 (U)
A1005A5041 (A,C)
A1005A5042 (S)

INPUT SELECTOR

TONE CONTROL AMP

CONTROL PCB A1004A5040

= B (POWER SUPPLY)

IC B
25C536K-NP
25A608K-NP

WARNING: Δ INDICATES SAFETY CRITICAL COMPONENTS FOR WHICH ONLY THE RECOMMENDED PARTS SHOULD BE USED. REPLACE SAFETY CRITICAL COMPONENTS ONLY WITH RECOMMENDED PARTS.
AVERTISSEMENT: Δ IL INDIQUE LES COMPOSANTS CRITIQUES DE SECURITE DE L'APPAREIL. NE REMPLACEZ QUE DES PIECES RECOMMANDEES PAR LE FABRICATEUR.

001520

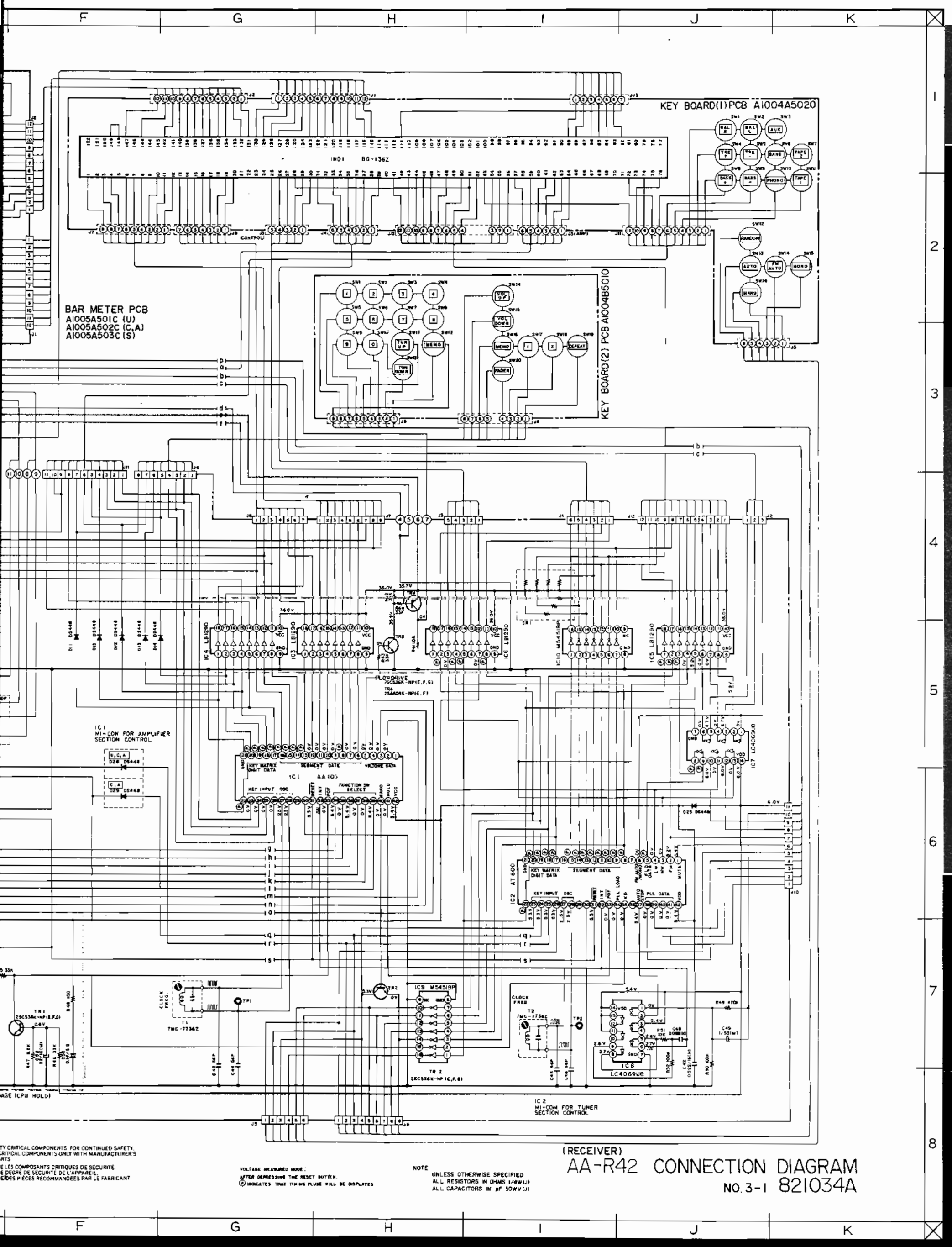

BAR METER PCB
A1005A501C (U)
A1005A502C (C,A)
A1005A503C (S)

KEY BOARD (1) PCB A1004A5020

KEY BOARD (2) PCB A1004B5010

(RECEIVER)
AA-R42 CONNECTION DIAGRAM
NO. 3-1 821034A

VOLTAGE MEASURED HERE:
AFTER DEPRESSING THE RESET BUTT. (C) INDICATES THAT TUNING PLUSE WILL BE DISPLAYED

NOTE
UNLESS OTHERWISE SPECIFIED
ALL RESISTORS IN OHMS (1/4W/1%)
ALL CAPACITORS IN pF (50WV/1%)

CRITICAL COMPONENTS FOR CONTINUED SAFETY.
CRITICAL COMPONENTS ONLY WITH MANUFACTURER'S
PARTS
LES COMPOSANTS CRITIQUES DE SÉCURITÉ
SEULS LES PIÈCES RECOMMANDÉES PAR LE FABRICANT

