

# SERVICE MANUAL

**AKAI TAPE DECK**

**MODEL 250D**



### TABLE OF CONTENTS

I	SPECIFICATIONS .....	2
II	MEASURING METHODS .....	3
III	CONTROL LOCATIONS .....	5
IV	TRANSPORT MECHANISM .....	6
V	MECHANISM ADJUSTMENT .....	8
VI	AMPLIFIER ADJUSTMENT .....	12
VII	COMPOSITE VIEWS OF COMPONENTS .....	14
VIII	TROUBLE SHOOTING CHART .....	19
IX	SCHEMATIC DIAGRAM	

When placing order for parts, please use Separate  
**PARTS LIST** or **PRICE LIST FOR PARTS**.

# I. SPECIFICATIONS

**STYLE** : Portable  
**WEIGHT** : 44 lbs (20 kg)  
**DIMENSIONS** : 17.1" x 18.1" x 10.1"  
 (435 mm x 460 mm x 260 mm)  
**POWER SUPPLY** : AC 100 to 240 V ; 50/60 Hz  
**RECORDING SYSTEM**  
 : 4-track stereo, monaural recording system.  
**PLAYBACK SYSTEM**  
 : 4-track stereo, monaural playback system.  
**TAPE SPEED** : 1-7/8, 3-3/4, and 7-1/2 ips.  
**TAPE SPEED DEVIATION**  
 : Within +1.0%, -0.5% at 7-1/2 ips,  
 Within  $\pm 1.0\%$  at 3-3/4 and 1-7/8 ips.  
**WOW AND FLUTTER**  
 (Playback only) : Less than 0.12% r.m.s. at 7-1/2 ips.  
 Less than 0.18% r.m.s. at 3-3/4 ips.  
 Less than 0.3% r.m.s. at 1-7/8 ips.  
**FREQUENCY RESPONSE**  
 : 30 to 20,000 Hz  $\pm 3$  db at 7-1/2 ips.  
 30 to 12,000 Hz  $\pm 3$  db at 3-3/4 ips.  
 50 to 5,000 Hz  $\pm 4$  db at 1-7/8 ips.  
**SIGNAL TO NOISE RATIO**  
 : Better than 48 db at 7-1/2 and 3-3/4 ips.  
 Better than 45 db at 1-7/8 ips.  
**DISTORTION** : Within 2% at 7-1/2 ips.  
 Within 3% at 3-3/4 and 1-7/8 ips.  
 (at line output, 1,000 Hz OVU Recording and Playback)  
**CROSSTALK** : Less than -60 db (Monaural)  
 Less than -45 db (Stereo)  
**ERASE RATIO** : Less than -70 db.  
**INSULATION RESISTANCE**  
 : 500 V AC for more than one minute duration.  
**LINE OUTPUT** : 1.23 V (+4 db), Output impedance ... 100 Ohms.  
 Required load impedance more than 25 K ohms  
**DIN OUTPUT** : 0.4 V, Output impedance ... 10 K ohms.  
 Required load impedance more than 50 K ohms.  
**LINE INPUT** : Above 70 mV.  
 Impedance ..... 200 K ohms.  
**DIN INPUT** : High ..... Above 50 mV  
 Impedance ..... 75 K ohms.  
 Low ..... Above 7 mV  
 Impedance ..... 67 K ohms.  
**MIC INPUT** : Above 0.5 mV, Impedance ... 10 K ohms.  
**FAST FORWARD TIME**  
 : 88 seconds for a full 1,200 foot tape at 50 Hz., 77 seconds at 60 Hz.  
**REWIND TIME** : 81 seconds at 50 Hz., 68 seconds at 60 Hz for a full 1,200 foot tape.

**MOTORS**  
**CAPSTAN MOTOR**  
 : Servo-Control 3-speed motor.  
 Condenser Capacity 3.5  $\mu$ F (50 Hz).  
 2.5  $\mu$ F (60 Hz).  
 Revolutions ; 909, 454.5, and 227.5 r.p.m..  
**REEL MOTOR**  
 : Two 6-pole eddy current outer-rotor motors.  
 Revolutions ; 930 r.p.m. at 50 Hz., 100 V.  
 1120 r.p.m. at 60 Hz., 110 V.  
**HEADS**  
**PLAYBACK HEAD**  
 : In-line 4-track stereo  
 Impedance ... 5,000 Ohms at 1,000 Hz.  
 Cap ..... 1/1,000 mm.  
**RECORDING HEAD**  
 : In-line 4-track stereo and monaural  
 Impedance .... 125 Ohms at 1,000 Hz.  
 Gap ..... 4/1,000 mm.  
**ERASE HEAD** : In-line 4-track stereo.  
 Impedance ..... 200 Ohms at 100 kHz.  
**RECORDING LEVEL INDICATOR**  
 : Two vertical indication VU Meters  
**TRANSISTORS USED**  
 2SC871 (E) (F) or 2SC458LG (C) ... 8  
 2SC968 (3) (4) ..... 6  
 2SC945 (Q) (R) ..... 4  
 2SC771 (2) (3) red ..... 2  
 2SC458LG (B) (C) ..... 2  
 2SC711 (D) (E) or 2SC536 (E) (F) ... 6  
 2SC945 (R) ..... 2  
 2SA564 (R) (S) ..... 3  
 2SC711 (G) (F) or 2SC536 (G) (H) ... 1  
 2SD234 (Y) ..... 2  
 2SC1013 ..... 1  
 IC EHD AA072D ..... 2  
**DIODES USED** : 4 10D4                    2 10DC-1 (red)  
 10 10D1                    2 10DC-1 (blk)  
 1 RD9A                    1 WG1010A  
 1 1N34A

## II. MEASURING METHOD

### TAPE SPEED DEVIATION

1. Method involving use of pre-recorded tape  
Playback a tape pre-recorded at 1,000 Hz ( $\pm 0.1\%$ ) on the recorder to be tested. Connect the appropriate output to a frequency counter meter in order to measure the tape speed deviation.
2. Method involving use of timing tape (designed for tape speed measurement)  
This method utilizes a timing tape marked at intervals of 7-1/2". The running time of over 60 marked sections of the tape is measured in order to calculate the tape speed deviation. In applying this method, however, it should be kept in mind that timing tape stretch or contract measurement is inevitable, so that it is necessary to measure the total length of the tape in advance.

### WOW AND FLUTTER

Playback the 3,000 Hz pre-recorded tape of which the wow and flutter level is guaranteed to be smaller than 0.07% for measurement by means of a wow meter. It is also possible for a 3,000 Hz sine wave to be recorded and played back for measurement by means of a wow meter. In this case, however, the wow meter indicates a value as much as twice the value given in the specifications.

### FREQUENCY RESPONSE

#### RECORD :

- 1) Give a sine wave of 1,000 Hz to the Line Input of the recorder to be tested through an attenuator from an audio frequency generator.
- 2) Set the Monitor Switch to "SOURCE" position and adjust the line input volume so that the VU Meter needle indicates "0" VU.
- 3) Set the TAPE SPEED SELECTOR to 7-1/2" or 3-3/4" position.
- 4) Under the condition described in (2), lower the input level 20 db by means of the attenuator.
- 5) Record the spot frequency in the range of 30 Hz to 20,000 Hz from the audio frequency generator.

#### PLAYBACK :

- 6) Set the Monitor Switch to "TAPE" position.
- 7) Connect a Vacuum Tube Volt Meter to the Line Output Jack. (VTVM with millivolt scale.)
- 8) Playback the recorded tape.
- 9) Playback the recorded spot frequencies and make a memo of output level and plot the value on a graph.

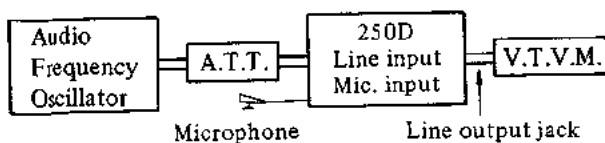

### TOTAL HARMONIC DISTORTION FACTOR

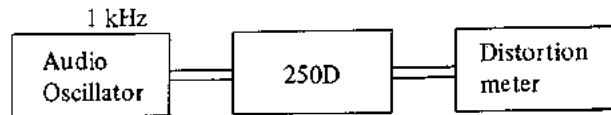

Connect the measuring instrument as shown above, and record the 1,000 Hz sine wave at "0" VU. Playback the resulting signal and measure the overall distortion factor. Measure the noise level of the tape recorder with the tape removed; connect the audio oscillator directly to the distortion meter for measurement of the distortion factor of the oscillator.

The required distortion factor may be obtained from the results of the above measurement by the following formula :

$$d_0 = d - d_1 - d_2$$

Where,  $d_0$  = Required

$d$  = Overall distortion factor

$d_1$  = Noise level

$d_2$  = Distortion factor of the oscillator

(Note : New tape of particularly good quality should be used for measurement of the distortion factor.)

### SIGNAL TO NOISE RATIO

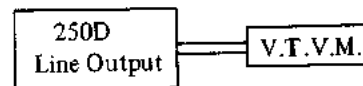

Set the Tape Speed Selector to "7-1/2 ips" position and playback a tape containing a 250 Hz sine wave recorded at "0" VU level on a standard recorder. Connect a V.T.V.M. to the line output jack of the recorder and measure its output. Then remove the tape and measure the noise level under the same condition. Convert into decibels each of the measured values.

---

**CROSSTALK (Crosstalk between the tracks)**

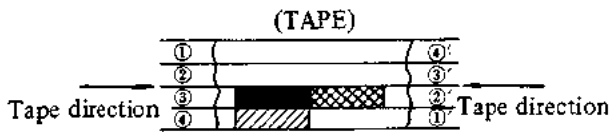

As shown in the figure, first record a 1,000 Hz sine wave on track No. 3 at +3 VU level. Next, remove the 1,000 Hz input signal and record under a non-input condition. Then, playback the tape on track No. 3 and No. 1 (reversed condition of tape) through the 1,000 Hz B.P.F. (Band Pass Filter, Sensitivity . . . 1 : 1) and obtain a ratio between the two from the following formula.

$$C = 20 \log \frac{E_0}{E_2 - E_1} \text{ (db)}$$

- C = Desired crosstalk ratio (db)
- E<sub>0</sub> = 1,000 Hz signal output level
- E<sub>2</sub> = 1,000 Hz crosstalk output level
- E<sub>1</sub> = Non-input signal record level

### III. CONTROL LOCATIONS

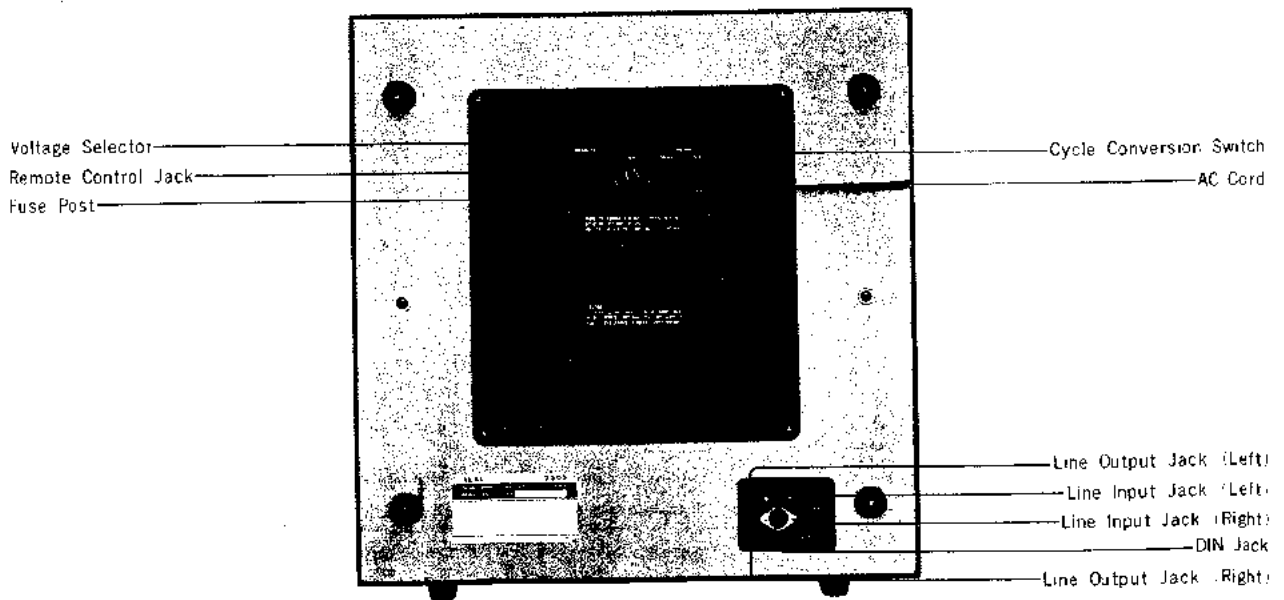
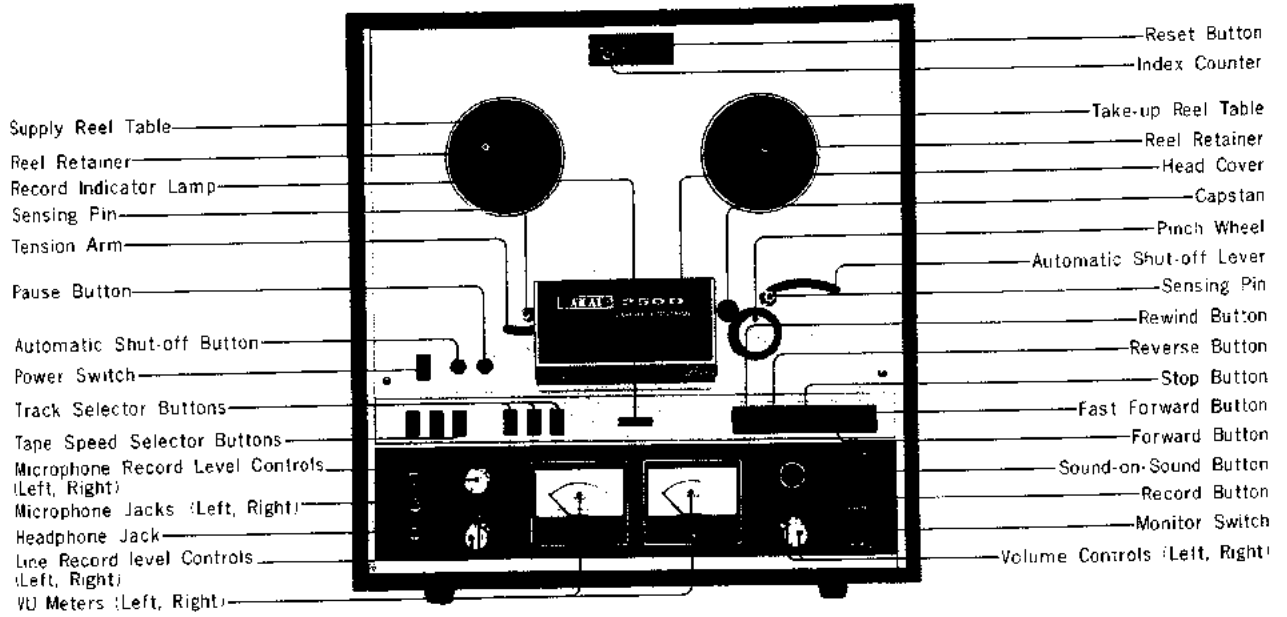

# IV. TRANSPORT MECHANISM

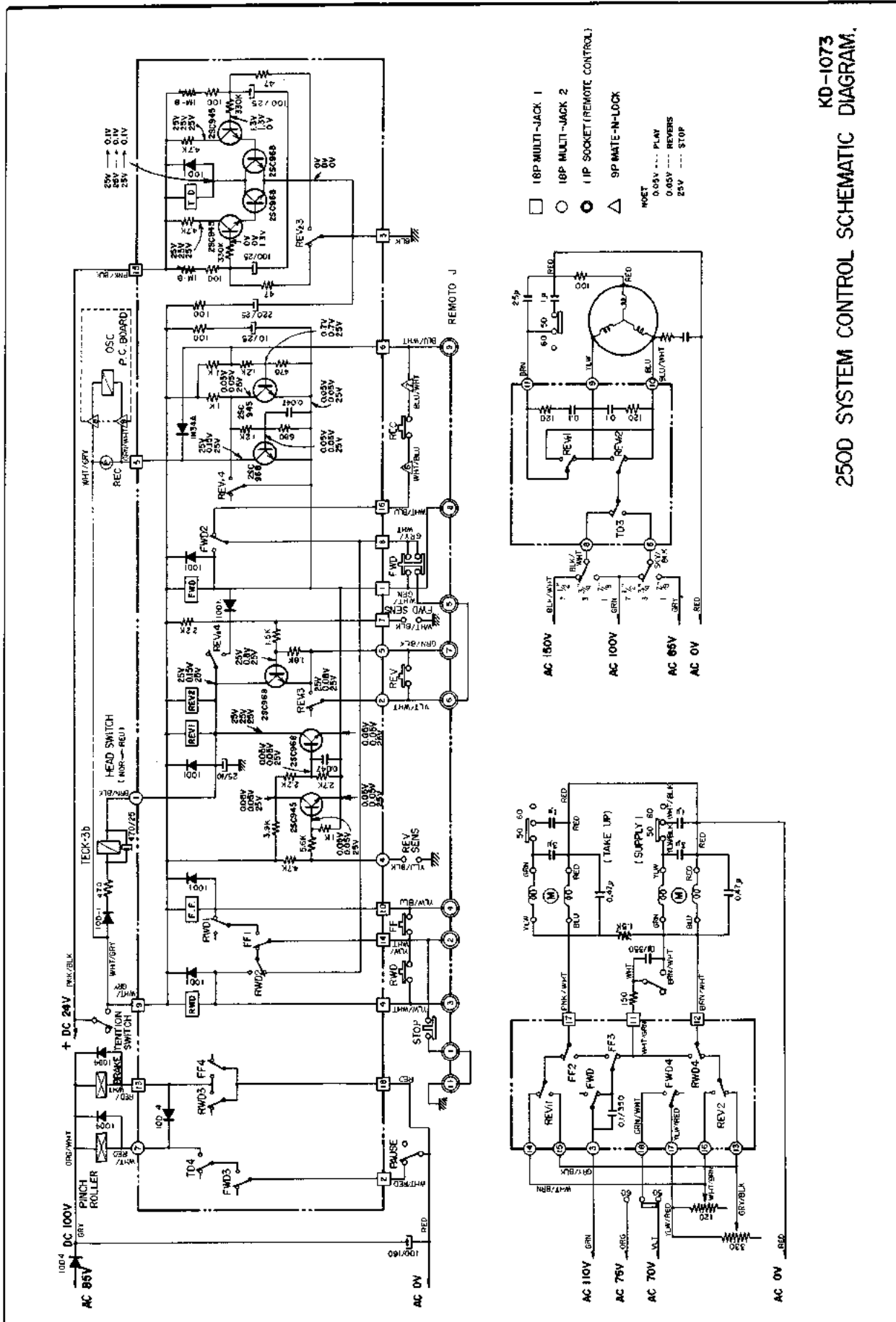

KD-1073  
2500 SYSTEM CONTROL SCHEMATIC DIAGRAM.

---

**1. SUPPLY VOLTAGE OF BOTH TORQUE  
MOTORS DURING RECORDING/PLAYBACK**

	SUPPLY	TAKE-UP
Normal Play	32 V (50 to 60 gr)	55 V (160 gr)
Reverse	55 V (160 gr)	32 V (50 to 60 gr)
RW-FF	100 V (550 gr)	100 V (550 gr)

**2. PINCH ROLLER PRESSURE**

Proper pinch roller pressure is 2 Kg ( $\pm 100$  gr).



## V. MECHANISM ADJUSTMENT

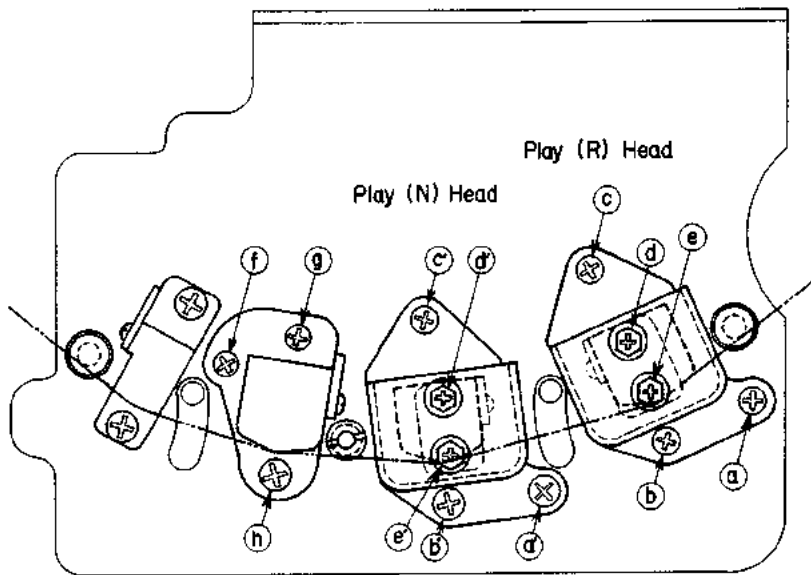

Fig. 5-1

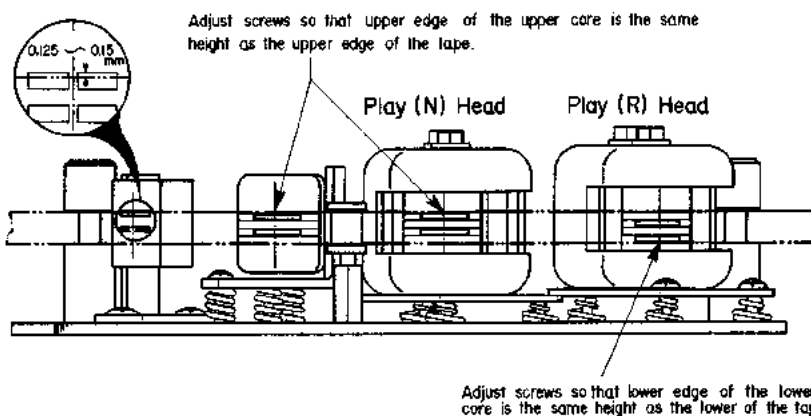

Fig. 5-2

### 1. ADJUSTMENT OF HEAD HEIGHT (See Figures 1 and 2)

- 1) To adjust Play (N) Head height, turn screws (a') (b') and (c') during normal play so that the upper edge of the upper core of the Play (N) Head is the same height as the upper edge of the tape.
- 2) To adjust Play (R) Head height, turn screws (a) (b) and (c) so that the lower edge of the lower core of the Play (R) Head is the same height as the lower edge of the tape.
- 3) To adjust Recording Head height, turn screws (f) (g) and (h) so that the upper edge of the upper core of the Recording Head is the same height as the upper edge of the tape.
- 4) Erasing Head  
The upper edge of the upper core of the erase head must be 0.125 to 0.15 mm higher than the upper edge of the tape. In adjusting head height, make sure that the front of the head is at right angles to the chassis and that the upper and lower part of the head firmly contacts the tape.

### 2. ADJUSTMENT OF AZIMUTH ALIGNMENT

- 1) Playback Head  
Use a pre-recorded tape (16 kHz, 7-1/2 ips), and connect a high sensitivity V.T.V.M. to the line output jack. Adjust screws (a) (b) and (a') (b') so that the line output voltage is maximum.
- 2) Recording Head  
After completing playback head azimuth alignment, record a 16 kHz signal at 7-1/2 ips and adjust screws (f) and (h) so that the line output voltage is maximum.

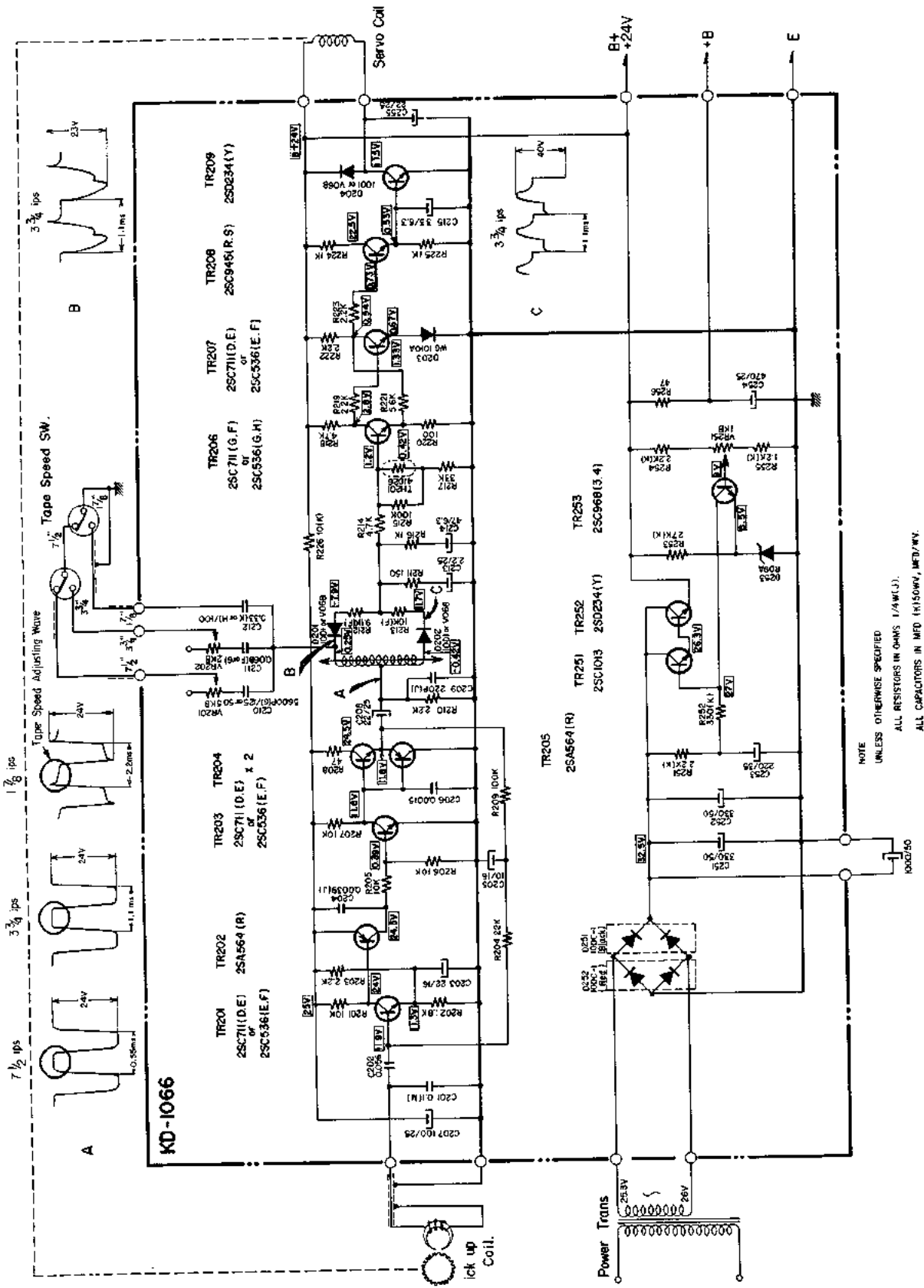

250D SERVO SCHEMATIC DIAGRAM No.4 - 1

Fig. 5-3

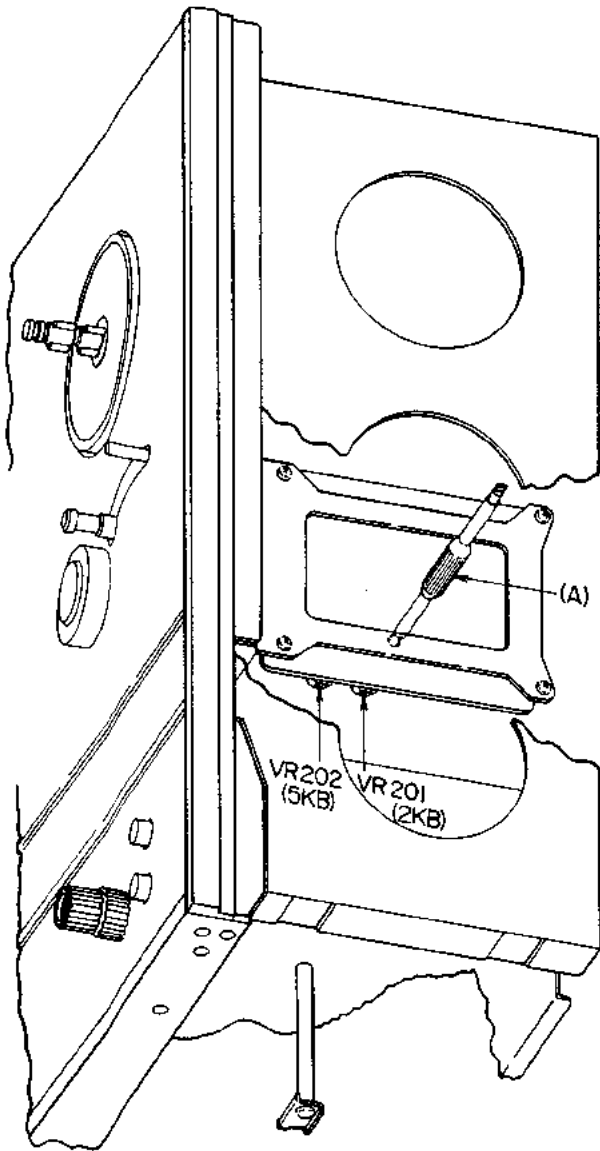

### 3. TAPE SPEED ADJUSTMENT METHODS (Servo-Motor Circuit Adjustment)

#### MEASURING METHOD INVOLVING USE OF PRE-RECORDED TAPE

- 1) Set Speed Selector to 1-7/8 ips and playback a 1 kHz pre-recorded tape.
- 2) Adjust L 201 transformer core so that the Frequency Counter Indication is 250 Hz  $\pm$ 1% (see Fig. 5-4, point A).
- 3) Set Speed Selector to 3-3/4 ips.
- 4) Adjust VR 201 (2 KB) so that the Frequency Counter indication is 500 Hz  $\pm$ 1%.
- 5) Set Speed Selector to 7-1/2 ips.
- 6) Adjust VR 202 (5 KB) so that the Frequency Counter indication is 1,000 Hz  $\pm$ 1%.

Motor revolutions at each speed should be as follows :

7-1/2 ips	909 r.p.m.
3-3/4 ips	454.5 r.p.m.
1-7/8 ips	227.25 r.p.m.

In case a Frequency Counter is not used, connect an oscilloscope to the center point of L 201 and measure the respective waveforms (Ref. to Fig. 5-3).

Fig. 5-4

**4. REEL HEIGHT ADJUSTMENT (SEE DIAGRAM ILLUSTRATION)**  
Loosen Reel Table Screws and regulate height.

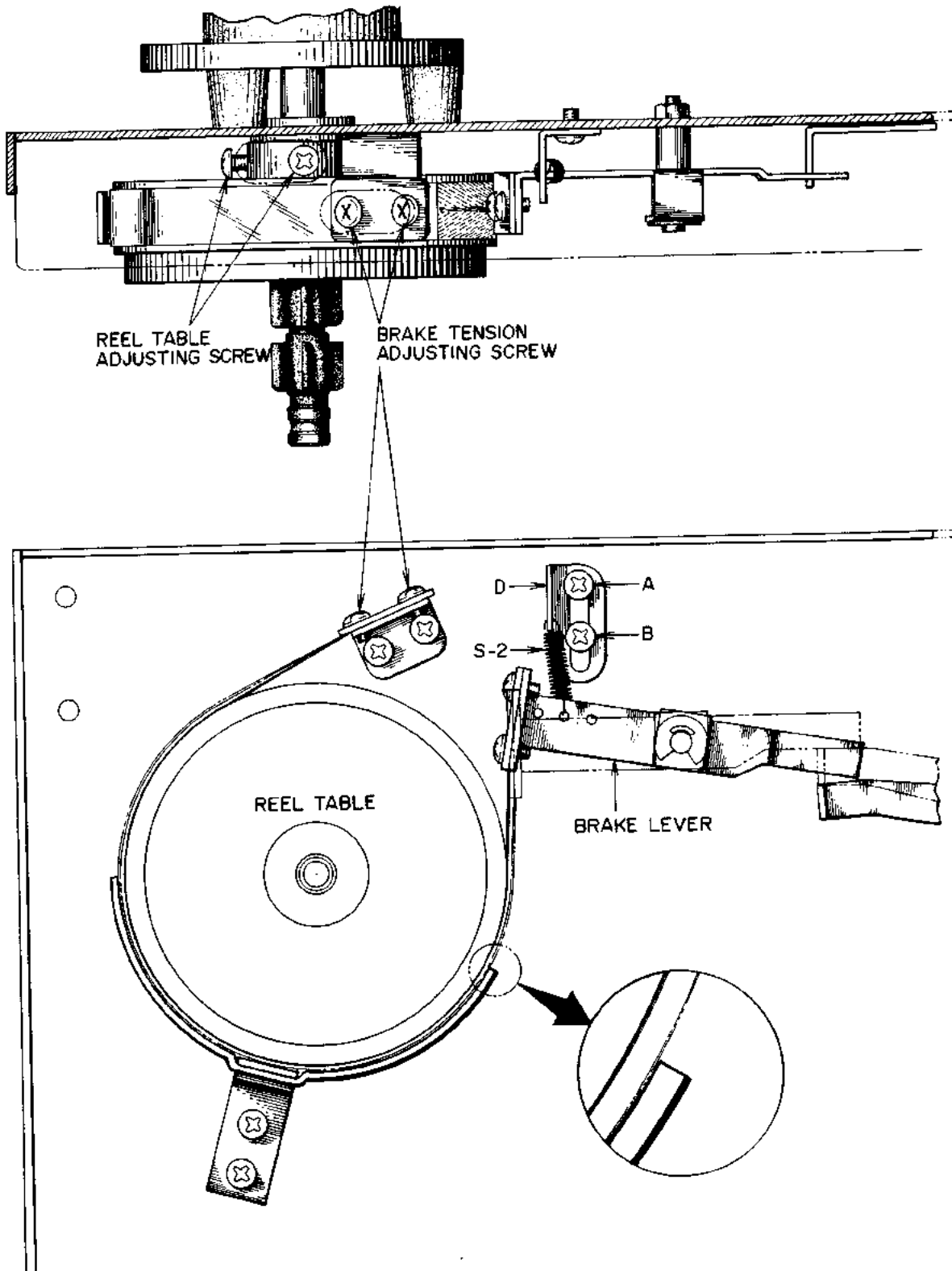

Fig. 5-5

## VI. AMPLIFIER ADJUSTMENT

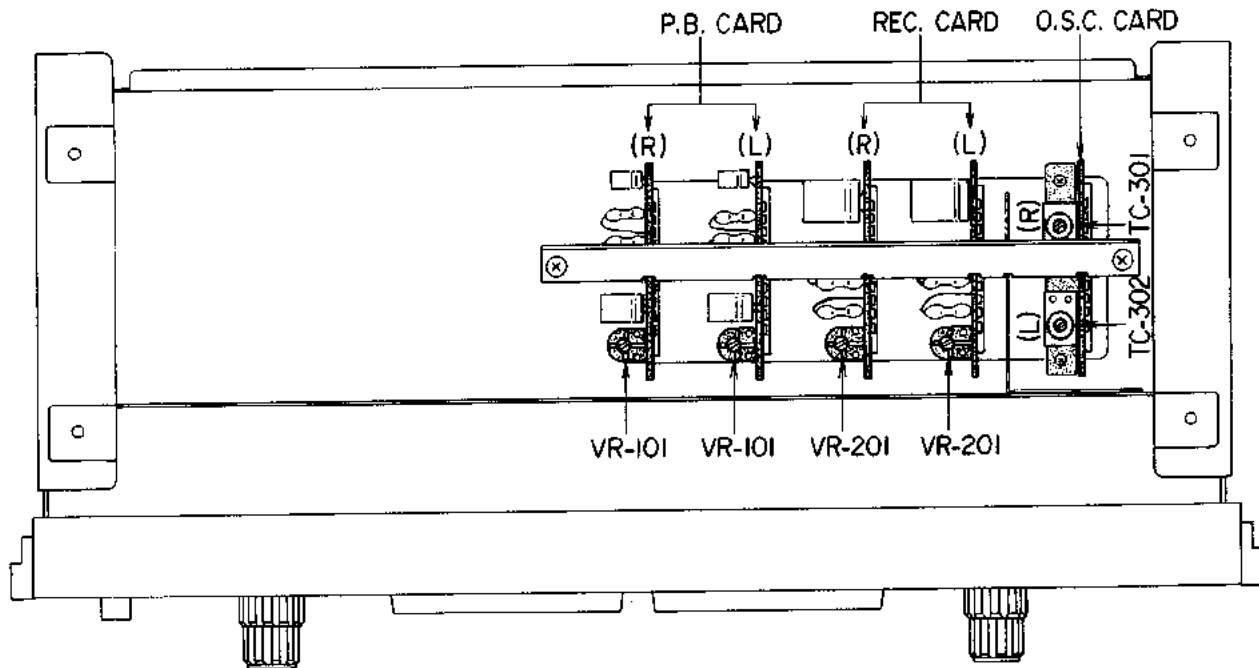

Fig. 6-1

### 1. PLAYBACK OUTPUT LEVEL (PRE-AMPLIFIER) ADJUSTMENT

- a) Connect a high sensitivity V.T.V.M. to the Line Output Jack.
- b) Set the Tape Speed Selector Switch to the "7-1/2" position.
- c) Playback a 250 Hz pre-recorded tape.
- d) Adjust the VR 101 (semi-fixed resistor 20 K-B, Fig. 6-1) of the pre-amplifier so that Line Output Voltage indicates 1.228 V (+4 dbm).

### 2. ADJUSTMENT OF RECORDING LEVEL

Recording Amplifier Adjustment should be made only after Head Adjustment (vertical and horizontal azimuth) and Playback Amplifier Adjustments have been made.

- 1) As shown in Fig. 6-2, connect an Audio Oscillator and Attenuator to the Line Input. Connect a High-sensitivity V.T.V.M. to the Line Output.
- 2) Set Tape Speed Selector to "7-1/2".
- 3) Load a blank test tape (Scotch No. 150) on the tape recorder and set the Monitor Switch to "SOURCE" position.
- 4) Supply a 1000 Hz signal from the audio oscillator to the Line Input, and adjust the volume control so that the VU Meter indicates "0" VU (intermediate between red and black).
- 5) Record the tape and check playback to see whether the VU Meter indicates "0" VU.
- 6) If the VU Meter fails to register "0" VU during playback, repeat recording and adjust the line volume controls so that meter indicates "0" VU during playback. (Monitor Switch should be at TAPE position.)
- 7) With tape recorder at STOP mode, set the Monitor Switch to SOURCE position and adjust semi-fixed resistor VR 201 (20 KB) on the recording pre-amp until the meter indicates "0" VU.

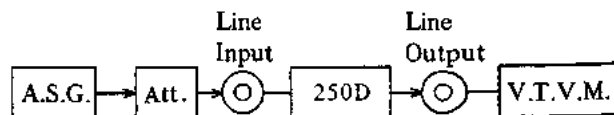
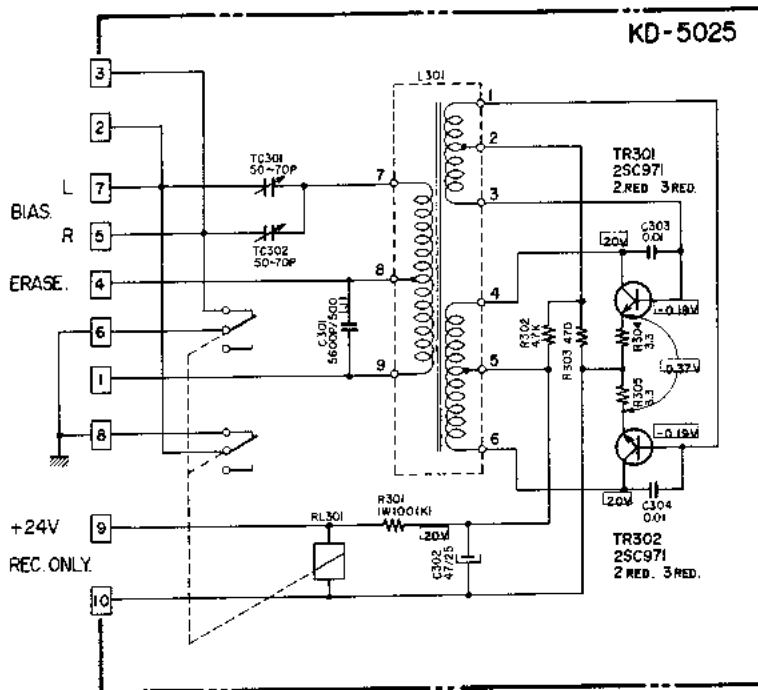

Fig. 6-2



NOTE:  
UNLESS OTHERWISE SPECIFIED:  
ALL RESISTORS IN OHMS (1/4W/1%)  
ALL CAPACITORS IN MFD (1/2) 50WV, MFD/WV.

250D O.S.C. SCHEMATIC DIAGRAM No.4 - 3

Fig. 6-3

### 3. ADJUSTMENT OF RECORDING BIAS FREQUENCY AND VOLTAGE

Proper Bias Frequency of the 250D is 95 to 105 kHz. The frequency can be adjusted by converting the value of Condenser C-301 (5600 p). Proper Bias Voltage is 14 to 16 V.

The voltage can be adjusted by turning TC 301 and TC 302 (50 to 70 p) in the bias oscillator circuit. (To obtain optimum adjustments of bias response and distortion factor, left and right is not always the same).

### 4. BIAS ADJUSTMENT (Frequency Response Adjustment)

- 1) Follow the Frequency Response Measuring Method.
- 2) Record under a 1 kHz and a 10 kHz signal level at 7-1/2 ips (-16 db from 0 VU).
- 3) Check the output levels of both signals on the V.T.V.M. and adjust the Bias adjusting valuable capacitor TC 301 and TC 302 so that both output frequency levels are the same.

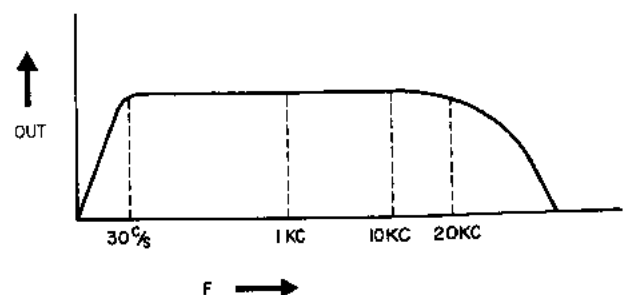
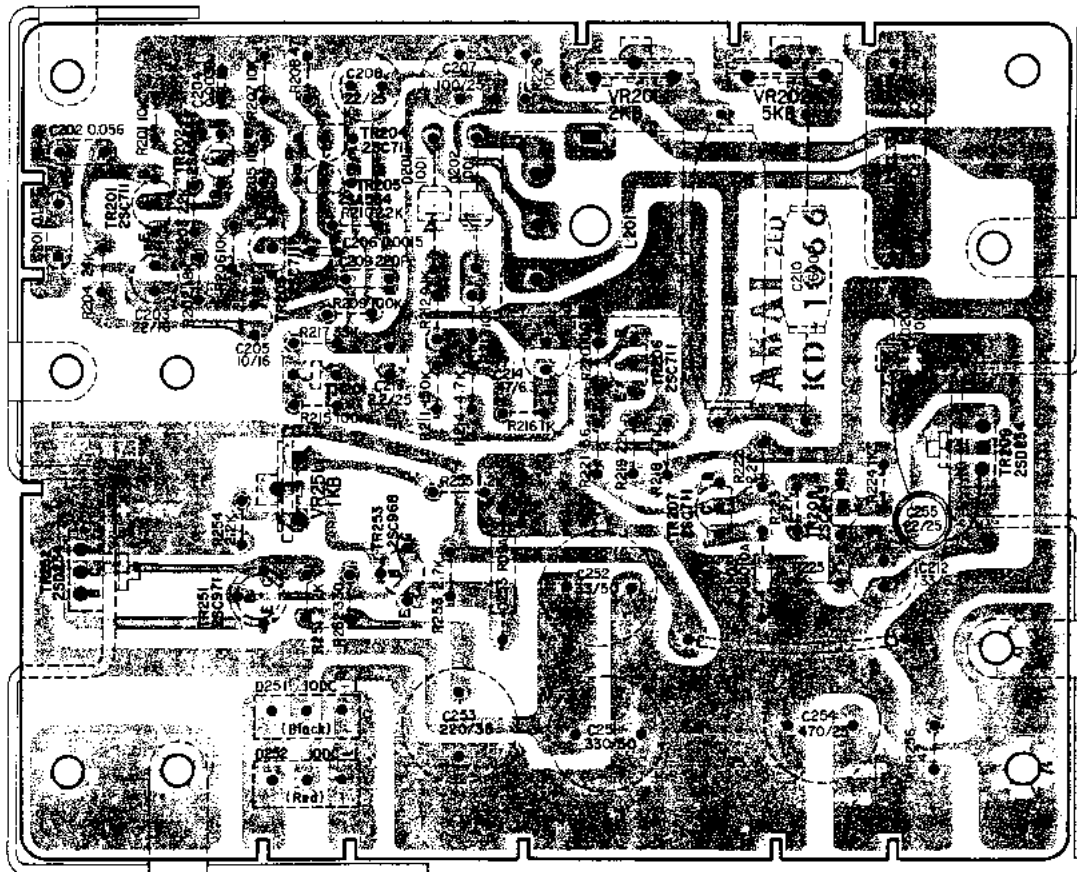

Fig. 6-4

## VII. COMPOSITE VIEWS OF COMPONENT

### SERVOMOTOR CONTROL P.C. BOARD (KD-1066)



### SYSTEM CONTROL P.C. BOARD (KD 1060 A)

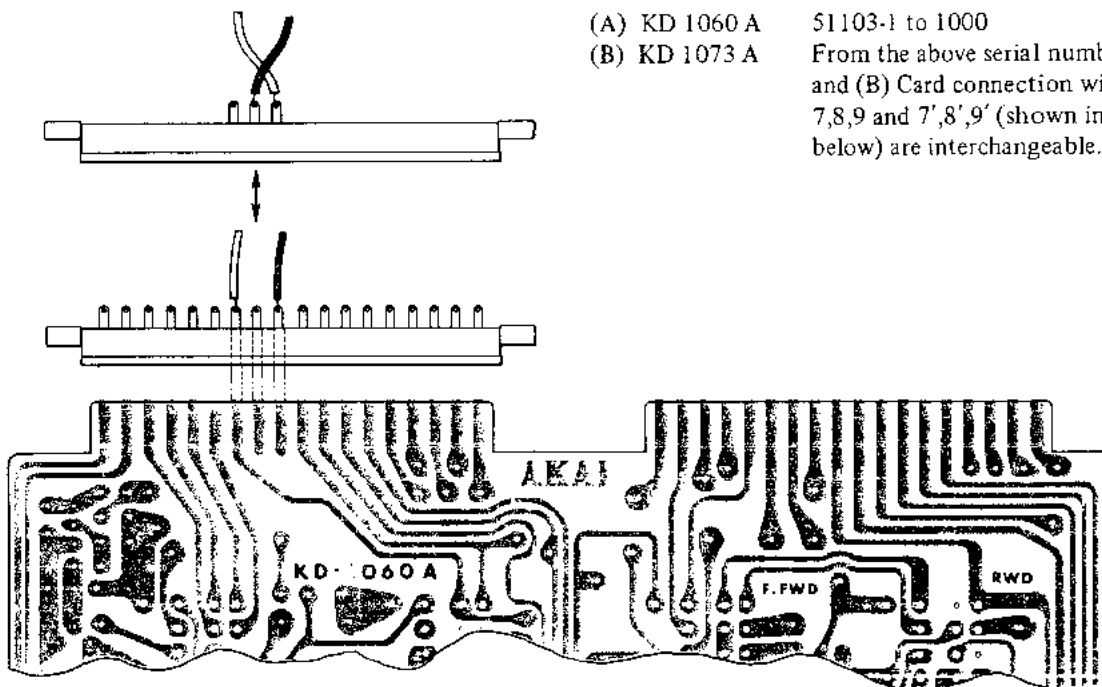

- (A) KD 1060 A 51103-1 to 1000  
 (B) KD 1073 A From the above serial numbers, (A) and (B) Card connection wires 7,8,9 and 7',8',9' (shown in figs. below) are interchangeable.

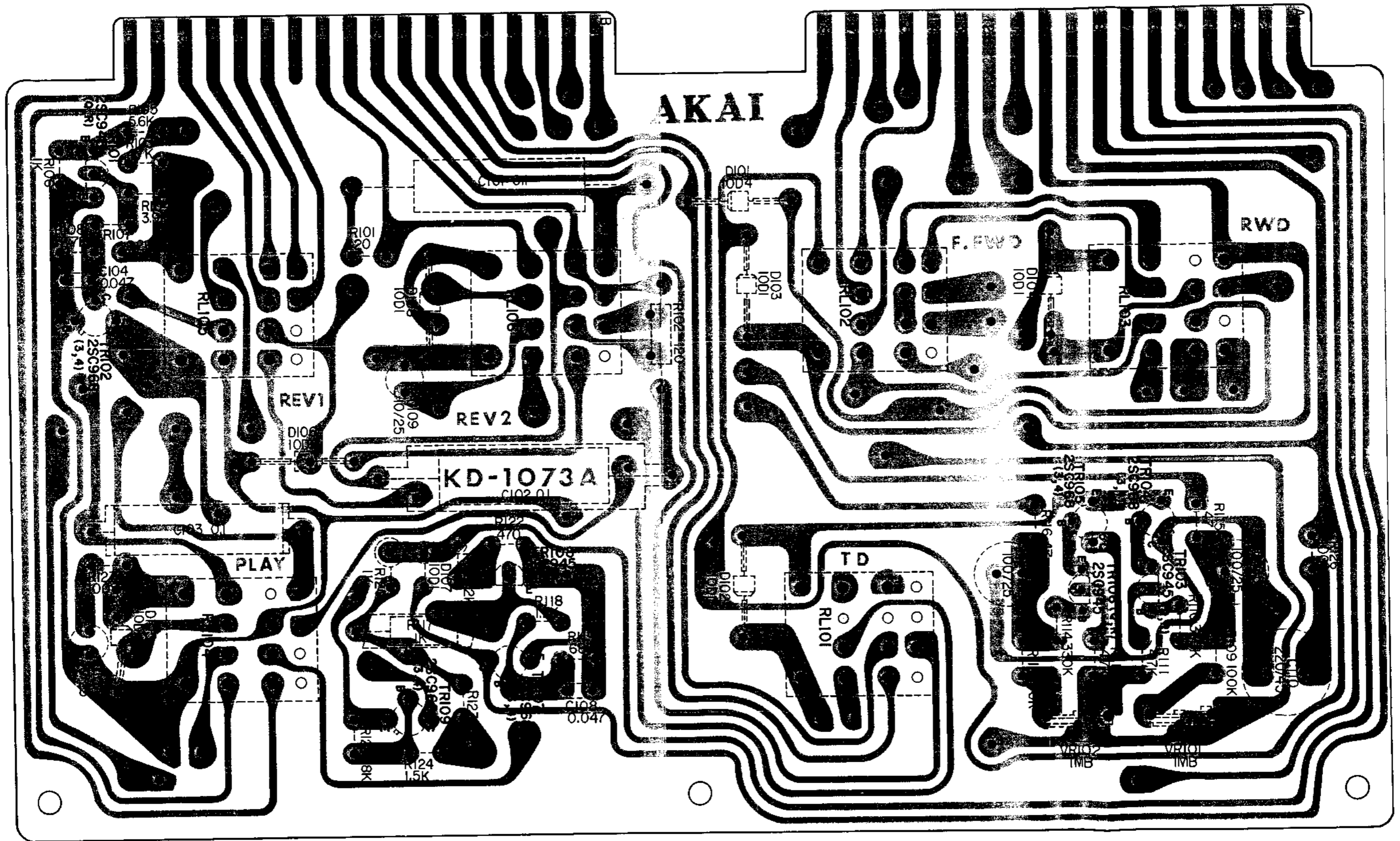





PRE-AMP. CHASSIS P.C. BOARD (KD-5027)

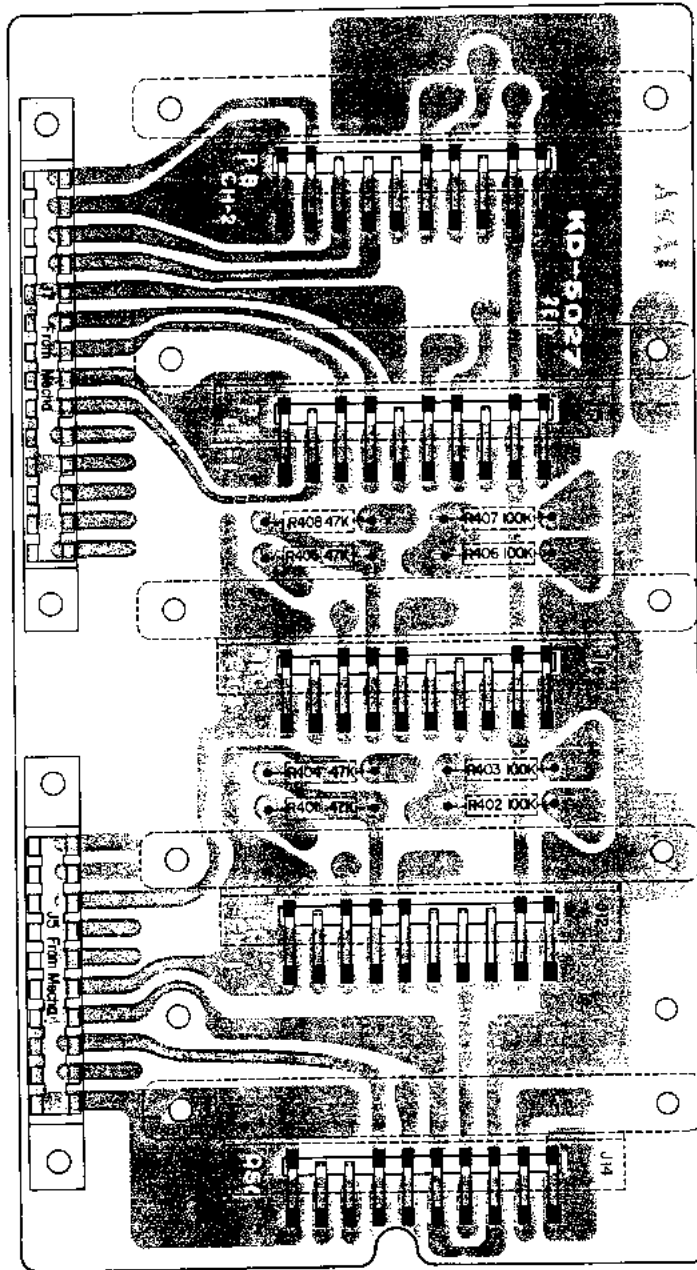

HEAD CHANGING P.C. BOARD (KD-0037)

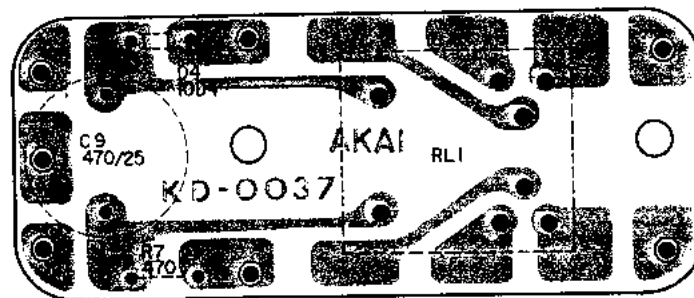

## VIII. TROUBLE SHOOTING CHART

### SECTION A TROUBLE WITH TRANSPORT MECHANISM

Symptom	Remarks	
Capstan does not rotate even with Power Switch turned on.	VU Meter lamp does not light (No Power Source). VU Meter lamp lights.	Check position of Automatic Shut-Off Switch (Set to "Off" position). Motor or Servo-Circuit (see Servo-Circuit Trouble Shooting). Check contact point of Relay RV 2 and TD.
Capstan rotates during play-back mode, but reels do not rotate.	Check R <sub>1</sub> (120 Ω 30 W) R <sub>2</sub> (330 Ω 30 W) and connection wires. Check each relay (Fwd, Rev, Rwd).	Replace broken wire. Repair faulty contact. Repair faulty contact point. Repair or replace relay.
Faulty reverse operation.	Does not reverse from forward mode.  Does not forward from reverse mode.	Check Reverse Sensing Pole. Check TR-101 (2SC945), 102 (2SC968), 109 (2SC968). Check Relay Rev 1. Rev 2. Check reverse sensing pole. Check TR-109 (2SC968).
Does not rewind.	Rewind operation SW-15 defective. Supply Reel Motor defective. Check AC Power Voltage. Accumulation of dust particles on tape surface.	Replace Switch. Replace.  Clean tape.
Does not Fast Forward.	Fast Forward operation SW-15 defective. Take-up reel motor defective. Accumulation of dust particles on tape surface.	Replace Switch. Replace. Clean tape.
Magnetic brake operation faulty.	Brake solenoid does not work.  Brake solenoid works.	Solenoid coil defective—Replace. Check F.Fwd Rwd. Relay. Diode 10D4 (D3) short—Replace. Adjustment or brake lever spring faulty—Re-adjust. SW-8 (Micro Switch) defective—Replace.
Tape slack at beginning of play mode.  Wow/Flutter.	Tension arm spring has come loose. No grease on tension arm shaft.  Check to see whether brake shoe is touching reel table. Check pinch roller pressure. Excessive wow during normal play. Excessive wow during reverse operation. Excessive torque motor vibration. Main motor revolutions faulty.	Repair. Grease shaft (HIVAC G is recommended).  Adjust brake.  Pressure should be 2 kg ±100 gr. Adjust back tension (R <sub>2</sub> 330 Ω 30 W). Adjust tape tension (R <sub>1</sub> 120 Ω, R <sub>2</sub> 330 Ω). Replace motor. See main motor and servo-circuit trouble shooting.

## SECTION B TROUBLE WITH MAIN (SERVO) MOTOR

Symptom	Remarks	
Incorrect motor revolutions.	<p>Possible to adjust speed (see adjustment methods).</p> <p>Impossible to adjust speed.</p> <p>Check output of detector head (output of both terminals).</p> <p>Correct Values :</p> <p>60 mV p-p at 7-1/2 ips</p> <p>30 mV p-p at 3-3/4 ips</p> <p>15 mV p-p at 1-7/8 ips</p> <p>Motor Coil defective.</p> <p>Motor Condenser defective.</p> <p>B+ (24 V) voltage supply.</p> <p>No B+ Voltage supply.</p>	<p>Adjust speed.</p> <p>In case head output is low (speed high), rotor gap is too wide—Adjust.</p> <p>In case of no output at all (speed high), head is defective—Replace.</p> <p>Replace.</p> <p>Replace.</p> <p>Check TR-206, 207, 208, and 209.</p> <p>Servo print board—Replace.</p> <p>Check DC supply circuit.</p>

## SECTION C TROUBLE WITH AMPLIFIER R

### 1. Play Mode Playback Pre-Amp Car KD-5023

Symptom	Remarks	
No sound from Line Out Jack.	<p>No B+ Voltage Supply.</p> <p>B+ Voltage Supply.</p>	<p>Diode D-252, TR-252, TR-252, TR-253 on KD-5023 Play Card defective—Replace.</p> <p>Check VR-252 (1 KB).</p> <p>Check working order of Transistors TR-101 and TR-102 and IC-101.</p> <p>Check working order of circuit (see voltage written in schematic).</p>
Will play, but volume insufficient.	<p>B+ Voltage low.</p> <p>B+ Voltage normal.</p>	<p>Diode D-252 or Transistor TR-253 defective—Replace.</p> <p>Oxide deposits have accumulated on head—Clean head.</p> <p>Playback Head defective—Replace.</p>
Humming noise.	<p>When Playback Head is grounded noise decreases.</p> <p>Grounding Playback Head does not alter hum.</p>	<p>Playback Head defective—Replace.</p> <p>Power Supply Circuit TR-253, C-251, C-252, or other C.R. defective Replace.</p>
Sound distorted.	<p>Oxide has accumulated on Playback Head.</p> <p>Check to see if B+ Voltage is normal.</p> <p>Check Bias Voltage.</p>	<p>Clean Head.</p> <p>In case B+ Voltage is low, check Power Supply Circuit.</p> <p>In case B+ Voltage is normal, check voltage of pre-amplifier parts.</p> <p>In case Bias Voltage is incorrect, readjust bias by turning TC-301, 302 (50 p to 70 p).</p>
Hissing noise.	<p>TR-101, TR-102, C-101, IC-101 Defective.</p> <p>Head magnetized.</p> <p>Defective playback head coil.</p>	<p>Replace.</p> <p>Demagnetize head.</p> <p>Replace.</p>

Symptom	Remarks	
Recording Level Low.	Dirty Head. Faulty adjustment of recording and playback level. Tape itself defective.	Clean Head. Follow adjustment procedure.
Sound drop out.	VU Meter indication and monitoring sound normal. VU Meter fails and monitoring sound not normal.	Head worn out—Replace head. Tape old or defective. Poor contact component connections.
Irregular Scratching or Crackling noise.	Transistor TR-101, TR-102, IC-101 defective. Resistor R-102, R-105, C-101 defective.	Replace. Replace.
Squeaking noise.	Oxide collected on head surface. Tape itself squeaks.	Clean head. Clean or replace tape.
Lack of Treble.	Oxide collected on Playback Head surface. Discrepancy in Playback Head Azimuth Alignment. Head worn out.	Clean head. Re-adjust. Replace head.

## 2. RECORDING MODE

Symptom	Remarks	
Does not record.	No VU Meter indication.  VU Meter indicates properly.  Check to see whether OSC circuit is operating (check Bias supply).	Recording input signal level is too low. Check working order of TR-201, 202, 203, and 204 on Rec. Amp Card (KD-5024). Oxide collected on surface of recording head—Clean head. Transistor TR-205 defective—Replace. Check working order of TR-205. Check Relay RL-301 (on OSC Card KD-5025). If not operating, check TR-301, 302, L-301. Check TR-107, TR-108.
Sound distorted.	VU Meter operating properly and recording monitor sound also normal.  VU Meter operating properly, but monitor sound distorted.	Check bias voltage and bias oscillator circuits. Clean head. TR-205 defective—Replace. Recording input signal level excessive. Recording input signal distorted.

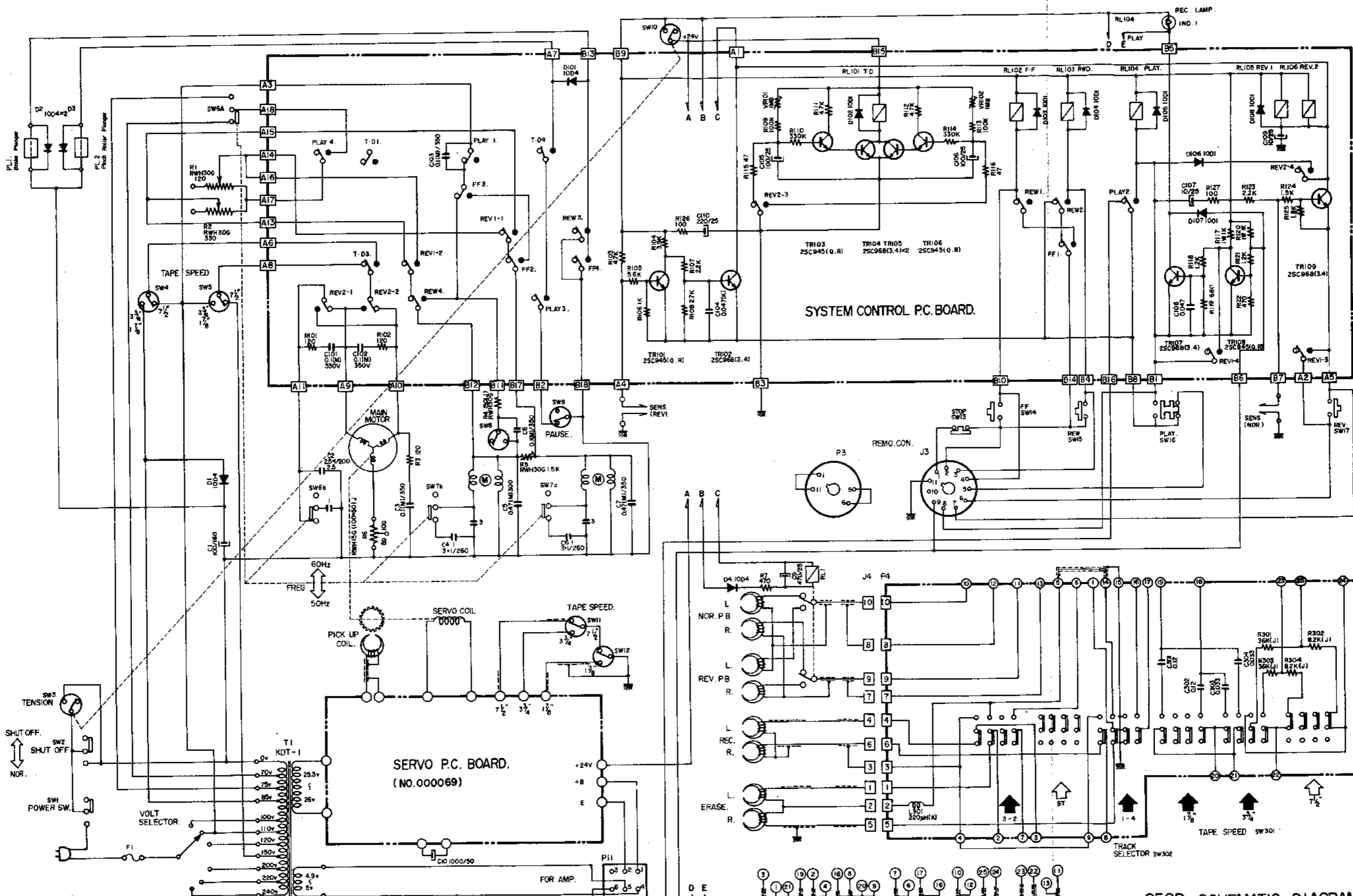

NOTE  
 UNLESS OTHERWISE SPECIFIED  
 ALL RESISTORS IN OHMS (1/4W/1K)  
 ALL CAPACITORS IN MFD (1/50WV, MFD/WV,  
 J1 --- A1 --- A18  
 J2 --- B1 --- B18

250D SCHEMATIC DIAGRAM  
 (MECHA. BLOCK DIAGRAM.)  
 No. 2-1 14020380

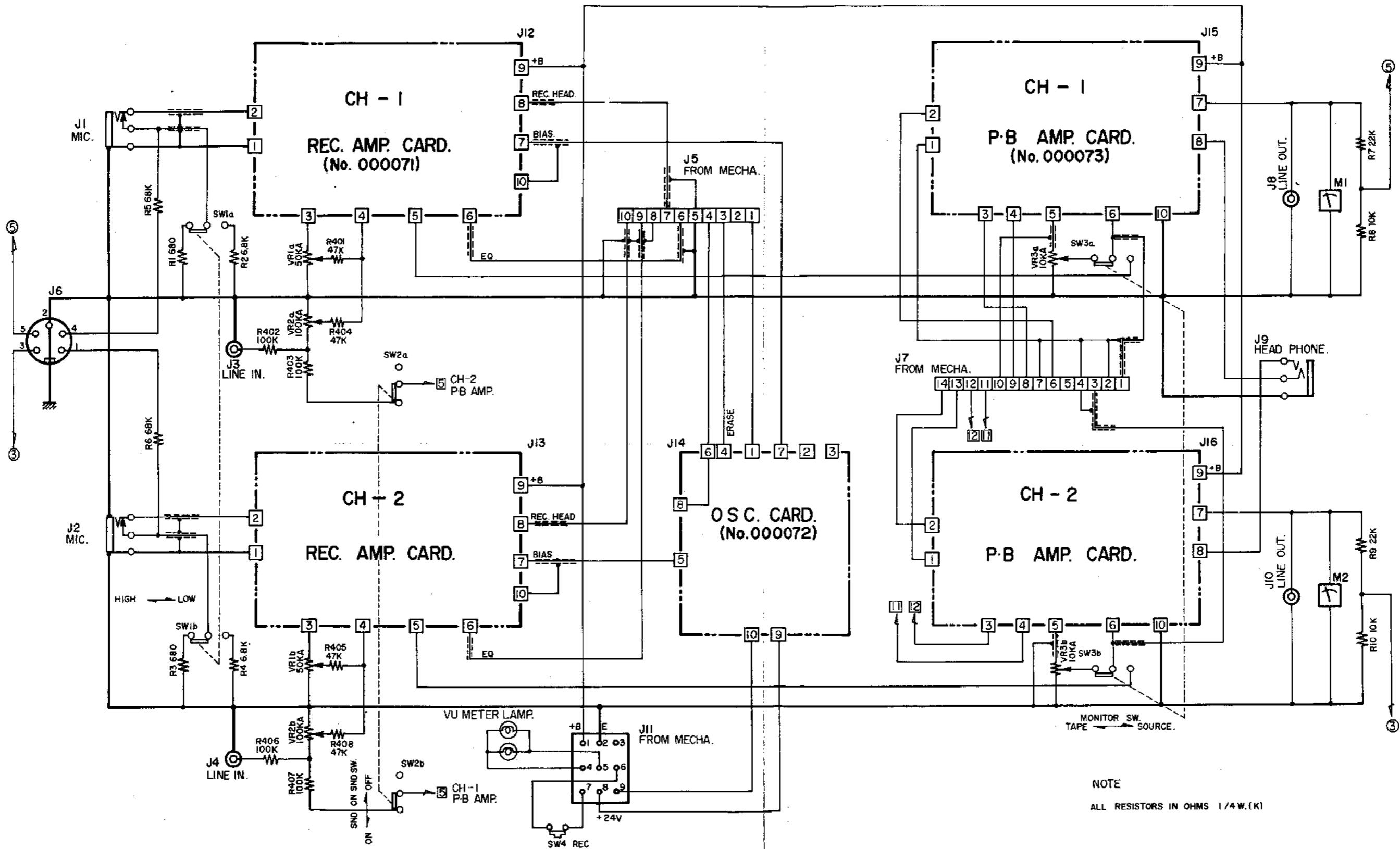

NOTE  
ALL RESISTORS IN OHMS 1/4W.(K)

250D SCHEMATIC DIAGRAM  
No. 2-2 (AMP. BLOCK DIAGRAM.) 14020400

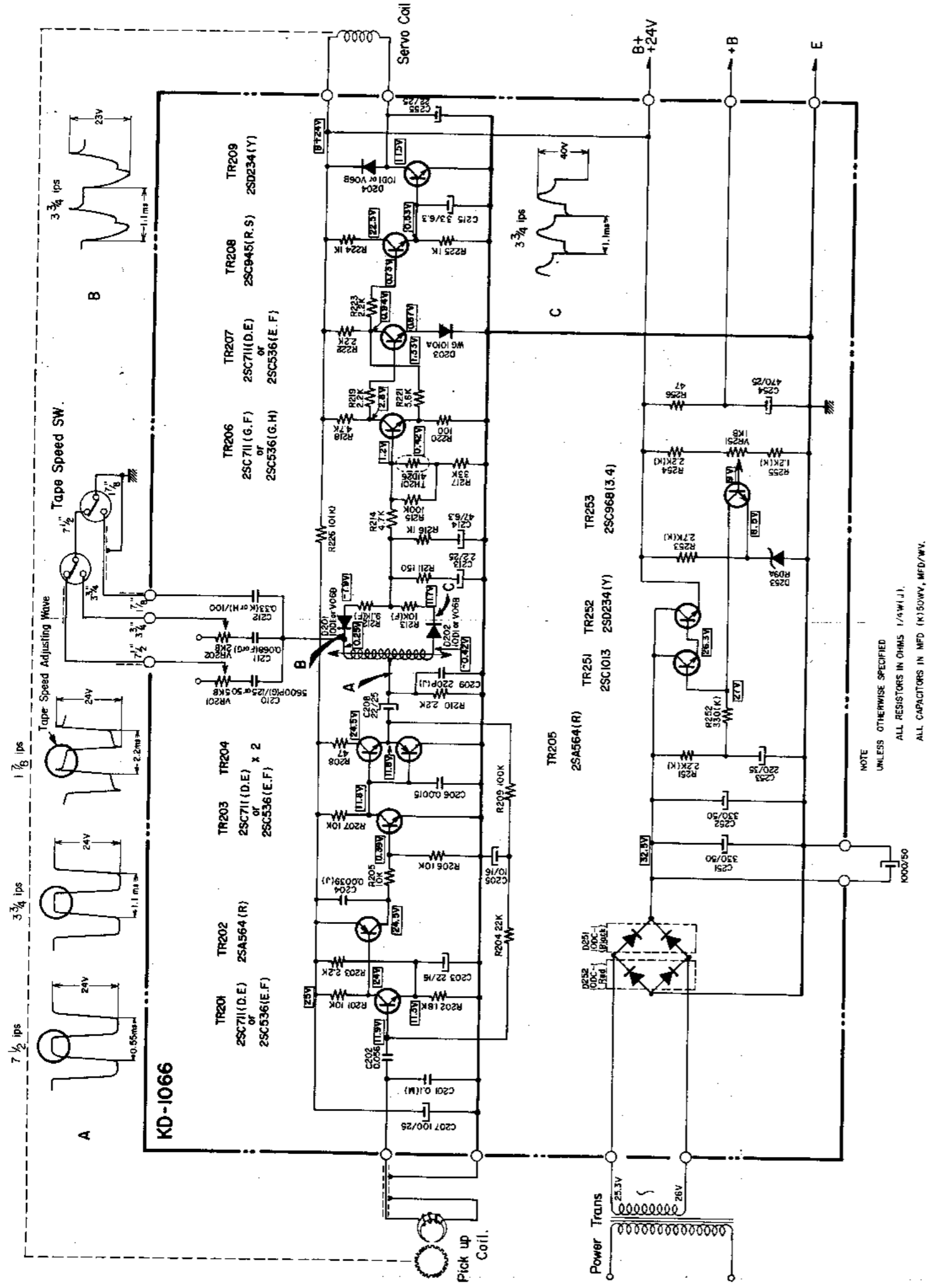

250D SERVO. SCHEMATIC DIAGRAM, No.4 - 1

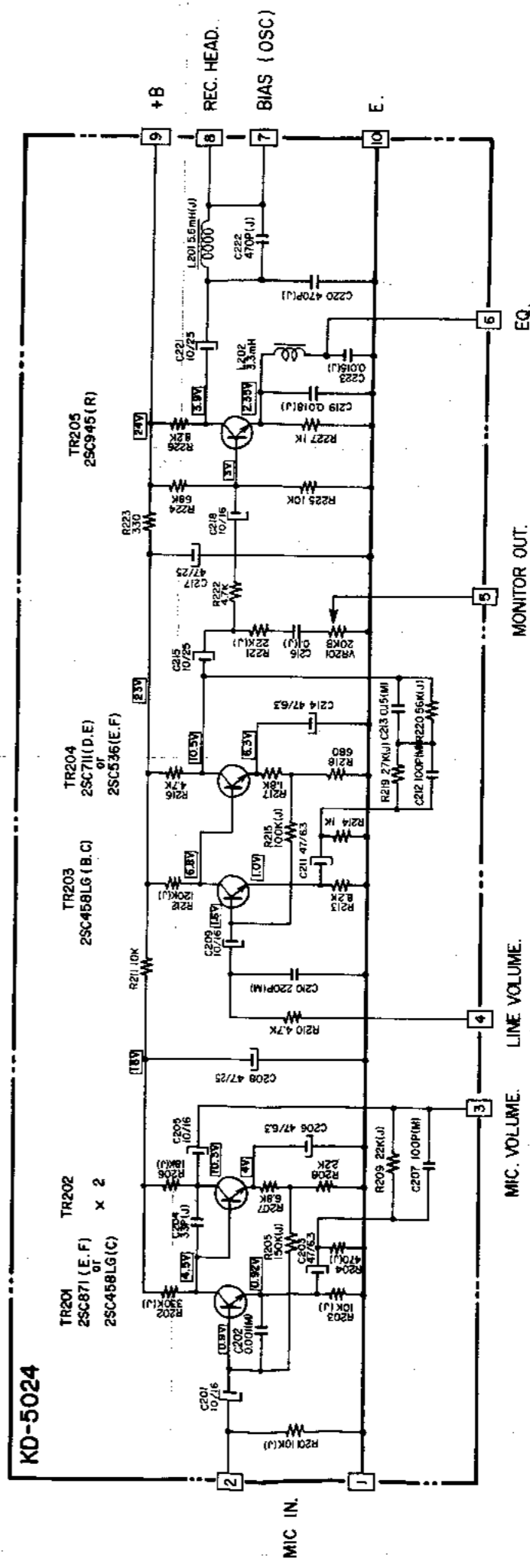

250D REC. AMP. SCHEMATIC DIAGRAM No.4 - 2



**KD-5025**

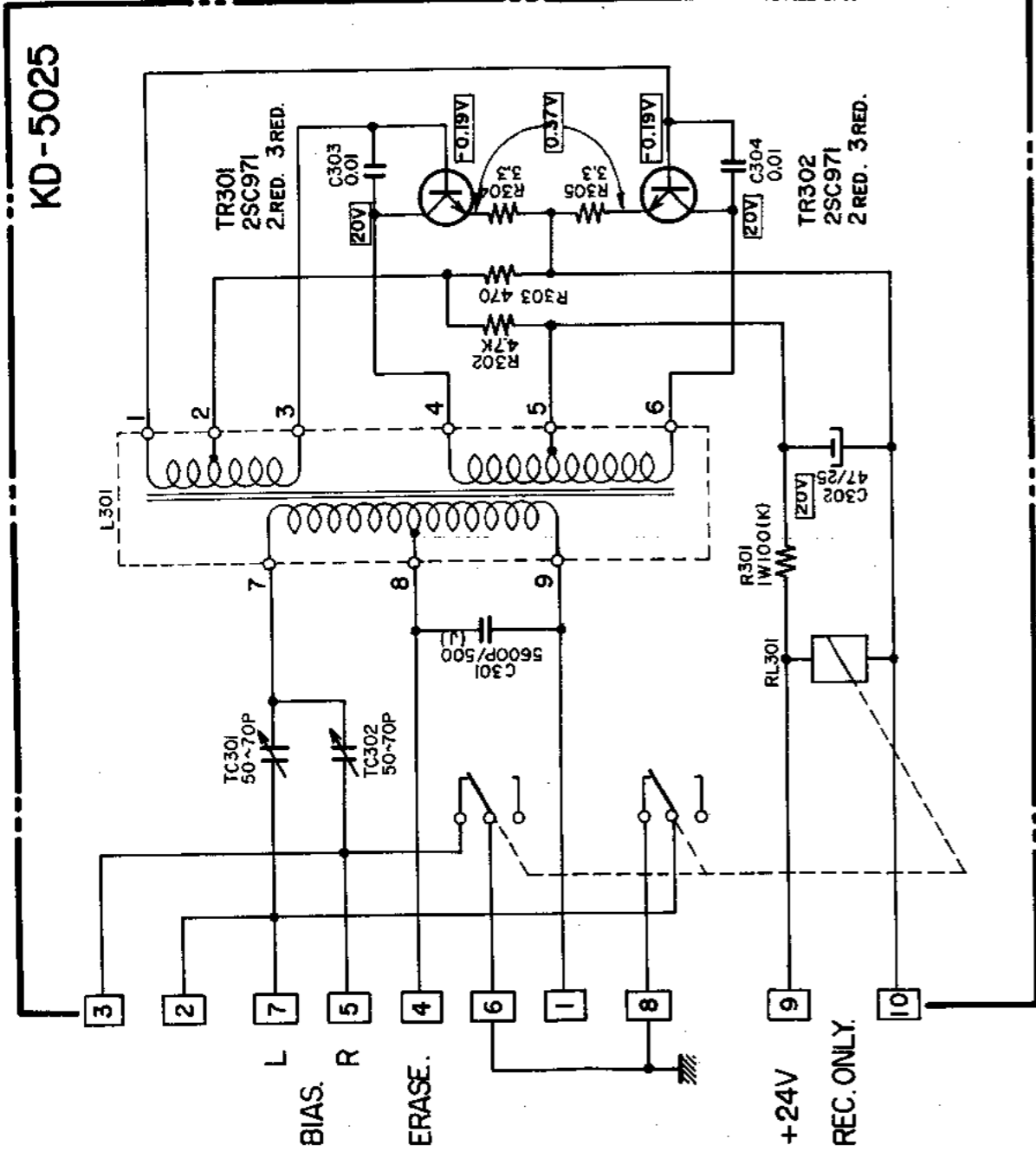

NOTE.  
UNLESS OTHERWISE SPECIFIED.

ALL RESISTORS IN OHMS (J) 1/4W(J)

ALL CAPACITORS IN MFD (J) 50WV, MFD/WV.

**250D OSC. SCHEMATIC DIAGRAM No.4 - 3**

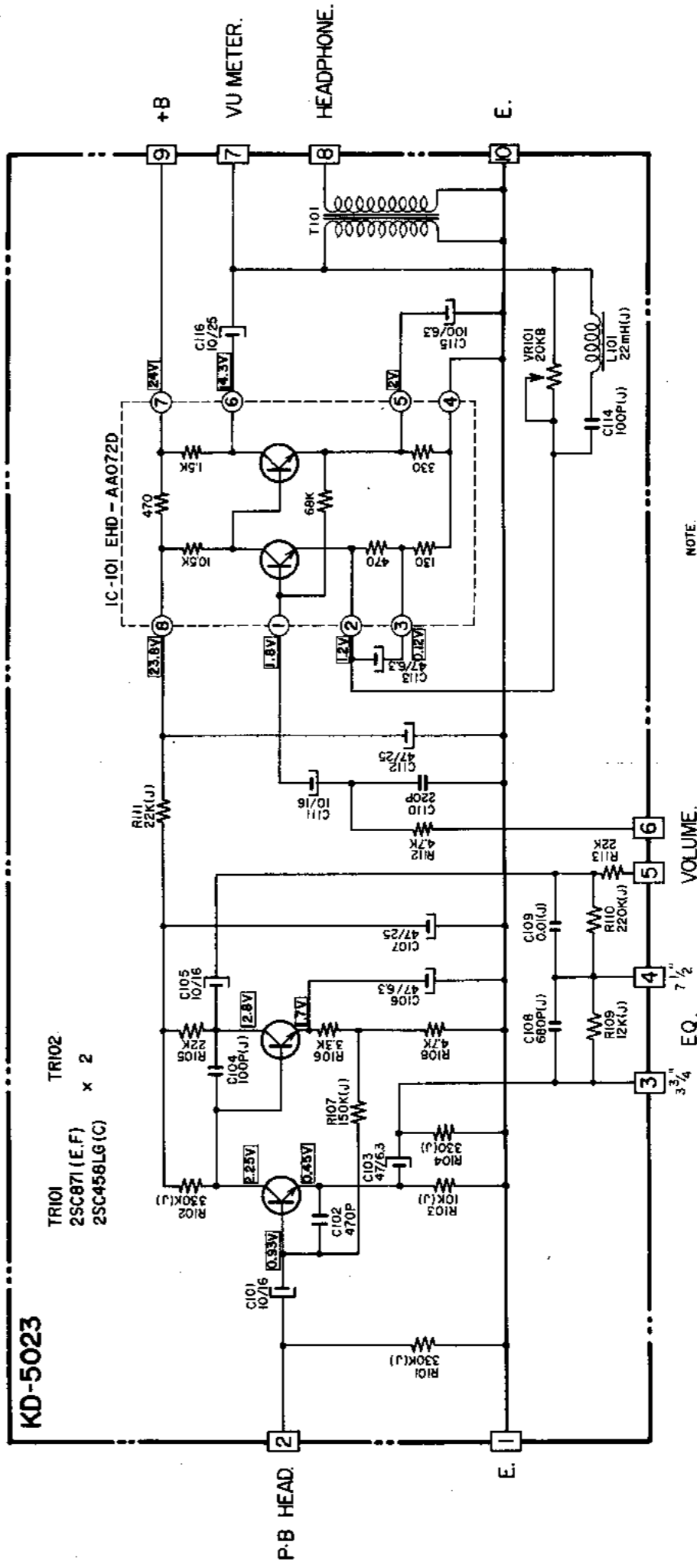

NOTE.  
UNLESS OTHERWISE SPECIFIED.

ALL RESISTORS IN OHMS 1/4W (K).

ALL CAPACITORS IN MFD. (K) 50WV, MFD/WV.

**SYSTEM CONTROL P.C. BOARD (KD-1073A, B)**

For easy repair, patterns of both Sides of this P.C. Board are shown in the Service Manual.  
By placing the transparent sheet on which (KD-1073A) is shown over pattern (KD-1073B),  
both sides can be seen at same time.

